



DEPARTMENT OF HEALTH CARE ACCESS AND INFORMATION
FACILITIES DEVELOPMENT DIVISION

APPLICATION FOR HCAI PREAPPROVAL OF
MANUFACTURER'S CERTIFICATION (OPM)

OFFICE USE ONLY

APPLICATION #: OPM-0050

HCAI Preapproval of Manufacturer's Certification (OPM)

Type: New Renewal/Update

Manufacturer Information

Manufacturer: Cenorin

Manufacturer's Technical Representative: Jenette Bennett

Mailing Address: 6324 S. 199th Place, Suite 107, Kent, WA 98032

Telephone: (800) 426-1042

Email: jbennett@cenorin.com

Product Information

Product Name: Thermasure Dryers

Product Type: Other mechanical or electrical components

Product Model Number: 130, 340 and 1000

General Description: Floor Mounted Drying Systems

Applicant Information

Applicant Company Name: EASE LLC.

Contact Person: Tiffany Tonn

Mailing Address: 1515 FAIRVIEW AVE, STE 205, MISSOULA, MT 59801

Telephone: (406) 541-3273

Email: tiffany@easeco.com

Title: Office Manager

"Access to Safe, Quality Healthcare Environments that Meet California's Diverse and Dynamic Needs"

STATE OF CALIFORNIA – HEALTH AND HUMAN SERVICES AGENCY





**DEPARTMENT OF HEALTH CARE ACCESS AND INFORMATION
FACILITIES DEVELOPMENT DIVISION**

Registered Design Professional Preparing Engineering Recommendations

Company Name: EASE

Name: Jonathan Roberson

California License Number: S4197

Mailing Address: 5877 Pine Ave., Suite 210, Chino Hills, CA 91709

Telephone: (951) 295-1892

Email: jon@EASECo.com

HCAI Special Seismic Certification Preapproval (OSP)

Special Seismic Certification is preapproved under OSP

OSP Number: _____

Certification Method

Testing in accordance with: ICC-ES AC156 FM 1950-16

Other(s) (Please Specify): _____

*Use of criteria other than those adopted by the California Building Standards Code, 2019 (CBSC 2019) for component supports and attachments are not permitted. For distribution system, interior partition wall, and suspended ceiling seismic bracings, test criteria other than those adopted in the CBSC 2019 may be used when approved by HCAI prior to testing.

Analysis

Experience Data

Combination of Testing, Analysis, and/or Experience Data (Please Specify): _____

HCAI Approval

Date: 4/27/2022

Name: Mohammad Aliaari

Title: Senior Structural Engineer

Condition of Approval (if applicable): _____

"Access to Safe, Quality Healthcare Environments that Meet California's Diverse and Dynamic Needs"

STATE OF CALIFORNIA – HEALTH AND HUMAN SERVICES AGENCY





**EQUIPMENT ANCHORAGE
& SEISMIC ENGINEERING**

5877 Pine Ave, Ste. 210
Chino Hills, CA. 91709
Phn: (909) 606-7622

The Department of Health Care Access and Information
PREAPPROVAL OF MANUFACTURER'S CERTIFICATION
OPM-0050

THIS PREAPPROVAL CONFORMS TO THE 2019 CALIFORNIA BUILDING CODE

MANUFACTURER: **CENORIN**
EQUIPMENT NAME: **THERMASURE 130, 300 AND 1000 SERIES DRYERS**

Sheet: 1 of 8
Date: 4/25/22

GENERAL NOTES

1. THIS HCAI PREAPPROVAL OF MANUFACTURER'S CERTIFICATION (OPM) IS BASED ON THE 2019 CBC. THE DEMANDS (DESIGN FORCES) FOR USE WITH THIS OPM SHALL BE BASED ON THE 2019 CBC
2. THIS DOCUMENT MAY ONLY BE USED WITH THE EXPRESS WRITTEN CONSENT OF THE MANUFACTURER LISTED ABOVE FOR THE SPECIFIC PROJECT SITE AND INSTALLATION LOCATION. THIS DOCUMENT IS INVALID WITHOUT SUCH CONSENT.
3. THIS PREAPPROVAL CONFORMS TO THE 2019 CALIFORNIA BUILDING CODE WHERE S_{ds} IS NOT GREATER THAN 2.00 & 2.10. SEE DETAIL FOR APPLICABILITY
4. FORCES PER ASCE 7-16 SECTION 13.3.1, EQUATIONS 13.3-1, 13.3-2 & 13.3-3,
WHERE $S_{ds} = 2.10$, $a_p = 1.0$, $I_p = 1.5$, $R_p = 1.5$, $z/h = 0$ AT CONCRETE SLAB. SEE FOLLOWING SHEETS FOR Ω_0 .
WHERE $S_{ds} = 2.00$, $a_p = 1.0$, $I_p = 1.5$, $R_p = 1.5$, $z/h \leq 1$ AT CONCRETE SLAB ON METAL DECK. SEE FOLLOWING SHEETS FOR Ω_0 .
5. THIS PREAPPROVAL COVERS ONLY THE SUPPORTS AND ATTACHMENTS OF THE EQUIPMENT TO THE STRUCTURE.
6. ALL DESIGN FORCES SHOWN ON THE DRAWINGS ARE FACTORED LOADS THAT SHALL BE USED FOR STRENGTH DESIGN.
7. CONCRETE SLAB ON METAL DECK DETAIL VALID FOR DEMANDS SHOWN AT ANY ELEVATION IN THE BUILDING. (i.e. $z/h \leq 1$)
8. CONCRETE SLAB DETAIL VALID FOR DEMANDS SHOWN AT OR BELOW GRADE. (i.e. $z/h = 0$)

9. RESPONSIBILITIES OF THE STRUCTURAL ENGINEER OF RECORD OF THE BUILDING

- A. PROVIDE SUPPORTING STRUCTURE TO SUPPORT WEIGHTS AND FORCES SHOWN IN ADDITION TO ALL OTHER LOADS.
- B. VERIFY THAT THE INSTALLATION IS IN CONFORMANCE WITH THE 2019 CBC AND WITH THE DETAILS, MATERIAL AND GAGE OF THE UNIT WHERE ATTACHMENTS ARE MADE AGREE WITH THE INFORMATION SHOWN ON THE PREAPPROVAL DOCUMENTS.
- C. VERIFY THAT PROJECT SPECIFIC VALUES OF S_{ds} & z/h RESULT IN SEISMIC FORCES (E_h , E_v) THAT DO NOT EXCEED THE VALUES ON THE DETAILS.
- D. VERIFY THAT THE CONCRETE SLAB TO WHICH THE EQUIPMENT IS ANCHORED MEETS THE REQUIREMENTS OF THE APPLICABLE ICC ESR REPORT AND THIS OPM.
- E. VERIFY THAT THE ANCHORS ARE AN ADEQUATE DISTANCE FROM ANY SLAB EDGES OR OPENINGS (SEE TYPICAL DETAIL ON SHEET 2).
- F. VERIFY THAT ALL NEW OR EXISTING ANCHORS ARE AN ADEQUATE DISTANCE FROM THE UNIT ATTACHMENTS AND CHECK FOR INTERACTION WHERE OTHER ANCHORS ARE WITHIN 18" OR $6h_{ef}$ FROM THIS UNIT'S ANCHORS.



CENORIN

DES. **J. ROBERSON**

SHEET

2

JOB NO. **11-2201**

DATE **4/25/22**

OF **8** SHEETS

THERMASURE 130, 300 AND 1000 SERIES DRYERS

10. EXPANSION ANCHORS:

- A. ATTACHMENT IS TO BE MADE WITH THE ANCHORS LISTED BELOW AND INSTALLED AS DESCRIBED IN THE CORRESPONDING ICC REPORT.

Anchor Diameter	Concrete Type	Min. f'c (psi)	Anchor Type	ICC Report No.	Min. Embed.	Min. Spacing	Min. Edge Dist.	Min. Conc. Thickness	Torque Test	Direct Tension Test
1/2"	Sand Light Weight	3000	Hilti Kwik Bolt TZ2 (CARBON STEEL)	ESR-4266	3.25"	6.75"	12"	See Detail "A"	50 FT-LB	N/A
5/8"	Normal Weight	3000	Hilti Kwik Bolt TZ2 (CARBON STEEL)	ESR-4266	4"	12"	26"	6"	40 FT-LB	4540 lb

- B. THIS PREAPPROVAL ALLOWS FOR UP TO A MAXIMUM OF 2 ADJACENT CONCRETE SLAB EDGES, 26" AWAY MINIMUM (i.e. - CORNER). SEE ADJACENT DETAIL FOR ADDITIONAL MINIMUM ALLOWABLE CONCRETE EDGE DISTANCES.

- C. TESTING AND SPECIAL INSPECTION OF EXPANSION ANCHORS SHALL BE PERFORMED BY AN APPROVED INDEPENDENT AGENCY EMPLOYED BY THE FACILITY OWNER PER CBC 1704A & 1910A.5 AND CAC 7-149. ALL REPORTS SHALL BE SENT TO THE INSPECTOR OF RECORD, OWNER AND THE ARCHITECT OR ENGINEER IN RESPONSIBLE CHARGE.

- (i) AFTER AT LEAST 24 HOURS HAVE ELAPSED SINCE INSTALLATION, DIRECT PULL TENSION TEST OR TORQUE TEST AT LEAST 50% OF THE ANCHORS.

- (ii) ACCEPTANCE CRITERIA:

- DIRECT TENSION TEST: THE ANCHOR SHOULD HAVE NO OBSERVABLE MOVEMENT AT THE TEST LOAD. A PRACTICAL WAY TO DETERMINE OBSERVABLE MOVEMENT IS THAT THE WASHER BECOMES LOOSE.
- TORQUE TEST: THE APPLICABLE TORQUE MUST BE ACHIEVED WITHIN THE FOLLOWING LIMITS: WEDGE TYPE : 1/2 TURN OF THE NUT

- (iii) IF ANY ANCHOR FAILS, TEST ALL ANCHORS.

- D. AVOID DAMAGING EXISTING STEEL REINFORCING IN CONCRETE SLAB WHEN INSTALLING CONCRETE EXPANSION ANCHORS.

- E. PROVIDE FOR FULL THREAD ENGAGEMENT OF NUT & WASHER.

11. BOLTS THROUGH CONCRETE ON METAL DECK

- A. BOLTS SHALL BE TORQUED BY 3/4 TURN OF THE NUTS AFTER THE SNUG TIGHT (THE SNUG-TIGHT CONDITION IS DEFINED AS THE TIGHTNESS REQUIRED TO BRING THE CONNECTED PLIES INTO FIRM CONTACT) CONDITION IS ACHIEVED, UNLESS OTHERWISE NOTED.
- B. THROUGH BOLT HOLES SHALL BE 1/16" LARGER THAN BOLT SIZE (HOLE SIZE = BOLT SIZE + 1/16") FOR CONCRETE.
- C. THROUGH-BOLTS IN CONCRETE SHALL RECEIVE SPECIAL INSPECTION AND TESTING (THROUGH BOLTS WITH STEEL TO STEEL CONNECTION IN TENSION DO NOT REQUIRE TENSION TESTING) IN ACCORDANCE WITH REQUIREMENTS FOR POST-INSTALLED ANCHORS.

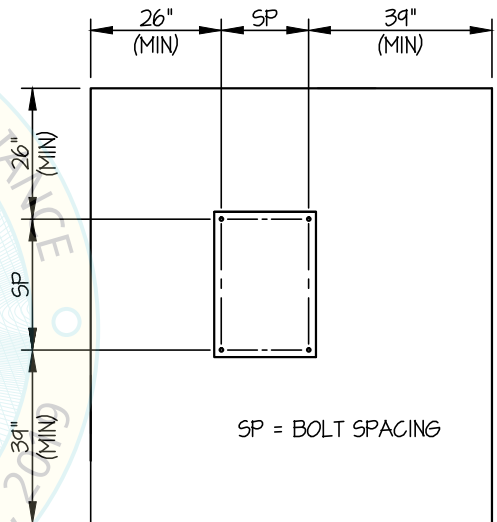

TYPICAL CONCRETE EDGE DETAIL
(SLAB ON GRADE ONLY)



CENORIN

DES. J. ROBERSON

SHEET

3

THERMASURE 130, 300 AND 1000 SERIES DRYERS

JOB NO. 11-2201

DATE 4/25/22

OF 8 SHEETS

SEISMIC SUPPORTS & ATTACHMENTS

CONCRETE SLAB

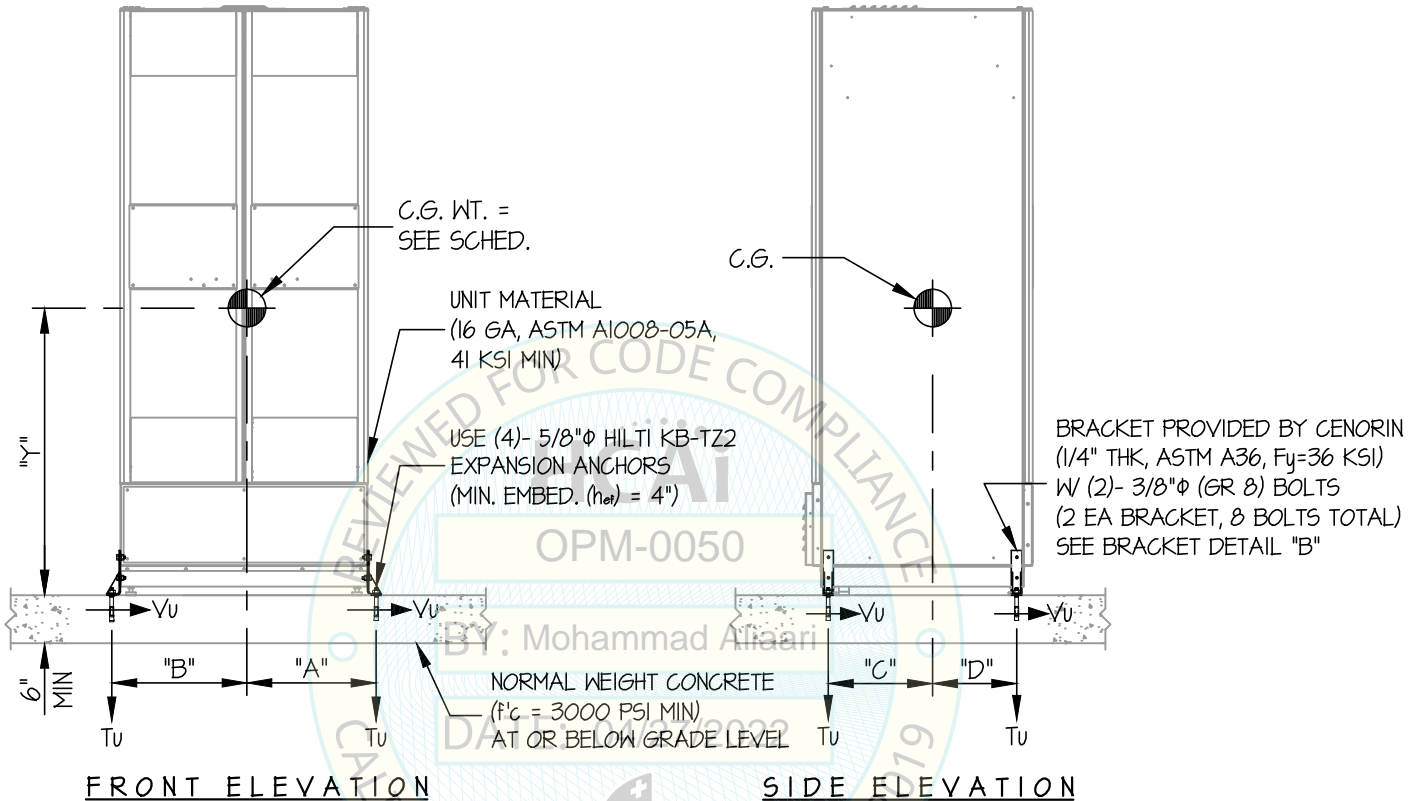

NOTES:

1. FORCES ARE DETERMINED PER 2019 CALIFORNIA BUILDING CODE AND ASCE 7-16 STRENGTH DESIGN IS USED. ($S_{ds} = 2.10$, $a_p = 1.0$, $I_p = 1.5$, $R_p = 1.5$, $\Omega_o = 2.0$, $z/h = 0$)

HORIZONTAL FORCE (E_h) = $0.945 W_p$

HORIZONTAL FORCE (E_{mh}) = $1.89 W_p$ (FOR CONCRETE ANCHORAGE)

VERTICAL FORCE (E_v) = $0.42 W_p$

2. CENTER OF GRAVITY (C.G.) AND WEIGHT ARE THE GOVERNING PARAMETERS FOR DESIGN. THESE CALCULATIONS ENCOMPASS ALL WEIGHTS UP TO THE MAXIMUM WEIGHT SHOWN.

3. STRUCTURAL ENGINEER OF RECORD FOR THE BUILDING SHALL VERIFY ALL CONDITIONS AND PROVIDE SUPPORT STRUCTURE DESIGNED TO SUPPORT WEIGHTS AND FORCES SHOWN IN COMBINATION WITH ALL OTHER LOADS THAT MAY BE PRESENT.

4. SEE GENERAL NOTES: SHEETS 1 AND 2.

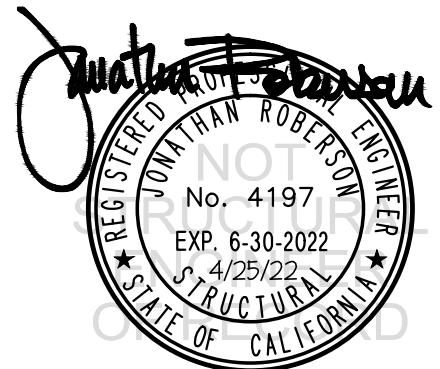

CENORIN

DES. J. ROBERSON

SHEET

4

THERMASURE 130, 300 AND 1000 SERIES DRYERS

JOB NO. 11-2201

DATE 4/25/22

OF 8 SHEETS

SEISMIC SUPPORTS & ATTACHMENTS

CONCRETE SLAB

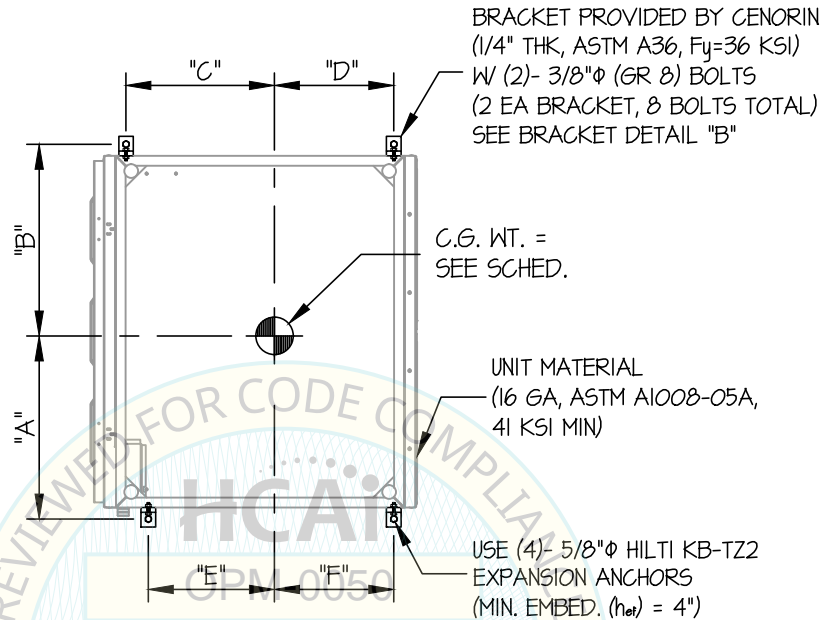

PLAN VIEW

SERIES NUMBER	WEIGHT MAX (lb.)	"Y" MAX (in.)	"A" MIN (in.)	"B" MIN (in.)	"C" MIN (in.)	"D" MIN (in.)	"E" MIN (in.)	"F" MIN (in.)	+ T _u (lb.)	+ V _u (lb.)
130	1160	40	13.6	14.8	11.0	11.0	11.0	11.0	2395	1471
300	1240	43	18.7	19.7	11.0	9.8	11.0	9.8	2740	1600
1000	1249	42	18.3	20.1	15.5	11.8	13.2	11.8	2319	1617

+ VALUES INCLUDE Ω



CENORIN

THERMASURE 130, 300 AND 1000 SERIES DRYERS

DES. J. ROBERSON

JOB NO. 11-2201

DATE 4/25/22

SHEET

5

OF 8 SHEETS

SEISMIC SUPPORTS & ATTACHMENTS

CONCRETE SLAB ON METAL DECK

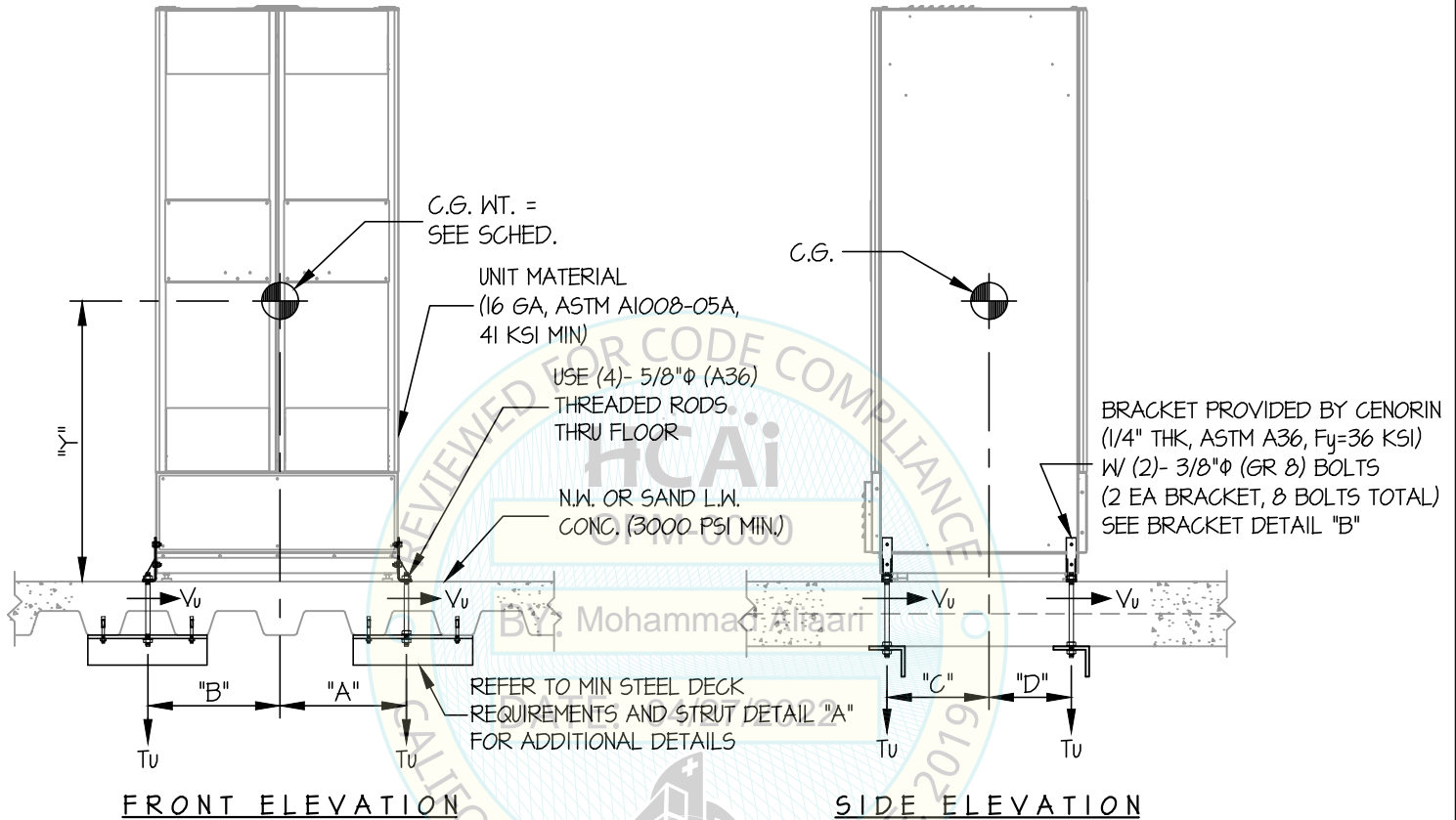

NOTES:

1. FORCES ARE DETERMINED PER 2019 CALIFORNIA BUILDING CODE AND ASCE 7-16.

STRENGTH DESIGN IS USED. ($S_{ds} = 2.00$, $\alpha_p = 1.0$, $I_p = 1.5$, $R_p = 1.5$, $\Omega_o = 2.0$, $z/h \leq 1$)

HORIZONTAL FORCE (E_h) = $2.40 W_p$

HORIZONTAL FORCE (E_{mh}) = $4.80 W_p$ (FOR CONCRETE ANCHORAGE)

VERTICAL FORCE (E_v) = $0.40 W_p$

2. CENTER OF GRAVITY (C.G.) AND WEIGHT ARE THE GOVERNING PARAMETERS FOR DESIGN. THESE CALCULATIONS ENCOMPASS ALL WEIGHTS UP TO THE MAXIMUM WEIGHT SHOWN.

3. STRUCTURAL ENGINEER OF RECORD FOR THE BUILDING SHALL VERIFY ALL CONDITIONS AND PROVIDE SUPPORT STRUCTURE DESIGNED TO SUPPORT WEIGHTS AND FORCES SHOWN IN COMBINATION WITH ALL OTHER LOADS THAT MAY BE PRESENT.

4. SEE GENERAL NOTES: SHEETS 1 AND 2.



CENORIN

DES. J. ROBERSON

SHEET

6

THERMASURE 130, 300 AND 1000 SERIES DRYERS

JOB NO. 11-2201

DATE 4/25/22

OF 8 SHEETS

SEISMIC SUPPORTS & ATTACHMENTS

CONCRETE SLAB ON METAL DECK

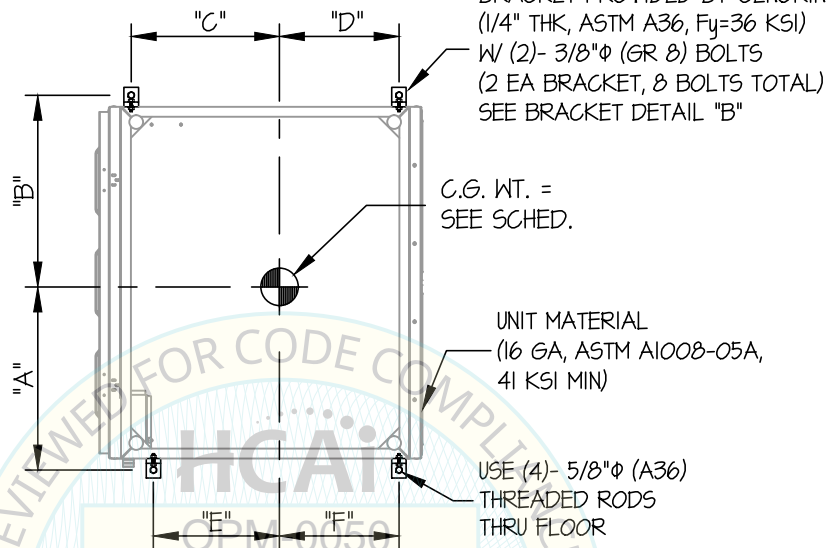

PLAN VIEW

SERIES NUMBER	WEIGHT MAX (lb.)	"Y" MAX (in.)	"A" MIN (in.)	"B" MIN (in.)	"C" MIN (in.)	"D" MIN (in.)	"E" MIN (in.)	"F" MIN (in.)	+ Tu (lb.)	+ Vu (lb.)
130	1160	40	13.6	14.8	11.0	11.0	11.0	11.0	2268	1401
300	1240	43	18.7	19.7	11.0	9.8	11.0	9.8	3517	2032
1000	1249	42	18.3	20.1	15.5	11.8	13.2	11.8	2983	2054

+ VALUES DO NOT INCLUDE Ω .

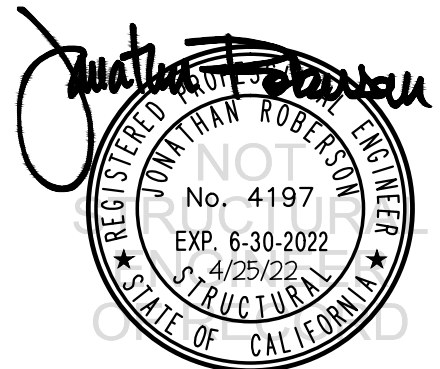

CENORIN

DES. J. ROBERSON

SHEET

7

THERMASURE 130, 300 AND 1000 SERIES DRYERS

JOB NO. 11-2201

DATE 4/25/22

OF 8 SHEETS

SEISMIC SUPPORTS & ATTACHMENTS

CONCRETE DETAIL

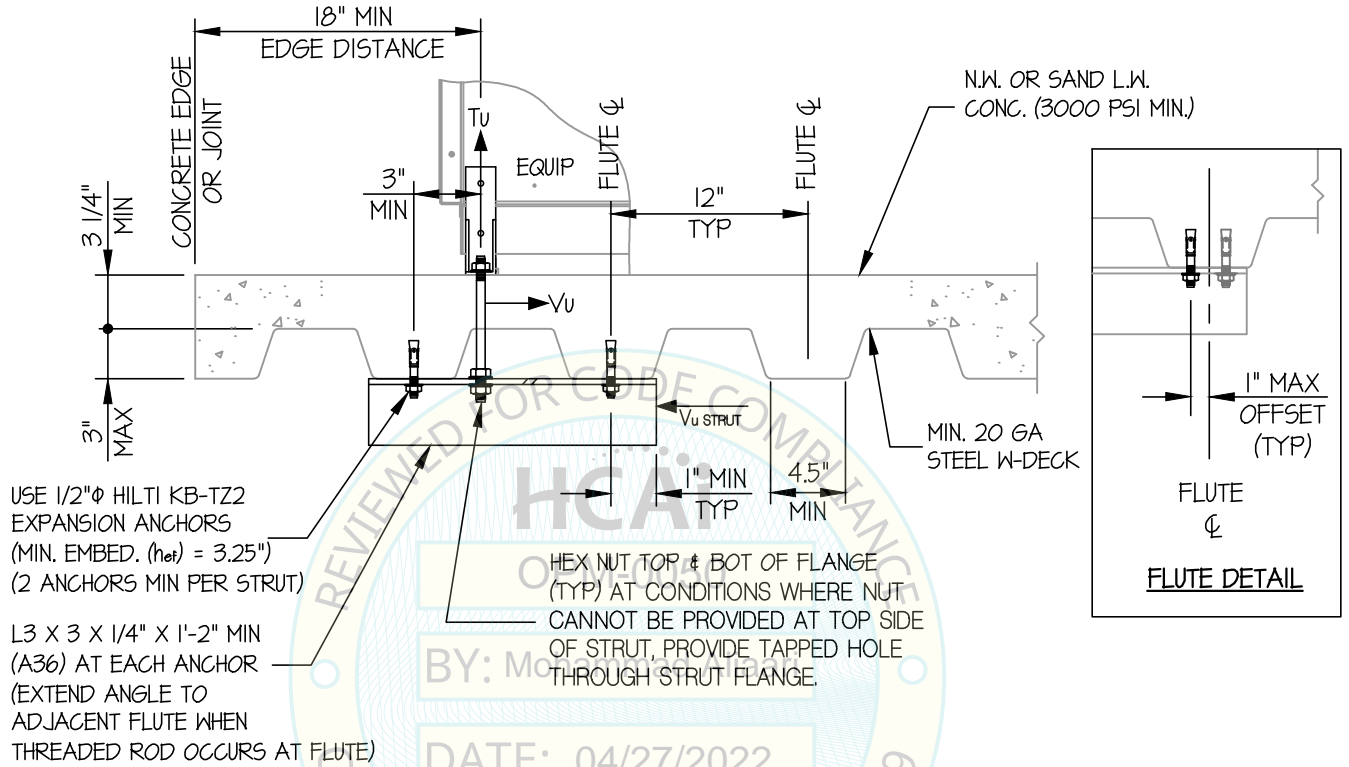

MIN STEEL DECK REQUIREMENTS AND STRUT DETAIL (A)



CENORIN

DES. J. ROBERSON

SHEET

8

THERMASURE 130, 300 AND 1000 SERIES DRYERS

JOB NO. 11-2201

DATE 4/25/22

OF 8 SHEETS

SEISMIC SUPPORTS & ATTACHMENTS

BRACKET DETAIL

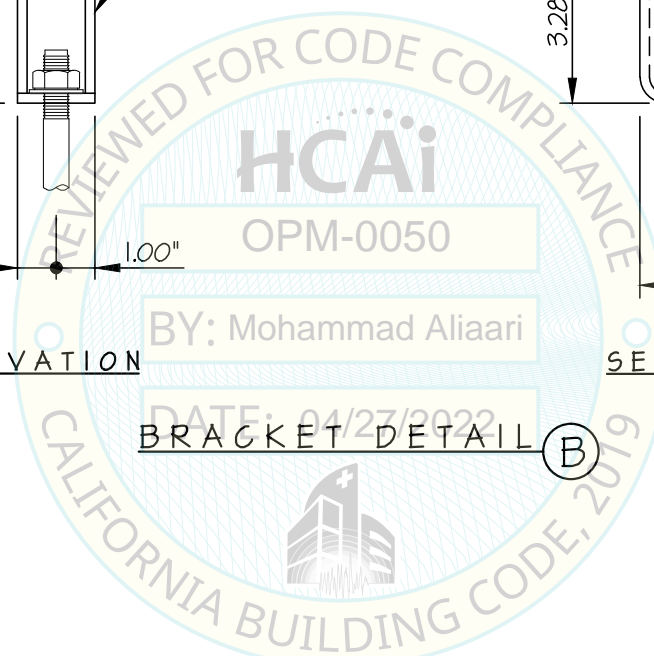
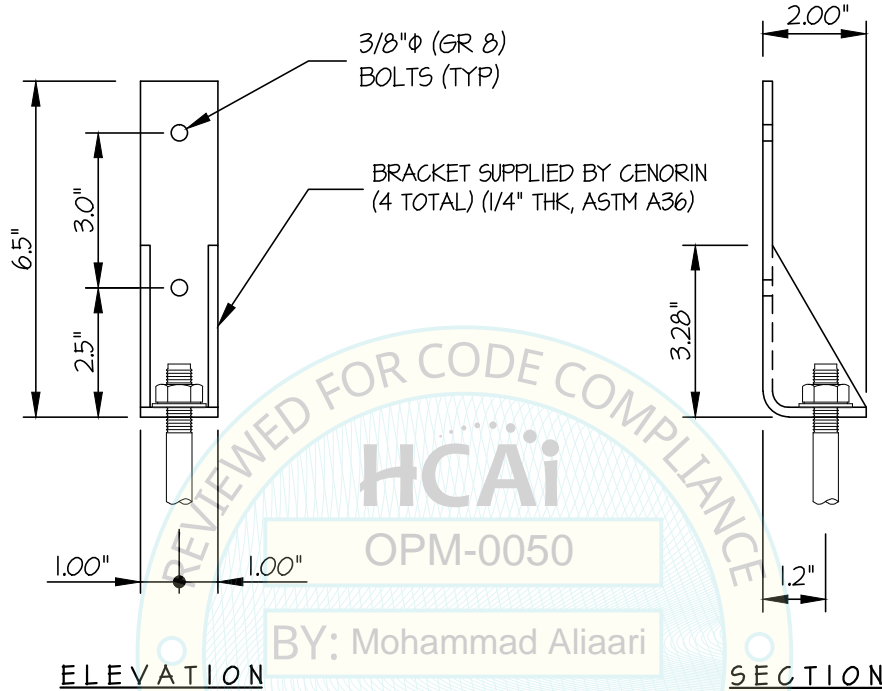

BRACKET DETAIL (B)

