



OFFICE OF STATEWIDE HEALTH PLANNING AND DEVELOPMENT  
ACTIVITIES DEVELOPMENT DIVISION

APPLICATION FOR OSHPD PREAPPROVAL  
OF MANUFACTURER'S CERTIFICATION (OPM)

OFFICE USE ONLY	
APPLICATION #:	OPM-0099-13

OSHPD Preapproval of Manufacturer's Certification (OPM)

Type:  New  Renewal  Update to Pre-CBC 2013 OPA Number: 2531-10

Manufacturer Information

Manufacturer: Hologic

Manufacturer's Technical Representative: Ken DeFreitas, Sr. Staff Mechanical Engineer

Mailing Address: 36 Apple Ridge Road, Danbury, Ct 06810

Telephone: 203-731-8309 Email: ken.defreitas@Hologic.com

Product Information

Product Name: MultiCare

Product Type: \_\_\_\_\_

Product Model Number: \_\_\_\_\_

General Description: Breast Biopsy System

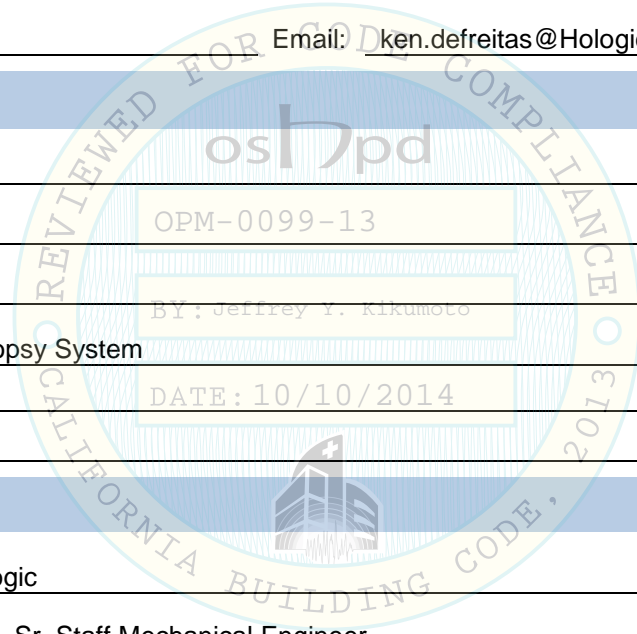

Applicant Information

Applicant Company Name: Hologic

Contact Person: Ken DeFreitas, Sr. Staff Mechanical Engineer

Mailing Address: 36 Apple Ridge Road, Danbury, Ct 06810

Telephone: 203-731-8309 Email: ken.defreitas@Hologic.com

I hereby agree to reimburse the Office of Statewide Health Planning and Development review fees in accordance with the California Administrative Code, 2013.

Signature of Applicant: \_\_\_\_\_ Date: 5-1-14

Title: Sr. Staff Mechanical Engineer Company Name: Hologic

"Access to Safe, Quality Healthcare Environments that Meet California's Diverse and Dynamic Needs"

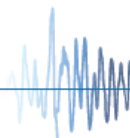



**OFFICE OF STATEWIDE HEALTH PLANNING AND DEVELOPMENT  
ACTIVITIES DEVELOPMENT DIVISION**

**Registered Design Professional Preparing Engineering Recommendations**

Company Name: Don Lee Engineering

Name: Donald E. Lee California License Number: SE 2311

Mailing Address: 21008 Sylvanwood Ave., Lakewood, Ca 90715

Telephone: 562-860-7896 Email: donleese@aol.com

**OSHPD Special Seismic Certification Preapproval (OSP)**

- Special Seismic Certification is preapproved under OSP- (Separate application for OSP is required)
- Special Seismic Certification is not preapproved

**Certification Method(s)**

- Testing in accordance with:  ICC-ES AC156  FM 1950-10
- Other\* (Please Specify): \_\_\_\_\_

\*Use of test criteria other than those adopted by the California Building Standards Code, 2013 (CBSC 2013) for component supports and attachments are not permitted. For distribution system, interior partition wall, and suspended ceiling seismic bracings, test criteria other than those adopted in the CBSC 2013 may be used when approved by OSHPD prior to testing.

- Analysis
- Experience Data
- Combination of Testing, Analysis, and/or Experience Data (Please Specify): \_\_\_\_\_

**List of Attachments Supporting the Manufacturer's Certification**

- Test Report  Drawings  Calculations  Manufacturer's Catalog
- Other(s) (Please Specify): \_\_\_\_\_

**OFFICE USE ONLY – OSHPD APPROVAL VALID FOR CBC 2013 ONLY**

Signature: *Jeffrey Y. Kikumoto* Date: October 10, 2014

Print Name: Jeffrey Y. Kikumoto

Title: Senior Structural Engineer

Condition of Approval (if applicable): \_\_\_\_\_

"Access to Safe, Quality Healthcare Environments that Meet California's Diverse and Dynamic Needs"

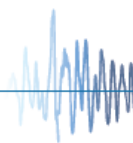

# Don Lee Engineering

21008 Sylvanwood Ave.  
Lakewood, Ca 90715  
562-860-7896

Donald E. Lee Structural Engineer #2311

## OPM-0099-13 Hologic Multi-Care Attachment Forces & Details

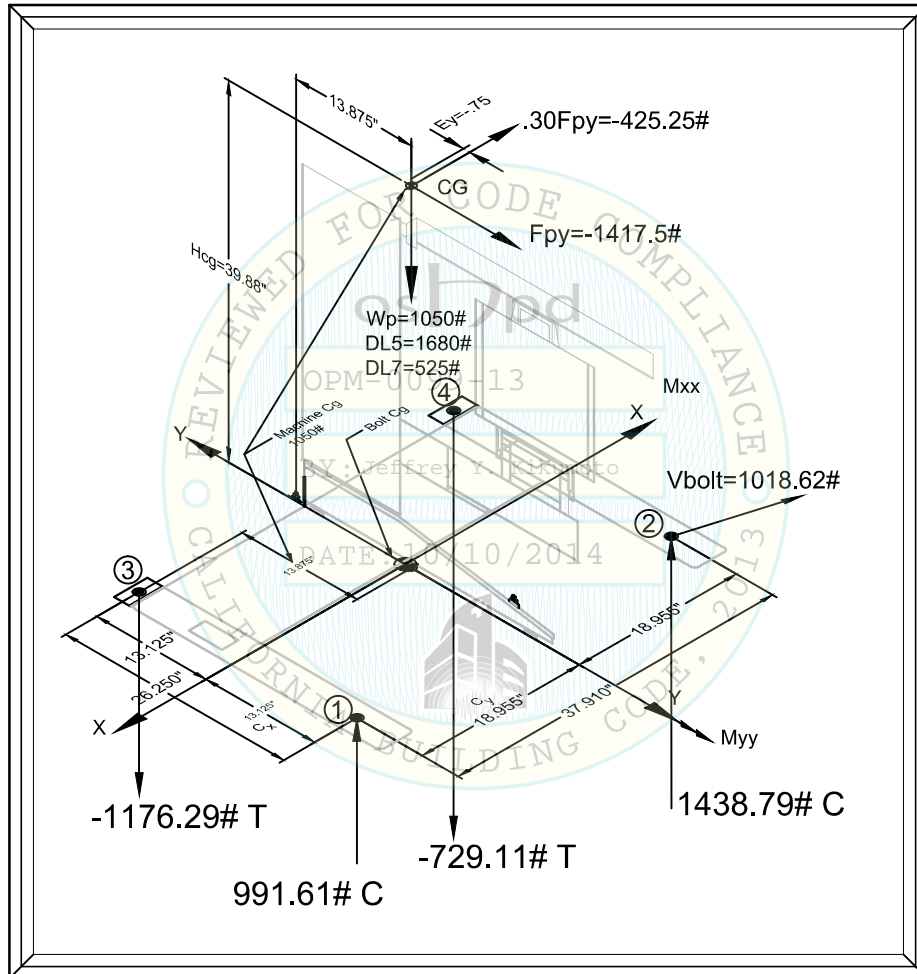

Prepared by  
**Don Lee S. E. #2311**

Signed 10-8-2014



D:\MyFiles\II\AAA DLE Projects\Hologic 2013 OPM Program\Multi-Care\MultiCare OPM-0099-13.dwg, 10/8/2014 12:19:06 PM

D:\MyFiles\FlIAAAA DLE Projects\Hologic 2013 OPM Program\Multi-Care\MultiCare OPM-0099-13.dwg, 10/8/2014 12:26:52 PM

Coordinates			Bolt Pattern Properties	
Location	X	Y	$I_{xx}$	689.26 In <sup>4</sup>
①	0.00"	0.00"	$I_{yy}$	1437.36 In <sup>4</sup>
②	37.91"	0.00"		
③	0.00"	26.25"		
④	37.91"	26.25"		<b>Z</b>
(cg)	18.95"	13.125"		39.88"

1. This pre-approval covers only the supports & attachments of the unit to the structure based on the relation of the Cg and bolt pattern shown at the right.
2. The details in this pre-approval may be used at any location in the state of California where Sds is  $\leq 2.00$
3. The forces shown using Strength Design were obtained from ASCE 7-10 Using Eqn's. 13.3-1,2,3 and Load Combinations 5 & 7 from Section 12.4.3.2 with these parameters Wp=1050 Lbs. Sds=2.00 Ip=1.5 z=0 h=1.0 Z/h=0 At Grade ASCE 7-10 Table 13.6-1: Other Mechanical or Electrical Equipment.  $a_p=1.0$   $R_p=1.5$   $\Omega_0=1.5$  (Where req'd for anchorage to concrete.
4. This pre-approval encompasses all of the weights and Cg locations up to those shown. v070714

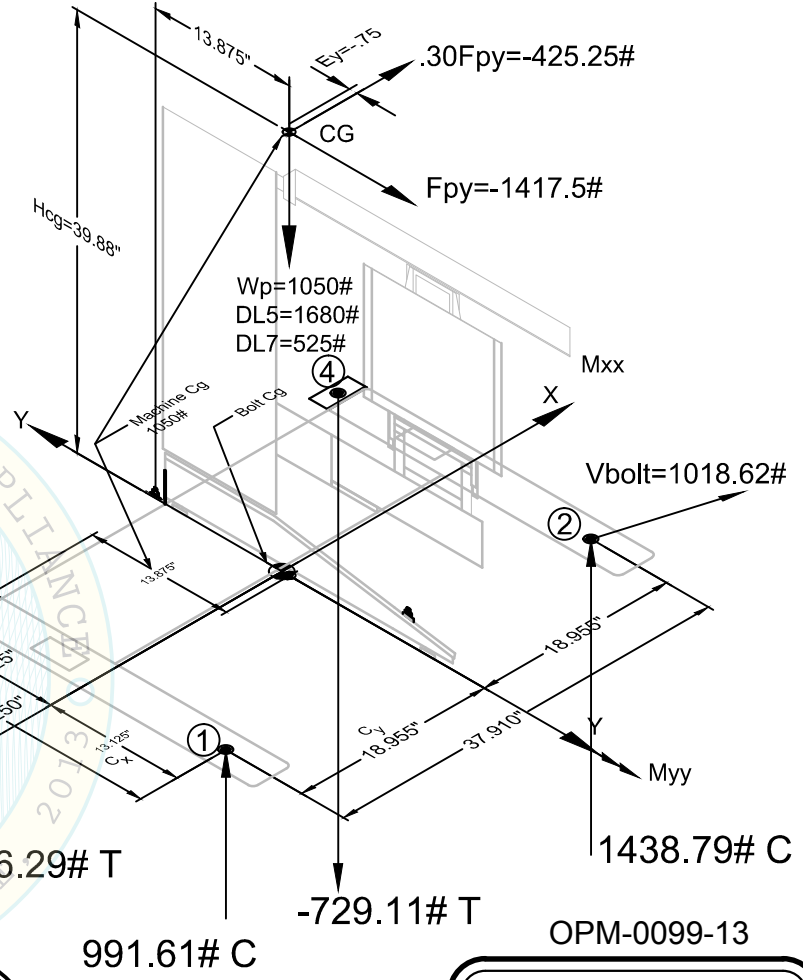
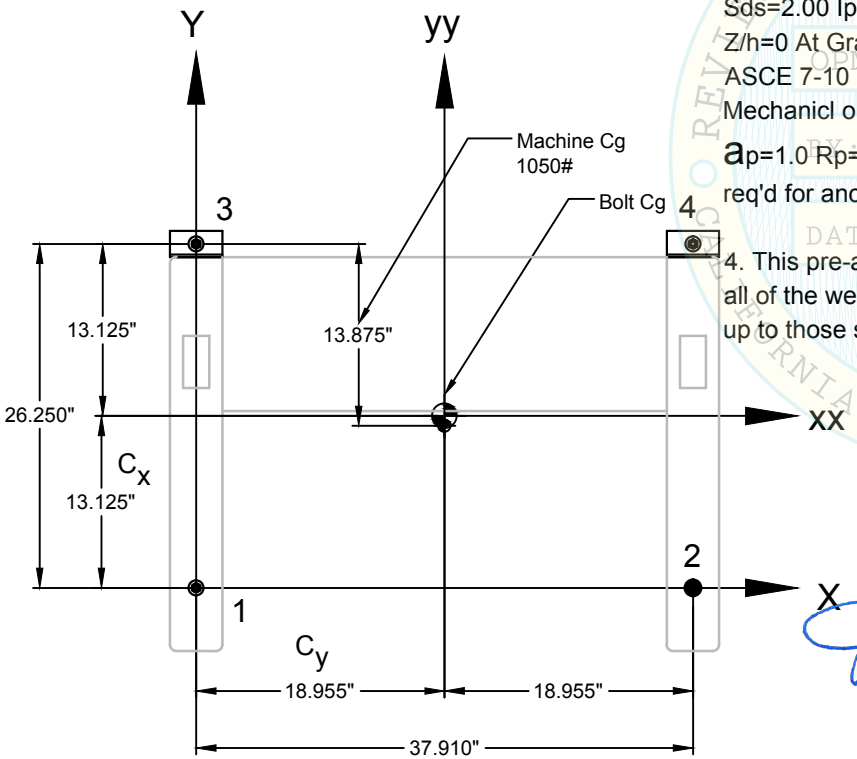

Signed 10-8-2014

**Hologic MultiCare Design Schematic**

**Don Lee Engineering**  
 21008 Sylvanwood Ave.  
 Lakewood, Ca 90715  
 562-860-7896

Project	HL-2013	<b>S0</b>
Date	September 15, 2014	
Scale	None	

**EXPANSION BOLTS**

Version 10-04-2014

1. CONCRETE ANCHORS SHALL BE: HILTI KB-TZ-ESR1917, (CORRECTED August 2014)
2. INSPECTION AND TESTING OF EXPANSION BOLTS SHALL COMPLY WITH 2013 CBC Section 1913A.7 USING THE TORQUE WRENCH METHOD AND IN ACCORDANCE WITH THE PROCEDURES BELOW.
3. TORQUE WRENCHES SHALL BE FLAT OR ROUND BEAM TYPE CALIBRATED BY AN APPROVED LABORATORY IN ACCORDANCE WITH ACCEPTED PROCEDURES.
4. THE BOLTS SHALL BE INSTALLED AS DESCRIBED IN THE APPLICABLE ICC-ESR REPORT.
5. Testing of the post-installed anchors shall be done in the presence of the special inspector and a report of the test results shall be submitted to the enforcement agency.
6. THE HOLES SHALL NOT BE DRILLED UNTIL THE BOLTS TO BE USED ARE ON SITE.
7. INSPECTOR SHALL MEASURE THE LENGTH OF THE BOLTS AND ENSURE THAT THEY ARE THE PROPER PART NUMBER AND LENGTH SHOWN IN DETAIL 3/S2.
8. OBSERVE THE DRILLING OF THE HOLES AND MEASURE THE ACTUAL DEPTH.
9. IF THE HOLE DEPTH EXCEEDS THAT SHOWN IN DETAIL 3/S2, CARE SHALL BE TAKEN WHEN DRIVING THE BOLTS INTO THE HOLES SO THAT THE EXTENSION OF THE BOLT ABOVE THE SURFACE IS AS SHOWN IN DETAIL 3/S2.
10. **INITIAL INSTALLATION:** TIGHTEN ALL ANCHORS ON EACH UNIT TO THE SPECIFIED TORQUE AND HOLD IT FOR 2 MINUTES. THE NUT SHALL NOT CONTINUE TO TURN. THE REQUIRED TORQUE SHALL BE REACHED WITHIN THE NUMBER OF TURNS AND/OR STICK OUT SHOWN IN DETAIL 3/S2.
11. **FINAL TEST A MINIMUM 24 HOURS AFTER INITIAL INSTALLATION.** THE NUTS SHALL REACH THE REQUIRED TORQUE WITHIN 1/2 TURN.
12. BOLT HOLES MAY NOT BE REUSED. MINIMUM DISTANCE BETWEEN NEW BOLT AND ABANDONED HOLE SHALL BE 1-1/2". OLD HOLE SHALL BE FILLED WITH NON-SHRINK GROUT.

**GENERAL NOTES:**

Version 7-7-14

THIS OSHPD PREAPPROVAL OF MANUFACTURER'S CERTIFICATION IS BASED ON THE CBC 2013. THE DEMAND (DESIGN FORCES) FOR USE WITH THIS OPM SHALL BE BASED ON THE CBC 2013.

ALL CONSTRUCTION SHALL COMPLY WITH THE CBC 2013 & ITS REFERENCED STANDARDS.

THE SEISMIC ATTACHMENTS SHOWN ON THESE PLANS COMPLIES WITH THE PROVISIONS OF 2013 CBC 1909A FOR THE QUALIFICATION, DESIGN AND USE OF POST-INSTALLED ANCHORS IN CONCRETE.

THE CONTRACTOR SHALL VERIFY THAT THE SITE CONDITIONS ARE SUITABLE FOR INSTALLATION OF THE EQUIPMENT AS SHOWN ON THESE DRAWINGS AND ANY OTHER APPLICABLE PROJECT DRAWINGS. IF ANY PROBLEMS ARE FOUND, THE PERSON RESPONSIBLE FOR THE PROJECT SHALL BE NOTIFIED IN WRITING LISTING THE PROBLEMS.

LOCATE ALL REINFORCEMENT, CONDUIT, PIPES OR OTHER ITEMS IN THE CONCRETE SLAB PRIOR TO DRILLING THE BOLT HOLES. NOTIFY PERSON IN CHARGE OF THE PROJECT BEFORE CONTINUING IF ANY INTERFERENCE IS FOUND.

THE CONTRACTOR IS RESPONSIBLE FOR COMPLIANCE WITH ALL APPLICABLE CONSTRUCTION SAFETY PROCEDURES.

WHEN THE TEST LAB IS CALLED TO THE SITE, A REPORT MUST BE FILED STATING THE REASON FOR THE CALL AND THE DISPOSITION OF THE CALL.

This pre-approval covers only the supports and attachments of the unit to the structure based on the relation of the Cg and bolt pattern shown on S0.

**The Structural Engineer of Record Shall:**

Version 7-7-14

1. Verify the equipment is anchored to a normal weight concrete slab at grade (Minimum T=5" f'c=2500 Psi), located such that adequate bolt strength and foundation size are provided. The anchors shall meet the requirements of the applicable ICC-ESR.

2. Verify that the anchors are an adequate distance from any slab edge, opening or control joint. (see Detail 1/S2).

3. Verify that all new or existing anchors are an adequate distance from the anchors shown in this pre-approval. SEOR shall verify that there is no adverse interaction where other anchors are within 18" from this unit's anchors.

4. Verify that the installation is in conformance with the 2013 CBC, that the site specific values of S<sub>DS</sub> & z/h do not exceed the values shown on Sheet S0, and with the details shown in this pre-approval. Verify that the actual equipment's weight, CG location, anchor locations, anchor details, and the material and gage of the unit where attachments are made agree with the information shown on the pre-approval documents. Provide any support structure required to support the weights and forces shown in addition to all other required loads.

D:\MyFiles\FLI\AAA DLE Projects\Hologic 2013 OPM Program\Multi-Care\MultiCare OPM-0099-13.dwg, 10/8/2014 12:25:25 PM

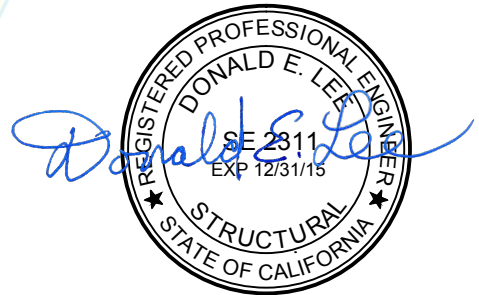
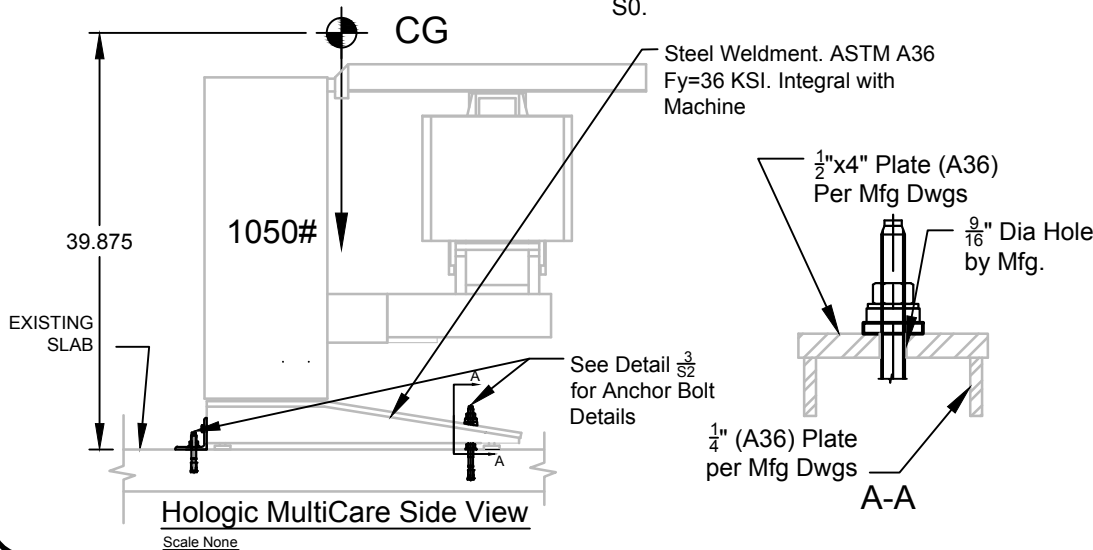

Signed 10-8-2014

OPM-0099-13

**Don Lee Engineering**

21008 Sylvanwood Ave.  
Lakewood, Ca 90715  
562-860-7896

Project	DLE-(A)-014
Date	September 15, 2014
Scale	None

**S1**

3 of 4 10/8/14

D:\MyFiles\FlIAAAA DLE Projects\Hologic 2013 OPM Program\Multi-Care\MultiCare OPM-0099-13.dwg, 10/8/2014 12:23:54 PM

SEE 3 BELOW FOR SIZE OF EXPANSION ANCHORS TYP 4 PLACES

EXISTING JOINTS IN SLAB

CG

1050#

1

2

### MultiCare Installed on Existing Slab

7/16" Dia 3/8"=1'-0"

3x3x1/4" Angle ASTM A-36

5/8" Dia

1

### Multi-Care INSTALLED ON EXISTING CONCRETE SLAB. MINIMUM: 5" THICK, NORMAL WEIGHT fc=2500 PSI

Scale 3/8"=1'-0"

EDGE DISTANCES ARE FOR UNREDUCED BOLT STRENGTH. SEOR IS RESPONSIBLE FOR LOCATING MACHINE SUCH THAT ADEQUATE BOLT STRENGTH AND FOUNDATION SIZE ARE PROVIDED.

These are minimum joint distances and **DO NOT** represent the size of slab required for an adequate foundation.

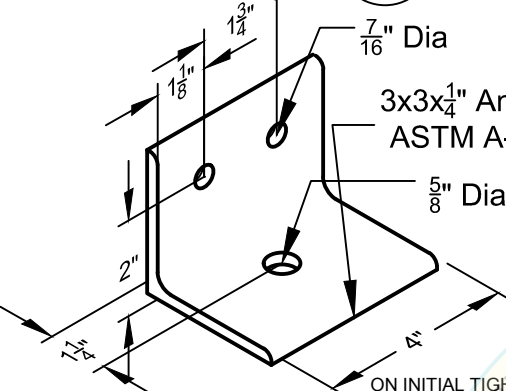

KB-TZ 1/2 X 3 3/4: AS INITIALLY DRIVEN INTO HOLE.

3x3x1/4"x4" L Anchorage Clip See Isometric Above

ON INITIAL TIGHTENING THE BOLT SHALL NOT MOVE UPWARD MORE THAN 6 TURNS, OR THE EXTENSION SHOWN, BEFORE IT REACHES A TORQUE OF 40FT-LB.. THE 40 FT-LBS SHALL BE HELD FOR 2 MINUTES.

ON INITIAL TIGHTENING THE BOLT SHALL NOT MOVE UPWARD MORE THAN 8 TURNS, OR THE EXTENSION SHOWN, BEFORE IT REACHES A TORQUE OF 40FT-LB. THE 40 FT-LBS SHALL BE HELD FOR 2 MINUTES.

ON FINAL TIGHTENING A MINIMUM OF 24 HOURS LATER THE 40 FT-LBS MUST BE REACHED WITHIN 1/2 TURN.

ON FINAL TIGHTENING A MINIMUM OF 24 HOURS LATER THE 40 FT-LBS MUST BE REACHED WITHIN 1/2 TURN.

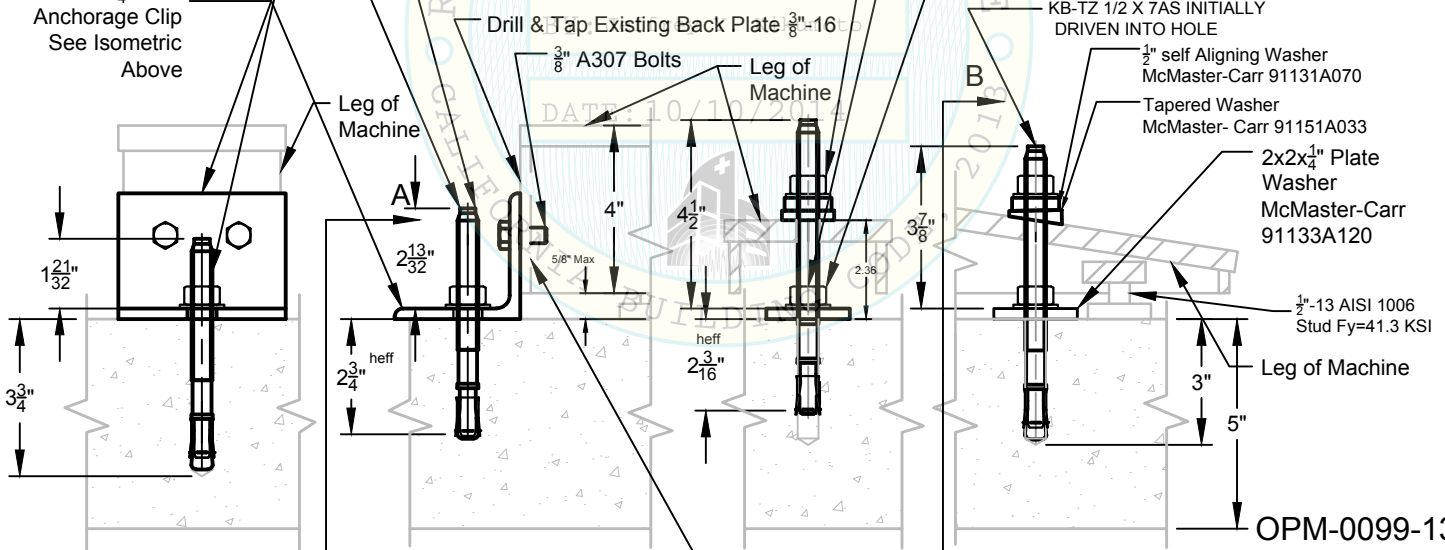

3 S2

### Expansion Bolt Installation Details

Scale None

This pre-approval covers only the supports and attachments of the unit to the structure based on the relation of the Cg and bolt pattern shown on S0.



**Don Lee Engineering**  
 21008 Sylvanwood Ave.  
 Lakewood, Ca 90715  
 562-860-7896

Project	DLE-(A)-014	<b>S2</b>
Date	September 15, 2014	
Scale	None	

**Hologic MultiCare Anchors** Signed 10-8-2014