



**OFFICE OF STATEWIDE HEALTH PLANNING AND DEVELOPMENT
FACILITIES DEVELOPMENT DIVISION**

**APPLICATION FOR OSHPD PREAPPROVAL
OF MANUFACTURER'S CERTIFICATION (OPM)**

OFFICE USE ONLY

APPLICATION #: OPM-0124-13

OSHPD Preapproval of Manufacturer's Certification (OPM)

Type: New Renewal Update to Pre-CBC 2013 OPA Number: _____

Manufacturer Information

Manufacturer: Ergotron

Manufacturer's Technical Representative: Jay Sorlie

Mailing Address: 1181 Trapp Road, St. Paul, MN. 55121

Telephone: (651) 681-7623

Email: Djsorlie@ergotron.com

Product Information

Product Name: VL Wall Mount

Product Type: Computer

Product Model Number: 60-609

General Description: Wall Mounted Monitor and Keyboard Support

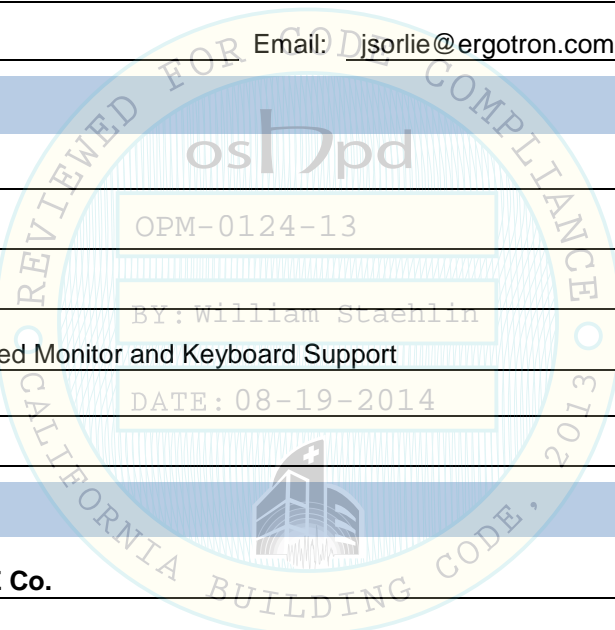

Applicant Information

Applicant Company Name: EASE Co.

Contact Person: Jonathan Roberson, S.E.

Mailing Address: 5877 Pine Ave. Suite 210, Chino Hills, CA. 91709

Telephone: (909) 606-7622

Email: J.Roberson@EASECo.com

I hereby agree to reimburse the Office of Statewide Health Planning and Development review fees in accordance with the California Administrative Code, 2013.

Signature of Applicant: _____

Date: 7/11/14

Title: Principal Engineer

Company Name: EASE Co.

"Access to Safe, Quality Healthcare Environments that Meet California's Diverse and Dynamic Needs"

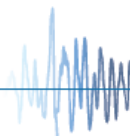



**OFFICE OF STATEWIDE HEALTH PLANNING AND DEVELOPMENT
FACILITIES DEVELOPMENT DIVISION**

Registered Design Professional Preparing Engineering Recommendations

Company Name: EASE Co.

Name: Jonathan Roberson, S.E. California License Number: S4197

Mailing Address: 5877 Pine Ave. Suite 210, Chino Hills, CA. 91709

Telephone: 909-606-7667 Email: J.Roberson@EASECo.com

OSHPD Special Seismic Certification Preapproval (OSP)

- Special Seismic Certification is preapproved under OSP- (Separate application for OSP is required)
- Special Seismic Certification is not preapproved

Certification Method(s)

- Testing in accordance with: ICC-ES AC156 FM 1950-10
- Other* (Please Specify): _____

*Use of test criteria other than those adopted by the California Building Standards Code, 2013 (CBSC 2013) for component supports and attachments are not permitted. For distribution system, interior partition wall, and suspended ceiling seismic bracings, test criteria other than those adopted in the CBSC 2013 may be used when approved by OSHPD prior to testing.

- Analysis
- Experience Data
- Combination of Testing, Analysis, and/or Experience Data (Please Specify): _____

List of Attachments Supporting the Manufacturer's Certification

- Test Report Drawings Calculations Manufacturer's Catalog
- Other(s) (Please Specify): _____

OFFICE USE ONLY – OSHPD APPROVAL VALID FOR CBC 2013 ONLY

Signature: *William Staehlin* Date: 08/19/2014

Print Name: William Staehlin

Title: SSE

Condition of Approval (if applicable): _____



"Access to Safe, Quality Healthcare Environments that Meet California's Diverse and Dynamic Needs"

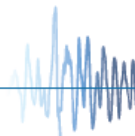



**EQUIPMENT ANCHORAGE
& SEISMIC ENGINEERING**

5877 Pine Ave, Ste. 210
Chino Hills, CA. 91709
Phn: (909) 606-7622

Office of Statewide Health Planning and Development
PREAPPROVAL OF MANUFACTURER'S CERTIFICATION
OPM-0124-13

THIS PREAPPROVAL CONFORMS TO THE 2013 CALIFORNIA BUILDING CODE

MANUFACTURER: **ERGOTRON**
EQUIPMENT NAME: **VL WALL MOUNT**

Sheet: 1 of 3
Date: 7/24/14

GENERAL NOTES

1. THIS OSHPD PREAPPROVAL OF MANUFACTURER'S CERTIFICATION (OPM) IS BASED ON THE 2013 CBC. THE DEMANDS (DESIGN FORCES) FOR USE WITH THIS OPM SHALL BE BASED ON THE 2013 CBC
2. THIS DOCUMENT MAY ONLY BE USED WITH THE EXPRESS WRITTEN CONSENT OF THE MANUFACTURER LISTED ABOVE FOR THE SPECIFIC PROJECT SITE AND INSTALLATION LOCATION. THIS DOCUMENT IS INVALID WITHOUT SUCH CONSENT.
3. THIS PREAPPROVAL CONFORMS TO THE 2013 CALIFORNIA BUILDING CODE.
4. FORCES PER ASCE 7-10 SECTION 13.3.1, EQUATIONS 13.3-1, 13.3-2 & 13.3-3, WHERE $S_{ds} = 2.2$, $a_p = 1.0$, $I_p = 1.5$, $R_p = 2.5$, $z/h \leq 1$.
5. THE DETAILS IN THIS PREAPPROVAL MAY BE USED AT ANY LOCATION IN THE STATE OF CALIFORNIA, WHERE S_{ds} IS NOT GREATER THAN 2.2.
6. ALL DESIGN FORCES SHOWN ON THE DRAWINGS ARE FACTORED LOADS THAT SHALL BE USED FOR STRENGTH DESIGN.
7. SHEET METAL SCREWS SHALL BE TEKS SCREWS BY ITW BUILDEX (ICC ESR-1976).
8. THIS PREAPPROVAL COVERS ONLY THE SUPPORTS AND ATTACHMENTS OF THE EQUIPMENT TO THE STRUCTURE.
9. RESPONSIBILITIES OF THE STRUCTURAL ENGINEER OF RECORD OF THE BUILDING
 - A. PROVIDE SUPPORTING STRUCTURE REQUIRED TO SUPPORT WEIGHTS AND FORCES SHOWN, IN ADDITION TO ALL OTHER LOADS.
 - B. VERIFY THAT THE INSTALLATION IS IN CONFORMANCE WITH THE 2013 CBC AND WITH THE DETAILS SHOWN IN THIS PREAPPROVAL. VERIFY THAT THE ACTUAL EQUIPMENT'S WEIGHT, CG LOCATION, ANCHOR LOCATIONS, ANCHOR DETAILS AND THE MATERIAL AND GAGE OF THE UNIT WHERE ATTACHMENTS ARE MADE AGREE WITH THE INFORMATION SHOWN ON THE PREAPPROVAL DOCUMENTS.
 - C. VERIFY THAT THE COMBINATION OF S_{ds} & z/h RESULT IN SEISMIC FORCES (E_h , E_v) THAT ARE NOT GREATER THAN THE VALUES ON THE DETAILS.
 - D. DESIGN BACKING BARS, STUDS, ETC. WHICH THE UNITS ARE ATTACHED TO AS NOTED ON THE DRAWINGS.



ERGOTRON

VL WALL MOUNT

DES. **J. ROBERSON**

JOB NO. **11-1359**

DATE **7/24/14**

SHEET

2

OF **3** SHEETS

SEISMIC SUPPORTS & ATTACHMENTS

WALL MOUNTED

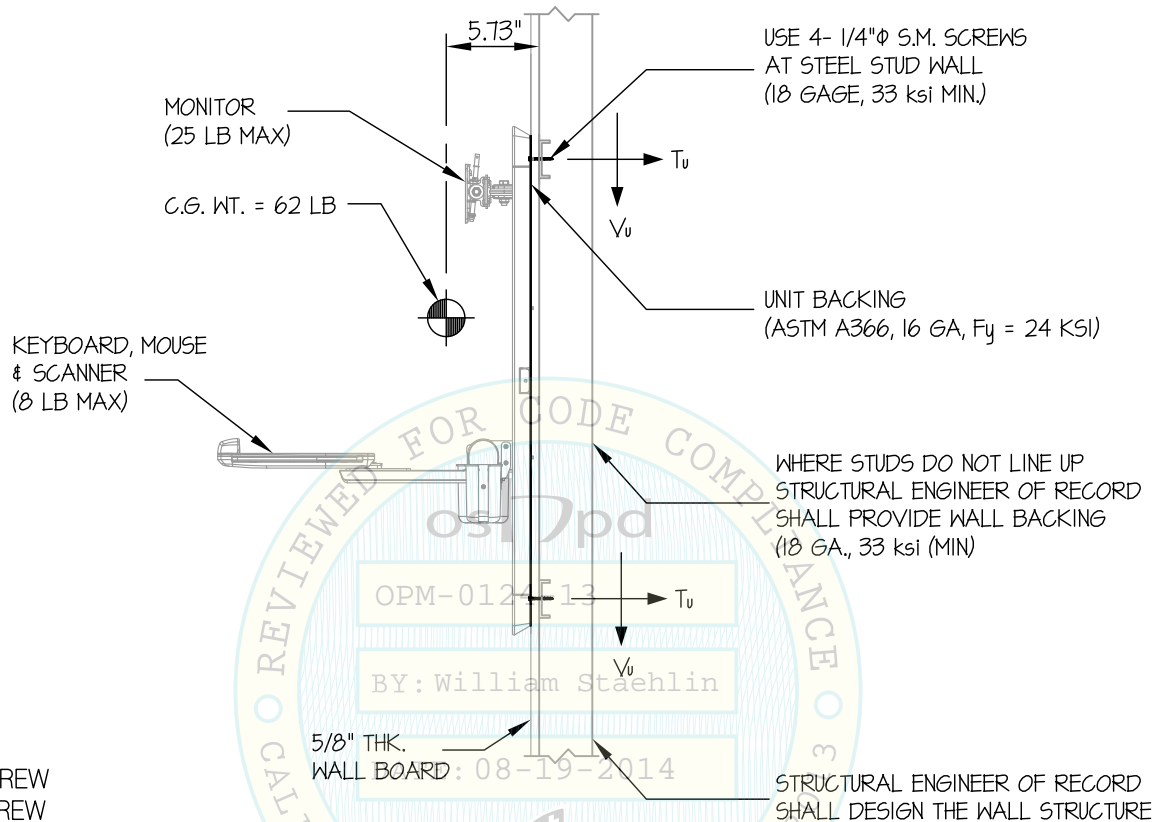

STEEL STUD WALL SECTION

NOTES:

- FORCES ARE DETERMINED PER 2013 CALIFORNIA BUILDING CODE AND ASCE 7-10 STRENGTH DESIGN IS USED. ($S_{ds} = 2.20$, $\alpha_p = 1.0$, $I_p = 15$, $R_p = 2.5$, $z/h \leq 1$)
HORIZONTAL FORCE (E_h) = 158 W_p
VERTICAL FORCE (E_v) = 0.44 W_p
- CENTER OF GRAVITY (C.G.) AND WEIGHT ARE THE GOVERNING PARAMETERS FOR DESIGN. THIS PREAPPROVAL ENCOMPASSES ALL WEIGHTS UP TO THE MAXIMUM WEIGHT SHOWN.
- STRUCTURAL ENGINEER OF RECORD FOR THE BUILDING SHALL PROVIDE SUPPORT STRUCTURE DESIGNED TO SUPPORT WEIGHTS AND FORCES SHOWN, IN COMBINATION WITH ALL OTHER LOADS THAT MAY BE PRESENT.
- SEE GENERAL NOTES: SHEETS 1

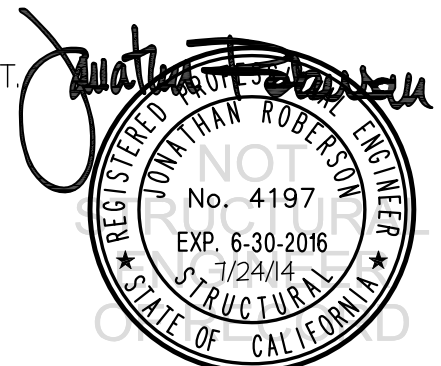

ERGOTRON

VL WALL MOUNT

DES. **J. ROBERSON**

JOB NO. **11-1359**

DATE **7/24/14**

SHEET

3

OF **3** SHEETS

SEISMIC SUPPORTS & ATTACHMENTS

WALL MOUNTED

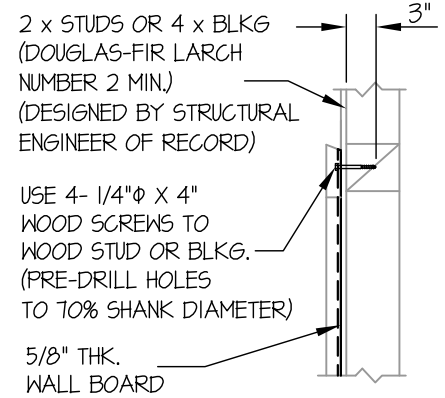
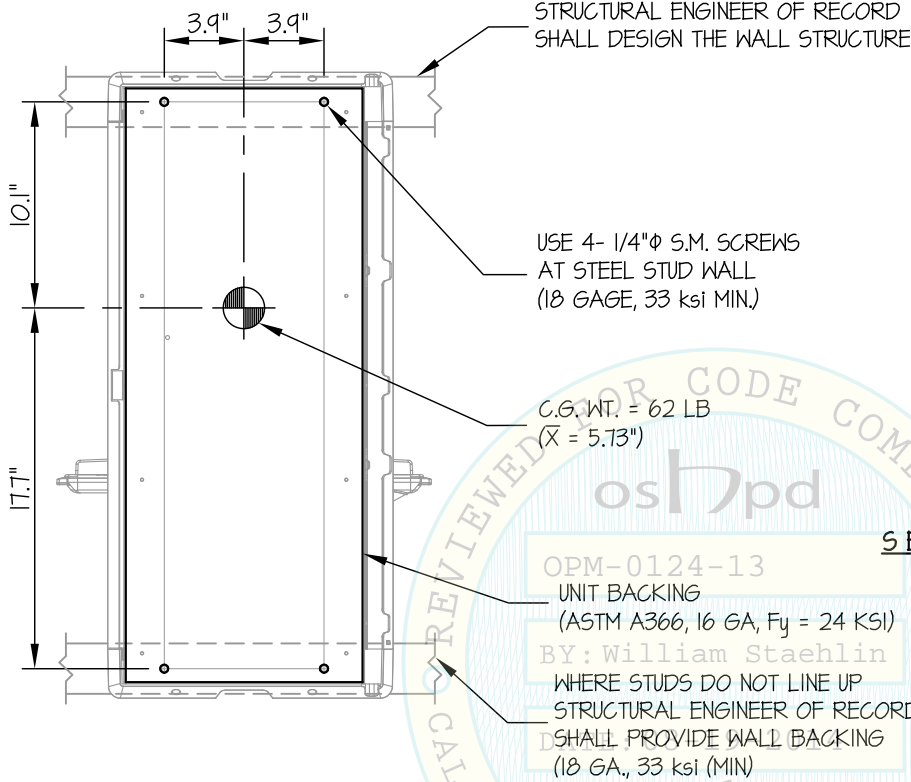

NOTE: WOOD SCREWS TO BE INSTALLED AT CENTERLINE OF 2X WOOD STUD

SECTION AT WOOD STUD WALL

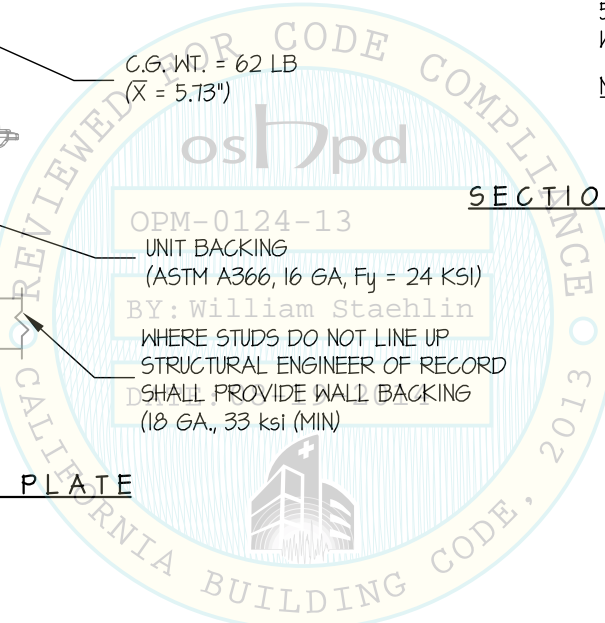

ELEVATION AT WALL PLATE
(STEEL STUD CONDITION)

