



DEPARTMENT OF HEALTH CARE ACCESS AND INFORMATION
OFFICE OF STATEWIDE HOSPITAL PLANNING AND DEVELOPMENT

APPLICATION FOR HCAI PREAPPROVAL OF
MANUFACTURER'S CERTIFICATION (OPM)

OFFICE USE ONLY

APPLICATION #: OPM-0159

HCAI Preapproval of Manufacturer's Certification (OPM)

Type: New Renewal/Update

Manufacturer Information

Manufacturer: IPA, Inc.

Manufacturer's Technical Representative: Kyle Joiner

Mailing Address: 3059 Premiere Parkway Suite 200, Duluth, GA 30097

Telephone: (770) 814-6060

Email: Kjoiner@thinkipa.com

Product Information

Product Name: scrubEX MV DISPENSER/RECEIVER OR scrubEX SV DISPENSER/RECEIVER

Product Type: Other mechanical components constructed of high-deformability materials

Product Model Number: N/A

General Description: Dispenses and receives scrub suits to and from authorized users

Applicant Information

Applicant Company Name: EASE LLC.

Contact Person: Tiffany Tonn

Mailing Address: 1515 FAIRVIEW AVE, STE 205, MISSOULA, MT 59801

Telephone: (406) 541-3273

Email: tiffany@easeco.com

Title: Office Assistant

"A healthier California where all receive equitable, affordable, and quality health care"

STATE OF CALIFORNIA – HEALTH AND HUMAN SERVICES AGENCY





**DEPARTMENT OF HEALTH CARE ACCESS AND INFORMATION
OFFICE OF STATEWIDE HOSPITAL PLANNING AND DEVELOPMENT**

Registered Design Professional Preparing Engineering Recommendations

Company Name: EASE LLC
 Name: Jonathan Roberson California License Number: S4197
 Mailing Address: 5877 Pine Ave., Suite 210, Chino Hills, CA 91709
 Telephone: (951) 295-1892 Email: jon@EASECo.com

Certification Method

Testing in accordance with: ICC-ES AC156 FM 1950 ASHRAE 171 FEMA 461
 Other(s) (Please Specify): _____

*Use of criteria other than those adopted by the California Building Standards Code, 2025 (CBSC 2025) for component supports and attachments are not permitted. For distribution system, interior partition wall, and suspended ceiling seismic bracings, test criteria other than those adopted in the CBSC 2025 may be used when approved by HCAI prior to testing.

Analysis
 Experience Data
 Combination of Testing, Analysis, and/or Experience Data (Please Specify): _____

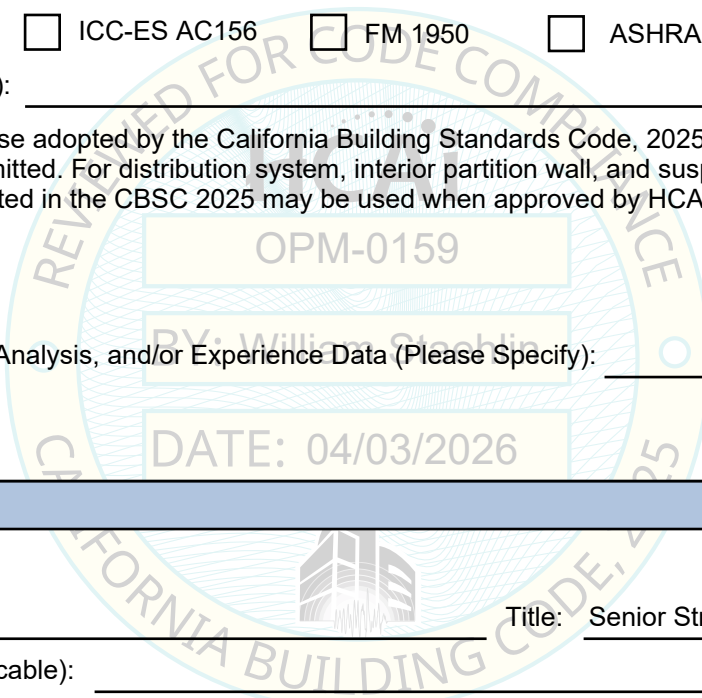

HCAI Approval

Date: 4/3/2026
 Name: William Staehlin Title: Senior Structural Engineer
 Condition of Approval (if applicable): _____

"A healthier California where all receive equitable, affordable, and quality health care"

STATE OF CALIFORNIA – HEALTH AND HUMAN SERVICES AGENCY





**EQUIPMENT ANCHORAGE
& SEISMIC ENGINEERING**

5877 Pine Ave, Ste. 210
Chino Hills, CA. 91709
Phn: (909) 606-7622

Office of Statewide Health Planning and Development
PREAPPROVAL OF MANUFACTURER'S CERTIFICATION
OPM-0159

THIS PREAPPROVAL CONFORMS TO THE 2025 CALIFORNIA BUILDING CODE

MANUFACTURER: **IPA, LLC** Sheet: 1 of 12
EQUIPMENT NAME: **scrubEx MV-Dispenser/Receiver or scrubEx SV-Dispenser/Receiver** Date: 3/31/26

GENERAL NOTES

1. THIS HCAI PREAPPROVAL OF MANUFACTURER'S CERTIFICATION (OPM) IS BASED ON THE 2025 CBC. THE DEMANDS (DESIGN FORCES) FOR USE WITH THIS OPM SHALL BE BASED ON THE 2025 CBC
2. THIS DOCUMENT MAY ONLY BE USED WITH THE EXPRESS WRITTEN CONSENT OF THE MANUFACTURER LISTED ABOVE FOR THE SPECIFIC PROJECT SITE AND INSTALLATION LOCATION. THIS DOCUMENT IS INVALID WITHOUT SUCH CONSENT.
3. THIS PREAPPROVAL CONFORMS TO THE 2025 CALIFORNIA BUILDING CODE WHERE SDS IS NOT GREATER THAN 1.90 & 2.20.
4. FORCES PER ASCE 7-22 SECTION 13.3.1, EQUATIONS 13.3-1, 13.3-2 & 13.3-3,
WHERE $S_{Ds}=2.20, I_p=1.5, C_{AR}=1.0, R_{po}=2.5, z/h=0, (R_{\mu}=1.0, H_f=1.0)$ AT CONCRETE SLAB AT OR BELOW GRADE. SEE FOLLOWING SHEETS FOR Ω_{op}
WHERE $S_{Ds}=1.90, I_p=1.5, C_{AR}=1.0, R_{po}=2.5, z/h \leq 0.95, (R_{\mu}=1.3, H_f=3.375)$ AT CONCRETE SLAB ON METAL DECK.
SEE FOLLOWING SHEETS FOR Ω_{op}
5. THIS PREAPPROVAL COVERS ONLY THE SUPPORTS AND ATTACHMENTS OF THE EQUIPMENT TO THE STRUCTURE.
6. ALL DESIGN FORCES SHOWN ON THE DRAWINGS ARE FACTORED LOADS THAT SHALL BE USED FOR STRENGTH DESIGN.
7. CONCRETE SLAB ON METAL DECK DETAIL VALID FOR DEMANDS SHOWN AT ANY ELEVATION IN THE BUILDING. (i.e. $z/h \leq 0.95$)
8. CONCRETE SLAB DETAIL VALID FOR DEMANDS SHOWN AT OR BELOW GRADE. (i.e. $z/h = 0$)
9. SHEET METAL SCREWS SHALL BE TEKS SCREWS BY ITW BUILDEX (ICC ESR-1976).
10. **RESPONSIBILITIES OF THE STRUCTURAL ENGINEER OF RECORD OF THE BUILDING**
 - A. PROVIDE SUPPORTING STRUCTURE TO SUPPORT WEIGHTS AND FORCES SHOWN IN ADDITION TO ALL OTHER LOADS.
 - B. VERIFY THAT THE INSTALLATION IS IN CONFORMANCE WITH THE 2025 CBC AND WITH THE DETAILS, MATERIAL AND GAGE OF THE UNIT WHERE ATTACHMENTS ARE MADE AGREE WITH THE INFORMATION SHOWN ON THE PREAPPROVAL DOCUMENTS.
 - C. VERIFY THAT PROJECT SPECIFIC SEISMIC PARAMETERS RESULT IN SEISMIC FORCES (E_h, E_v) THAT DO NOT EXCEED THE VALUES IN THIS OPM.
 - D. VERIFY THAT THE CONCRETE SLAB TO WHICH THE EQUIPMENT IS ANCHORED MEETS THE REQUIREMENTS OF THE APPLICABLE ICC ESR REPORT AND THIS OPM.
 - E. VERIFY THAT THE ANCHORS ARE AN ADEQUATE DISTANCE FROM ANY SLAB EDGES OR OPENINGS (SEE TYPICAL DETAIL ON SHEET 2).
 - F. VERIFY THAT ALL NEW OR EXISTING ANCHORS ARE AN ADEQUATE DISTANCE FROM THE UNIT ATTACHMENTS AND CHECK FOR INTERACTION WHERE OTHER ANCHORS ARE WITHIN 18" OR $6h_{ef}$ FROM THIS UNIT'S ANCHORS.



IPA, LLC

DES. **J. ROBERSON**

SHEET

2

JOB NO. **11-2520**

DATE **3/31/26**

OF **12** SHEETS

scrubEx MV-Dispenser/Receiver or scrubEx SV-Dispenser/Receiver

11. EXPANSION ANCHORS:

- A. ATTACHMENT IS TO BE MADE WITH THE ANCHORS LISTED BELOW AND INSTALLED AS DESCRIBED IN THE CORRESPONDING ICC REPORT.

Anchor Diameter	Concrete Type	Min. f'c (psi)	Anchor Type	ICC Report No.	Min. Embed.	Min. Spacing	Min. Edge Dist.	Min. Conc. Thickness	Torque Test	Direct Tension Test
3/8"	Sand Light Weight	3000	Hilti Kwik Bolt TZ2 (CARBON STEEL)	ESR-4266	2"	6.75"	12"	See Detail "A"	30 FT-LB	N/A
1/2"	Normal Weight	3000	Hilti Kwik Bolt TZ2 (CARBON STEEL)	ESR-4266	3.25"	12"	21"	6"	50 FT-LB	3324 lb
5/8"	Normal Weight	3000	Hilti Kwik Bolt TZ2 (CARBON STEEL)	ESR-4266	4"	11"	26"	6"	40 FT-LB	4350 lb

- B. THIS PREAPPROVAL ALLOWS FOR UP TO A MAXIMUM OF 2 ADJACENT CONCRETE SLAB EDGES, 21" & 26" AWAY MINIMUM (i.e. - CORNER). SEE ADJACENT DETAIL FOR ADDITIONAL MINIMUM ALLOWABLE CONCRETE EDGE DISTANCES.

- C. TESTING AND SPECIAL INSPECTION OF EXPANSION ANCHORS SHALL BE PERFORMED BY AN APPROVED INDEPENDENT AGENCY EMPLOYED BY THE FACILITY OWNER PER CBC 1704A & 1910A.5 AND CAC 7-149. ALL REPORTS SHALL BE SENT TO THE INSPECTOR OF RECORD, OWNER AND THE ARCHITECT OR ENGINEER IN RESPONSIBLE CHARGE.

- (i) DIRECT PULL TENSION TEST OR TORQUE TEST AT LEAST 50% OF THE ANCHORS.
- (ii) ACCEPTANCE CRITERIA:
 - DIRECT TENSION TEST: THE ANCHOR SHOULD HAVE NO OBSERVABLE MOVEMENT AT THE TEST LOAD. A PRACTICAL WAY TO DETERMINE OBSERVABLE MOVEMENT IS THAT THE WASHER BECOMES LOOSE.
 - TORQUE TEST: THE APPLICABLE TORQUE MUST BE ACHIEVED WITHIN THE FOLLOWING LIMITS: WEDGE TYPE : 1/2 TURN OF THE NUT

- (iii) IF ANY ANCHOR FAILS, TEST ALL ANCHORS.

- D. AVOID DAMAGING EXISTING STEEL REINFORCING IN CONCRETE SLAB WHEN INSTALLING CONCRETE EXPANSION ANCHORS.
- E. PROVIDE FOR FULL THREAD ENGAGEMENT OF NUT & WASHER.

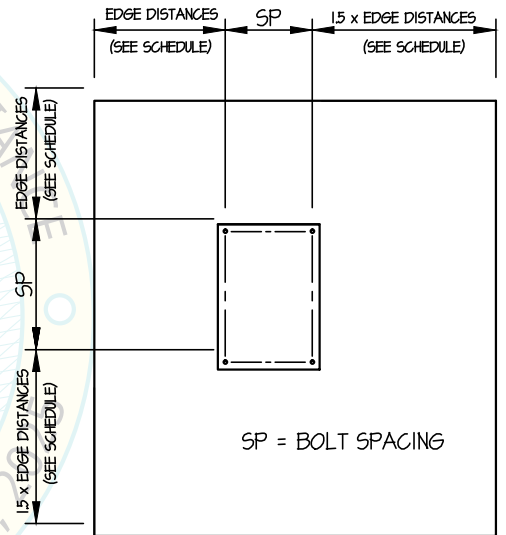

11. BOLTS THROUGH CONCRETE ON METAL DECK

- A. BOLTS SHALL BE TORQUED BY 3/4 TURN OF THE NUTS AFTER THE SNUG TIGHT (THE SNUG-TIGHT CONDITION IS DEFINED AS THE TIGHTNESS REQUIRED TO BRING THE CONNECTED PLIES INTO FIRM CONTACT) CONDITION IS ACHIEVED, UNLESS OTHERWISE NOTED.
- B. THROUGH BOLT HOLES SHALL BE 1/16" LARGER THAN BOLT SIZE (HOLE SIZE = BOLT SIZE + 1/16) FOR CONCRETE.
- C. THROUGH-BOLTS IN CONCRETE SHALL RECEIVE SPECIAL INSPECTION AND TESTING (THROUGH BOLTS WITH STEEL TO STEEL CONNECTION IN TENSION DO NOT REQUIRE TENSION TESTING) IN ACCORDANCE WITH REQUIREMENTS FOR POST-INSTALLED ANCHORS.



IPA, LLC

DES. **J. ROBERSON**

SHEET

3

**scrubEx MV-Dispenser/Receiver or
scrubEx SV-Dispenser/Receiver**

JOB NO. **11-2520**

DATE **3/31/26**

OF **12** SHEETS

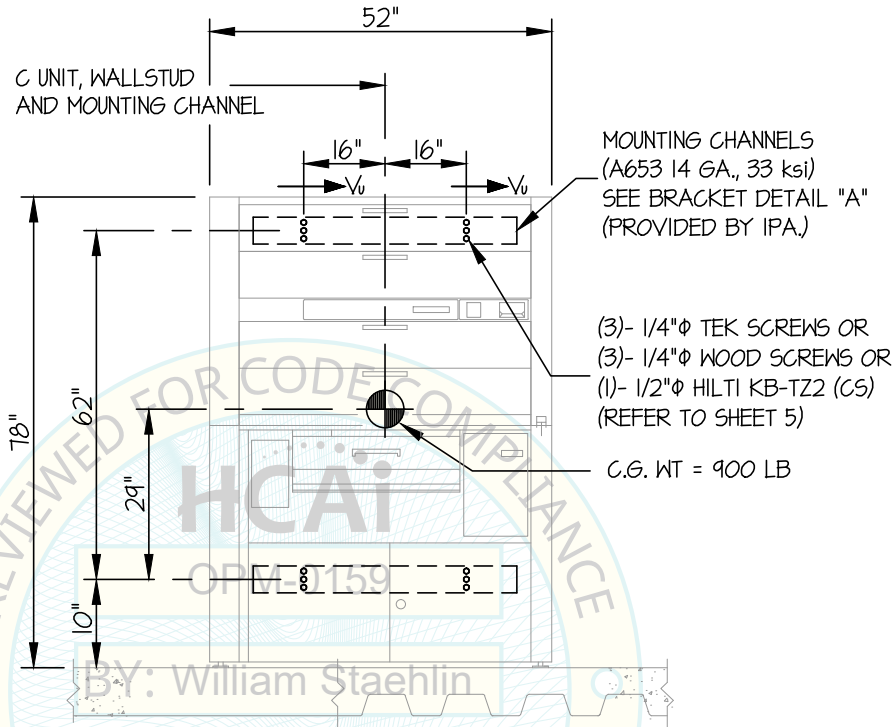

$T_u = 186$ LB/SCREW (MAX)
 $V_u = 157$ LB/SCREW (MAX)
(VALUES DO NOT INCLUDE Ω_{op})

DATE: 04/03/2026

NOTES:

- FORCES ARE DETERMINED PER 2025 CALIFORNIA BUILDING CODE AND ASCE 7-22. STRENGTH DESIGN IS USED. (EXAMPLE: $S_{Ds}=1.90$, $I_p=1.5$, $CAR=1.0$, $R_{po}=2.5$, $\Omega_{op}=2.0$, $R_j=1.3$, $H_f=3.375$, $z/h \leq 0.95$)
 HORIZONTAL FORCE (E_h) = $1.97 W_p$
 HORIZONTAL FORCE (E_{mh}) = $3.94 W_p$ (FOR CONCRETE ANCHORAGE)
 VERTICAL FORCE (E_v) = $0.38 W_p$
- THIS PREAPPROVAL ENCOMPASSES WEIGHTS AND VERTICAL C.G. POSITIONS NOT EXCEEDING VALUES SHOWN.
- THIS PREAPPROVAL WAS PREPARED WITHOUT KNOWLEDGE OF ANY SITE CONDITION. COMPATIBILITY FOR USE WITH A SITE SHALL BE EVALUATED BY THE STRUCTURAL ENGINEER OF RECORD OF THE INSTALLATION (SEOR). USE REQUIRES APPROVAL BY THE SEOR.
- STRUCTURAL ENGINEER OF RECORD FOR THE INSTALLATION SHALL VERIFY ALL CONDITIONS, EVALUATE INTERACTION WITH ADJACENT EQUIPMENT AND ANCHORS, AND PROVIDE SUPPORT STRUCTURE DESIGNED TO SUPPORT WEIGHTS AND FORCES SHOWN IN COMBINATION WITH ALL OTHER LOADS THAT MAY BE PRESENT.
- SEE GENERAL NOTES: SHEET 1 AND 2.



IPA, LLC

DES. J. ROBERSON

SHEET

4

JOB NO. 11-2520

DATE 3/31/26

OF 12 SHEETS

scrubEx MV-Dispenser/Receiver or scrubEx SV-Dispenser/Receiver

SEISMIC SUPPORTS & ATTACHMENTS

$S_Ds \leq 1.90$

WALL MOUNTED

SEE SHEET 6 FOR UNIT
TO CHANNEL, CHANNEL TO
CHANNEL & CHANNEL TO
WALL CONNECTIONS

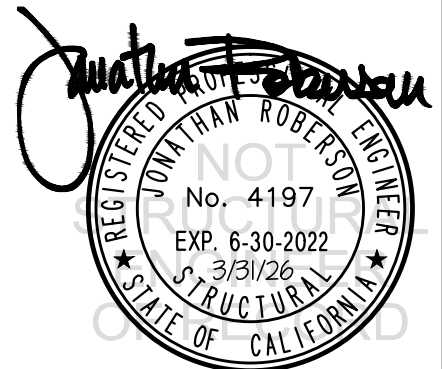
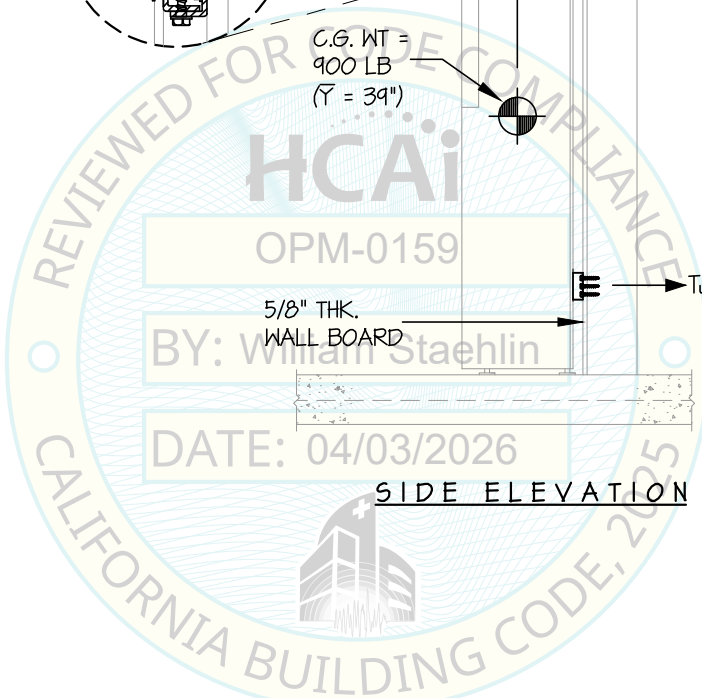
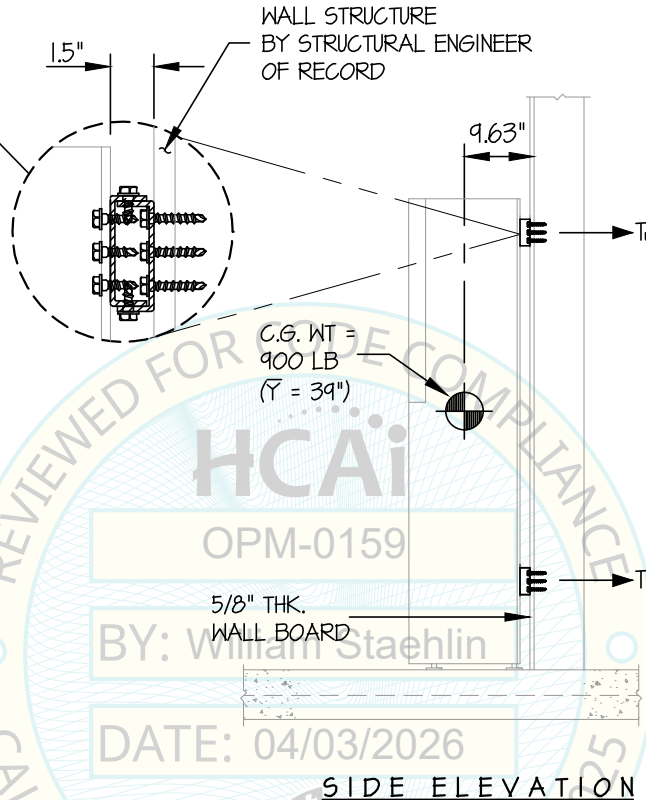

IPA, LLC

DES. **J. ROBERSON**

SHEET

5

JOB NO. **11-2520**

DATE **3/31/26**

OF **12** SHEETS

scrubEx MV-Dispenser/Receiver or scrubEx SV-Dispenser/Receiver

SEISMIC SUPPORTS & ATTACHMENTS

MOUNTING WALL TYPE:

WALL MOUNTED

CONCRETE WALL

(3000 PSI MIN)
BY STRUCTURAL
ENGINEER OF RECORD

UNIT TO MOUNTING CHANNEL
CONNECTION BY MFR
(SEE BRACKET DETAIL "A"
FOR UNIT TO CHANNEL
CONNECTION, TYP)

USE (1)- 1/2"Φ HILTI KB-TZ2 (CS)
EXPANSION ANCHORS
(MIN. EMBED. (h_{ef}) = 3.25")
(2 PER CHANNEL, 4 TOTAL)

$T_u = (3)(186)(2.0) = 1116$ LB/BOLT (MAX)
 $V_u = (3)(157)(2.0) = 942$ LB/BOLT (MAX)
(VALUES INCLUDE Ω_p)

SECTION AT CONCRETE WALL

UNIT TO MOUNTING CHANNEL
CONNECTION BY MFR
(SEE BRACKET DETAIL "A"
FOR UNIT TO CHANNEL
CONNECTION, TYP)

USE (3)- 1/4"Φ X 1 1/2" TEK SCREWS
TO 16 GA, 50 KSI WALL STUD/BLKG
(6 PER CHANNEL, 12 TOTAL)

5/8" THK.
WALL BOARD

WALL BACKING, IT'S
CONNECTION TO THE
WALL STRUCTURE AND
THE WALL STRUCTURE
ITSELF, SHALL BE
DESIGNED BY STRUCTURAL
ENGINEER OF RECORD

$T_u = 186$ LB/SCREW (MAX)
 $V_u = 157$ LB/SCREW (MAX)
(VALUES DO NOT INCLUDE Ω_p)

SECTION AT STEEL STUD WALL

AT EA. MOUNTING CHANNEL
USE (3)- 1/4"Φ x 3.5" WOOD
SCREWS TO WOOD STUD/BLKG
(PRE-DRILL HOLES TO
70% SHANK DIAMETER)
(6 PER CHANNEL, 12 TOTAL)

UNIT TO MOUNTING CHANNEL
CONNECTION BY MFR
(SEE BRACKET DETAIL "A"
FOR UNIT TO CHANNEL
CONNECTION, TYP)

5/8" THK.
WALL BOARD

SECTION AT WOOD STUD WALL

2 X STUDS OR
6X BLOCKING (DOUGLAS-FIR LARCH
NUMBER 2 MINIMUM) CONNECTED TO
WOOD STRUCTURE DESIGNED BY
STRUCTURAL ENGINEER OF RECORD

$T_u = 186$ LB/SCREW (MAX)
 $V_u = 157$ LB/SCREW (MAX)
(VALUES DO NOT INCLUDE Ω_p)

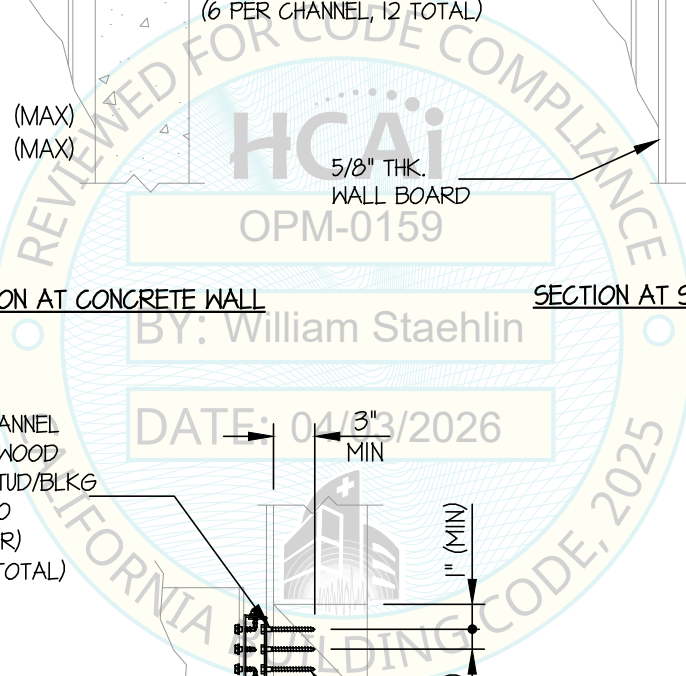

IPA, LLC

DES. **J. ROBERSON**

SHEET

6

JOB NO. **11-2520**

DATE **3/31/26**

OF **12** SHEETS

scrubEx MV-Dispenser/Receiver or scrubEx SV-Dispenser/Receiver

SEISMIC SUPPORTS & ATTACHMENTS

WALL STRUCTURE WALL BRACKET DETAIL

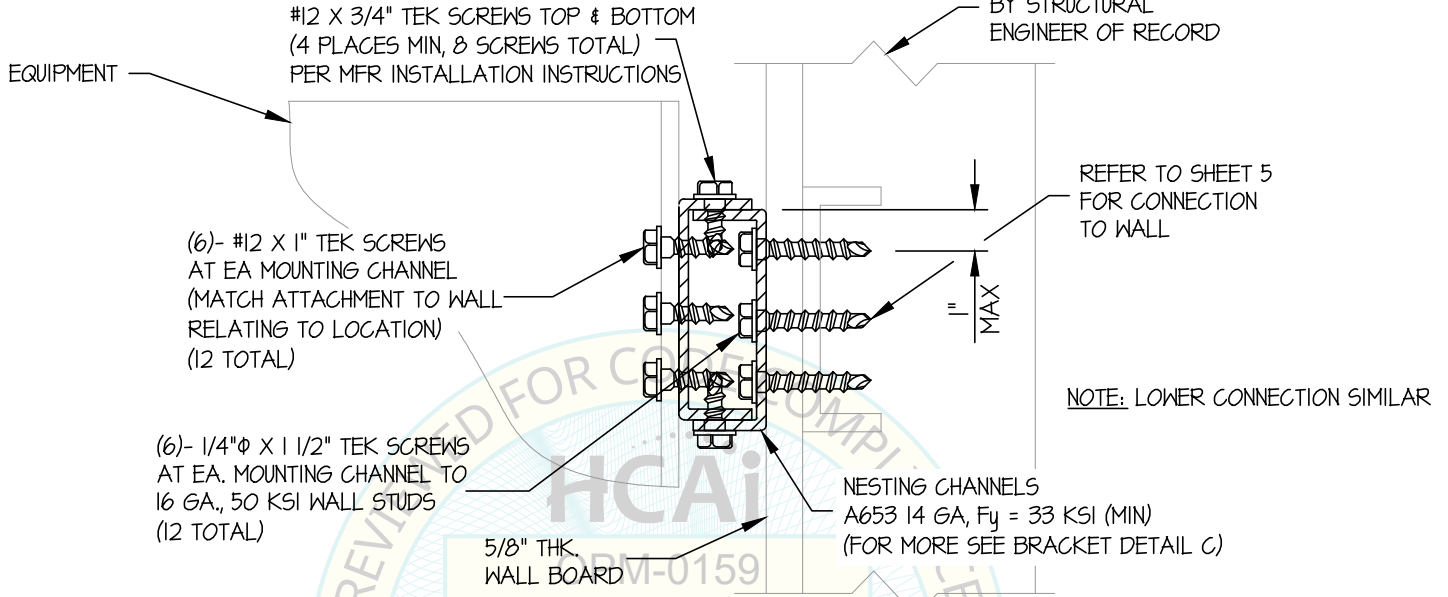

BRACKET DETAIL A

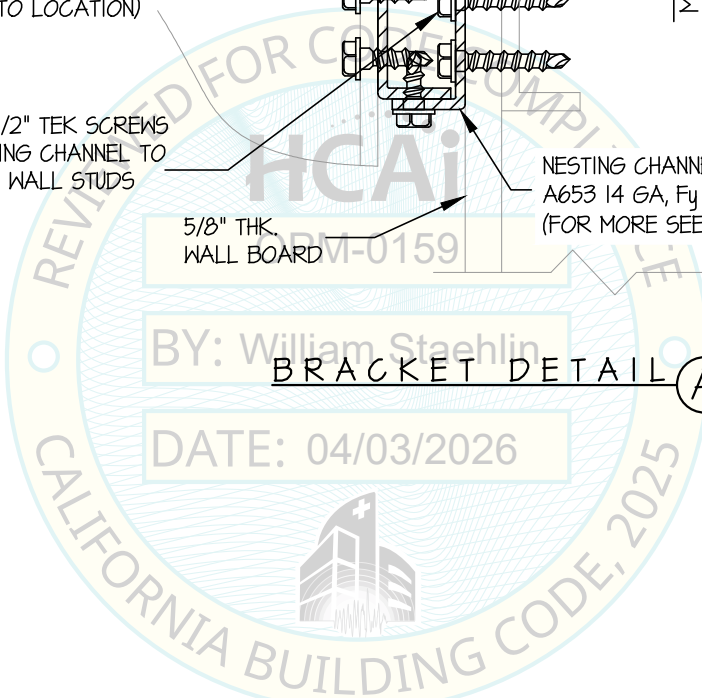

IPA, LLC

DES. **J. ROBERSON**

SHEET

7

JOB NO. **11-2520**

DATE **3/31/26**

OF **12** SHEETS

**scrubEx MV-Dispenser/Receiver or
scrubEx SV-Dispenser/Receiver**

SEISMIC SUPPORTS & ATTACHMENTS

FLOOR MOUNTED

CONCRETE SLAB AT OR BELOW GRADE

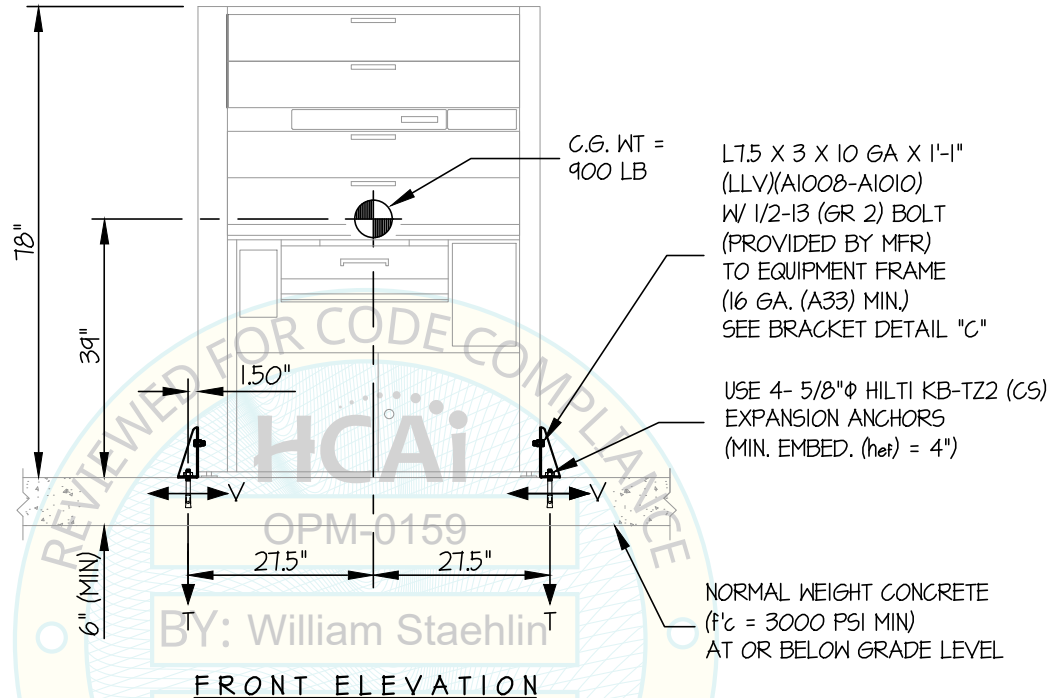

$T_u = 3253$ LB/BOLT (MAX)
 $V_u = 620$ LB/BOLT (MAX)
(VALUES INCLUDE Ω_{cp})

FRONT ELEVATION

DATE: 04/03/2026

NOTES:

- FORCES ARE DETERMINED PER 2025 CALIFORNIA BUILDING CODE AND ASCE 7-22. STRENGTH DESIGN IS USED. (EXAMPLE: $S_{ds}=2.20$, $I_p=1.5$, $CAR=1.0$, $R_{po}=2.5$, $\Omega_{cp}=2.0$, $R_U=1.0$, $H_f=1.0$, $z/h=0$)
 HORIZONTAL FORCE (E_h) = $0.99 W_p$
 HORIZONTAL FORCE (E_{mh}) = $1.98 W_p$ (FOR CONCRETE ANCHORAGE)
 VERTICAL FORCE (E_v) = $0.44 W_p$
- THIS PREAPPROVAL ENCOMPASSES WEIGHTS AND VERTICAL C.G. POSITIONS NOT EXCEEDING VALUES SHOWN.
- THIS PREAPPROVAL WAS PREPARED WITHOUT KNOWLEDGE OF ANY SITE CONDITION. COMPATIBILITY FOR USE WITH A SITE SHALL BE EVALUATED BY THE STRUCTURAL ENGINEER OF RECORD OF THE INSTALLATION (SEOR). USE REQUIRES APPROVAL BY THE SEOR.
- STRUCTURAL ENGINEER OF RECORD FOR THE INSTALLATION SHALL VERIFY ALL CONDITIONS, EVALUATE INTERACTION WITH ADJACENT EQUIPMENT AND ANCHORS, AND PROVIDE SUPPORT STRUCTURE DESIGNED TO SUPPORT WEIGHTS AND FORCES SHOWN IN COMBINATION WITH ALL OTHER LOADS THAT MAY BE PRESENT.
- SEE GENERAL NOTES: SHEET 1 AND 2.



IPA, LLC

DES. **J. ROBERSON**

SHEET

8

JOB NO. **11-2520**

DATE **3/31/26**

OF **12** SHEETS

**scrubEx MV-Dispenser/Receiver or
scrubEx SV-Dispenser/Receiver**

SEISMIC SUPPORTS & ATTACHMENTS

FLOOR MOUNTED

CONCRETE SLAB AT OR BELOW GRADE

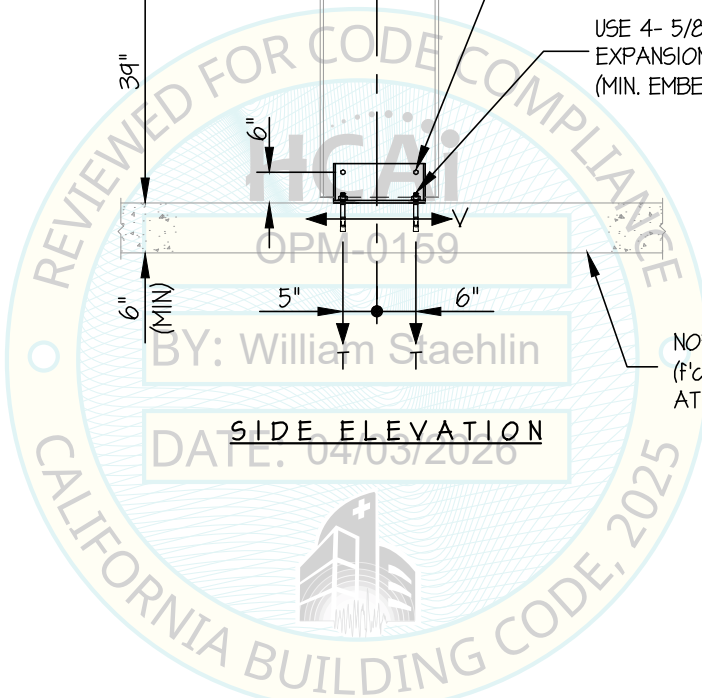
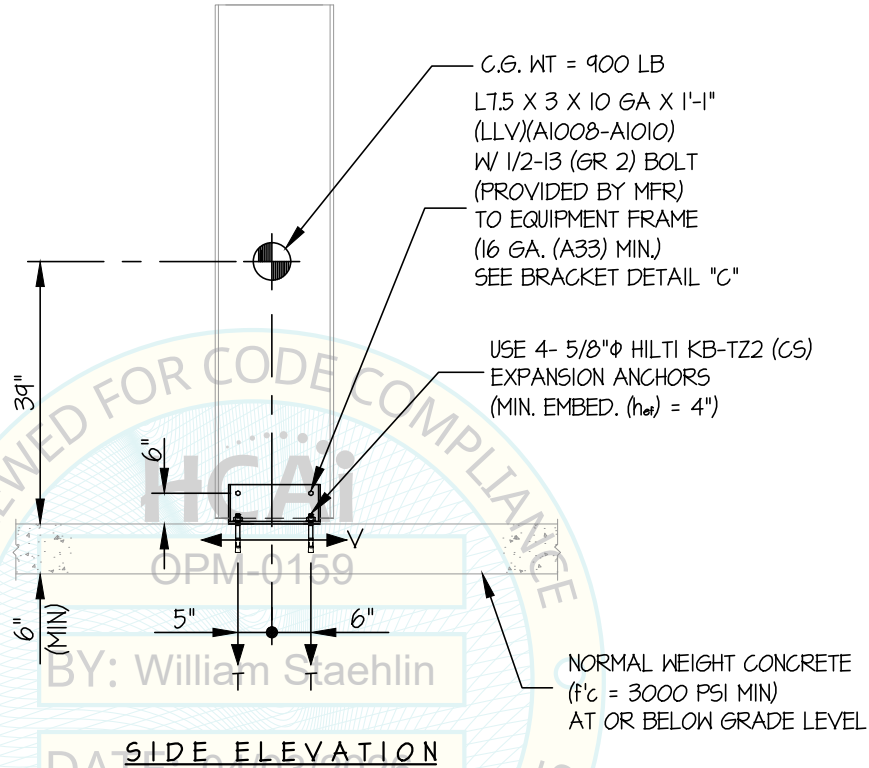

IPA, LLC

DES. **J. ROBERSON**

SHEET

9

**scrubEx MV-Dispenser/Receiver or
scrubEx SV-Dispenser/Receiver**

JOB NO. **11-2520**

DATE **3/31/26**

OF **12** SHEETS

SEISMIC SUPPORTS & ATTACHMENTS

FLOOR MOUNTED

CONCRETE SLAB ON METAL DECK

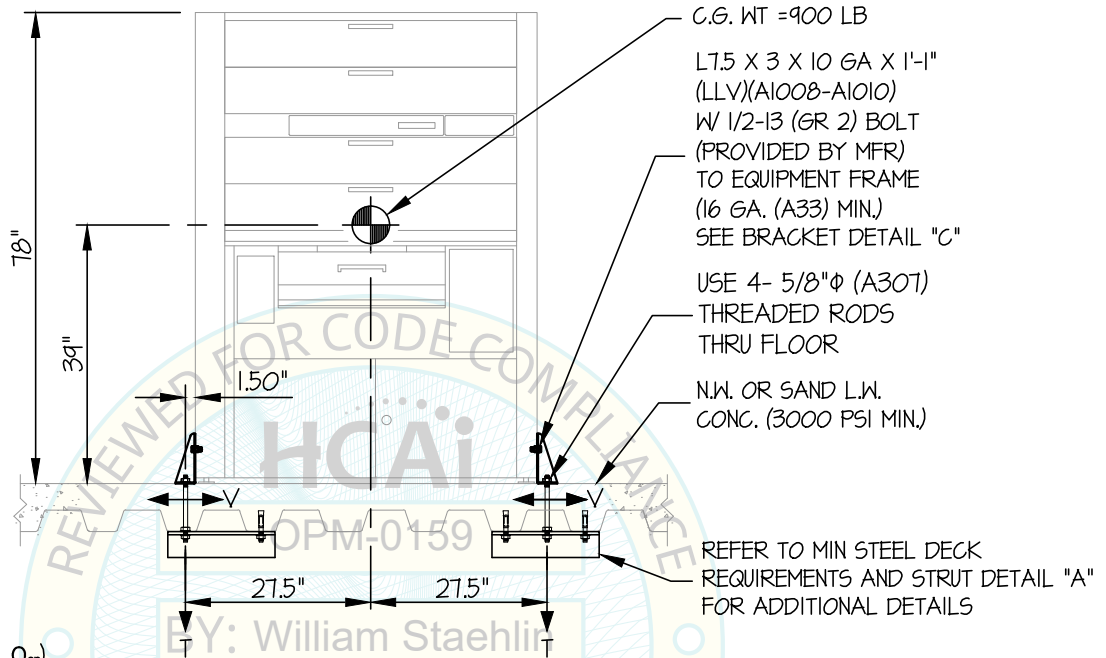

$T_u = 3221 \text{ LB/BOLT (MAX)}$
 $V_u = 617 \text{ LB/BOLT (MAX)}$
 (VALUES DO NOT INCLUDE Ω_{cp})

FRONT ELEVATION

NOTES:

- FORCES ARE DETERMINED PER 2025 CALIFORNIA BUILDING CODE AND ASCE 7-22. STRENGTH DESIGN IS USED. (EXAMPLE: $S_{ds}=1.90$, $I_p=1.5$, $CAR=1.0$, $R_{po}=2.5$, $\Omega_{cp}=2.0$, $R_u=1.3$, $H_f=3.375$, $z/h \leq 0.95$)
 HORIZONTAL FORCE (E_h) = $1.97 W_p$
 HORIZONTAL FORCE (E_{mh}) = $3.94 W_p$ (FOR CONCRETE ANCHORAGE)
 VERTICAL FORCE (E_v) = $0.38 W_p$
- THIS PREAPPROVAL ENCOMPASSES WEIGHTS AND VERTICAL C.G. POSITIONS NOT EXCEEDING VALUES SHOWN.
- THIS PREAPPROVAL WAS PREPARED WITHOUT KNOWLEDGE OF ANY SITE CONDITION. COMPATIBILITY FOR USE WITH A SITE SHALL BE EVALUATED BY THE STRUCTURAL ENGINEER OF RECORD OF THE INSTALLATION (SEOR). USE REQUIRES APPROVAL BY THE SEOR.
- STRUCTURAL ENGINEER OF RECORD FOR THE INSTALLATION SHALL VERIFY ALL CONDITIONS, EVALUATE INTERACTION WITH ADJACENT EQUIPMENT AND ANCHORS, AND PROVIDE SUPPORT STRUCTURE DESIGNED TO SUPPORT WEIGHTS AND FORCES SHOWN IN COMBINATION WITH ALL OTHER LOADS THAT MAY BE PRESENT.
- SEE GENERAL NOTES: SHEET 1 AND 2.



IPA, LLC

DES. **J. ROBERSON**

SHEET

10

scrubEx MV-Dispenser/Receiver or scrubEx SV-Dispenser/Receiver

JOB NO. **11-2520**

DATE **3/31/26**

OF **12** SHEETS

SEISMIC SUPPORTS & ATTACHMENTS

FLOOR MOUNTED

CONCRETE SLAB ON METAL DECK

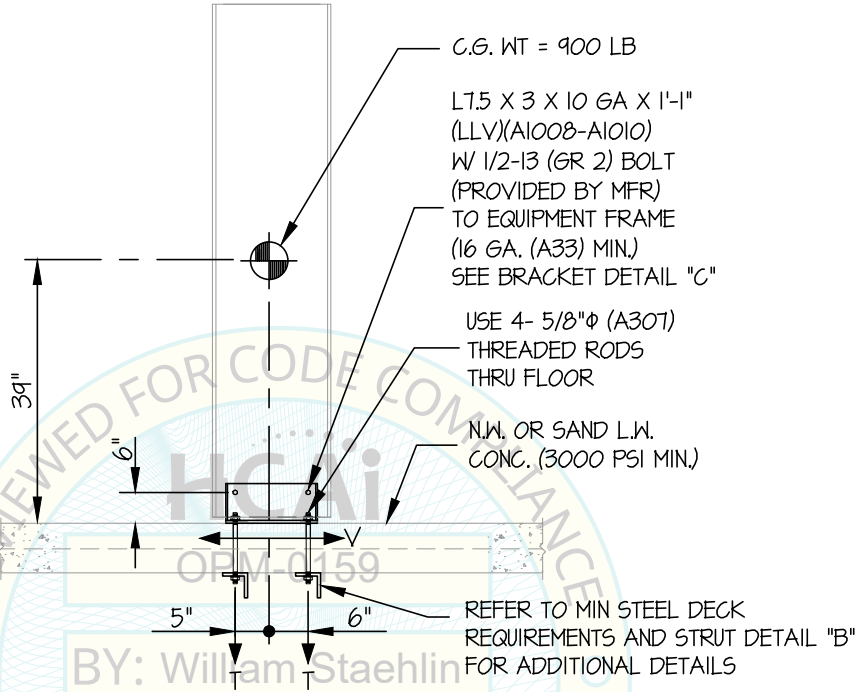

SIDE ELEVATION

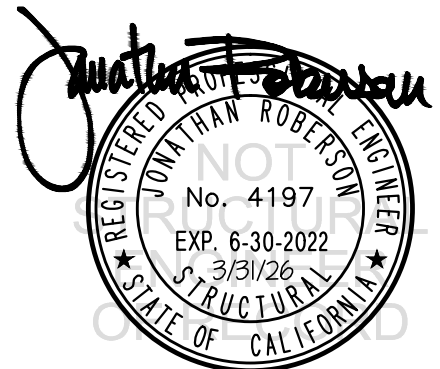

IPA, LLC

DES. **J. ROBERSON**

SHEET

11

JOB NO. **11-2520**

DATE **3/31/26**

OF **12** SHEETS

**scrubEx MV-Dispenser/Receiver or
scrubEx SV-Dispenser/Receiver**

SEISMIC SUPPORTS & ATTACHMENTS

CONCRETE DETAIL

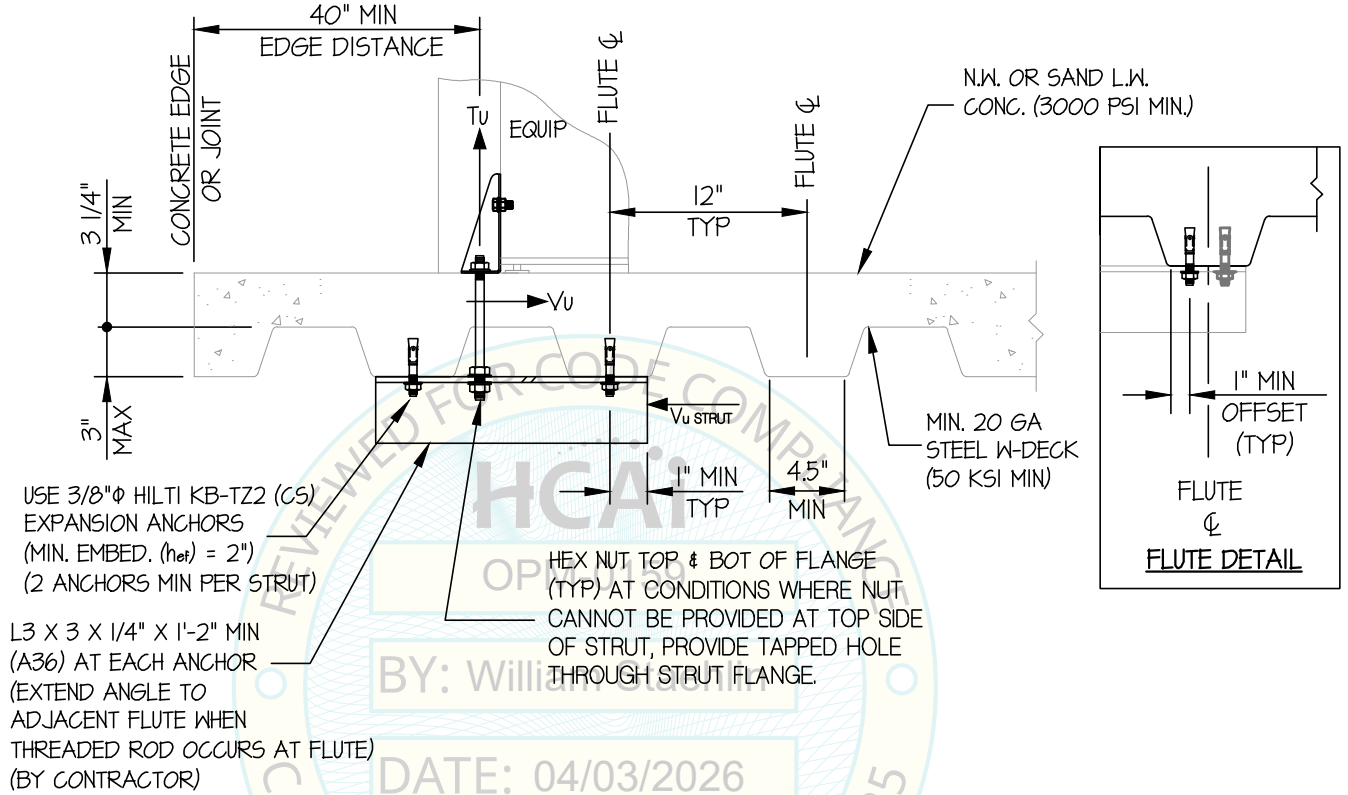

MIN STEEL DECK REQUIREMENTS AND STRUT DETAIL (B)

Jonathan Roberson

REGISTERED PROFESSIONAL ENGINEER
JONATHAN ROBERSON
No. 4197
EXP. 6-30-2022
3/31/26
STRUCTURAL
STATE OF CALIFORNIA

IPA, LLC

DES. **J. ROBERSON**

SHEET

12

**scrubEx MV-Dispenser/Receiver or
scrubEx SV-Dispenser/Receiver**

JOB NO. **11-2520**

DATE **3/31/26**

OF **12** SHEETS

SEISMIC SUPPORTS & ATTACHMENTS

BRACKET DETAIL

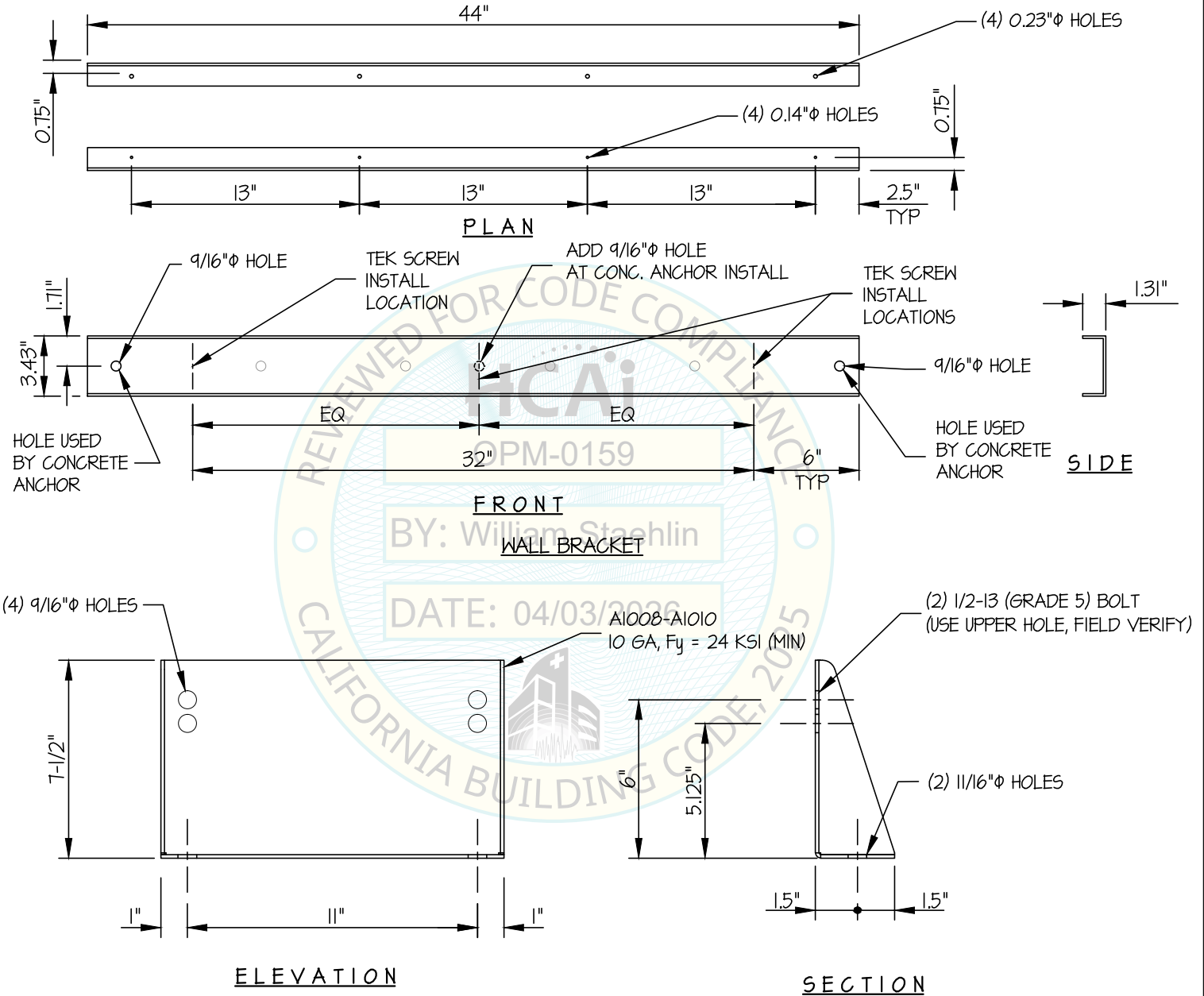

FLOOR BRACKET

BRACKET DETAILS ©
 (BRACKETS BY MFR)

