



**OFFICE OF STATEWIDE HEALTH PLANNING AND DEVELOPMENT
FACILITIES DEVELOPMENT DIVISION**

**APPLICATION FOR OSHPD PREAPPROVAL
OF MANUFACTURER'S CERTIFICATION (OPM)**

| | |
|-----------------|-------------|
| OFFICE USE ONLY | |
| APPLICATION #: | OPM-0180-13 |

OSHPD Preapproval of Manufacturer's Certification (OPM)

Type: New Renewal Update to Pre-CBC 2013 OPA Number: _____

Manufacturer Information

Manufacturer: Milestone AV Technologies

Manufacturer's Technical Representative: Michael Harrell

Mailing Address: 8401 Eagle Creek Parkway, Ste 700, Savage, MN. 55378

Telephone: (952) 225-6313 Email: Michael.harrell@milestone.com

Product Information

Product Name: LSMVU Monitor Wall Mount

Product Type: Computer/TV OPM-0180-13

Product Model Number: LSMVU BY: Jeffrey Y. Kikumoto

General Description: Low Profile TV Monitor Wall Mount DATE: 10/12/2015

Applicant Information

Applicant Company Name: EASE Co.

Contact Person: Jonathan Roberson, S.E.

Mailing Address: 5877 Pine Ave. Suite 210, Chino Hills, CA. 91709

Telephone: (909) 606-7622 Email: J.Roberson@EASECo.com

I hereby agree to reimburse the Office of Statewide Health Planning and Development review fees in accordance with the California Administrative Code, 2013.

Signature of Applicant: _____ Date: 9/28/15

Title: Principal Engineer Company Name: EASE Co.

"Access to Safe, Quality Healthcare Environments that Meet California's Diverse and Dynamic Needs"





**OFFICE OF STATEWIDE HEALTH PLANNING AND DEVELOPMENT
FACILITIES DEVELOPMENT DIVISION**

Registered Design Professional Preparing Engineering Recommendations

Company Name: EASE Co.

Name: Jonathan Roberson, S.E. California License Number: S4197

Mailing Address: 5877 Pine Ave. Suite 210, Chino Hills, CA. 91709

Telephone: 909-606-7667 Email: J.Roberson@EASECo.com

OSHPD Special Seismic Certification Preapproval (OSP)

Special Seismic Certification is preapproved under OSP-
(Separate application for OSP is required)

Special Seismic Certification is not preapproved

Certification Method(s)

Testing in accordance with: ICC-ES AC156 FM 1950-10

Other* (Please Specify): _____

*Use of test criteria other than those adopted by the California Building Standards Code, 2013 (CBSC 2013) for component supports and attachments are not permitted. For distribution system, interior partition wall, and suspended ceiling seismic bracings, test criteria other than those adopted in the CBSC 2013 may be used when approved by OSHPD prior to testing.

Analysis

Experience Data

Combination of Testing, Analysis, and/or Experience Data (Please Specify): _____

List of Attachments Supporting the Manufacturer's Certification

Test Report Drawings Calculations Manufacturer's Catalog

Other(s) (Please Specify): _____

OFFICE USE ONLY – OSHPD APPROVAL VALID FOR CBC 2013 ONLY

Signature: Date: 10-12-2015

Print Name: Jeffrey Kikumoto

Title: SSE

Condition of Approval (if applicable): _____

"Access to Safe, Quality Healthcare Environments that Meet California's Diverse and Dynamic Needs"





**EQUIPMENT ANCHORAGE
& SEISMIC ENGINEERING**

5877 Pine Ave, Ste. 210
Chino Hills, CA. 91709
Phn: (909) 606-7622

Office of Statewide Health Planning and Development
PREAPPROVAL OF MANUFACTURER'S CERTIFICATION
OPM-0180-13

THIS PREAPPROVAL CONFORMS TO THE 2013 CALIFORNIA BUILDING CODE

MANUFACTURER: **MILESTONE AV**
EQUIPMENT NAME: **LSMVU WALL MOUNT**

Sheet: 1 of 6
Date: 10/8/15

GENERAL NOTES

1. THIS OSHPD PREAPPROVAL OF MANUFACTURER'S CERTIFICATION (OPM) IS BASED ON THE 2013 CBC. THE DEMANDS (DESIGN FORCES) FOR USE WITH THIS OPM SHALL BE BASED ON THE 2013 CBC
2. THIS DOCUMENT MAY ONLY BE USED WITH THE EXPRESS WRITTEN CONSENT OF THE MANUFACTURER LISTED ABOVE FOR THE SPECIFIC PROJECT SITE AND INSTALLATION LOCATION. THIS DOCUMENT IS INVALID WITHOUT SUCH CONSENT.
3. THIS PREAPPROVAL CONFORMS TO THE 2013 CALIFORNIA BUILDING CODE WHERE S_{ds} IS NOT GREATER THAN 1.25, 220 SEE DETAIL FOR APPLICABILITY
4. FORCES PER ASCE 7-10 SECTION 13.3.1, EQUATIONS 13.3-1, 13.3-2 & 13.3-3,
WHERE $S_{ds} = 1.25$, $a_p = 2.5$, $I_p = 1.5$, $R_p = 2.5$, $z/h < 1$ SEE FOLLOWING SHEETS FOR Ω_0
WHERE $S_{ds} = 2.20$, $a_p = 2.5$, $I_p = 1.5$, $R_p = 2.5$, $z/h < 1$ SEE FOLLOWING SHEETS FOR Ω_0 AT CONCRETE WALL
5. THIS PREAPPROVAL COVERS ONLY THE SUPPORTS AND ATTACHMENTS OF THE EQUIPMENT TO THE STRUCTURE.
6. ALL DESIGN FORCES SHOWN ON THE DRAWINGS ARE FACTORED LOADS THAT SHALL BE USED FOR STRENGTH DESIGN.
7. SHEET METAL SCREWS SHALL BE TEKS SCREWS BY ITW BUILDEX (ICC ESR-1976).
8. **RESPONSIBILITIES OF THE STRUCTURAL ENGINEER OF RECORD OF THE BUILDING**
 - A. PROVIDE SUPPORTING STRUCTURE TO SUPPORT WEIGHTS AND FORCES SHOWN IN ADDITION TO ALL OTHER LOADS.
 - B. VERIFY THAT THE INSTALLATION IS IN CONFORMANCE WITH THE 2013 CBC AND WITH THE DETAILS, MATERIAL AND GAGE OF THE UNIT WHERE ATTACHMENTS ARE MADE AGREE WITH THE INFORMATION SHOWN ON THE PREAPPROVAL DOCUMENTS.
 - C. VERIFY THAT PROJECT SPECIFIC VALUES OF S_{ds} & z/h RESULT IN SEISMIC FORCES (E_h , E_v) THAT DO NOT EXCEED THE VALUES ON THE DETAILS.
 - D. VERIFY THAT THE CONCRETE WALL TO WHICH THE EQUIPMENT IS ANCHORED MEETS THE REQUIREMENTS OF THE APPLICABLE ICC ESR.
 - E. VERIFY THAT THE ANCHORS ARE AN ADEQUATE DISTANCE FROM ANY WALL EDGES OR OPENINGS (SEE TYPICAL DETAIL ON SHEET 2).
 - F. VERIFY THAT ALL NEW OR EXISTING ANCHORS ARE AN ADEQUATE DISTANCE FROM THE UNIT ATTACHMENTS AND CHECK FOR INTERACTION WHERE OTHER ANCHORS ARE WITHIN 18" OR $6h_{ef}$ FROM THIS UNIT'S ANCHORS.

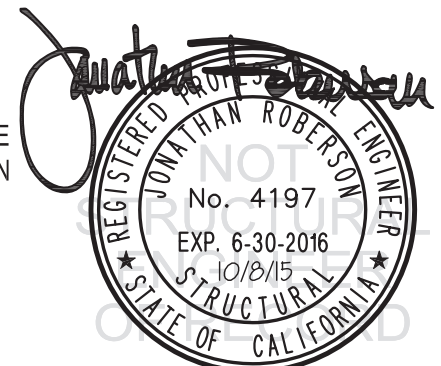

MILESTONE AV

DES. **J. ROBERSON**

SHEET

2

LSMVU WALL MOUNT

JOB NO. **11-1368**

DATE **10/8/15**

OF **6** SHEETS

9. SCREW ANCHORS:

- A. ATTACHMENT IS TO BE MADE WITH THE ANCHORS LISTED BELOW AND INSTALLED AS DESCRIBED IN THE CORRESPONDING ICC REPORT.

| Anchor Diameter | Concrete Type | Min. f'c (psi) | Anchor Type | ICC Report No. | Min. Embed. | Min. Spacing | Min. Edge Dist. | Min. Conc. Thickness | Torque Test | Direct Tension Test |
|-----------------|---------------|----------------|----------------|----------------|-------------|--------------|-----------------|----------------------|-------------|---------------------|
| 1/4" | Normal Weight | 3000 | Hilti Kwik HUS | ESR-3027 | 1.92" | 2.5" | 12" | 6" | N/A | 779 |

- B. THIS PREAPPROVAL ALLOWS FOR UP TO A MAXIMUM OF 2 ADJACENT CONCRETE WALL EDGES, 12" AWAY MINIMUM (i.e. - CORNER). SEE ADJACENT DETAIL FOR ADDITIONAL MINIMUM ALLOWABLE CONCRETE EDGE DISTANCES.

- C. TESTING OF CONCRETE SCREW ANCHORS PER 2013 CBC, 1913A.7: TESTING SHALL BE DONE IN THE PRESENCE OF THE SPECIAL INSPECTOR AND A REPORT OF THE TEST RESULTS SHALL BE SUBMITTED TO OSHPD

(i) AFTER AT LEAST 24 HOURS HAVE ELAPSED SINCE INSTALLATION, DIRECT PULL TENSION TEST AT LEAST 50% OF THE ANCHORS.

(ii) ACCEPTANCE CRITERIA:

- DIRECT TENSION TEST: THE ANCHOR SHOULD HAVE NO OBSERVABLE MOVEMENT AT THE TEST LOAD. A PRACTICAL WAY TO DETERMINE OBSERVABLE MOVEMENT IS THAT THE WASHER BECOMES LOOSE.

(iii) IF ANY ANCHOR FAILS, TEST ALL ANCHORS.

- D. AVOID DAMAGING EXISTING STEEL REINFORCING IN CONCRETE WALL WHEN INSTALLING CONCRETE SCREW ANCHORS

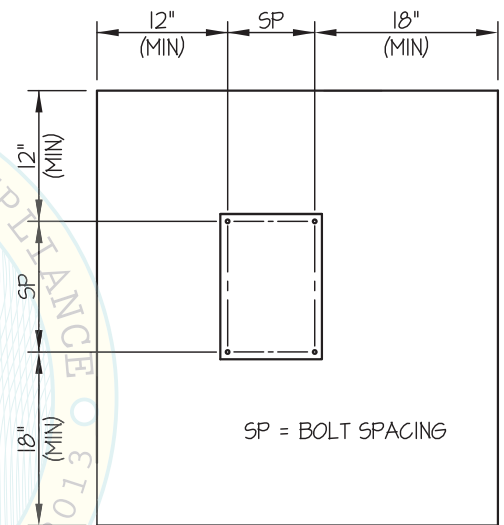

TYPICAL CONCRETE EDGE DETAIL

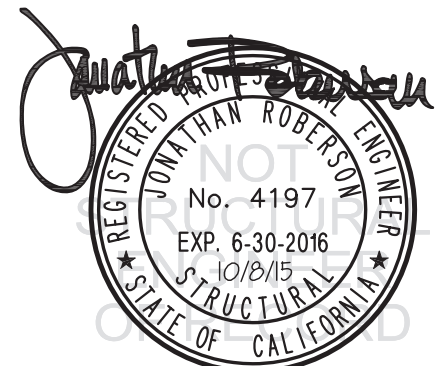

MILESTONE AV

DES. **J. ROBERSON**

SHEET

3

LSMVU WALL MOUNT

JOB NO. **11-1368**

DATE **10/8/15**

OF **6** SHEETS

SEISMIC SUPPORTS & ATTACHMENTS

WALL MOUNTED

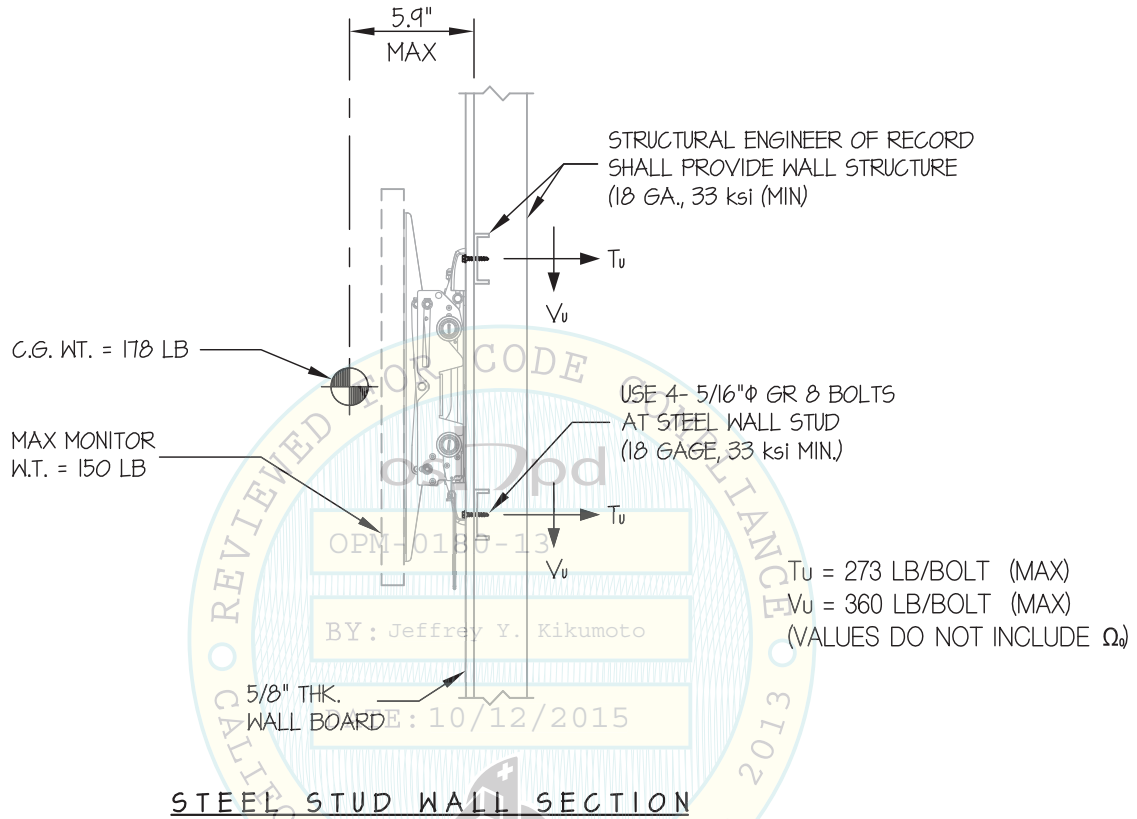

NOTES:

1. **FORCES ARE DETERMINED PER 2013 CALIFORNIA BUILDING CODE AND ASCE 7-10.**

STRENGTH DESIGN IS USED. ($S_d s = 2.20$, $a_p = 2.5$, $I_p = 1.5$, $R_p = 2.5$, $z/h \leq 1$)

HORIZONTAL FORCE (E_h) = $3.96 W_p$

VERTICAL FORCE (E_v) = $0.44 W_p$

2. CENTER OF GRAVITY (C.G.) AND WEIGHT ARE THE GOVERNING PARAMETERS FOR DESIGN. THIS PREAPPROVAL ENCOMPASSES ALL WEIGHTS UP TO THE MAXIMUM WEIGHT SHOWN.

3. STRUCTURAL ENGINEER OF RECORD FOR THE BUILDING SHALL PROVIDE SUPPORT STRUCTURE DESIGNED TO SUPPORT WEIGHTS AND FORCES SHOWN IN COMBINATION WITH ALL OTHER LOADS THAT MAY BE PRESENT.

4. SEE GENERAL NOTES; SHEETS 1 AND 2.

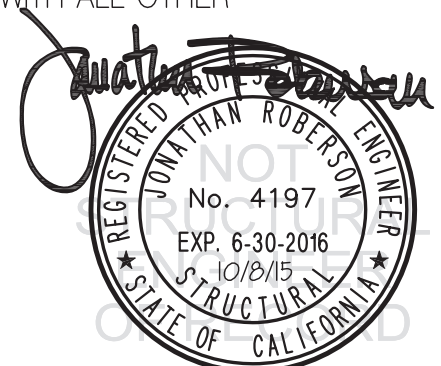

MILESTONE AV

LSMVU WALL MOUNT

DES. **J. ROBERSON**

JOB NO. **11-1368**

DATE **10/8/15**

SHEET

4

OF **6** SHEETS

SEISMIC SUPPORTS & ATTACHMENTS

WALL MOUNTED

STRUCTURAL ENGINEER OF RECORD
SHALL PROVIDE WALL STRUCTURE
(18 GA., 33 ksi (MIN))

UNIT BACKING
(12 GA, ASTM 1008 CS TYPE B
OR ASTM A1011 CS TYPE B,
F_y = 30 KSI MIN)

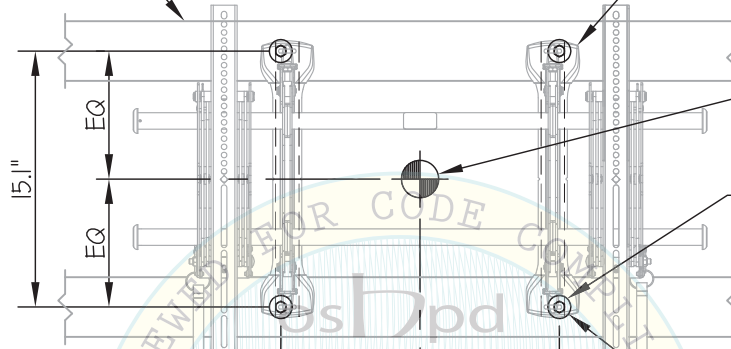

C.G. WT. = 178 LB
(Z = 5.9")

BOLTS TO BE SLID TO
OUTER ENDS OF SLOTS

USE 4- 5/16"φ GR 8 BOLTS
AT STEEL WALL STUD
(18 GAGE, 33 ksi MIN.)

FRONT ELEVATION

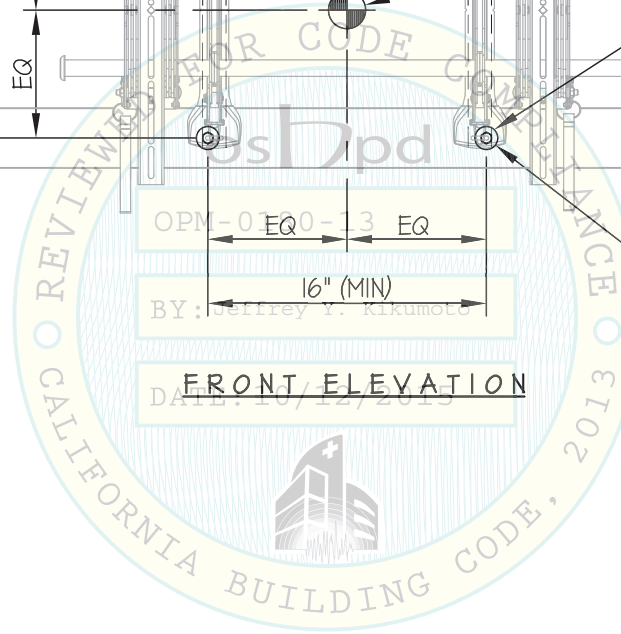

Jonathan Roberson
REGISTERED PROFESSIONAL ENGINEER
No. 4197
EXP. 6-30-2016
10/8/15
STRUCTURAL
STATE OF CALIFORNIA

MILESTONE AV

DES. **J. ROBERSON**

SHEET

5

LSMVU WALL MOUNT

JOB NO. **11-1368**

DATE **10/8/15**

OF **6** SHEETS

SEISMIC SUPPORTS & ATTACHMENTS

AT CONCRETE WALL

WALL MOUNTED

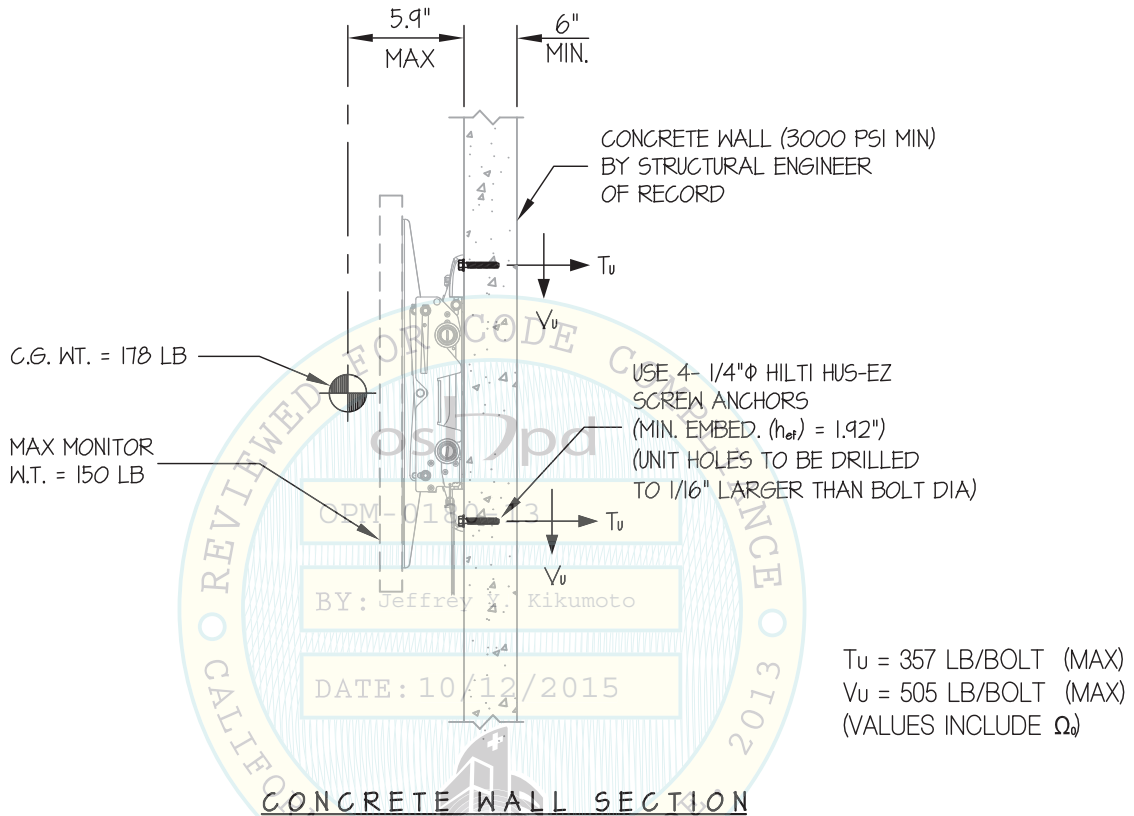

NOTES:

- FORCES ARE DETERMINED PER 2013 CALIFORNIA BUILDING CODE AND ASCE 7-10.**
STRENGTH DESIGN IS USED. ($S_{Ds} = 1.25$, $a_p = 2.5$, $l_p = 15$, $\Omega_o = 2.5$, $R_p = 2.5$, $z/h \leq 1$)
HORIZONTAL FORCE (E_h) = $2.25 W_p$
HORIZONTAL FORCE (E_{mh}) = $5.625 W_p$ (FOR CONCRETE ANCHORAGE)
VERTICAL FORCE (E_v) = $0.25 W_p$
- CENTER OF GRAVITY (C.G.) AND WEIGHT ARE THE GOVERNING PARAMETERS FOR DESIGN. THIS PREAPPROVAL ENCOMPASSES ALL WEIGHTS UP TO THE MAXIMUM WEIGHT SHOWN.
- STRUCTURAL ENGINEER OF RECORD FOR THE BUILDING SHALL PROVIDE SUPPORT STRUCTURE DESIGNED TO SUPPORT WEIGHTS AND FORCES SHOWN IN COMBINATION WITH ALL OTHER LOADS THAT MAY BE PRESENT.
- SEE GENERAL NOTES: SHEETS 1 AND 2.



MILESTONE AV

DES. **J. ROBERSON**

SHEET

6

LSMVU WALL MOUNT

JOB NO. **11-1368**

DATE **10/8/15**

OF **6** SHEETS

SEISMIC SUPPORTS & ATTACHMENTS

AT CONCRETE WALL

WALL MOUNTED

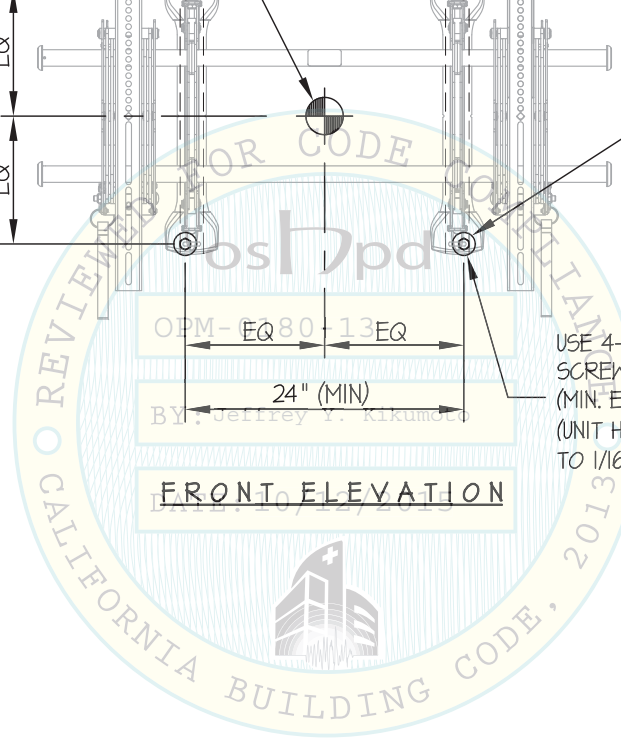
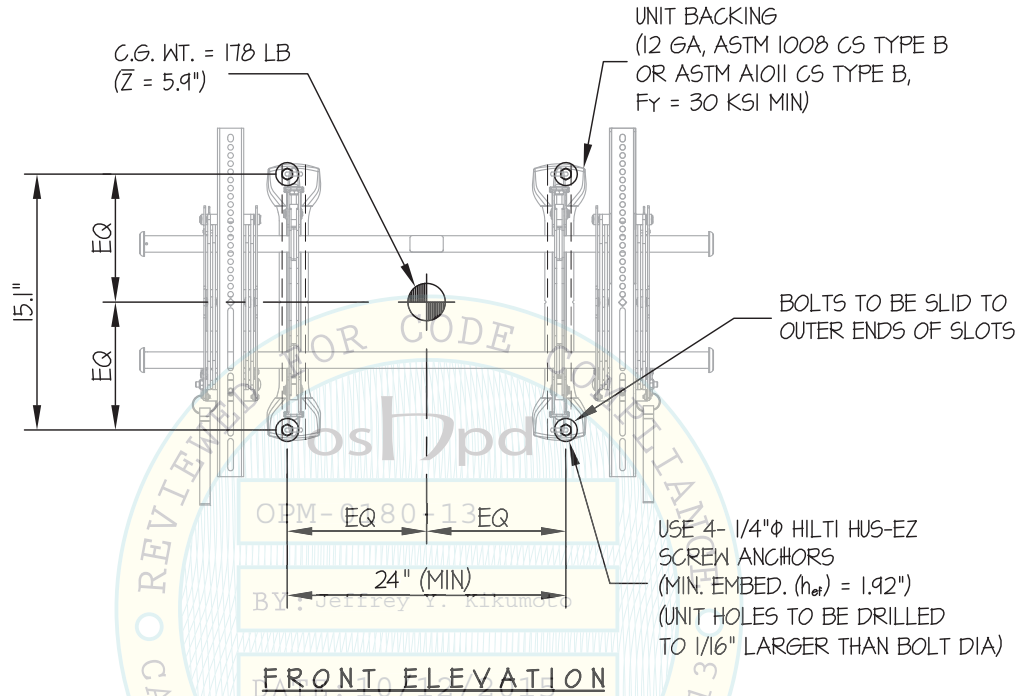

Jonathan Roberson

REGISTERED PROFESSIONAL ENGINEER
No. 4197
EXP. 6-30-2016
10/8/15
STRUCTURAL
STATE OF CALIFORNIA