



OFFICE OF STATEWIDE HEALTH PLANNING AND DEVELOPMENT
FACILITIES DEVELOPMENT DIVISION

APPLICATION FOR OSHPD PREAPPROVAL
OF MANUFACTURER'S CERTIFICATION (OPM)

OFFICE USE ONLY
APPLICATION #: OPM-0238-13

OSHPD Preapproval of Manufacturer's Certification (OPM)

Type: [X] New [] Renewal [] Update to Pre-CBC 2013 OPA Number:

Manufacturer Information

Manufacturer: Haworth
Manufacturer's Technical Representative: Jamison Burchfield
Mailing Address: One Haworth Center, Holland MI 49423
Telephone: 616.393.4227 Email: Jamison.burchfield@haworth.com

Product Information

Product Name: ENCLOSE Partition Walls
Product Type: Solid Panel
Product Model Number:
General Description: The ENCLOSE systems are non-bearing interior partition walls.

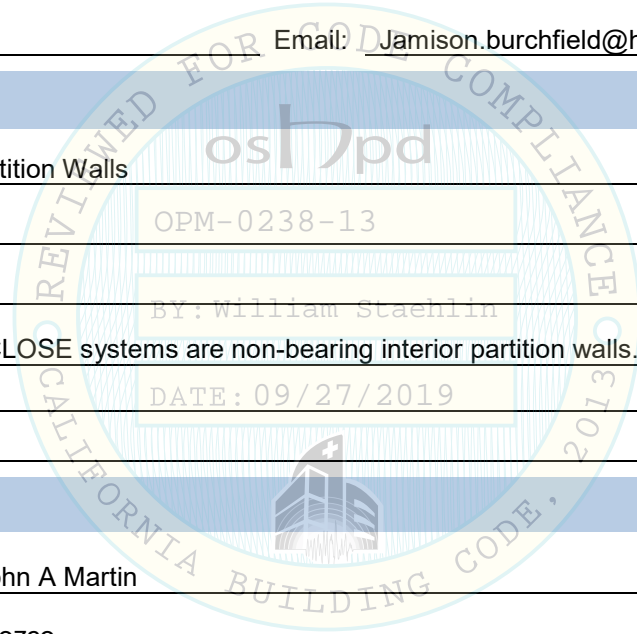

Applicant Information

Applicant Company Name: John A Martin
Contact Person: Gregory Orozco
Mailing Address: 950 S Grand Ave. 4th Floor
Telephone: 213.785.3187 Email: gorozco@johnmartin.com

I hereby agree to reimburse the Office of Statewide Health Planning and Development review fees in accordance with the California Administrative Code, 2013.

Signature of Applicant: [Signature] Date: 6/12/2015
Title: Project Manager Company Name: John A Martin

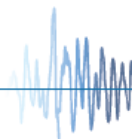



OFFICE OF STATEWIDE HEALTH PLANNING AND DEVELOPMENT
FACILITIES DEVELOPMENT DIVISION

Registered Design Professional Preparing Engineering Recommendations

Company Name: John A Martin
Name: Gregory Orozco California License Number: S4957
Mailing Address: 950 S Grand Ave. 4th Floor
Telephone: 213.785.3187 Email: gorozco@johnmartin.com

OSHPD Special Seismic Certification Preapproval (OSP)

- Special Seismic Certification is preapproved under OSP- (Separate application for OSP is required)
Special Seismic Certification is not preapproved

Certification Method(s)

- Testing in accordance with: ICC-ES AC156 FM 1950-10
Other* (Please Specify):

*Use of criteria other than those adopted by the California Building Standards Code, 2013 (CBSC 2013) for component supports and attachments are not permitted. For distribution system, interior partition wall, and suspended ceiling seismic bracings, test criteria other than those adopted in the CBSC 2013 may be used when approved by OSHPD prior to testing.

- Analysis
Experience Data
Combination of Testing, Analysis, and/or Experience Data (Please Specify):

List of Attachments Supporting the Manufacturer's Certification

- Test Report Drawings Calculations Manufacturer's Catalog
Other(s) (Please Specify):

OFFICE USE ONLY - OSHPD APPROVAL VALID FOR CBC 2013 ONLY

Signature: [Signature] Date: 9/27/2019
Print Name: William Staehlin
Title: SSE
Condition of Approval (if applicable):

"Access to Safe, Quality Healthcare Environments that Meet California's

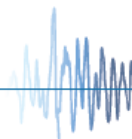

GENERAL

- THIS OSHPD PREAPPROVAL OF MANUFACTURER'S CERTIFICATION (OPM) IS BASED ON THE CBC 2013. THE DEMAND (DESIGN FORCES) FOR USE WITH THIS OPM SHALL BE BASED ON THE CBC 2013.
- THIS OPM IS EXCLUSIVELY FOR INSTALLING THE HAWORTH ENCLOSE™ WALL SYSTEM

ENCLOSE WALL			
MAXIMUM SDS VALUES FOR VARIOUS WALL HEIGHTS & z/h:			
z/h	12'	10'	8'
1.00	1.97	2.36	2.50
0.90	2.11	2.50	2.50
0.80	2.27	2.50	2.50
0.70	2.46	2.50	2.50
0.60	2.50	2.50	2.50
0.50	2.50	2.50	2.50
0.40	2.50	2.50	2.50
0.30	2.50	2.50	2.50
0.20	2.50	2.50	2.50
0.10	2.50	2.50	2.50
0.00	2.50	2.50	2.50

ENCLOSE WALL 16"x16" SHELF ON ONE SIDE (CONTENT+FURNITURE WEIGHT = 38pcf)			
MAXIMUM SDS VALUES FOR VARIOUS WALL HEIGHTS & z/h:			
z/h	12'	10'	8'
1.00	1.63	1.85	1.71
0.90	1.75	1.99	1.84
0.80	1.88	2.14	1.98
0.70	2.04	2.32	2.14
0.60	2.23	2.50	2.34
0.50	2.45	2.50	2.50
0.40	2.50	2.50	2.50
0.30	2.50	2.50	2.50
0.20	2.50	2.50	2.50
0.10	2.50	2.50	2.50
0.00	2.50	2.50	2.50

- THE CONTRACTOR SHALL VERIFY ALL DIMENSIONS PRIOR TO CONSTRUCTION. THE OWNER'S REPRESENTATIVE SHALL BE NOTIFIED OF ANY DISCREPANCIES OR INCONSISTENCIES.
- INFORMATION SHOWN ON THE DRAWINGS RELATED TO EXISTING CONDITIONS REPRESENTS THE PRESENT KNOWLEDGE, BUT WITHOUT GUARANTEE OF ACCURACY. REPORT CONDITIONS THAT CONFLICT WITH THE CONTRACT DOCUMENTS TO THE OWNER'S REPRESENTATIVE. DO NOT DEVIATE FROM THE CONTRACT DOCUMENTS WITHOUT WRITTEN DIRECTION FROM THE OWNER'S REPRESENTATIVE.
- DIMENSIONS SHALL TAKE PRECEDENCE OVER SCALED DRAWINGS. DRAWINGS SHALL NOT BE SCALED.
- TYPICAL DETAILS AND GENERAL NOTES APPLY TO ALL PARTS OF THE WORK, EXCEPT WHERE SPECIFICALLY DETAILED OR UNLESS NOTED OTHERWISE. THESE DETAILS ARE NOT SPECIFICALLY REFERENCED WHERE THEY OCCUR.
- NOTES AND DETAILS ON DRAWINGS SHALL TAKE PRECEDENCE OVER GENERAL NOTES AND TYPICAL DETAILS. WHERE NOTES AND DETAILS ON DRAWINGS AND THESE GENERAL NOTES AND TYPICAL DETAILS ARE IN CONFLICT WITH THE PROJECT SPECIFICATIONS THE MOST STRINGENT SHALL APPLY. CONDITIONS NOT SPECIFICALLY SHOWN SHALL BE CONSTRUCTED AS SHOWN FOR SIMILAR WORK.
- ALL WORK SHALL CONFORM TO THE STANDARDS OF THE FOLLOWING:
CALIFORNIA BUILDING CODE, 2013 EDITION
ASCE 7-10 INCLUDING SUPPLEMENTS 1 AND 2.

AND ANY OTHER REGULATING AGENCIES WHICH HAVE AUTHORITY OVER ANY PORTION OF THE WORK, INCLUDING BUT NOT LIMITED TO CAL/OSHA, DIVISION OF OCCUPATIONAL SAFETY AND HEALTH, AND THOSE CODES AND STANDARDS LISTED IN THE CONTRACT DOCUMENTS.
- CODES, AND STANDARDS NOTED IN THE CONTRACT DOCUMENTS SHALL BE OF THE LATEST APPROVED ISSUE, INCLUDING SUPPLEMENTS, UNLESS OTHERWISE NOTED. MATERIAL SPECIFICATIONS SHALL COMPLY WITH ASTM REFERENCED STANDARDS LATEST EDITION.
- CONTRACTOR SHALL CAREFULLY REVIEW THE DRAWINGS TO IDENTIFY THE EXTENT OF THE SCOPE OF WORK. VISIT THE SITE TO RELATE THE SCOPE OF WORK TO EXISTING CONDITIONS AND DETERMINE THE EXTENT TO WHICH THOSE CONDITIONS AND PHYSICAL SURROUNDINGS WILL IMPACT THE WORK.
- SEISMIC DESIGN LOADS BASED ON 2013 CBC 1613A & ASCE 7-10 13.3, RISK CATEGORY IV, IMPORTANCE FACTOR $I_p = 1.5$, COMPONENT AMPLIFICATION/RESPONSE FACTOR $a_p = 1.0 / R_p = 2.5$, OVERSTRENGTH FACTOR $\Omega = 2.5$ (CONCRETE DESIGN ONLY), MAXIMUM ALLOWABLE S_{ds} AND z/h VALUES VARY SEE TABLES ABOVE.
- FOR PROJECTS WHERE THE S_{ds} AND z/h VALUES ARE GREATER THAN THE VALUES LISTED IN THE TABLES ABOVE CONTACT HAWORTH FOR AN ALTERNATIVE ENGINEERING SOLUTION.

MECHANICAL ANCHORS

- EXPANSION ANCHORS INTO CONCRETE: HILTI KB TZ GALVANIZED CARBON STEEL (ICC ESR-1917 CORRECTED MAY 2015) TO BE INSTALLED IN ACCORDANCE WITH ICC REPORT AND MANUFACTURER'S RECOMMENDATIONS. MAINTAIN FULL THREAD ENGAGEMENT FOR NUT AND WASHER.
- IF REINFORCEMENT IS ENCOUNTERED DURING DRILLING, ABANDON AND SHIFT THE HOLE LOCATION TO AVOID THE REINFORCEMENT. PROVIDE A MINIMUM OF 2 ANCHOR DIAMETERS OR 1 INCH, WHICHEVER IS LARGER, OF SOUND CONCRETE BETWEEN THE DOWEL AND THE ABANDONED HOLE. FILL THE ABANDONED HOLE WITH NON-SHRINK GROUT. NON-SHRINK GROUT SHALL HAVE A MINIMUM 28 DAY STRENGTH OF 6,000 PSI. USE "SIKA GROUT 212" OR "MASTERFLOW 928". IF THE ANCHOR OR DOWEL MAY NOT BE SHIFTED AS NOTED ABOVE, THE STRUCTURAL ENGINEER WILL DETERMINE A NEW LOCATION.
- ANCHORS SHALL BE PROOF-TESTED BY OWNER'S TESTING AND INSPECTION AGENCY OR TESTED IN THE PRESENCE OF THE SPECIAL INSPECTOR. A REPORT OF THE TEST RESULTS SHALL BE SUBMITTED TO OSHPD.
- TEST ANCHORS NO SOONER THAN 24 HOURS AFTER INSTALLATION.
- REACTION LOADS FROM TEST FIXTURES MAY BE APPLIED CLOSE TO THE ANCHOR BEING TESTED, PROVIDED THE ANCHOR IS NOT RESTRAINED FROM WITHDRAWING BY A BASE PLATE OR OTHER FIXTURE. IF RESTRAINT IS FOUND, LOOSEN AND SHIM OR REMOVE THE FIXTURE PRIOR TO TESTING.
- TEST 50% OF ANCHORS PER THE FOLLOWING METHOD AND IN ACCORDANCE WITH THE VALUES SHOWN IN THE TABLE:
A. TORQUE WRENCH METHOD: TEST ANCHORS TO THE TORQUE LOAD INDICATED IN THE TABLE WITHIN ONE-HALF TURN OF THE NUT.

EXPANSION ANCHOR EMBEDMENT DEPTH AND TEST LOAD		
ANCHOR DIAMETER	(h _{de}) MIN EMBED	ANCHORS IN CONCRETE
		TORQUE LOAD (FT-LBS)
1/2"	2"	40

- IF ANY ANCHOR FAILS TESTING, REPLACE ANCHOR AND TEST ALL ANCHORS OF THE SAME CATEGORY INSTALLED BY THE SAME TRADE NOT PREVIOUSLY TESTED UNTIL TWENTY (20) CONSECUTIVE TESTS PASS, THEN RESUME INITIAL TESTING FREQUENCY.

METAL STUDS

- PROVIDE LIGHT GAUGE FRAMING FORMED FROM STANDARD COMMERCIAL STEEL WITH A MINIMUM YIELD AT 33,000 PSI FOR GAUGES 18 AND LIGHTER AND 50,000 FOR GAUGES 16 AND HEAVIER. IN ADDITION, FRAMING SHALL COMPLY WITH ASTM A653, SS GRADE 33 & SS GRADE 50 CLASS 1 RESPECTIVELY, SECTION 2210A OF THE CALIFORNIA BUILDING CODE AND SPECIFICATIONS FOR THE DESIGN OF COLD-FORMED STEEL STRUCTURAL MEMBERS OF AISI, LATEST EDITION. LIGHT GAUGE FRAMING AND ITS INSTALLATION SHALL COMPLY WITH ICC REPORT NO. ESR-3064P REISSUED FEB 2015.
- PROVIDE UNPUNCHED TRACK WITH THICKNESS TO MATCH STUDS, UNLESS NOTED OTHERWISE, OF DIMENSIONS TO ENSURE PROPER FIT IF STUDS.
2 1/2" x 18. GA. TRACK (250T150-43) I_{xx} (MIN.) = 0.289 IN⁴
 S_{xx} (MIN.) = 0.217 IN³
2 1/2" x 18. GA. TRACK (250T200-43) I_{xx} (MIN.) = 0.366 IN⁴
 S_{xx} (MIN.) = 0.275 IN³
- CUT FRAMING COMPONENTS, SUCH AS BRACING, SQUARELY OR AT AN ANGLE TO FIT TIGHT AGAINST ABUTTING MEMBERS. HOLD MEMBERS FIRMLY IN POSITION UNTIL PROPERLY FASTENED.
- SPLICES IN ANY LIGHT GAUGE MEMBERS IS NOT ALLOWED.
- ALL METAL SCREW INDICATED ON THESE DRAWINGS ARE HILTI BRAND SELF-DRILLING/SELF-TAPPING STEEL SCREWS AS MANUFACTURED HILTI CORPORATION COMPLYING WITH ICC EVALUATION REPORT NO. ESR-2196.

INSPECTION / TESTING

- AN INDEPENDENT TESTING AGENCY AND SPECIAL INSPECTORS SHALL BE RETAINED BY THE OWNER TO PERFORM THE TESTS AND INSPECTION AS REQUIRED BY SECTION 1704A OF THE CALIFORNIA BUILDING CODE. THE CONTRACTOR SHALL PROVIDE ACCESS TO THE SPECIAL INSPECTOR TO THE SITE OR FABRICATION SHOPS AND SHALL FURNISH SAMPLES OF MATERIALS FOR TESTING AS REQUESTED BY THE TESTING AGENCY AND THE GOVERNING CODE.
- IF INITIAL TESTS OR INSPECTIONS MADE BY THE OWNER'S TESTING AGENCY REVEAL THAT ANY PORTION OF THE WORK DOES NOT COMPLY WITH THE CONTRACT DOCUMENTS, ADDITIONAL TESTS, INSPECTIONS, AND NECESSARY REPAIRS WILL BE MADE AT THE CONTRACTOR'S EXPENSE.
- PROVIDE PERIODIC SPECIAL INSPECTION FOR ALL HILTI KB-TZ, AS REQUIRED PER THE CHAPTER 17A OF THE CALIFORNIA BUILDING CODE AND ALL APPLICABLE AMENDMENTS:

WOOD FASTENERS

- WOOD SCREWS SHALL COMPLY WITH ANSI/ASME B18.6.1. PREDRILLED SCREW HOLES SHALL BE 2/3 DIAMETER. MINIMUM SCREW YIELD STRENGTH SHALL BE AS FOLLOWS:

SCREW NOMINAL DIAMETER	YIELD STRENGTH (FYB)
0.099" ≤ D ≤ 0.142"	100,000 PSI
0.142" ≤ D ≤ 0.177"	90,000 PSI
0.177" ≤ D ≤ 0.236"	80,000 PSI
0.236" ≤ D ≤ 0.273"	70,000 PSI

RESPONSIBILITIES OF THE STRUCTURAL ENGINEER OF RECORD (SEOR)

- VERIFY EXISTING SLABS, DECKS, JOISTS AND SOFFITS CAN RESIST LOADS IMPOSED BY NEW WALL AND BRACE CONNECTIONS IN ADDITION TO THEIR EXISTING LOADS.
- VERIFY CONCRETE COMPRESSIVE STRENGTH (f_c) COMPLIES WITH THE MINIMUM SHOWN IN THESE DRAWINGS.
- VERIFY EXISTING SLAB THICKNESS AND EDGE DISTANCES COMPLY WITH THE MINIMUM SHOWN IN THESE DRAWINGS.
- VERIFY THAT ALL EXISTING WOOD MEMBERS WHERE ATTACHMENTS ARE BEING MADE HAVE A SPECIFIC GRAVITY OF AT LEAST 0.50.

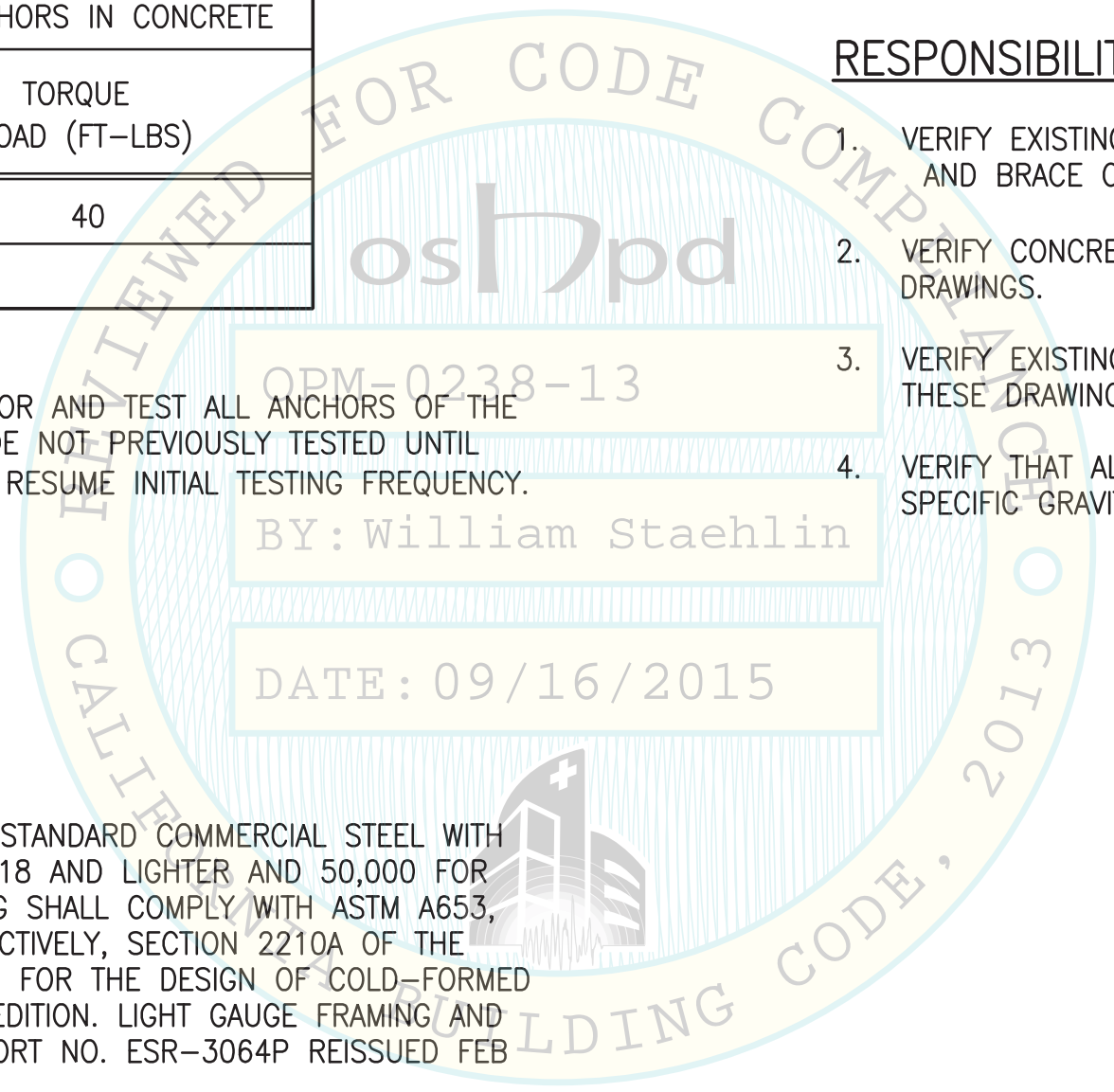

THE CONDITIONS GOVERNING USE OF THIS DOCUMENT are those set forth in the contract documents and shall remain the property of the Structural Engineer of Record (SEOR). No part thereof shall be copied, reproduced, or transmitted in any form or by any means, electronic or mechanical, including photocopying, recording, or by any information storage and retrieval system, without the written consent of the SEOR. The SEOR shall not be responsible for any damage or injury to persons or property resulting from the use of this document. The SEOR shall not be responsible for any damage or injury to persons or property resulting from the use of this document. The SEOR shall not be responsible for any damage or injury to persons or property resulting from the use of this document.

DESCRIPTION	
ISSUE DATE	
GENERAL NOTES	
PROJECT	HAWORTH OPM
PROJECT ADDRESS	XX XX

JOHN A. MARTIN & ASSOCIATES, INC.
STRUCTURAL ENGINEERS
980 S. GRAND AVENUE LOS ANGELES, CALIF. 90015

SHEET NUMBER	J13139-00	OWNER	JAMA	DATE	09-25-15
S-1					
OF					

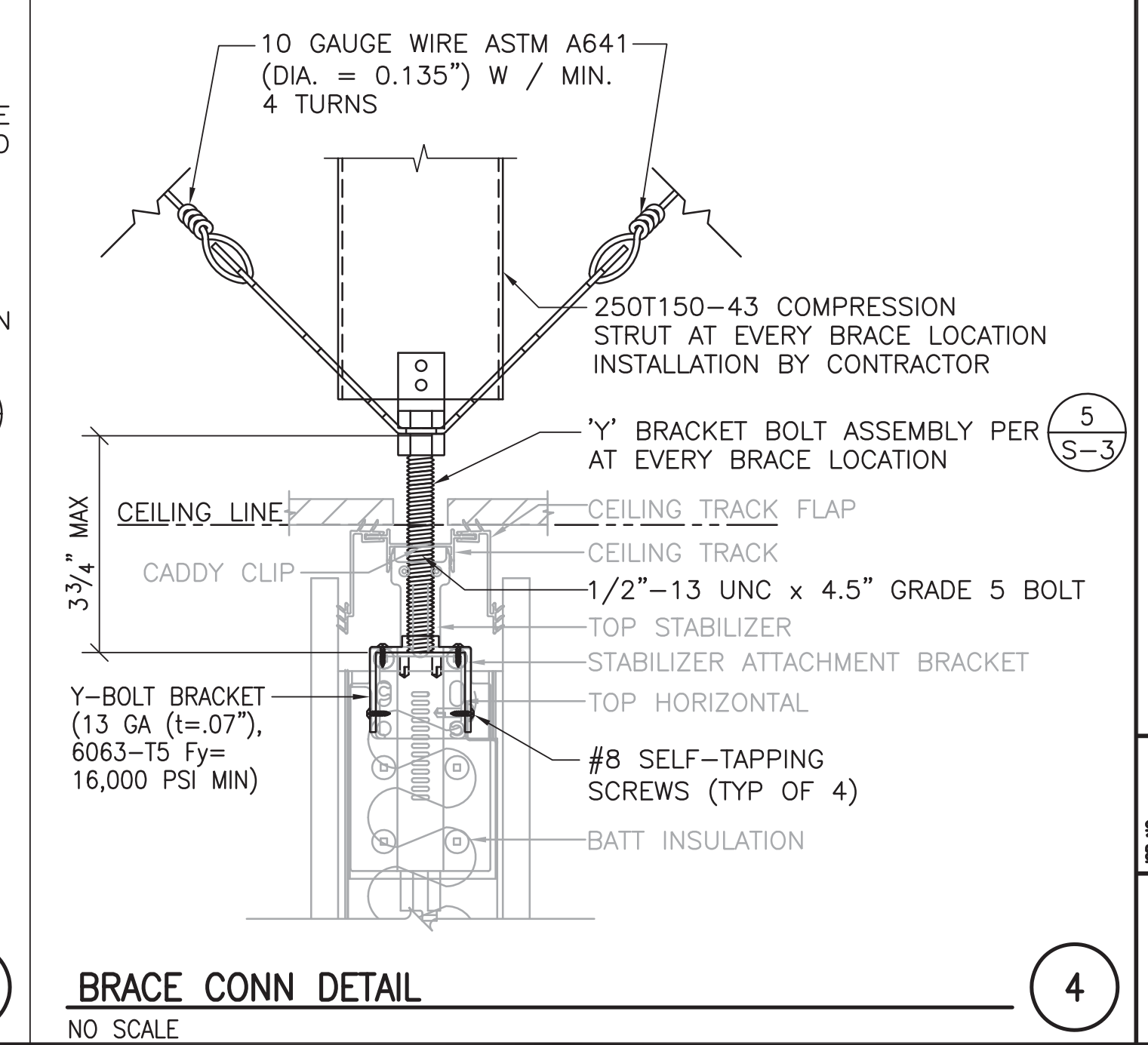
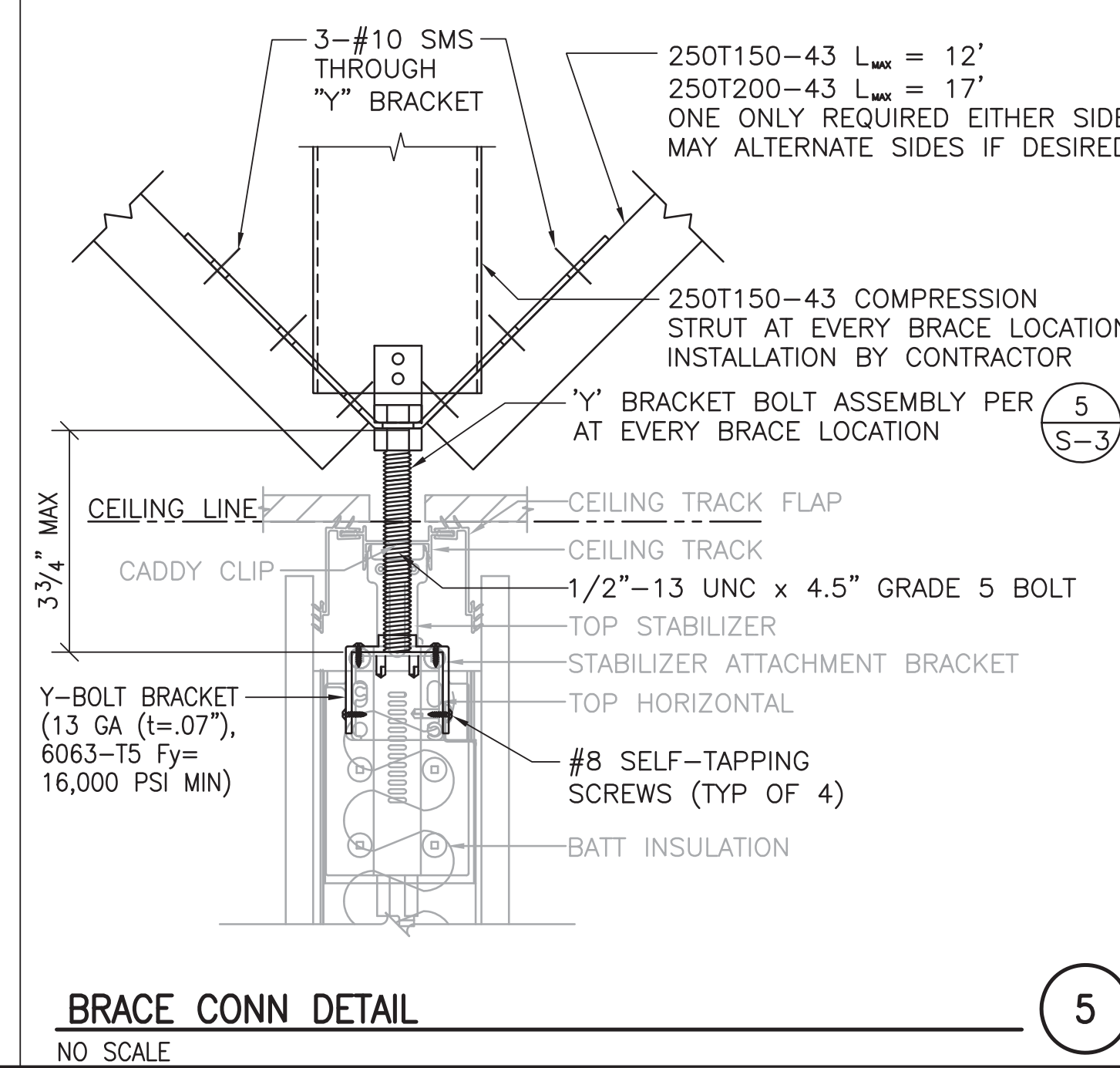
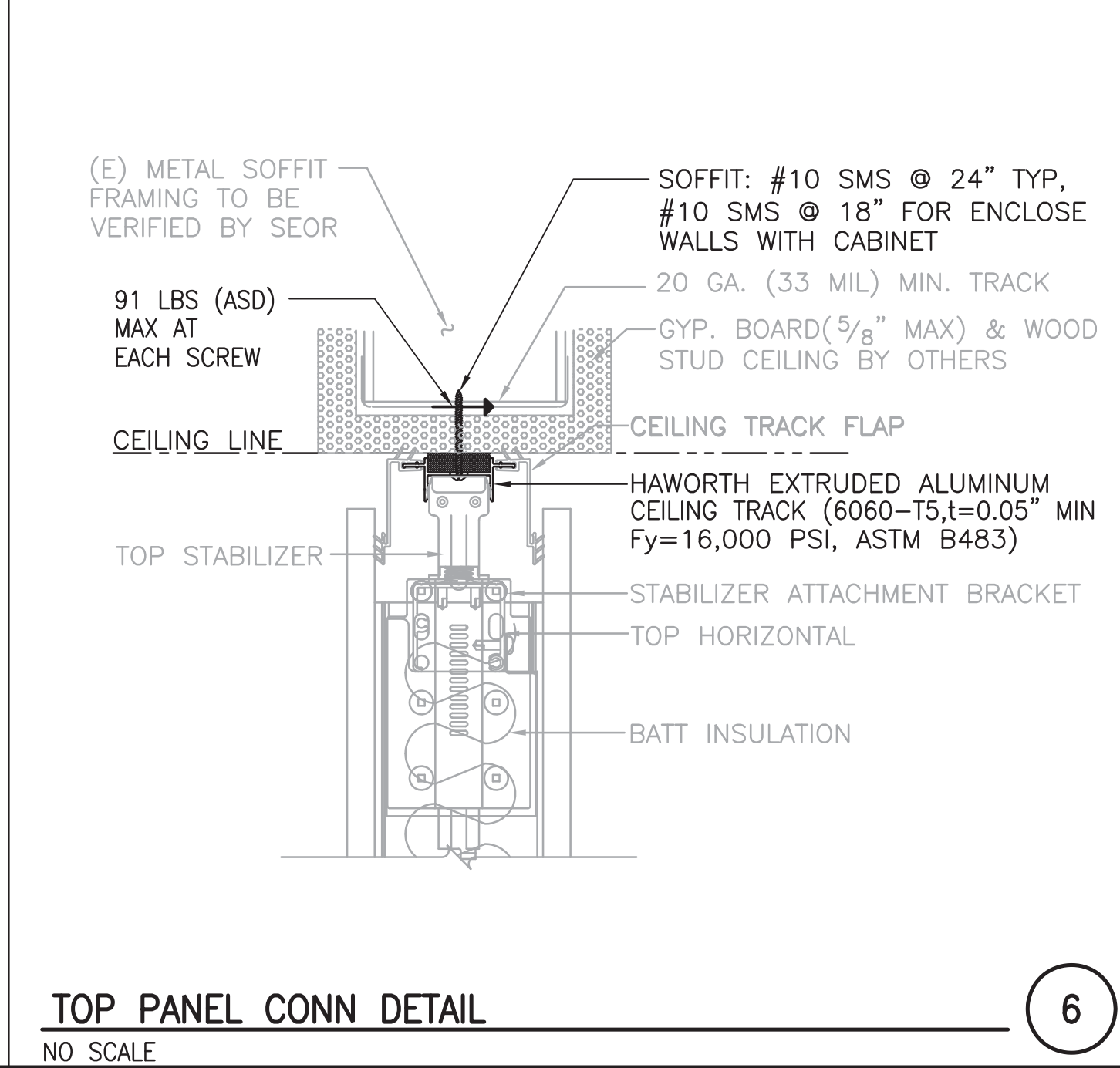
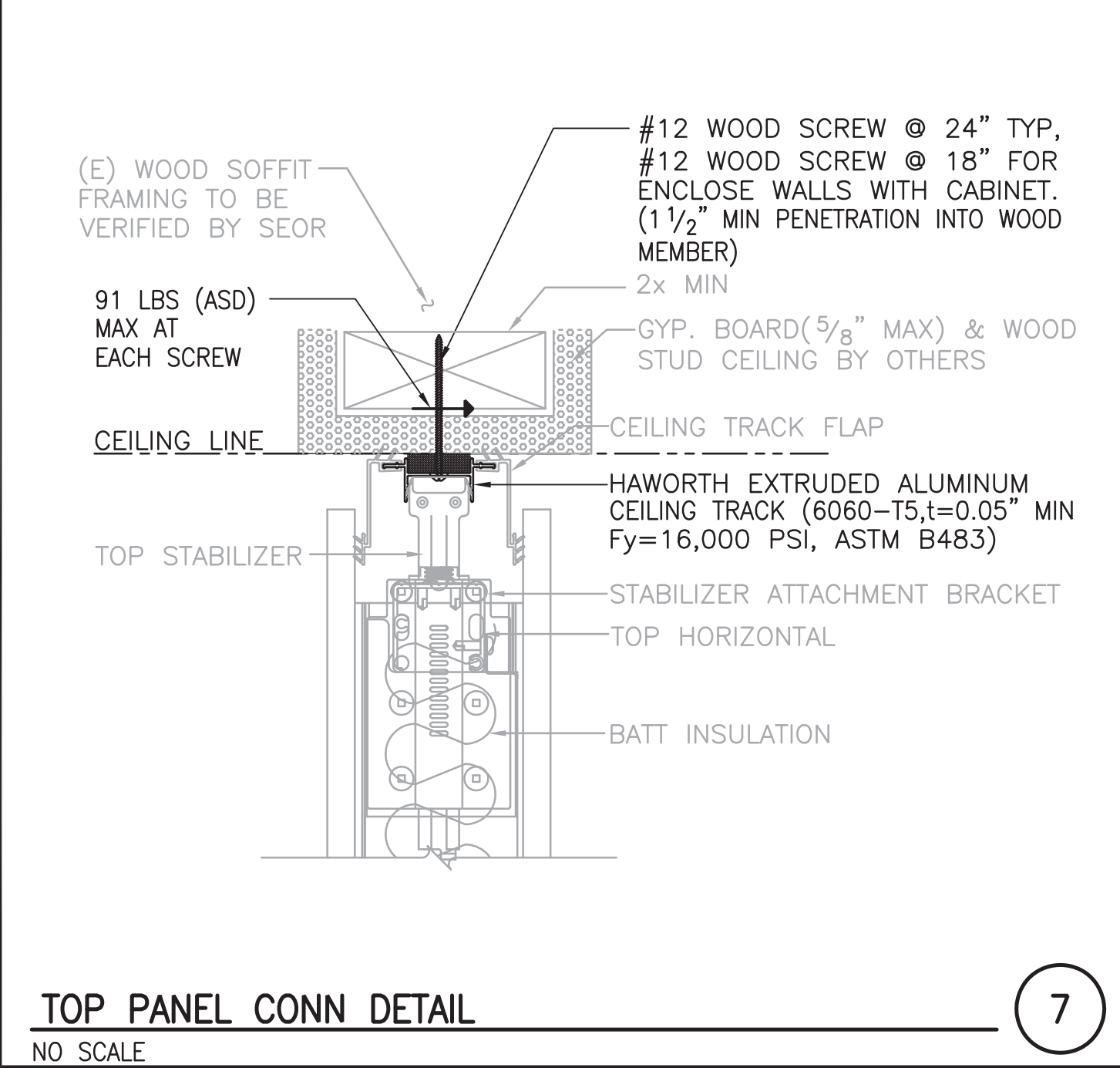
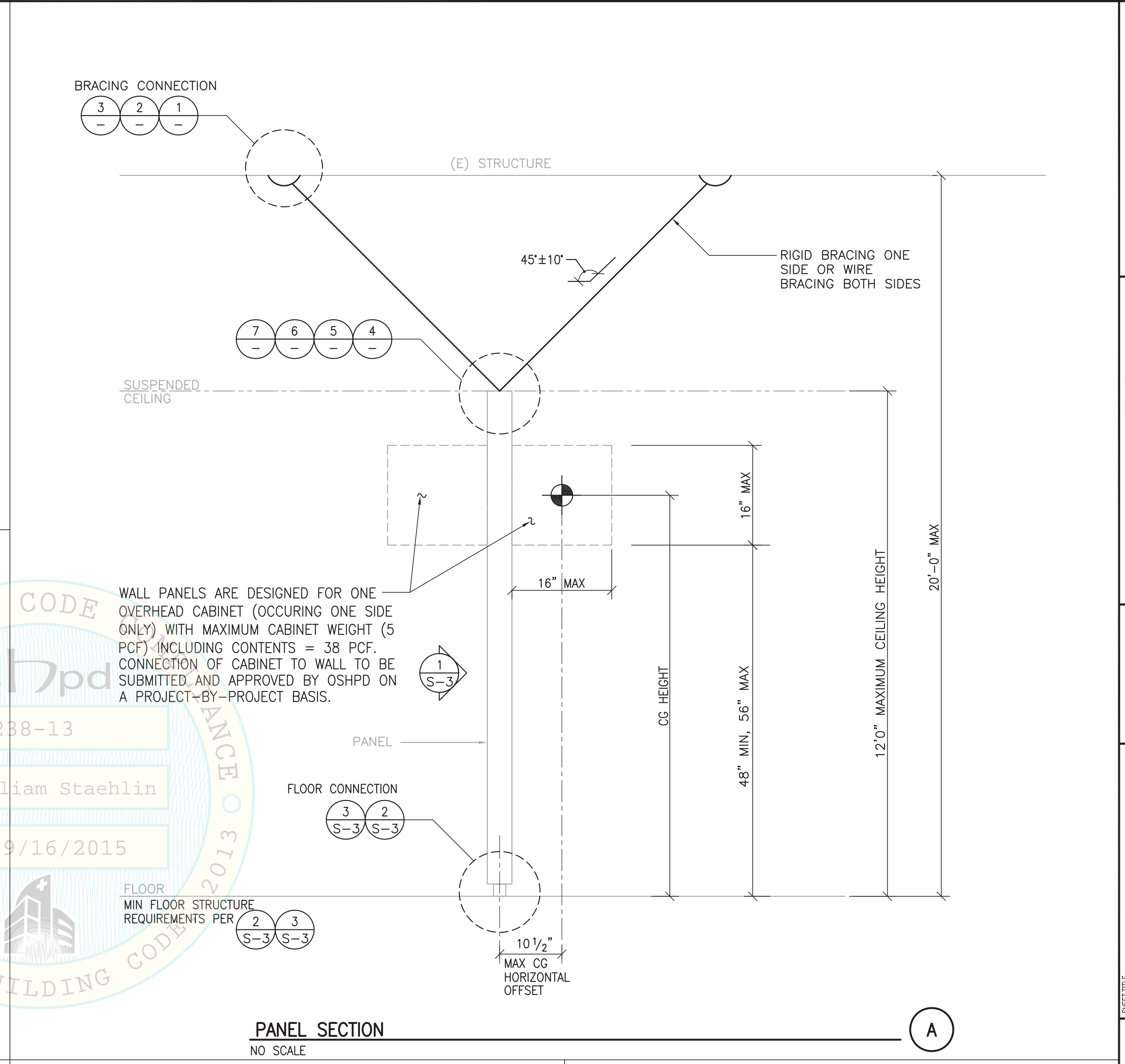
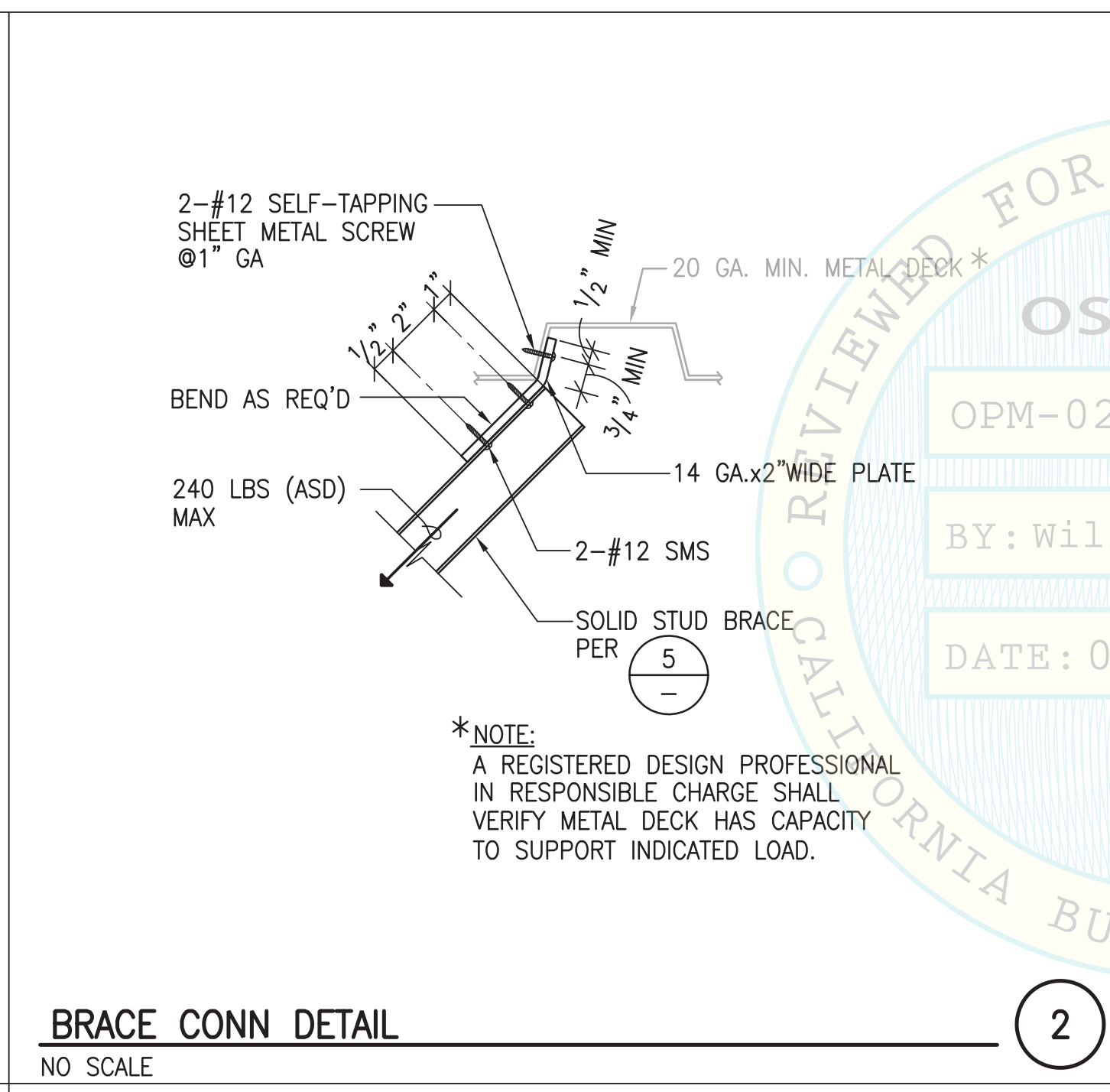
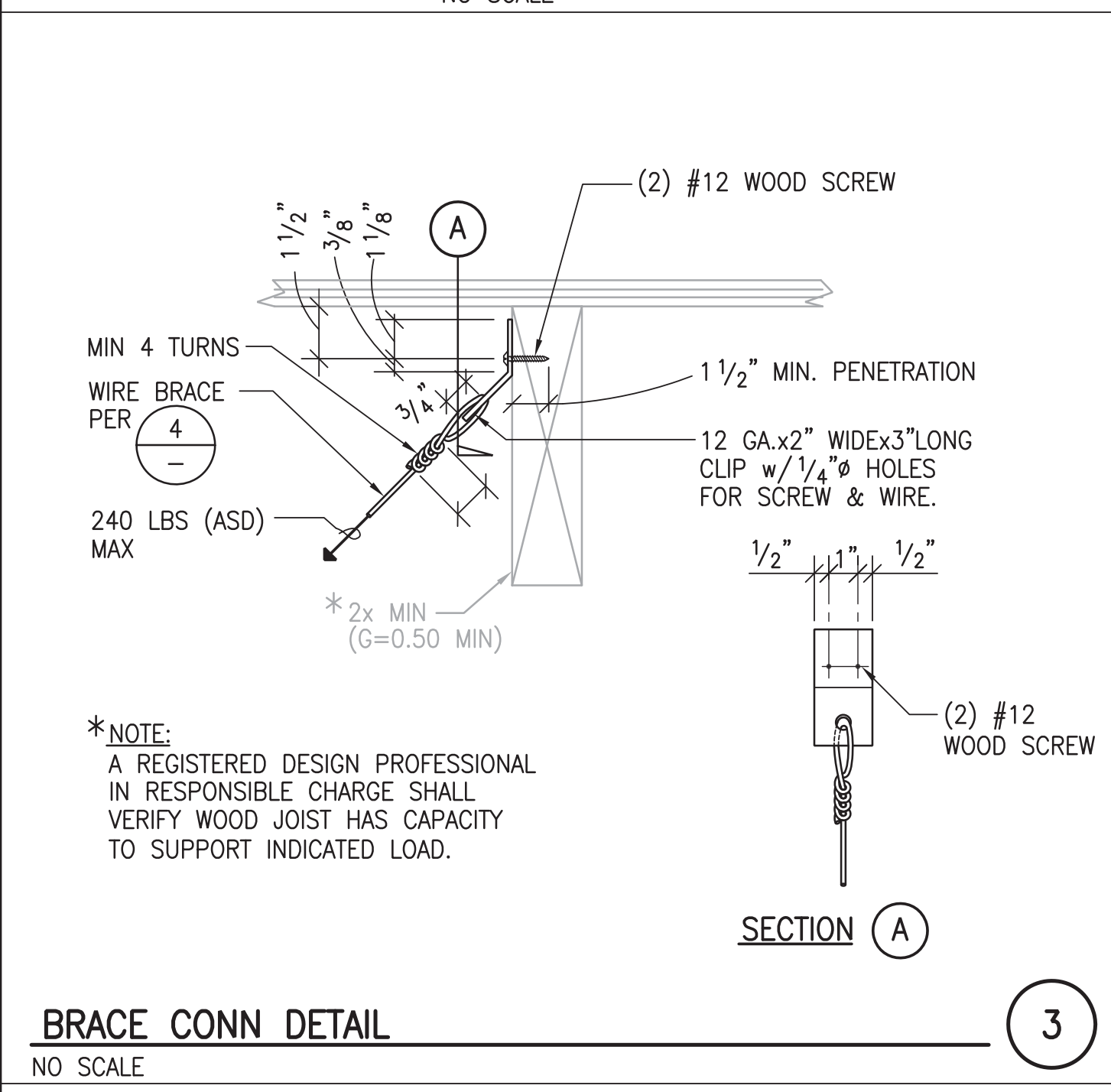
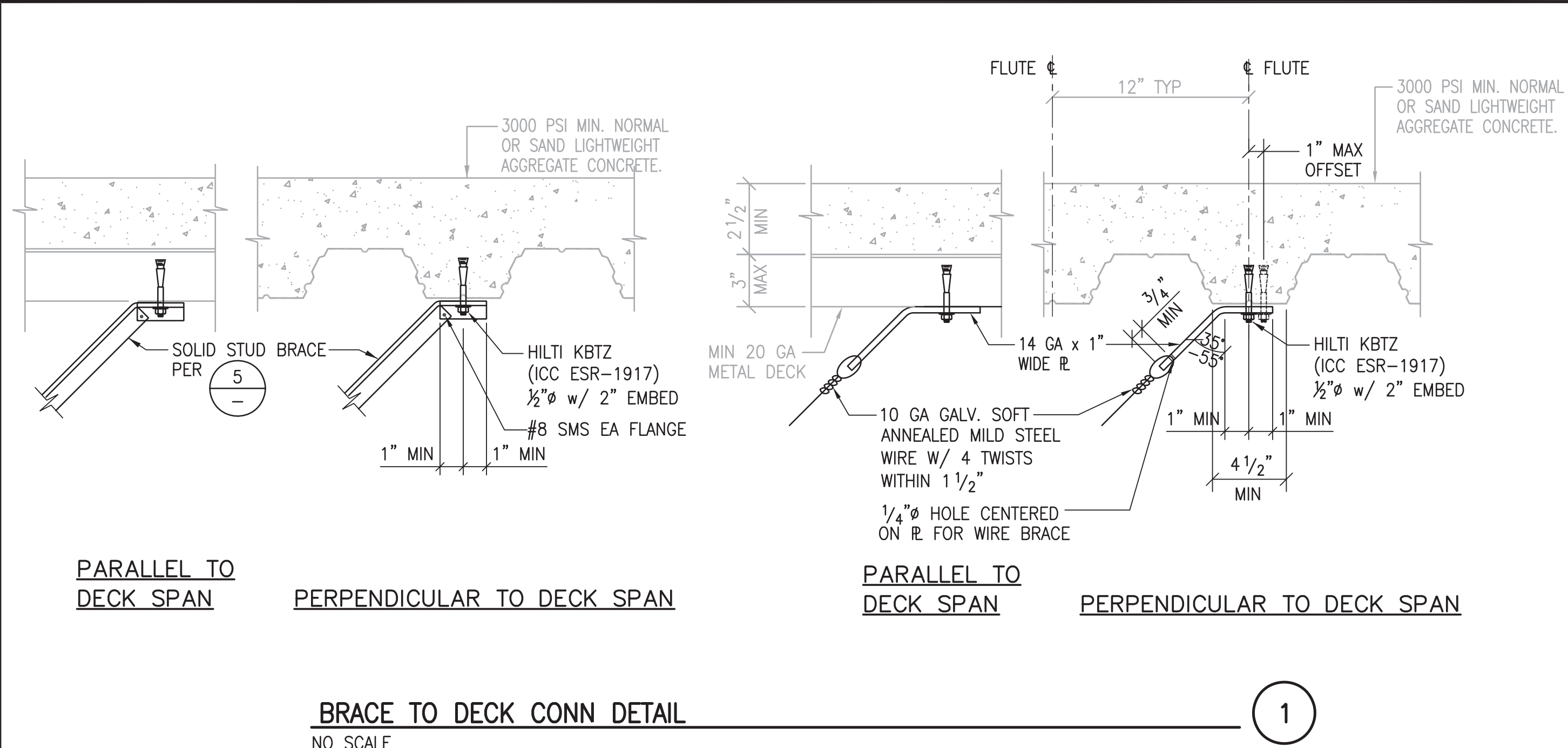

CONDITIONS GOVERNING USE OF THIS DOCUMENT:
The user of this document shall be responsible for verifying the accuracy of the information contained herein and for obtaining all necessary permits and approvals from the appropriate authorities. The user shall be held responsible for any and all consequences arising from the use of this document.

ISSUE	DATE	DESCRIPTION

REGISTERED PROFESSIONAL ENGINEER
No. 4957
STRUCTURAL
STATE OF CALIFORNIA

SECTIONS AND DETAILS
PROJECT: HAWORTH OPM
PROJECT XX
ADDRESS XX

HAWORTH & ASSOCIATES, INC.
STRUCTURAL ENGINEERS
980 S. GRAND AVENUE LOS ANGELES, CALIF. 90015

JOHN A. MARTIN & ASSOCIATES, INC.
STRUCTURAL ENGINEERS
980 S. GRAND AVENUE LOS ANGELES, CALIF. 90015

OWNER: JAMA
DATE: 08-25-15

SHEET NUMBER: J1318-00
OF SHEETS: S-2

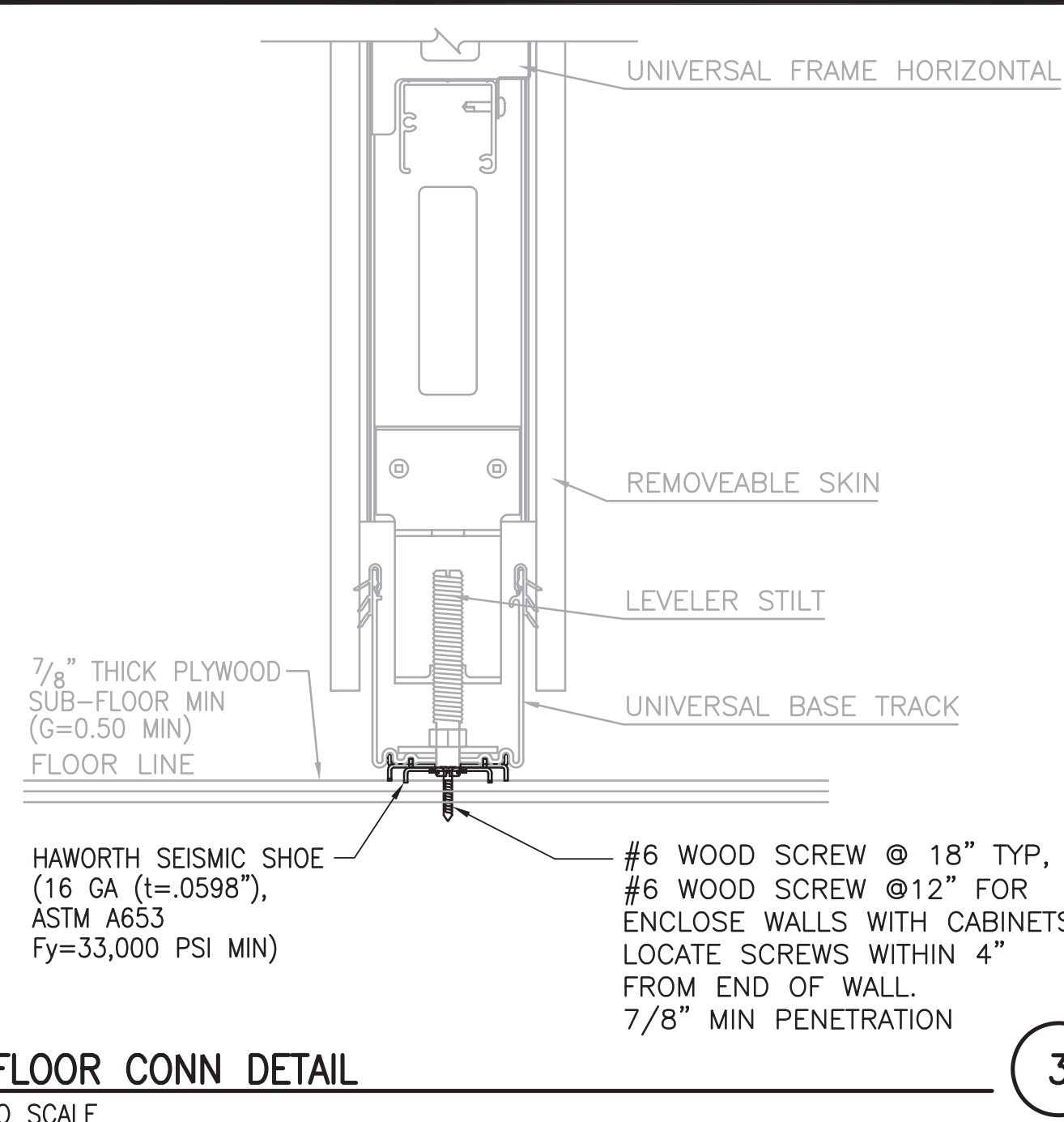

FLOOR CONN DETAIL
NO SCALE

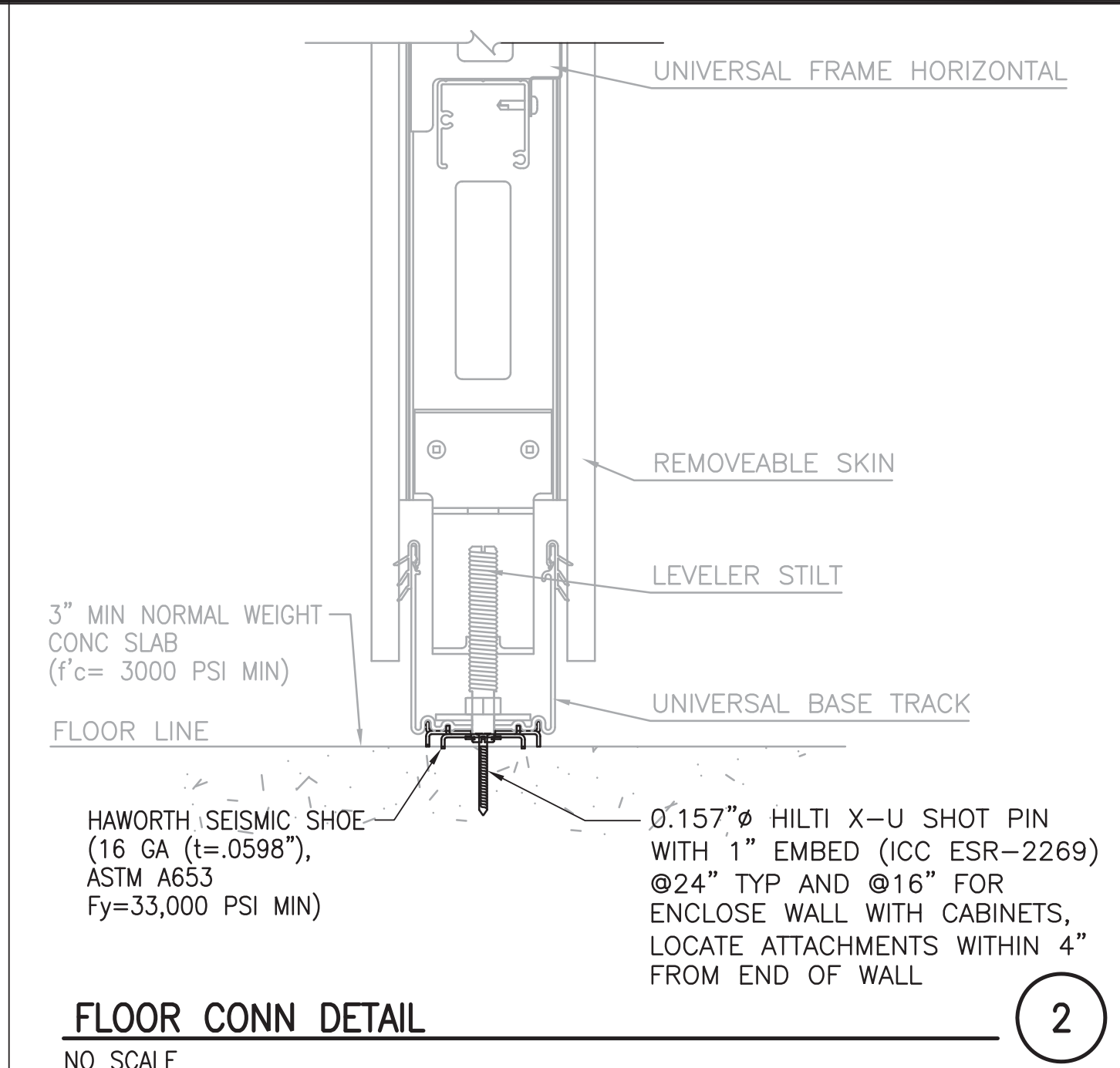

FLOOR CONN DETAIL
NO SCALE

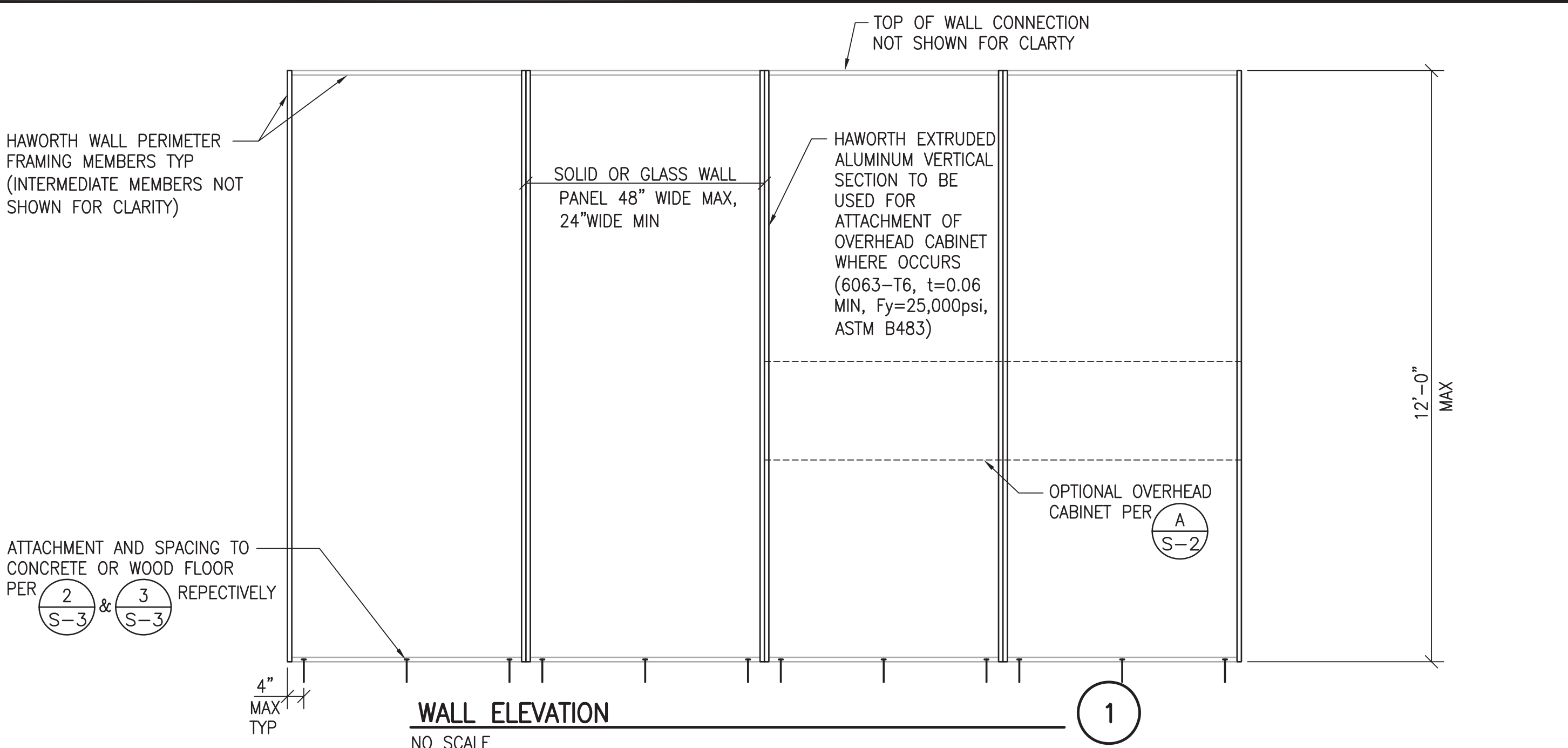

WALL ELEVATION
NO SCALE

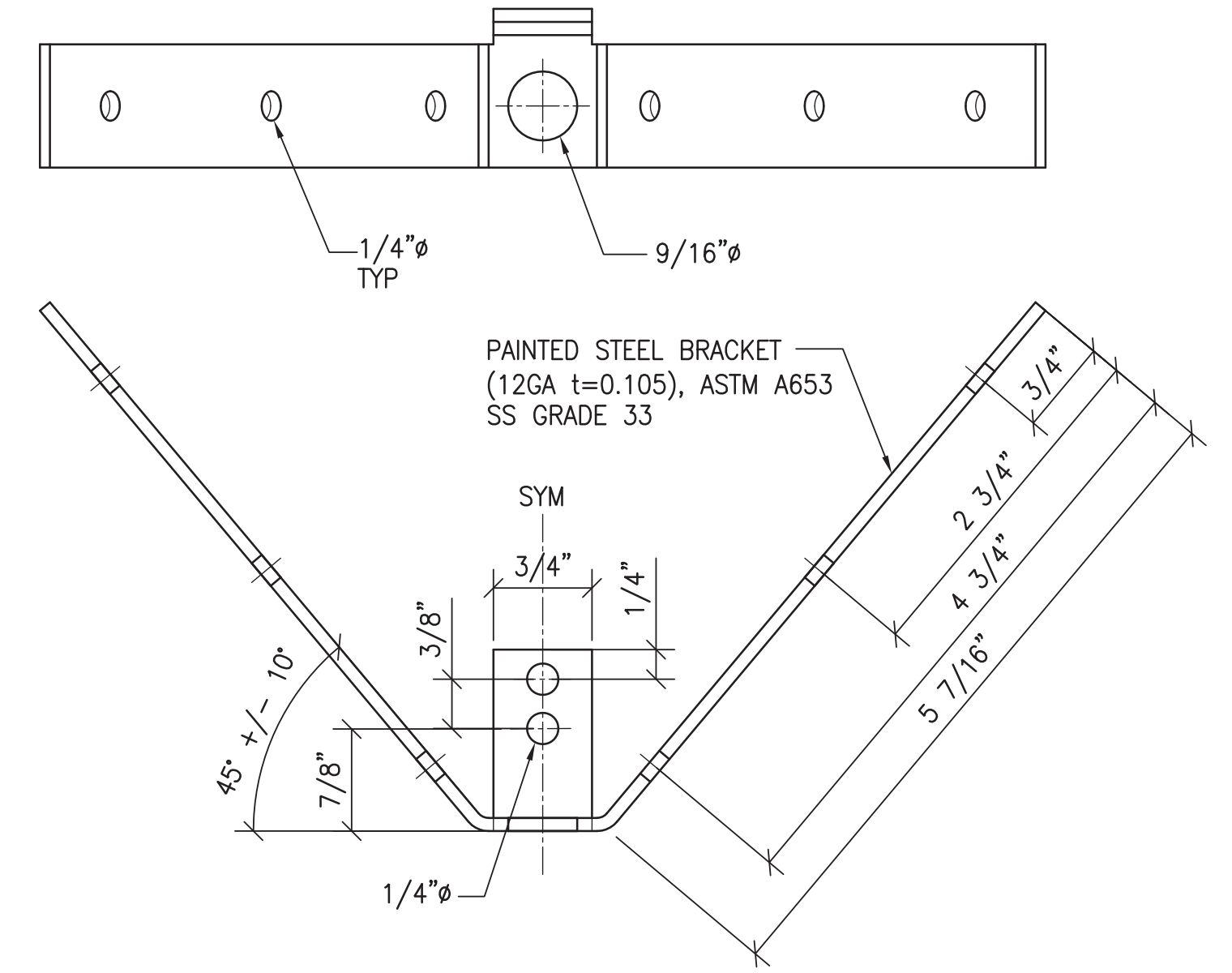

"Y" BRACKET BOLT ASSEMBLY DETAIL
NO SCALE

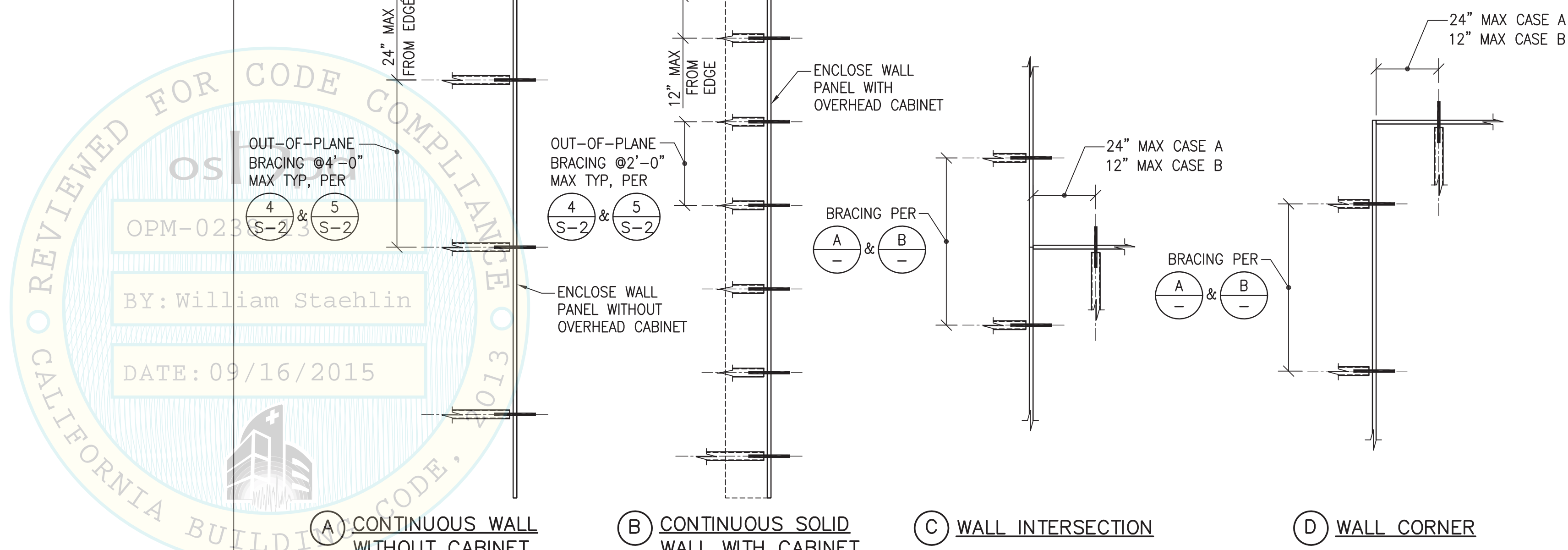

TOP OF ENCLOSE WALL BRACING PLAN
NO SCALE

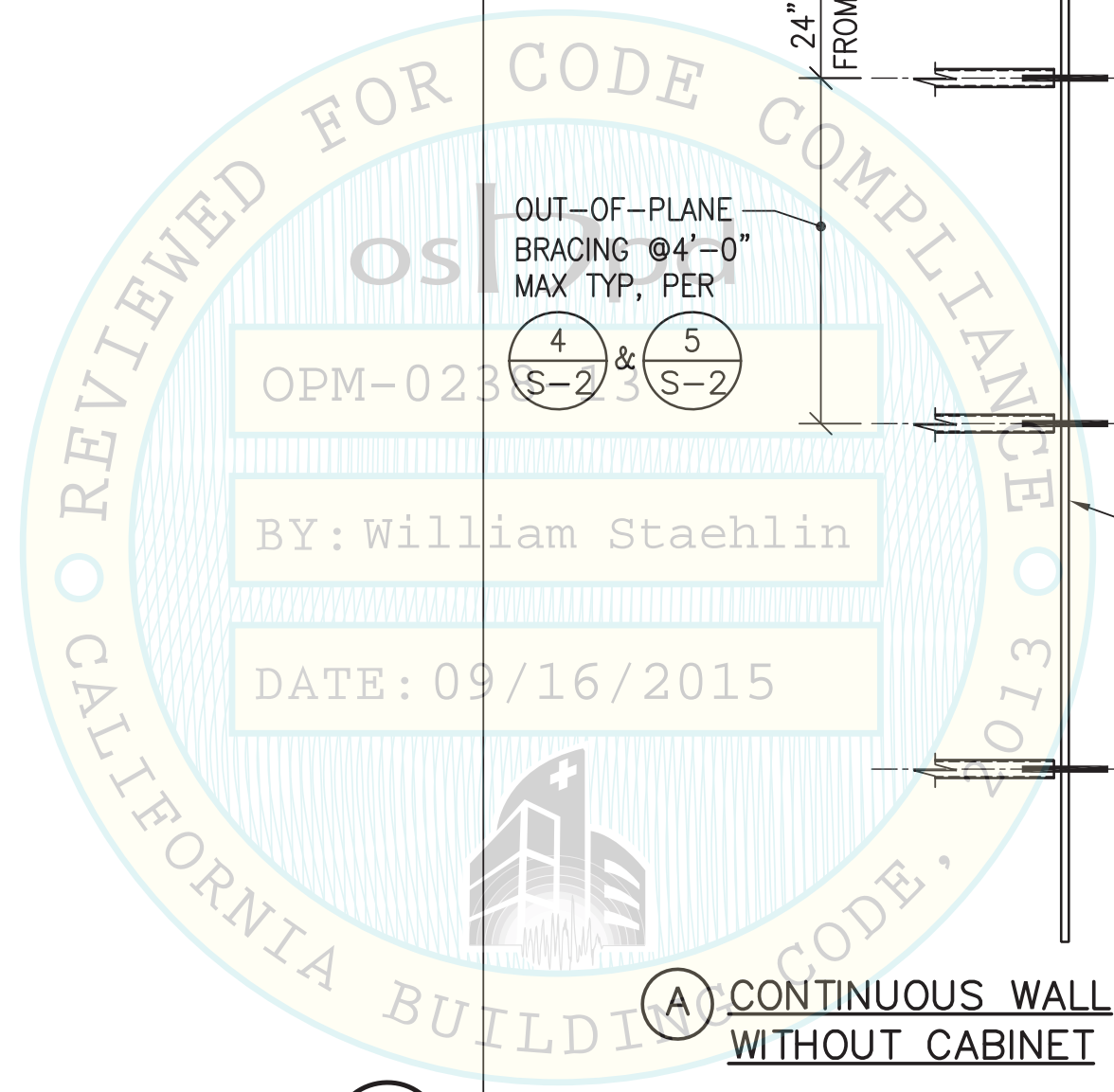

<p>CONDITIONS GOVERNING USE OF THIS DOCUMENT: The user of this document shall be responsible for verifying the accuracy of the information contained herein and for obtaining the necessary permits and approvals from the appropriate authorities. The user shall be responsible for obtaining the necessary permits and approvals from the appropriate authorities. The user shall be responsible for obtaining the necessary permits and approvals from the appropriate authorities.</p>	
ISSUE	DATE
<p>SECTION TITLE: HAWORTH OPM</p> <p>PROJECT: PROJECT XX ADDRESS XX</p>	
<p>SHEET NUMBER: J1313-00</p> <p>DATE: 08-25-15</p>	
<p>SHEET NUMBER: S-3 OF SKETCHES</p>	
<p>HAWORTH®</p> <p>JOHN A. MARTIN & ASSOCIATES, INC.</p> <p>STRUCTURAL ENGINEERS</p> <p>980 S. GRAND AVENUE LOS ANGELES, CALIF. 90015</p>	