



DEPARTMENT OF HEALTH CARE ACCESS AND INFORMATION
FACILITIES DEVELOPMENT DIVISION

APPLICATION FOR HCAI PREAPPROVAL OF
MANUFACTURER'S CERTIFICATION (OPM)

OFFICE USE ONLY

APPLICATION #: OPM-0260

HCAI Preapproval of Manufacturer's Certification (OPM)

Type: New Renewal/Update

Manufacturer Information

Manufacturer: Chatsworth Products

Manufacturer's Technical Representative: Todd Schneider

Mailing Address: 4175 Guardian Street, Simi Valley, CA 93063

Telephone: (203) 969-4862

Email: TSchneider@chatsworth.com

Product Information

Product Name: QUADRARACK

OPM-0260

Product Type: Instrumentation Cabinet

Product Model Number: 50120-X03

BY: William Staehlin

General Description: Telecommunication Rack

DATE: 08/03/2023

Applicant Information

Applicant Company Name: EASE LLC.

Contact Person: Tiffany Tonn

Mailing Address: 1515 FAIRVIEW AVE, STE 205, MISSOULA, MT 59801

Telephone: (406) 541-3273

Email: tiffany@easeco.com

Title: Office Manager

"A healthier California where all receive equitable, affordable, and quality health care"

STATE OF CALIFORNIA – HEALTH AND HUMAN SERVICES AGENCY





**DEPARTMENT OF HEALTH CARE ACCESS AND INFORMATION
FACILITIES DEVELOPMENT DIVISION**

Registered Design Professional Preparing Engineering Recommendations

Company Name: EASE LLC
Name: Jonathan Roberson California License Number: S4197
Mailing Address: 5877 Pine Ave., Suite 210, Chino Hills, CA 91709
Telephone: (951) 295-1892 Email: jon@EASECo.com

HCAI Special Seismic Certification Preapproval (OSP)

Special Seismic Certification is preapproved under OSP OSP Number: _____

Certification Method

Testing in accordance with: ICC-ES AC156 FM 1950-16
 Other(s) (Please Specify): _____

*Use of criteria other than those adopted by the California Building Standards Code, 2022 (CBSC 2022) for component supports and attachments are not permitted. For distribution system, interior partition wall, and suspended ceiling seismic bracings, test criteria other than those adopted in the CBSC 2022 may be used when approved by HCAI prior to testing.

Analysis
 Experience Data
 Combination of Testing, Analysis, and/or Experience Data (Please Specify): _____

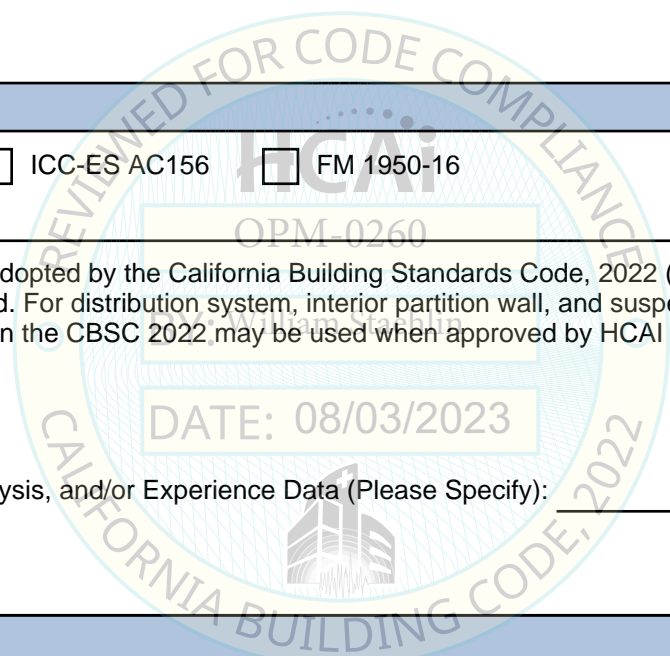

HCAI Approval

Date: 8/3/2023
Name: William Staehlin Title: Senior Structural Engineer
Condition of Approval (if applicable): _____

"A healthier California where all receive equitable, affordable, and quality health care"

STATE OF CALIFORNIA – HEALTH AND HUMAN SERVICES AGENCY



EASE

**EQUIPMENT ANCHORAGE
& SEISMIC ENGINEERING**

5877 Pine Ave, Ste. 210
Chino Hills, CA. 91709
Phn: (909) 606-7622

The Department of Health Care Access and Information
PREAPPROVAL OF MANUFACTURER'S CERTIFICATION
OPM-0260

THIS PREAPPROVAL CONFORMS TO THE 2022 CALIFORNIA BUILDING CODE

MANUFACTURER: **CHATSWORTH PRODUCTS, INC**
EQUIPMENT NAME: **QuadraRack MODEL NO. 50120-X03**

Sheet: 1 of 9
Date: 6/15/23

GENERAL NOTES

1. THIS HCAI PREAPPROVAL OF MANUFACTURER'S CERTIFICATION (OPM) IS BASED ON THE 2022 CBC. THE DEMANDS (DESIGN FORCES) FOR USE WITH THIS OPM SHALL BE BASED ON THE 2022 CBC
2. THIS DOCUMENT MAY ONLY BE USED WITH THE EXPRESS WRITTEN CONSENT OF THE MANUFACTURER LISTED ABOVE FOR THE SPECIFIC PROJECT SITE AND INSTALLATION LOCATION. THIS DOCUMENT IS INVALID WITHOUT SUCH CONSENT.
3. THIS PREAPPROVAL CONFORMS TO THE 2022 CALIFORNIA BUILDING CODE WHERE S_{ds} IS NOT GREATER THAN 2.00 & 2.30. SEE DETAIL FOR APPLICABILITY
4. FORCES PER ASCE 7-16 SECTION 13.3.1, EQUATIONS 13.3-1, 13.3-2 & 13.3-3,
WHERE $S_{ds} = 2.00$, $a_p = 2.5$, $I_p = 1.5$, $R_p = 6.0$, $z/h = 0$ AT CONCRETE SLAB. SEE FOLLOWING SHEETS FOR Ω_o
WHERE $S_{ds} = 2.30$, $a_p = 2.5$, $I_p = 1.5$, $R_p = 6.0$, $z/h = 0$ AT CONCRETE SLAB & $z/h \leq 1$ AT CONCRETE SLAB ON METAL DECK.
SEE FOLLOWING SHEETS FOR Ω_o
5. THIS PREAPPROVAL COVERS ONLY THE SUPPORTS AND ATTACHMENTS OF THE EQUIPMENT TO THE STRUCTURE.
6. ALL DESIGN FORCES SHOWN ON THE DRAWINGS ARE FACTORED LOADS THAT SHALL BE USED FOR STRENGTH DESIGN.
7. CONCRETE SLAB ON METAL DECK DETAIL VALID FOR DEMANDS SHOWN AT ANY ELEVATION IN THE BUILDING. (i.e. $z/h \leq 1$)
8. CONCRETE SLAB DETAIL VALID FOR DEMANDS SHOWN AT OR BELOW GRADE. (i.e. $z/h = 0$)

9. RESPONSIBILITIES OF THE STRUCTURAL ENGINEER OF RECORD OF THE BUILDING

- A. PROVIDE SUPPORTING STRUCTURE TO SUPPORT WEIGHTS AND FORCES SHOWN IN ADDITION TO ALL OTHER LOADS.
- B. VERIFY THAT THE INSTALLATION IS IN CONFORMANCE WITH THE 2022 CBC AND WITH THE DETAILS, MATERIAL AND GAGE OF THE UNIT WHERE ATTACHMENTS ARE MADE AGREE WITH THE INFORMATION SHOWN ON THE PREAPPROVAL DOCUMENTS.
- C. VERIFY THAT PROJECT SPECIFIC VALUES OF S_{ds} & z/h RESULT IN SEISMIC FORCES (E_h , E_v) THAT DO NOT EXCEED THE VALUES ON THE DETAILS.
- D. VERIFY THAT THE CONCRETE SLAB TO WHICH THE EQUIPMENT IS ANCHORED MEETS THE REQUIREMENTS OF THE APPLICABLE ICC ESR REPORT. AND THIS OPM.
- E. VERIFY THAT THE ANCHORS ARE AN ADEQUATE DISTANCE FROM ANY SLAB EDGES OR OPENINGS (SEE TYPICAL DETAIL ON SHEET 2).
- F. VERIFY THAT ALL NEW OR EXISTING ANCHORS ARE AN ADEQUATE DISTANCE FROM THE UNIT ATTACHMENTS AND CHECK FOR INTERACTION WHERE OTHER ANCHORS ARE WITHIN 18" OR $6h_{ef}$ FROM THIS UNIT'S ANCHORS.



CHATSWORTH PRODUCTS, INC

DES. **J. ROBERSON**

SHEET

2

JOB NO. **11-2314**

9

QuadraRack MODEL NO. 50120-X03

DATE **6/15/23**

OF SHEETS

10. EXPANSION ANCHORS:

- A. ATTACHMENT IS TO BE MADE WITH THE ANCHORS LISTED BELOW AND INSTALLED AS DESCRIBED IN THE CORRESPONDING ICC REPORT.

Anchor Diameter	Concrete Type	Min. f'c (psi)	Anchor Type	ICC Report No.	Min. Embed.	Min. Spacing	Min. Edge Dist.	Min. Conc. Thickness	Torque Test	Direct Tension Test
3/8"	Sand Light Weight	3000	Hilti Kwik Bolt TZ2 (CARBON STEEL)	ESR-4266	2"	6.75"	12"	See Detail "A"	30 FT-LB	N/A
5/8"	Normal Weight	3000	Hilti Kwik Bolt TZ2 (CARBON STEEL)	ESR-4266	3.25"	12"	32"	6"	40 FT-LB	4106 lb
5/8"	Normal Weight	3000	Hilti Kwik Bolt TZ2 (CARBON STEEL)	ESR-4266	4"	12"	26"	6"	40 FT-LB	4538lb

- B. THIS PREAPPROVAL ALLOWS FOR UP TO A MAXIMUM OF 2 ADJACENT CONCRETE SLAB EDGES, (SEE SCHEDULE) AWAY MINIMUM (i.e. - CORNER). SEE ADJACENT DETAIL FOR ADDITIONAL MINIMUM ALLOWABLE CONCRETE EDGE DISTANCES.

- C. TESTING AND SPECIAL INSPECTION OF EXPANSION ANCHORS SHALL BE PERFORMED BY AN APPROVED INDEPENDENT AGENCY EMPLOYED BY THE FACILITY OWNER PER CBC 1704A & 1910A.5 AND CAC 7-149. ALL REPORTS SHALL BE SENT TO THE INSPECTOR OF RECORD, OWNER AND THE ARCHITECT OR ENGINEER IN RESPONSIBLE CHARGE.

- (i) AFTER AT LEAST 24 HOURS HAVE ELAPSED SINCE INSTALLATION, DIRECT PULL TENSION TEST OR TORQUE TEST AT LEAST 50% OF THE ANCHORS.

- (ii) ACCEPTANCE CRITERIA:

- DIRECT TENSION TEST: THE ANCHOR SHOULD HAVE NO OBSERVABLE MOVEMENT AT THE TEST LOAD. A PRACTICAL WAY TO DETERMINE OBSERVABLE MOVEMENT IS THAT THE WASHER BECOMES LOOSE.
- TORQUE TEST: THE APPLICABLE TORQUE MUST BE ACHIEVED WITHIN THE FOLLOWING LIMITS: WEDGE TYPE : 1/2 TURN OF THE NUT

- (iii) IF ANY ANCHOR FAILS, TEST ALL ANCHORS.

- D. AVOID DAMAGING EXISTING STEEL REINFORCING IN CONCRETE SLAB WHEN INSTALLING CONCRETE EXPANSION ANCHORS.
E. PROVIDE FOR FULL THREAD ENGAGEMENT OF NUT & WASHER.

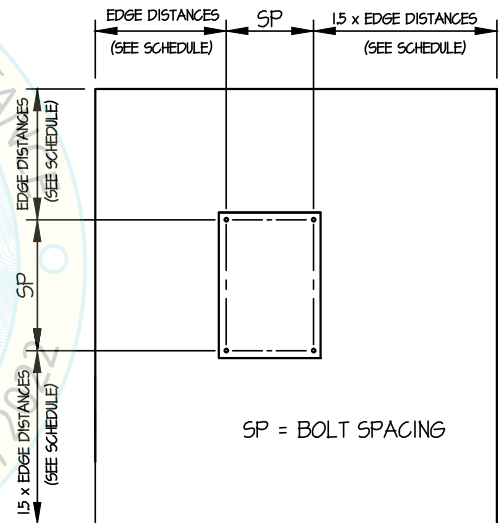

TYPICAL CONCRETE EDGE DETAIL
(SLAB ON GRADE ONLY)

11. BOLTS THROUGH CONCRETE ON METAL DECK

- A. BOLTS SHALL BE TORQUED BY 3/4 TURN OF THE NUTS AFTER THE SNUG TIGHT (THE SNUG-TIGHT CONDITION IS DEFINED AS THE TIGHTNESS REQUIRED TO BRING THE CONNECTED PLIES INTO FIRM CONTACT) CONDITION IS ACHIEVED, UNLESS OTHERWISE NOTED.
- B. THROUGH BOLT HOLES SHALL BE 1/16" LARGER THAN BOLT SIZE (HOLE SIZE = BOLT SIZE + 1/16) FOR CONCRETE.
- C. THROUGH-BOLTS IN CONCRETE SHALL RECEIVE SPECIAL INSPECTION AND TESTING (THROUGH BOLTS WITH STEEL TO STEEL CONNECTION IN TENSION DO NOT REQUIRE TENSION TESTING) IN ACCORDANCE WITH REQUIREMENTS FOR POST-INSTALLED ANCHORS.



CHATSWORTH PRODUCTS, INC

DES. **J. ROBERSON**

SHEET

3

JOB NO. **11-2314**

QuadraRack MODEL NO. 50120-X03

DATE **6/15/23**

OF **9** SHEETS

SEISMIC SUPPORTS & ATTACHMENTS

CONCRETE SLAB

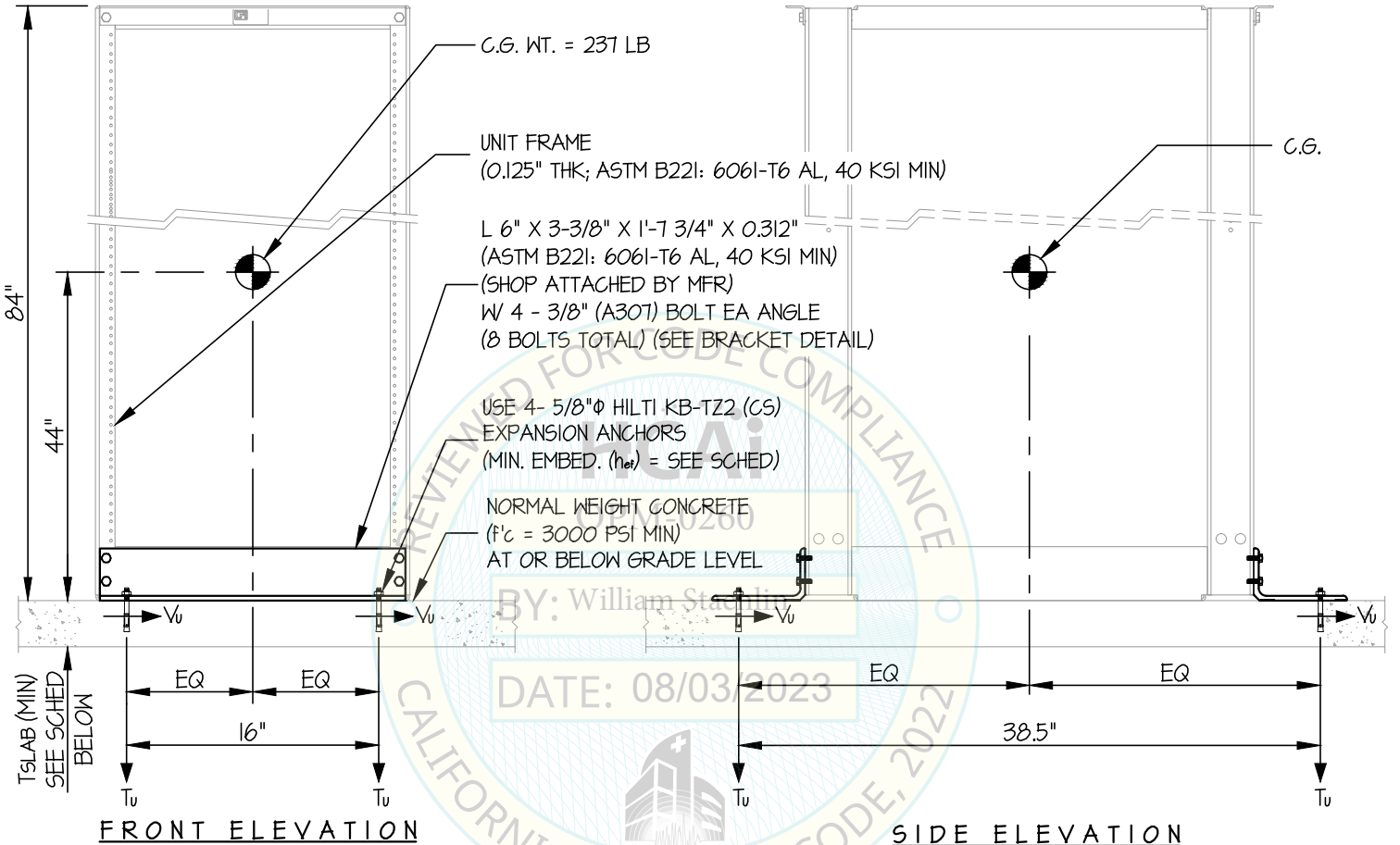

ANCHORS							
MAX Sds	TYPE	DIAM	EFF EMBED	QTY	T _{SLAB}	*T _u (lb)	*V _u (lb)
200	HILTI KB-TZ2	5/8"	3.125"	4	6"	2886	139
230	HILTI KB-TZ2	5/8"	4"	4	6"	3357	159

* VALUES INCLUDE Ω_0

NOTES:

- FORCES ARE DETERMINED PER 2022 CALIFORNIA BUILDING CODE AND ASCE 7-16. STRENGTH DESIGN IS USED. (EXAMPLE: $a_p = 2.5$, $l_p = 1.5$, $R_p = 6.0$, $\Omega_0 = 2.5$, $z/h = 0$)
- THIS PREAPPROVAL ENCOMPASSES WEIGHTS AND VERTICAL C.G. POSITIONS NOT EXCEEDING VALUES SHOWN.
- THIS PREAPPROVAL WAS PREPARED WITHOUT KNOWLEDGE OF ANY SITE CONDITION. COMPATIBILITY FOR USE WITH A SITE SHALL BE EVALUATED BY THE STRUCTURAL ENGINEER OF RECORD OF THE INSTALLATION (SEOR). USE REQUIRES APPROVAL BY THE SEOR.
- STRUCTURAL ENGINEER OF RECORD FOR THE INSTALLATION SHALL VERIFY ALL CONDITIONS, EVALUATE INTERACTION WITH ADJACENT EQUIPMENT AND ANCHORS, AND PROVIDE SUPPORT STRUCTURE DESIGNED TO SUPPORT WEIGHTS AND FORCES SHOWN IN COMBINATION WITH ALL OTHER LOADS THAT MAY BE PRESENT.
- SEE GENERAL NOTES: SHEETS 1 AND 2



CHATSWORTH PRODUCTS, INC

DES. **J. ROBERSON**

SHEET

4

JOB NO. **11-2314**

QuadraRack MODEL NO. 50120-X03

DATE **6/15/23**

OF **9** SHEETS

SEISMIC SUPPORTS & ATTACHMENTS

CONCRETE SLAB

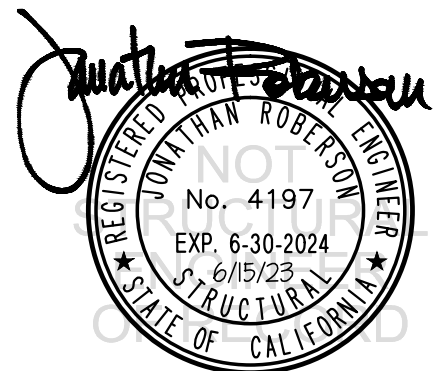
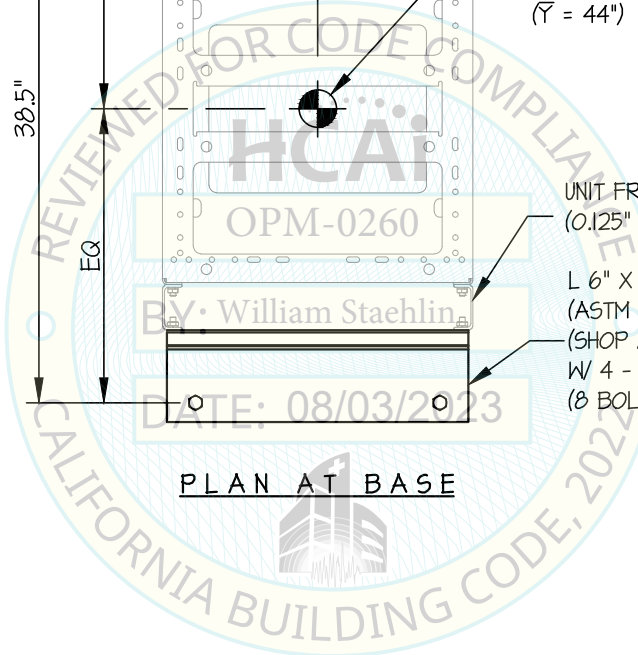
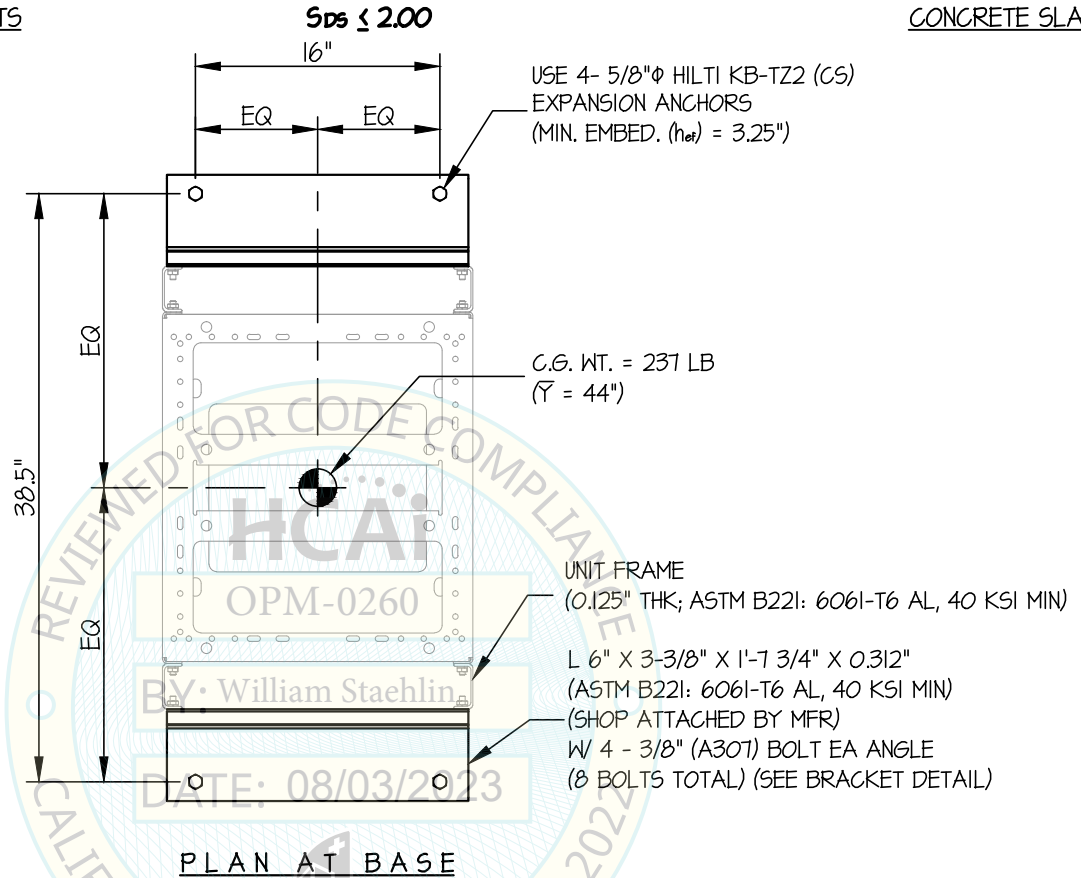

CHATSWORTH PRODUCTS, INC

QuadraRack MODEL NO. 50120-X03

DES. **J. ROBERSON**

JOB NO. **11-2314**

DATE **6/15/23**

SHEET

5

OF **9** SHEETS

SEISMIC SUPPORTS & ATTACHMENTS

CONCRETE SLAB

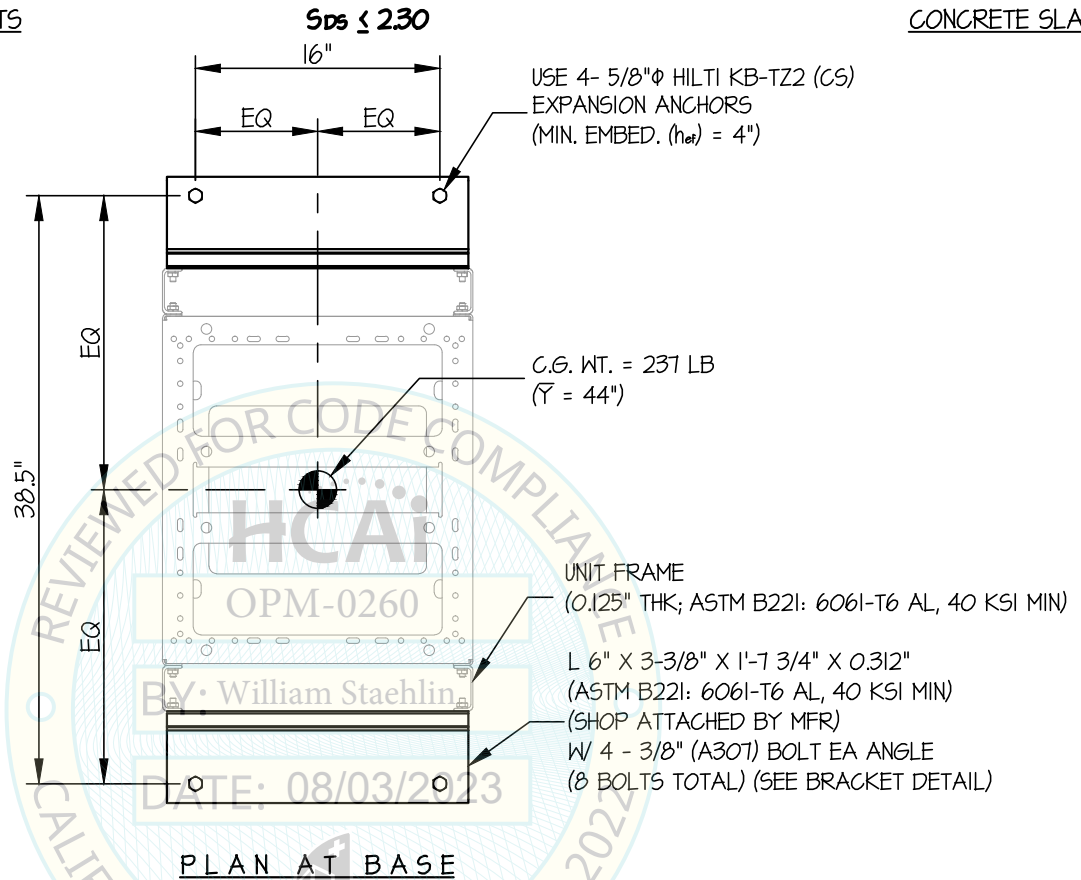

Jonathan Roberson
REGISTERED PROFESSIONAL ENGINEER
JONATHAN ROBERSON
No. 4197
EXP. 6-30-2024
6/15/23
STRUCTURAL
STATE OF CALIFORNIA

CHATSWORTH PRODUCTS, INC

DES. J. ROBERSON

SHEET

6

JOB NO. 11-2314

OF 9

SHEETS

QuadraRack MODEL NO. 50120-X03

DATE 6/15/23

SEISMIC SUPPORTS & ATTACHMENTS

CONCRETE SLAB

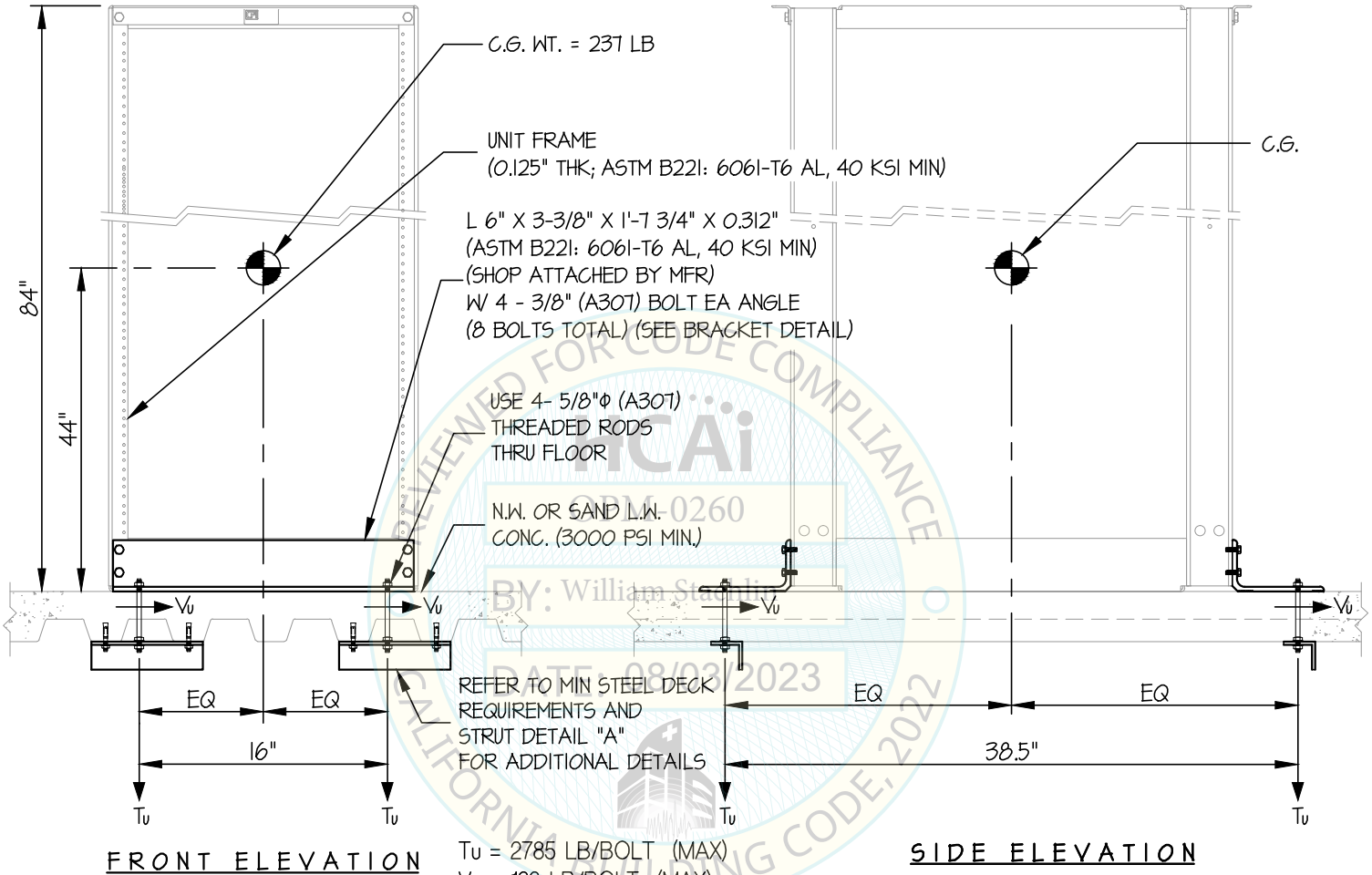

NOTES:

- FORCES ARE DETERMINED PER 2022 CALIFORNIA BUILDING CODE AND ASCE 7-16. STRENGTH DESIGN IS USED. (EXAMPLE: $S_{ds} = 2.30$, $a_p = 2.5$, $I_p = 1.5$, $R_p = 6.0$, $\Omega_o = 2.5$, $z/h \leq 1$)
 - HORIZONTAL FORCE (E_h) = $1.73 W_p$
 - HORIZONTAL FORCE (E_{mh}) = $3.46 W_p$ (FOR CONCRETE ANCHORAGE)
 - VERTICAL FORCE (E_v) = $0.46 W_p$
- THIS CALCULATION ENCOMPASSES WEIGHTS AND VERTICAL C.G. POSITIONS NOT EXCEEDING VALUES SHOWN.
- THIS CALCULATION WAS PREPARED WITHOUT KNOWLEDGE OF ANY SITE CONDITION. COMPATIBILITY FOR USE WITH A SITE SHALL BE EVALUATED BY THE STRUCTURAL ENGINEER OF RECORD OF THE INSTALLATION (SEOR). USE REQUIRES APPROVAL BY THE SEOR.
- STRUCTURAL ENGINEER OF RECORD FOR THE INSTALLATION SHALL VERIFY ALL CONDITIONS, EVALUATE INTERACTION WITH ADJACENT EQUIPMENT AND ANCHORS, AND PROVIDE SUPPORT STRUCTURE DESIGNED TO SUPPORT WEIGHTS AND FORCES SHOWN IN COMBINATION WITH ALL OTHER LOADS THAT MAY BE PRESENT.
- SEE GENERAL NOTES: SHEETS 1 AND 2

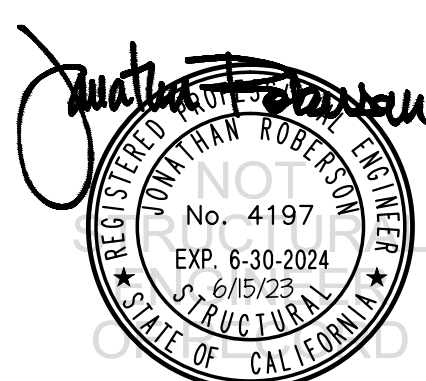

CHATSWORTH PRODUCTS, INC

DES. **J. ROBERSON**

SHEET

7

JOB NO. **11-2314**

QuadraRack MODEL NO. 50120-X03

DATE **6/15/23**

OF **9** SHEETS

SEISMIC SUPPORTS & ATTACHMENTS

CONCRETE SLAB

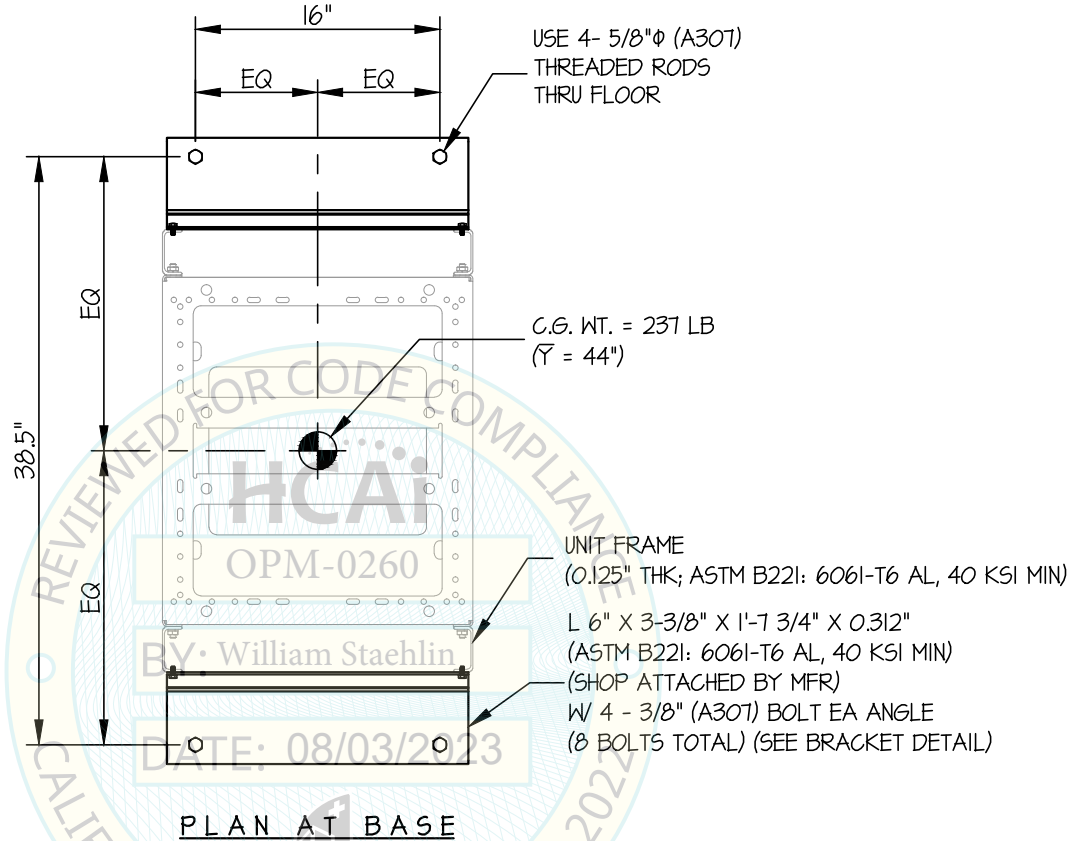

Jonathan Roberson
 REGISTERED PROFESSIONAL ENGINEER
 JONATHAN ROBERSON
 No. 4197
 EXP. 6-30-2024
 6/15/23
 STRUCTURAL
 STATE OF CALIFORNIA

CHATSWORTH PRODUCTS, INC

DES. **J. ROBERSON**

SHEET

8

JOB NO. **11-2314**

OF **9**

SHEETS

QuadraRack MODEL NO. 50120-X03

DATE **6/15/23**

SEISMIC SUPPORTS & ATTACHMENTS

CONCRETE DETAILS

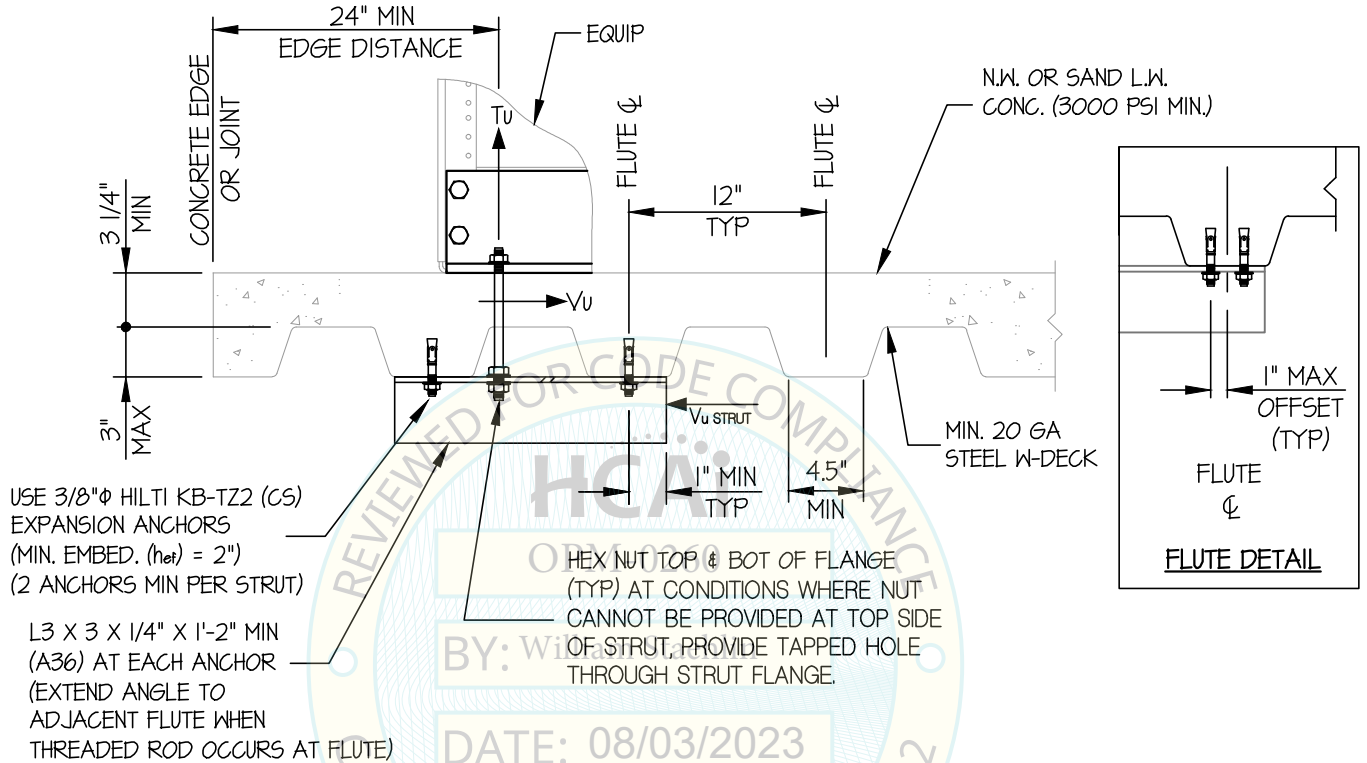

MIN STEEL DECK REQUIREMENTS AND STRUT DETAIL (A)

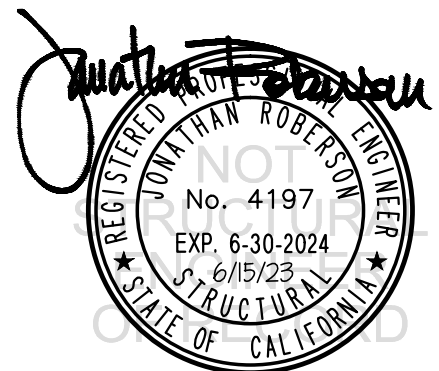

CHATSWORTH PRODUCTS, INC

DES. **J. ROBERSON**

SHEET

9

QuadraRack MODEL NO. 50120-X03

JOB NO. **11-2314**

DATE **6/15/23**

OF **9** SHEETS

SEISMIC SUPPORTS & ATTACHMENTS

BRACKET DETAILS

