



DEPARTMENT OF HEALTH CARE ACCESS AND INFORMATION  
FACILITIES DEVELOPMENT DIVISION

APPLICATION FOR HCAI PREAPPROVAL OF  
MANUFACTURER'S CERTIFICATION (OPM)

OFFICE USE ONLY

APPLICATION #: OPM-0286

HCAI Preapproval of Manufacturer's Certification (OPM)

Type:  New  Renewal/Update

Manufacturer Information

Manufacturer: Legrand AV

Manufacturer's Technical Representative: Michael Harrell

Mailing Address: 6436 City West Parkway, Eden Prairie, MN 55344

Telephone: (952) 225-6313

Email: michael.harrell@legrand.com

Product Information

Product Name: MTMP1U SERIES MONITOR WALL MOUNTS0286

Product Type: Computer

Product Model Number: MTMP1U

General Description: Wall Mount for Video Monitor

BY: William Staehlin

DATE: 01/29/2024

Applicant Information

Applicant Company Name: EASE LLC.

Contact Person: Tiffany Tonn

Mailing Address: 1515 FAIRVIEW AVE, STE 205, MISSOULA, MT 59801

Telephone: (406) 541-3273

Email: tiffany@easeco.com

Title: Office Assistant

*"A healthier California where all receive equitable, affordable, and quality health care"*

STATE OF CALIFORNIA – HEALTH AND HUMAN SERVICES AGENCY





**DEPARTMENT OF HEALTH CARE ACCESS AND INFORMATION  
FACILITIES DEVELOPMENT DIVISION**

**Registered Design Professional Preparing Engineering Recommendations**

Company Name: EASE LLC  
Name: Jonathan Roberson California License Number: S4197  
Mailing Address: 5877 Pine Ave., Suite 210, Chino Hills, CA 91709  
Telephone: (951) 295-1892 Email: jon@EASECo.com

**HCAI Special Seismic Certification Preapproval (OSP)**

Special Seismic Certification is preapproved under OSP OSP Number: \_\_\_\_\_

**Certification Method**

Testing in accordance with:  ICC-ES AC156  FM 1950-16  
 Other(s) (Please Specify): \_\_\_\_\_

\*Use of criteria other than those adopted by the California Building Standards Code, 2022 (CBSC 2022) for component supports and attachments are not permitted. For distribution system, interior partition wall, and suspended ceiling seismic bracings, test criteria other than those adopted in the CBSC 2022 may be used when approved by HCAI prior to testing.

Analysis  
 Experience Data  
 Combination of Testing, Analysis, and/or Experience Data (Please Specify): \_\_\_\_\_

**HCAI Approval**

Date: 1/29/2024  
Name: William Staehlin Title: Senior Structural Engineer  
Condition of Approval (if applicable): \_\_\_\_\_

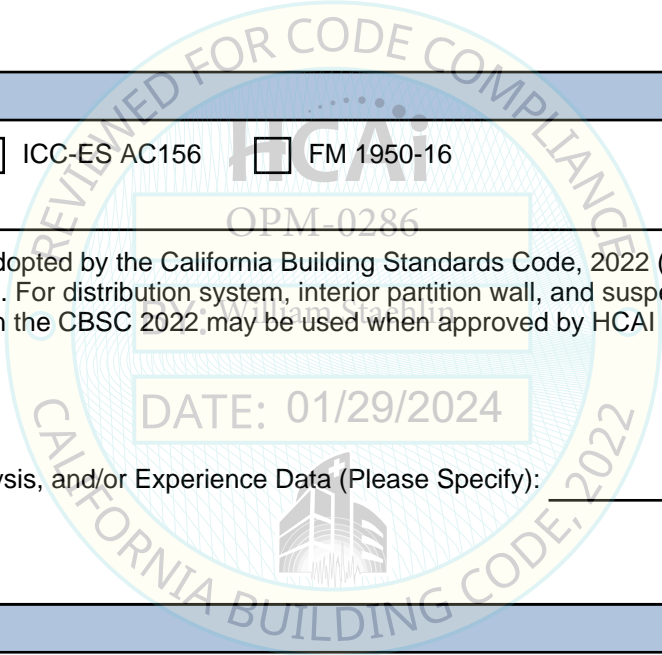

*"A healthier California where all receive equitable, affordable, and quality health care"*

**STATE OF CALIFORNIA – HEALTH AND HUMAN SERVICES AGENCY**





**EQUIPMENT ANCHORAGE  
& SEISMIC ENGINEERING**

5877 Pine Ave, Ste. 210  
Chino Hills, CA. 91709  
Phn: (909) 606-7622

The Department of Health Care Access and Information  
**PREAPPROVAL OF MANUFACTURER'S CERTIFICATION**  
**OPM-0286**

**THIS PREAPPROVAL CONFORMS TO THE 2022 CALIFORNIA BUILDING CODE**

MANUFACTURER: **MILESTONE INC.**  
EQUIPMENT NAME: **MTMP1U SERIES MONITOR WALL MOUNT**

Sheet: 1 of 6  
Date: 1/23/24

**GENERAL NOTES**

1. THIS HCAI PREAPPROVAL OF MANUFACTURER'S CERTIFICATION (OPM) IS BASED ON THE 2022 CBC. THE DEMANDS (DESIGN FORCES) FOR USE WITH THIS OPM SHALL BE BASED ON THE 2022 CBC
2. THIS DOCUMENT MAY ONLY BE USED WITH THE EXPRESS WRITTEN CONSENT OF THE MANUFACTURER LISTED ABOVE FOR THE SPECIFIC PROJECT SITE AND INSTALLATION LOCATION. THIS DOCUMENT IS INVALID WITHOUT SUCH CONSENT.
3. THIS PREAPPROVAL CONFORMS TO THE 2022 CALIFORNIA BUILDING CODE WHERE  $S_{ds}$  IS NOT GREATER THAN 2.00.
4. FORCES PER ASCE 7-16 SECTION 13.3.1, EQUATIONS 13.3-1, 13.3-2 & 13.3-3,  
WHERE  $S_{ds} = 2.00$ ,  $a_p = 1.0$ ,  $I_p = 1.5$ ,  $R_p = 2.5$ ,  $z/h \leq 1$  CONCRETE WALL. SEE FOLLOWING SHEETS FOR  $\Omega_0$ .
5. THIS PREAPPROVAL COVERS ONLY THE SUPPORTS AND ATTACHMENTS OF THE EQUIPMENT TO THE STRUCTURE.
6. ALL DESIGN FORCES SHOWN ON THE DRAWINGS ARE FACTORED LOADS THAT SHALL BE USED FOR STRENGTH DESIGN.
7. SHEET METAL SCREWS SHALL BE TEKS SCREWS BY ITW BUILDEX (ICC ESR-1976).
8. CONCRETE WALL DETAIL VALID FOR DEMANDS SHOWN AT ANY ELEVATION. (i.e.  $z/h \leq 1$ )
9. **RESPONSIBILITIES OF THE STRUCTURAL ENGINEER OF RECORD OF THE BUILDING**
  - A. PROVIDE SUPPORTING STRUCTURE TO SUPPORT WEIGHTS AND FORCES SHOWN IN ADDITION TO ALL OTHER LOADS.
  - B. VERIFY THAT THE INSTALLATION IS IN CONFORMANCE WITH THE 2022 CBC AND WITH THE DETAILS, MATERIAL AND GAGE OF THE UNIT WHERE ATTACHMENTS ARE MADE AGREE WITH THE INFORMATION SHOWN ON THE PREAPPROVAL DOCUMENTS.
  - C. VERIFY THAT PROJECT SPECIFIC VALUES OF  $S_{ds}$  &  $z/h$  RESULT IN SEISMIC FORCES ( $E_h$ ,  $E_v$ ) THAT DO NOT EXCEED THE VALUES ON THE DETAILS.
  - D. VERIFY THAT THE CONCRETE WALL TO WHICH THE EQUIPMENT IS ANCHORED MEETS THE REQUIREMENTS OF THE APPLICABLE ICC ESR AND THIS OPM.
  - E. VERIFY THAT THE ANCHORS ARE AN ADEQUATE DISTANCE FROM ANY CONCRETE WALL EDGES OR OPENINGS (SEE TYPICAL DETAIL ON SHEET 2).
  - F. VERIFY THAT ALL NEW OR EXISTING ANCHORS ARE AN ADEQUATE DISTANCE FROM THE UNIT ATTACHMENTS AND CHECK FOR INTERACTION WHERE OTHER ANCHORS ARE WITHIN 18" OR  $6h_{ef}$  FROM THIS UNIT'S ANCHORS.
  - G. DESIGN BACKING BARS, STUDS, ETC. WHICH THE UNITS ARE ATTACHED TO AS NOTED ON THE DRAWINGS.

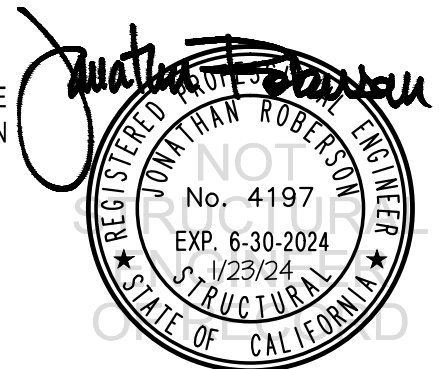

**MILESTONE INC.**

DES. **J. ROBERSON**

SHEET

**2**

**MTMP1U SERIES  
MONITOR WALL MOUNT**

JOB NO. **11-2334**

DATE **1/23/24**

OF **6** SHEETS

**10. SCREW ANCHORS:**

A. ATTACHMENT IS TO BE MADE WITH THE ANCHORS LISTED BELOW AND INSTALLED AS DESCRIBED IN THE CORRESPONDING ICC REPORT.

Anchor Diameter	Concrete Type	Min. f'c (psi)	Anchor Type	ICC Report No.	Min. Embed.	Min. Spacing	Min. Edge Dist.	Min. Conc. Thickness	Torque Test	Direct Tension
1/4"	Normal Weight	3000	Hilti Kwik HUS	ESR-3027	1.92"	2.5"	12"	6"	N/A	779

B. THIS PREAPPROVAL ALLOWS FOR UP TO A MAXIMUM OF 2 ADJACENT CONCRETE SLAB EDGES, 12" AWAY MINIMUM (i.e. - CORNER). SEE ADJACENT DETAIL FOR ADDITIONAL MINIMUM ALLOWABLE CONCRETE EDGE DISTANCES.

C. TESTING AND SPECIAL INSPECTION OF SCREW ANCHORS SHALL BE PERFORMED BY AN APPROVED INDEPENDENT AGENCY EMPLOYED BY THE FACILITY OWNER PER CBC 1704A & 1910A.5 AND CAC 7-149. ALL REPORTS SHALL BE SENT TO THE INSPECTOR OF RECORD, OWNER AND THE ARCHITECT OR ENGINEER IN RESPONSIBLE CHARGE.

(i) AFTER AT LEAST 24 HOURS HAVE ELAPSED SINCE INSTALLATION, DIRECT PULL TENSION TEST AT LEAST 50% OF THE ANCHORS.

(ii) ACCEPTANCE CRITERIA:

- DIRECT TENSION TEST: THE ANCHOR SHOULD HAVE NO OBSERVABLE MOVEMENT AT THE TEST LOAD. A PRACTICAL WAY TO DETERMINE OBSERVABLE MOVEMENT IS THAT THE WASHER BECOMES LOOSE.

(iii) IF ANY ANCHOR FAILS, TEST ALL ANCHORS.

D. AVOID DAMAGING EXISTING STEEL REINFORCING IN CONCRETE WALL WHEN INSTALLING CONCRETE SCREW ANCHORS

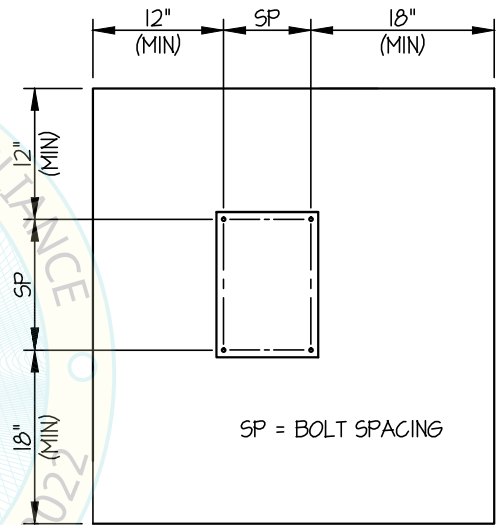

TYPICAL CONCRETE EDGE DETAIL

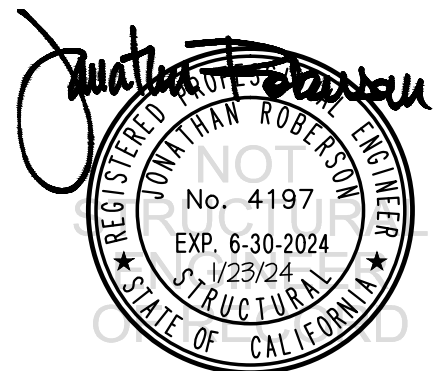
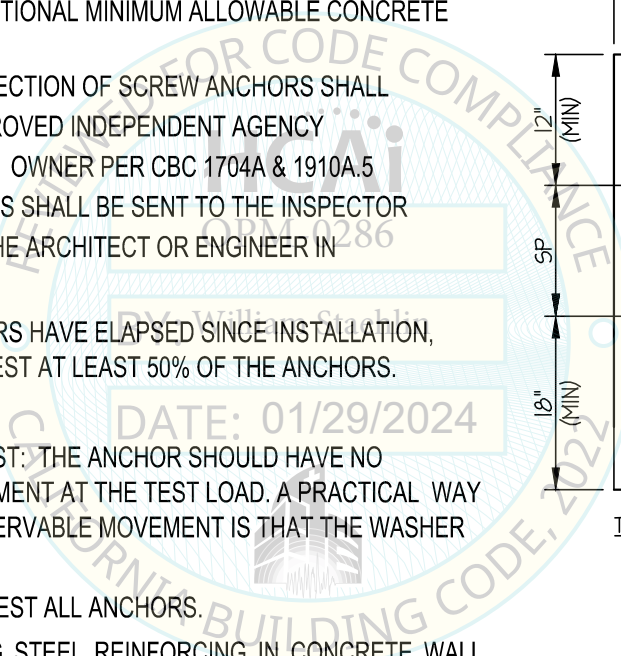

**MILESTONE INC.**

DES. **J. ROBERSON**

SHEET

**3**

**MTMP1U SERIES  
MONITOR WALL MOUNT**

JOB NO. **11-2334**

DATE **1/23/24**

OF **6** SHEETS

SEISMIC SUPPORTS & ATTACHMENTS

WALL MOUNTED

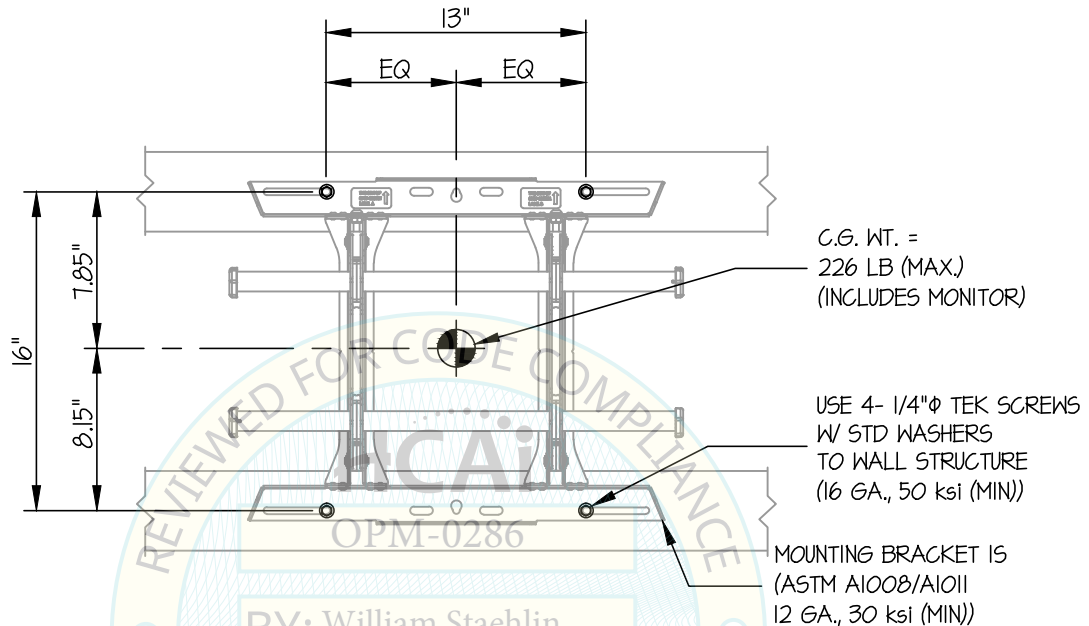

STEEL/WOOD STUD WALL  
 $T_u = 176 \text{ LB/SCREW (MAX)}$   
 $V_u = 189 \text{ LB/SCREW (MAX)}$   
 (VALUES DO NOT INCLUDE  $\Omega$ )

**ELEVATION AT WALL PLATE**  
(MTMP1U MODEL SHOWN)

**NOTES:**

- FORCES ARE DETERMINED PER 2022 CALIFORNIA BUILDING CODE AND ASCE 7-16. STRENGTH DESIGN IS USED. (EXAMPLE:  $S_{ds} = 2.00$ ,  $a_p = 1.0$ ,  $I_p = 1.5$ ,  $R_p = 2.5$ ,  $\Omega_o = 2.0$ ,  $z/h \leq 1$ )
  - HORIZONTAL FORCE ( $E_h$ ) =  $1.44 W_p$
  - HORIZONTAL FORCE ( $E_{mh}$ ) =  $2.88 W_p$  (FOR CONCRETE ANCHORAGE)
  - VERTICAL FORCE ( $E_v$ ) =  $0.40 W_p$
- THIS PREAPPROVAL ENCOMPASSES WEIGHTS AND VERTICAL CG POSITIONS UP TO THE VALUES SHOWN.
- THIS PREAPPROVAL WAS PREPARED WITHOUT KNOWLEDGE OF ANY SITE CONDITION. COMPATIBILITY FOR USE WITH A SITE SHALL BE EVALUATED BY THE STRUCTURAL ENGINEER OF RECORD OF THE INSTALLATION (SEOR). USE REQUIRES APPROVAL BY THE SEOR.
- STRUCTURAL ENGINEER OF RECORD FOR THE INSTALLATION SHALL VERIFY ALL CONDITIONS, EVALUATE INTERACTION WITH ADJACENT EQUIPMENT AND ANCHORS, AND PROVIDE SUPPORT STRUCTURE DESIGNED TO SUPPORT WEIGHTS AND FORCES SHOWN IN COMBINATION WITH ALL OTHER LOADS THAT MAY BE PRESENT.

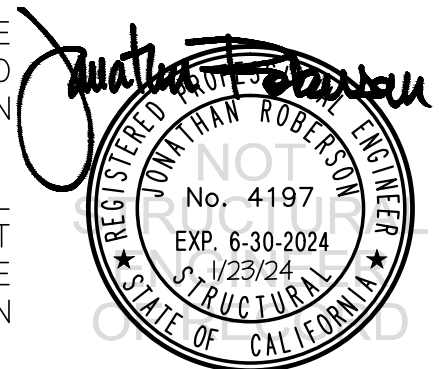

**MILESTONE INC.**

DES. **J. ROBERSON**

SHEET

**4**

**MTMP1U SERIES  
MONITOR WALL MOUNT**

JOB NO. **11-2334**

DATE **1/23/24**

OF **6** SHEETS

SEISMIC SUPPORTS & ATTACHMENTS

WALL MOUNTED

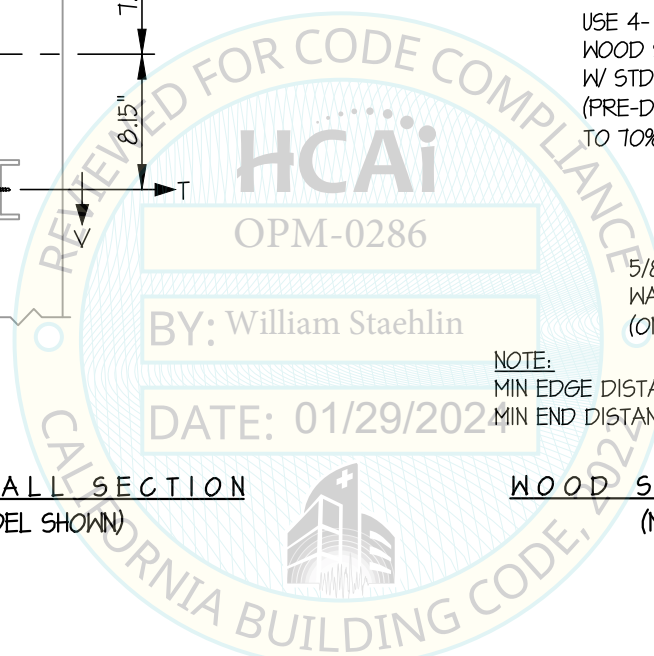
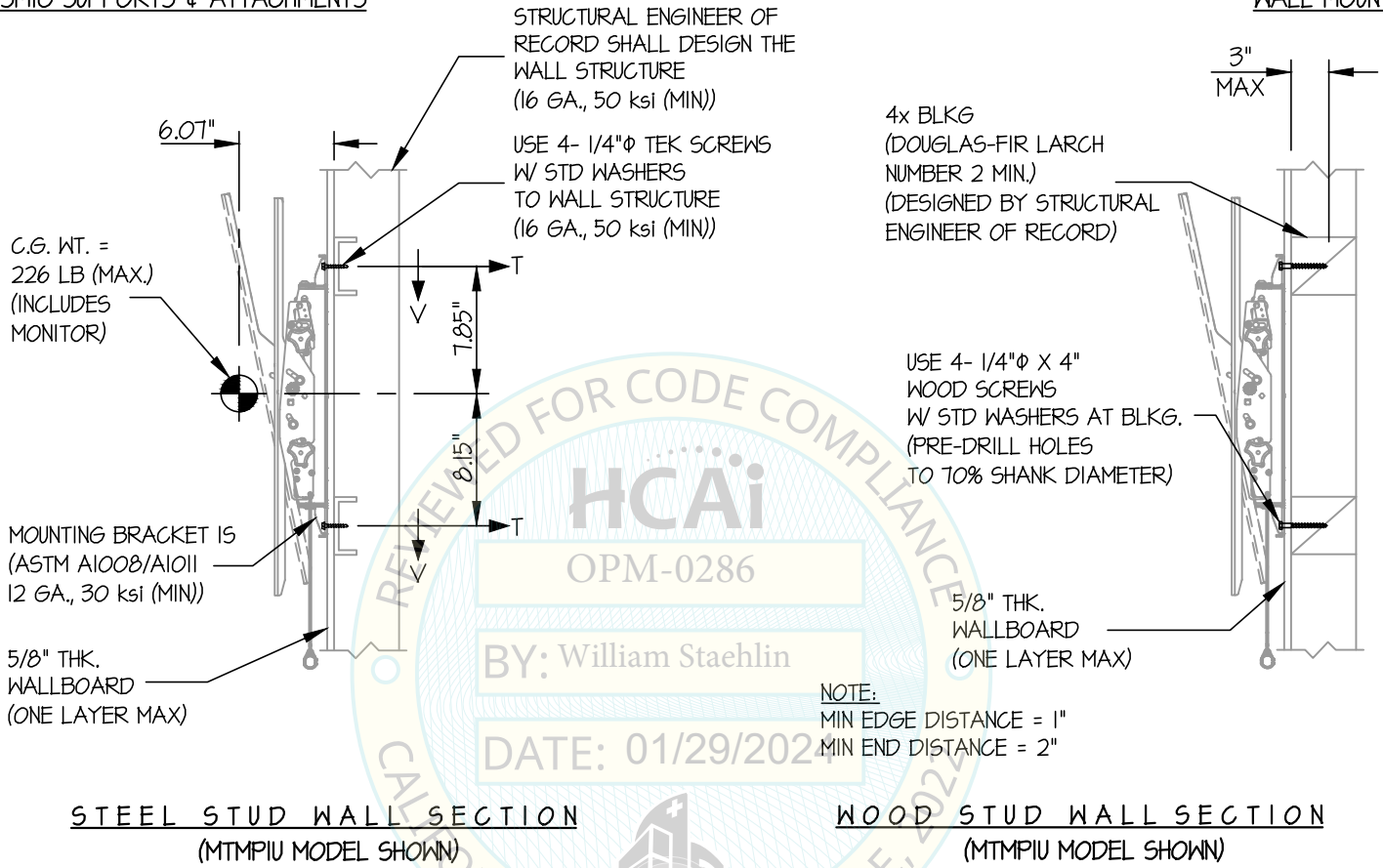

STEEL STUD WALL SECTION  
(MTMP1U MODEL SHOWN)

WOOD STUD WALL SECTION  
(MTMP1U MODEL SHOWN)

*Jonathan Roberson*  
REGISTERED PROFESSIONAL ENGINEER  
JONATHAN ROBERSON  
No. 4197  
EXP. 6-30-2024  
1/23/24  
STRUCTURAL  
STATE OF CALIFORNIA

**MILESTONE INC.**

DES. **J. ROBERSON**

SHEET

**5**

**MTMP1U SERIES  
MONITOR WALL MOUNT**

JOB NO. **11-2334**

DATE **1/23/24**

OF **6** SHEETS

SEISMIC SUPPORTS & ATTACHMENTS

WALL MOUNTED

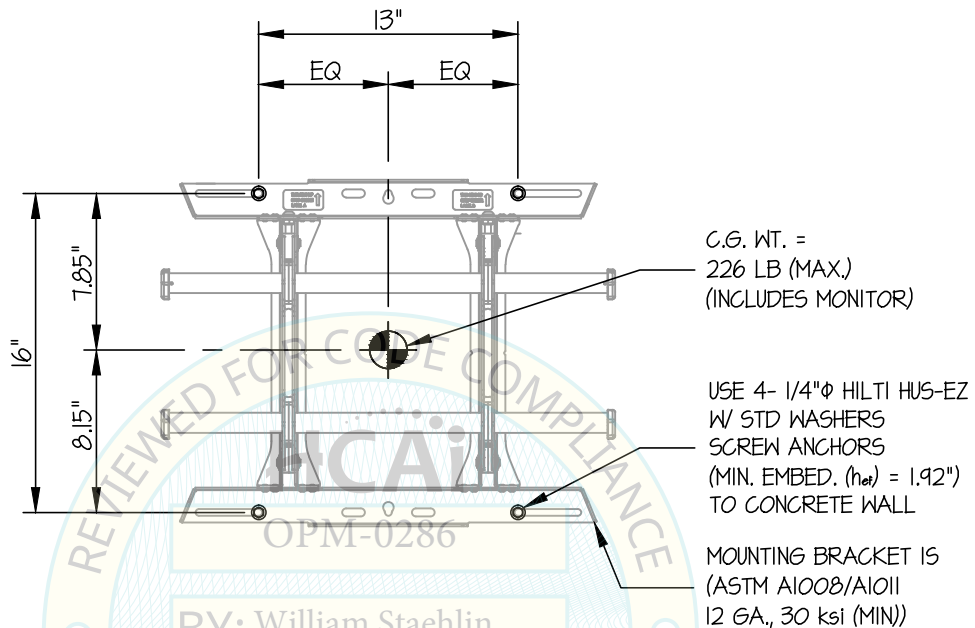

CONCRETE WALL  
T<sub>u</sub> = 270 LB/SCREW (MAX)  
V<sub>u</sub> = 344 LB/SCREW (MAX)  
(VALUES INCLUDE Ω)

ELEVATION AT WALL PLATE  
(MTMP1U MODEL SHOWN)

NOTES:

- FORCES ARE DETERMINED PER 2022 CALIFORNIA BUILDING CODE AND ASCE 7-16. STRENGTH DESIGN IS USED. (EXAMPLE: S<sub>ds</sub> = 2.00, a<sub>p</sub> = 1.0, I<sub>p</sub> = 1.5, R<sub>p</sub> = 2.5, Ω<sub>o</sub> = 2.0, z/h ≤ 1)

HORIZONTAL FORCE (E<sub>h</sub>) = 1.44 W<sub>p</sub>  
 HORIZONTAL FORCE (E<sub>mh</sub>) = 2.88 W<sub>p</sub> (FOR CONCRETE ANCHORAGE)  
 VERTICAL FORCE (E<sub>v</sub>) = 0.40 W<sub>p</sub>

- THIS PREAPPROVAL ENCOMPASSES WEIGHTS AND VERTICAL CG POSITIONS UP TO THE VALUES SHOWN.
- THIS PREAPPROVAL WAS PREPARED WITHOUT KNOWLEDGE OF ANY SITE CONDITION. COMPATIBILITY FOR USE WITH A SITE SHALL BE EVALUATED BY THE STRUCTURAL ENGINEER OF RECORD OF THE INSTALLATION (SEOR). USE REQUIRES APPROVAL BY THE SEOR.
- STRUCTURAL ENGINEER OF RECORD FOR THE INSTALLATION SHALL VERIFY ALL CONDITIONS, EVALUATE INTERACTION WITH ADJACENT EQUIPMENT AND ANCHORS, AND PROVIDE SUPPORT STRUCTURE DESIGNED TO SUPPORT WEIGHTS AND FORCES SHOWN IN COMBINATION WITH ALL OTHER LOADS THAT MAY BE PRESENT.

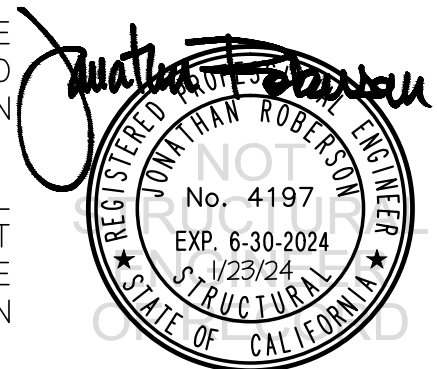

### MILESTONE INC.

DES. J. ROBERSON

SHEET

# 6

## MTMP1U SERIES MONITOR WALL MOUNT

JOB NO. 11-2334

DATE 1/23/24

OF 6 SHEETS

SEISMIC SUPPORTS & ATTACHMENTS

WALL MOUNTED

