



OFFICE OF STATEWIDE HEALTH PLANNING AND DEVELOPMENT
FACILITIES DEVELOPMENT DIVISION

APPLICATION FOR OSHPD PREAPPROVAL
OF MANUFACTURER'S CERTIFICATION (OPM)

OFFICE USE ONLY
APPLICATION #: OPM-0295-13

OSHPD Preapproval of Manufacturer's Certification (OPM)

Type: [X] New [] Renewal [] Update to Pre-CBC 2013 OPA Number:

Manufacturer Information

Manufacturer: Unistrut, a part of Atkore International
Manufacturer's Technical Representative: Jake Shaw
Mailing Address: 16100 S. Lathrop Ave., Harvey, IL 60426
Telephone: (708) 915-1727 Email: jshaw@atkore.com

Product Information

Product Name: Unistrut Seismic Bracing / Strut & Fittings
Product Type: Seismic Bracing and Support Systems
Product Model Number: Various
General Description: Supports, Attachments and Seismic Restraints for Suspended Distribution Systems

Applicant Information

Applicant Company Name: Unistrut, a part of Atkore International
Contact Person: Jake Shaw
Mailing Address: 16100 S. Lathrop Ave., Harvey, IL 60426
Telephone: (708) 915-1727 Email: jshaw@atkore.com

I hereby agree to reimburse the Office of Statewide Health Planning and Development review fees in accordance with the California Administrative Code, 2016.

Signature of Applicant: [Signature] Date: 17-Dec-2015
Title: Director of Marketing Company Name: Unistrut, a part of Atkore International

"Access to Safe, Quality Healthcare Environments that Meet California's Diverse and Dynamic Needs"





**OFFICE OF STATEWIDE HEALTH PLANNING AND DEVELOPMENT
FACILITIES DEVELOPMENT DIVISION**

Registered Design Professional Preparing Engineering Recommendations

Company Name: IDS Group, Inc.

Name: Rami Elhassan California License Number: S3930

Mailing Address: 1 Peters Canyon Road, Suite 130, Irvine, CA 92606

Telephone: (949) 387-8500 Email: Rami.Elhassan@idsgi.com

OSHPD Special Seismic Certification Preapproval (OSP)

- Special Seismic Certification is preapproved under OSP-
(Separate application for OSP is required)
- Special Seismic Certification is not preapproved

Certification Method(s)

- Testing in accordance with: ICC-ES AC156 FM 1950-15
- Other* (Please Specify): FM 1950-10

*Use of criteria other than those adopted by the California Building Standards Code, 2016 (CBSC 2016) for component supports and attachments are not permitted. For distribution system, interior partition wall, and suspended ceiling seismic bracings, test criteria other than those adopted in the CBSC 2016 may be used when approved by OSHPD prior to testing.

- Analysis
- Experience Data
- Combination of Testing, Analysis, and/or Experience Data (Please Specify): Many components and systems will be calculated and many will be tested in accordance with FM 1950-10.

List of Attachments Supporting the Manufacturer's Certification

- Test Report Drawings Calculations Manufacturer's Catalog
- Other(s) (Please Specify): _____

OFFICE USE ONLY – OSHPD APPROVAL VALID FOR CBC 2016 & ALL PRE-2016 CODE BASED PROJECTS

Signature: Date: 2/27/2020

Print Name: Jeffrey Kikumoto

Title: Structural Engineer

Condition of Approval (if applicable): _____

"Access to Safe, Quality Healthcare Environments that Meet California's Diverse and Dynamic Needs"



SEISMIC BRACING SOLUTIONS

OSHPD Pre-Approval

OPM-0295-13

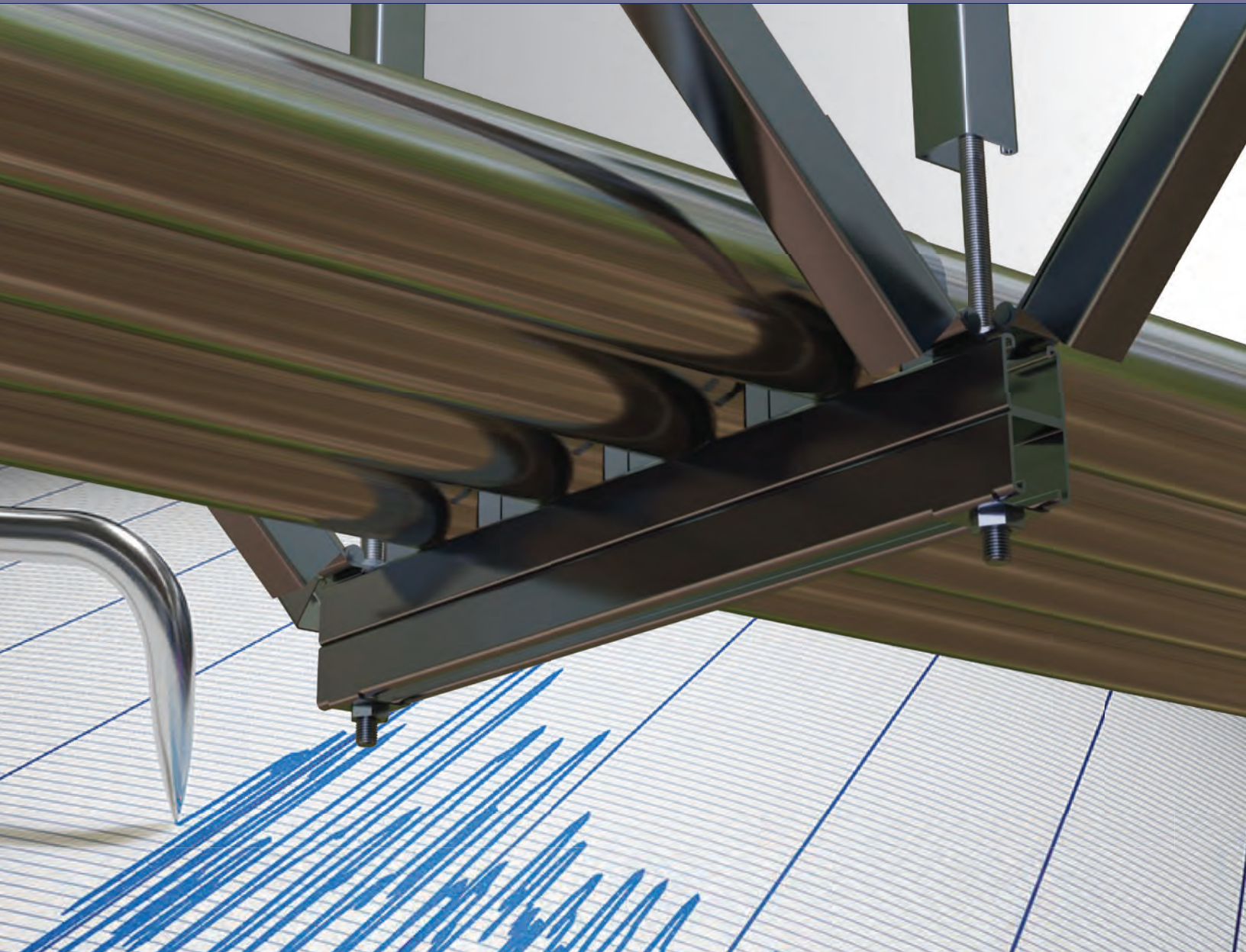

Atkore[™]
Unistrut

TABLE OF CONTENTS

1. General Notes

Abbreviations	1a.1
Glossary of Terms	1b.1
OPM Scope and Limitations	1c.1
Design Procedure / Flow Diagram	1d.1
Responsibilities of the Registered Design Professional / Structural Engineer of Record	1e.1
Drawings / Submittal Requirements	1f.1
General Notes	1g.1
Structural Post - Installed Expansion Anchors	1h.1 - 1h.4
System Notes	1i.1 - 1i.5
Material Notes	1j.1
Layout of Seismic Bracing Requirements	1k.1 - 1k.2
F_p/W_p Tables	1l.1 - 1l.4
Max Transverse (I_T) & Longitudinal (I_L) Brace Spacing Tables	1m.1 - 1m.3

2. Pre-Designed Solutions

Pre-Designed Solution Instructions	2a.1
Pre-Designed Solution Diagrams (Single Pipe, Conduit or Tube)	2b.1 - 2b.2
Pre-Designed Solutions (Schedule 10, 40 & 80 Steel Pipe)	2c.1 - 2c.3
Pre-Designed Solutions (No-Hub Cast Iron Steel Pipe)	2d.1 - 2d.3
Pre-Designed Solutions (Conduit - RMC & IMC)	2e.1 - 2e.3
Pre-Designed Solutions (Conduit - EMT)	2f.1 - 2f.3
Pre-Designed Solutions (Copper Pipe & Tube - Type K & L)	2g.1 - 2g.3
Pre-Designed Solution Diagrams (Trapeze Supported Pipe, Conduit, Cable Tray & Ductwork)	2h.1 - 2h.2
Pre-Designed Solutions (Trapeze Supported Pipe, Conduit, Cable Tray & Ductwork)	2i.1 - 2i.3

3. Restraint Methods

Restraint Details - Pipe, Conduit & Tube (Single)	3a.1 - 3a.2
Restraint Details - Pipe, Conduit & Tube (Trapeze)	3b.1 - 3b.2
Restraint Details - Rectangular Duct (Trapeze)	3c.1 - 3c.2
Restraint Details - Round Duct (Single)	3d.1 - 3d.2
Restraint Details - Cable Tray (Trapeze)	3e.1 - 3e.2



16100 S. Lathrop Ave
Harvey, IL 60426
Toll-Free: (800) 882-5543

www.unistrutseismic.com

Structural Engineer: Rami Elhassan
California SE No. 3930

Page:

i

Table of Contents

4. Components: Channel & Telespar

Channel - Rigid Braces.....	4a.1 - 4a.6
Telespar - Rigid Braces.....	4a.7
Channel - Beam Loading.....	4b.0 - 4b.6
Channel Section Properties.....	4c.1

5. Components: Fittings, Pipe & Conduit Clamps and Wolf Washer

Typical Connection Details.....	5a.1 - 5a.8
Wolf Washer & Square Washers	5b.1 - 5b.2
Brace Fittings.....	5c.1 - 5c.5
Pipe, Conduit & Tube Clamps	5d.1 - 5d.4
Cable Tray Supports	5e.1

6. Components: Channel Nuts & Hardware

Channel Nuts.....	6a.1
Break-Off Head Bolt	6b.1
General Hardware	6c.1 - 6c.2
Rod Stiffeners.....	6d.1 - 6d.3

7. Connections / Anchors

Post- Installed Concrete Connections.....	7a.1 - 7a.2
Post- Installed Concrete Filled Metal Deck Connections.....	7b.1 - 7b.2
Steel Beam Connections	7c.1 - 7c.2
Wood Beam Connections.....	7d.1 - 7d.2

8. Design Examples

Single Pipe Seismic Restraint Design Example.....	8a.1 - 8a.6
Trapeze Supported Component(s) Seismic Restraint Design Example.....	8b.1 - 8b.7
Round Duct Seismic Restraint Design Example.....	8c.1 - 8c.5

Appendix

System Self Weight Tables.....	A1.1 - A1.9
--------------------------------	-------------

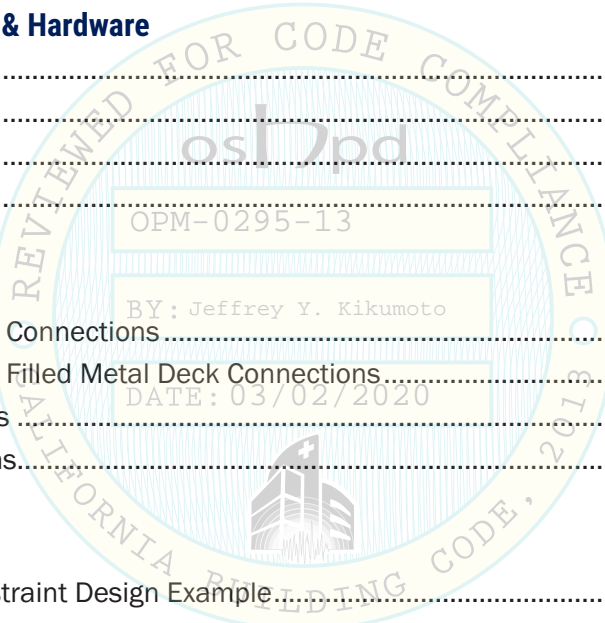

16100 S. Lathrop Ave
Harvey, IL 60426
Toll-Free: (800) 882-5543

www.unistrutseismic.com

Structural Engineer: Rami Elhassan
California SE No. 3930

Page:

ii

Abbreviations

ASCE – American Society of Civil Engineers

CBC – California Building Code

C_L – Longitudinal Capacity

C_T – Transverse Capacity

C_V – Vertical Capacity

D_{allow} – Maximum allowable uniform load of channel (lbs), as limited by deflection

DIA. (Ø) – Diameter

EMT – Electrical Metal Tubing

ft. (') – Foot; Feet

G_{allow} – Maximum allowable uniform load of beam (lbs), accounting for channel capacities and load & support conditions

ga. – Gauge

IMC – Intermediate Metal Conduit

In (") – Inch

lbs. (#) – Pounds

l_L – Longitudinal brace spacing

l_T – Transverse brace spacing

l_V – Support spacing

LWC – Light Weight Concrete. LWC in this OPM is taken to be Sand-Lightweight Concrete.

M_{allow} – Maximum allowable moment of channel (in-lbs), as limited by strength.

MFR – Manufacturer

NEMA – National Electrical Manufacturer's Association

NWC – Normal Weight Concrete

OSHPD – Office of Statewide Health Planning and Development

Φ_{LV} – Maximum unbraced length factor

RDP – Registered Design Professional

RMC – Rigid Metal Conduit. Also known as Galvanized Rigid Conduit (GRC).

SEOR – Structural Engineer of Record

SMS – Sheet Metal Screw

U.N.O. – Unless Noted Otherwise

V_{allow} – Maximum allowable uniform load of channel (lbs), as limited by strength.

$W_{channel}$ – Weight of channel (lbs) at a determined length.

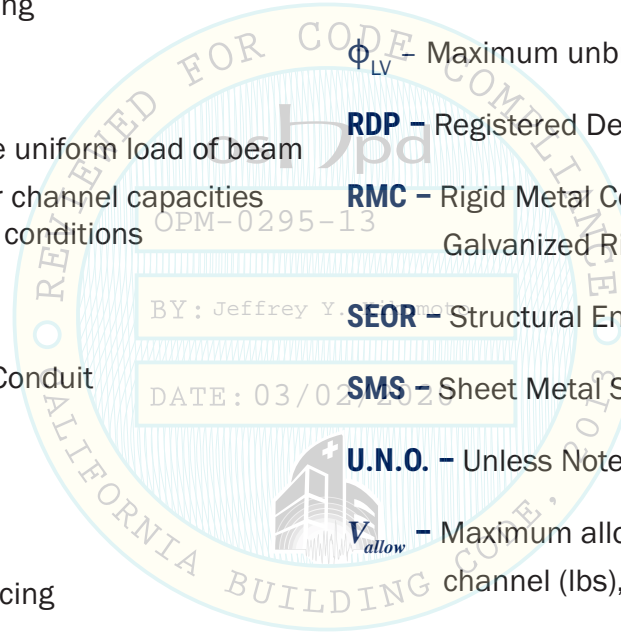

Atkore
Unistrut

16100 S. Lathrop Ave
Harvey, IL 60426
Toll-Free: (800) 882-5543

www.unistrutseismic.com

Structural Engineer: Rami Elhassan
California SE No. 3930

Page:

1a.1

Glossary of Terms

ASD – Allowable Stress Design; a method of proportioning structural members such that elastically computed stresses produced in the members by nominal loads do not exceed specified allowable stresses.

Design Load (Capacity) – Allowable Strength Design (ASD) capacity obtained by LRFD capacity divided by 1.5 in accordance with FM 1950-10.

F_p – Horizontal Seismic Force; applies to the center of gravity and distributed relative to the component's mass distribution.

Grade – Ground level of building; referred to as 0'- 0" elevation.

Lateral Brace – A generic term used to describe a brace that resists lateral forces in the longitudinal or transverse direction.

Longitudinal – Direction along or parallel to the horizontal axis of a component or element's run.

LRFD – Load and Resistance Factor Design; a method of proportioning structural members such that the computed forces produced in the members by the factored loads do not exceed the member design strength.

Run – Direction of pipe layout, along the axis of the pipe.

Snug Tight – Tightness required to bring the connected plies into firm contact, and that the nuts could not be removed without the use of a wrench.

Strength Design – For load and resistance factor design; ultimate load (design for most critical effects of loads).

Sway Brace – A mechanical device used for resisting lateral forces.

Transverse – Direction perpendicular to the horizontal of a component or element's run.

Trapeze- Part of an assembly used to help resist seismic forces.

Working Stress – Allowable load used for design; factors down strength design loads, providing a safety factor. Generally, strength design forces divided by a factor of 1.4.

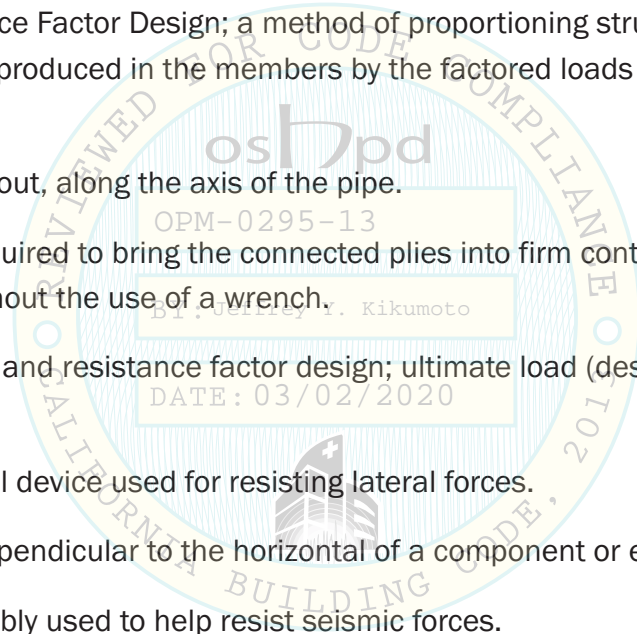

 <p style="text-align: center;">www.unistrutseismic.com</p>	<p>16100 S. Lathrop Ave Harvey, IL 60426 Toll-Free: (800) 882-5543</p>		Page:
		<p>Structural Engineer: Rami Elhassan California SE No. 3930</p>	1b.1

OPM Scope and Limitations

This OSHPD Preapproval of Manufacturer's Certification (OPM) is based on the CBC 2013. The demand (design forces) for use with this OPM shall be based on the CBC 2013.

The following OPM document defines the required seismic bracing for pipe, ductwork, conduit, and cable tray. It does not address components that cross seismic separations of buildings, or components attached to portions of the structure or equipment that will experience relative seismic displacement.

The following OPM is for indoor components only, where the design is controlled by seismic forces. Components that are subject to significant non-seismic forces such as, but not limited to, gravity (where seismic force is primarily vertical seismic force produced by self-weight of the components supported), wind, flood, snow, soil, water pressure, fluid dynamics, pipe rupture, movement of equipment, vibration, or thermal growth are not included in the scope of this OPM document.

This OPM applies only to Unistrut® brand products.

Please see the following Overview outlining the design criteria for this OPM document.

Overview

Section 1 – General Requirements: Includes the Design Procedure/Flow Diagram, Responsibilities of the Registered Design Professional (RDP)/ Structural Engineer of Record (SEOR), Drawings/Submittal Requirements, General Notes, Systems Notes, Material Notes, Layout of Seismic Bracing Requirements, F_p / W_p Tables, Structural Post-Installed Expansion Anchors, and Design Examples.

Section 2 – Single Component Bracing Pre-Designs: Includes bracing designs for specific F_p forces for single supported components.

Section 3 – Typical Bracing Configuration: Includes typical rigid bracing configurations for single components and multiple components supported by a trapeze. References to other applicable sections for each part of the lateral brace configuration are shown.

Section 4 – Allowable Channel Capacities: Provides the maximum horizontal seismic F_p force for each type of channel, length of channel, and brace angle. This section also includes the maximum horizontal seismic F_p for channel used as a beam within a trapeze.

Section 5 – Allowable Fitting Capacities: Specifies the maximum horizontal seismic F_p force for each type of fitting.

Section 6 – Allowable Hardware Capacities: Specifies the maximum horizontal seismic F_p force for each type of hardware.

Section 7 – Allowable Structural Attachment Capacities: Specifies the maximum horizontal seismic F_p force for each connection to each material included in the OPM at specific brace angles.

Appendices

Includes supporting documentation.

Atkore
Unistrut

16100 S. Lathrop Ave
Harvey, IL 60426
Toll-Free: (800) 882-5543

www.unistrutseismic.com



Structural Engineer: Rami Elhassan
California SE No. 3930

Page:

1c.1

Design Procedure / Flow Diagram

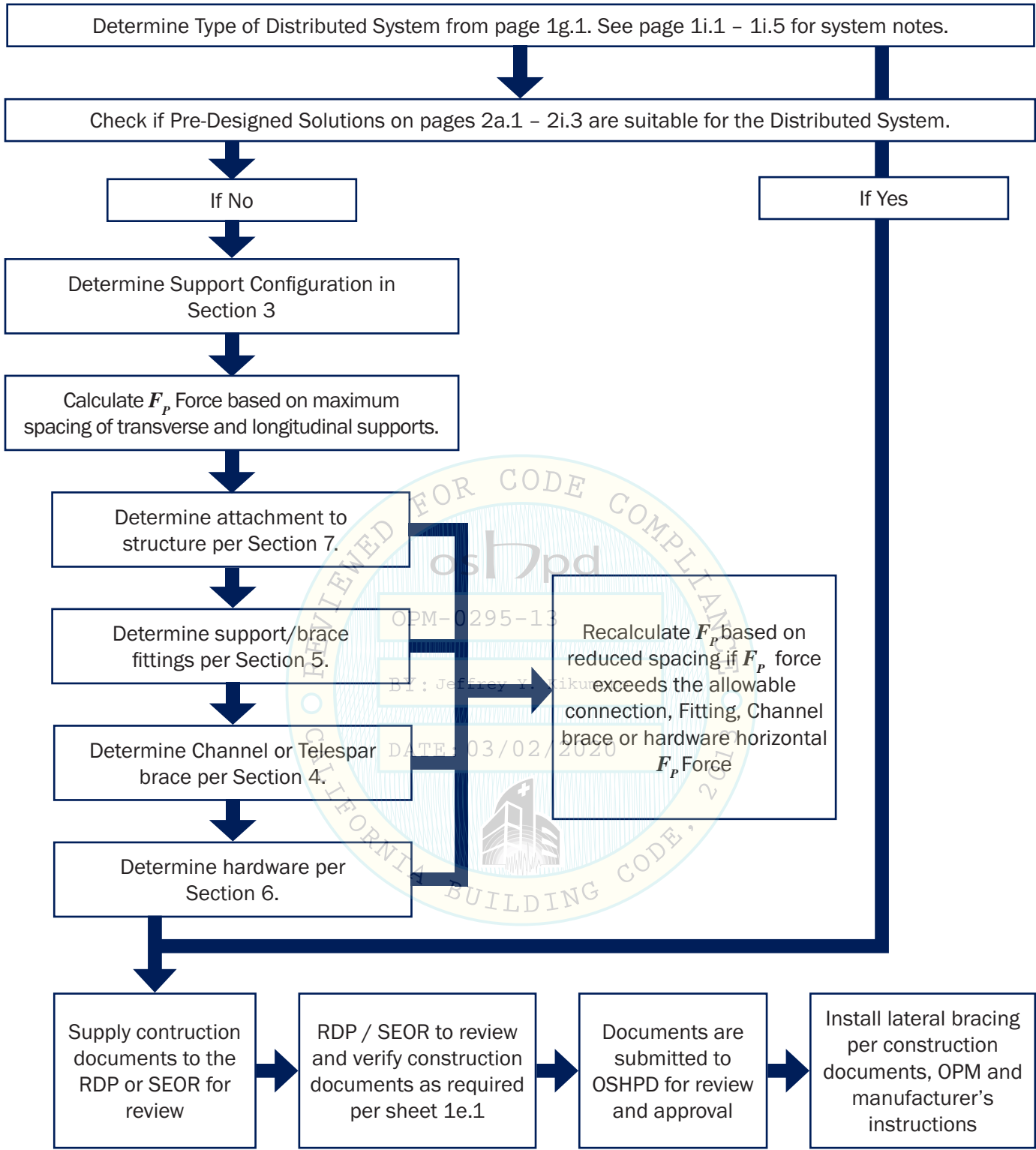

Atkore
Unistrut

16100 S. Lathrop Ave
Harvey, IL 60426
Toll-Free: (800) 882-5543

www.unistrutseismic.com

Rami Elhassan

Structural Engineer: Rami Elhassan
California SE No. 3930

Page:

1d.1

Responsibilities of the Registered Design Professional / Structural Engineer of Record

The Registered Design Professional (RDP) is the engineer executing the design of the seismic bracing system. The RDP delivers the complete seismic bracing design to the Structural Engineer of Record (SEOR) for the OSHPD project.

1. It is the responsibility of the RDP to be familiar with all requirements for seismic bracing.
2. The Registered Design Professional shall:
 - A. Verify the adequacy of the structure (such as floors, beams, walls, etc.) which support/brace the distributed system for the loads/forces imposed on them by the distributed system as well as all other loads.
 - B. Provide any supporting structure required to support/brace the forces, in addition to all other loads. The design of any required supporting structure shall be submitted to OSHPD as part of the original construction documents, or as a deferred submittal item; deferred submittal items shall be listed on the cover page of the original construction documents.
 - C. Verify that the installation is in conformance with the 2013 California Building Code and with the details shown in this pre-approval. Verify that the brace locations, braces, components, fittings, hardware, building connections, and materials match the information shown on this pre-approval document.
 - D. The RDP shall select the proper products from this OPM based on the combined effects. For Hangers, and their associated hardware, fittings, and structural attachment, designers shall also calculate the gravity forces (dead load and vertical seismic forces), and the combined effects with lateral and overturning forces as required per the governing code.
3. The RDP shall determine the spacing and layout for the required bracing. The user shall determine the maximum horizontal, vertical, and axial force component of earthquake demand loads. The RDP's calculations must take into consideration the increase in loads caused by construction tolerances.
4. The SEOR shall verify that the supporting structure is adequate for the forces imposed on it by the supports, attachments, and braces installed in accordance with the pre-approval in addition to all other loads.
5. The SEOR shall forward the supports, attachments, and bracing drawings (including approved amended construction documents for supplementary framing (where required) to the discipline in responsible charge with a notation indicating that the drawings have been reviewed and are in general conformance with the preapproval and the design of the project.
6. The SEOR shall verify the substrate to which the seismic brace components are attached meet the requirements of the approved evaluation reports (ERs). Testing of post-installed anchors shall be performed in accordance with the 2013 CBC §1913A.7.

 <p style="text-align: center;">16100 S. Lathrop Ave Harvey, IL 60426 Toll-Free: (800) 882-5543</p> <p style="text-align: center;">www.unistrutseismic.com</p>	 Structural Engineer: Rami Elhassan California SE No. 3930	Page: <h1 style="text-align: center; margin: 0;">1e.1</h1>

Drawings / Submittal Requirements

1. Construction Documents are required and shall include how and where the support, attachment, and bracing system will be applied for the specific project based upon this pre-approval. This process is used to verify that the design has been determined and documented for each condition in the project.
2. Construction Documents shall include the locations and spacing of the supports, attachments, and bracing systems in accordance with the pre-approval. The layout drawings shall, as a minimum, satisfy the requirements of ASCE 7 Section 13.6 (including Supplements #1 and #2).
3. Seismic bracing design and layout drawings shall be either prepared by a RDP licensed in California with experience in the design of seismic bracing of the specific system, or prepared by a qualified engineer with experience in the design of seismic bracing for the specific system and reviewed, stamped and signed by a RDP licensed in California with experience in the design of the seismic bracing for the specific system.
4. The RDP, other than SEOR, may provide the shop drawing stamp for small projects at the discretion of OSHPD.
5. Modifications and/or changes to the designs shown in this guideline shall be performed or reviewed by a qualified Registered Structural Engineer and approved by OSHPD.
6. Refer to OSHPD Policy Intent Notice (PIN) 62, item #11 for instructions and requirements of the SEOR and RDP.

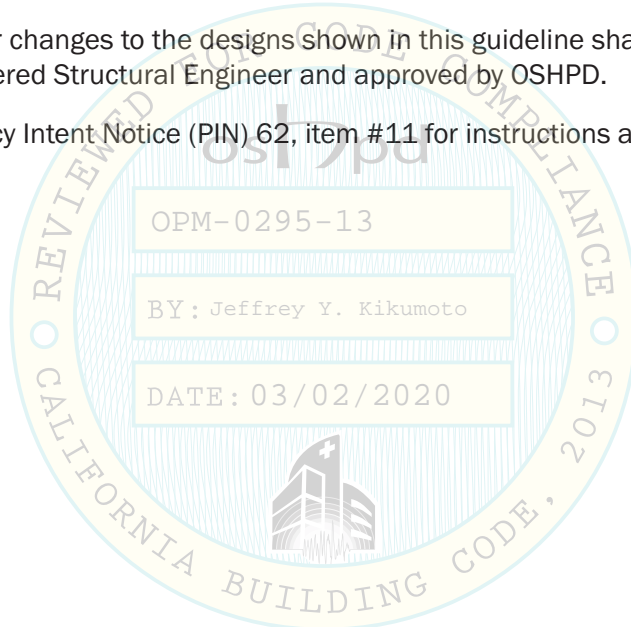

 <p style="text-align: center;"> 16100 S. Lathrop Ave Harvey, IL 60426 Toll-Free: (800) 882-5543 www.unistrutseismic.com </p>	 Structural Engineer: Rami Elhassan California SE No. 3930	Page: <h1 style="text-align: center;">1f.1</h1>
	<p>OSHPD</p>	

General Notes

1. This OSHPD Preapproval of Manufacturer's Certification (OPM) is based on the CBC 2013. The demand (design Force) for use with this OPM shall be based on the CBC 2013.
2. The maximum S_{DS} used in this OPM is 2.5 for projects in California. The limits of this OPM are force based, controlled by an allowable Maximum Horizontal F_p force.
3. The materials for each component type and the range of sizes for each material is as follows:

Pipe:

- A. Steel (Schedule 10) – Pipe sizes up to 8" diameter
- B. Steel (Schedule 40) – Pipe sizes up to 8" diameter
- C. Steel (Schedule 80) – Pipe sizes up to 8" diameter
- D. Copper (Type L) – Pipe sizes up to 4" diameter
- E. Copper (Type K) – Pipe sizes up to 4" diameter
- F. Copper (Type M) – Pipe sizes up to 4" diameter
- G. Cast-Iron Hub-less – Pipe sizes up to 8" diameter

Ductwork:

- A. Galvanized Rectangular Ducts: All Sizes
- B. Galvanized Round Ducts: 3" to 84"

Conduit:

- A. RMC Conduit - Sizes up to 6"
- B. IMC Conduit - Sizes up to 4"
- C. EMT Conduit - Sizes up to 4"

Cable Tray:

- A. NEMA (VE-1) – Class A, B, and C
- B. Power Cables – 6" through 36" Wide
- C. Low Voltage/ Data/ Communication – 6" Wide through 36" Wide

4. The structure substrate materials included in this OPM:
 - A. Normal Weight Concrete Slabs – 4 1/4" minimum thickness
 - B. Sand Light Weight Concrete over W3 Metal Deck – 3 1/4" minimum thickness over metal deck
 - C. Steel Framing
 - D. Wood Framing – 4x6 minimum framing size

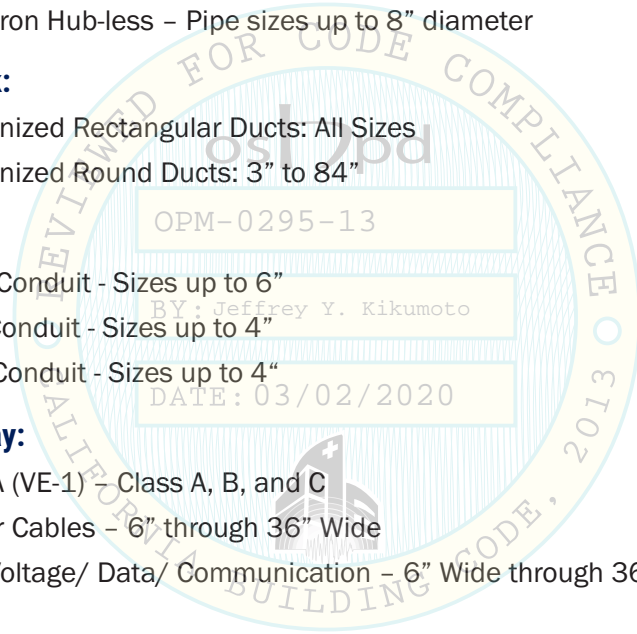

16100 S. Lathrop Ave
Harvey, IL 60426
Toll-Free: (800) 882-5543

www.unistrutseismic.com

Structural Engineer: Rami Elhassan
California SE No. 3930

Page:

1g.1

Structural Post-Installed Expansion Anchors

Structural Post-Installed Expansion Anchors General Notes

1. Approved post-installed expansion anchors and ICC-ES Reports:
 - I. Powers Power-Stud+ SD2 - ESR-2502
 - II. Simpson Strong-Tie Strong Bolt 2 (SB2) - ESR-3037
 - III. ITW Red Head Carbon Steel Trubolt+ Wedge Anchor - ESR-2427
 - IV. Hilti Kwik Bolt TZ (KBTZ) - ESR-1917
2. Anchor embedment depths are shown on Page 1h.2 and are the minimum required to meet the specific loading requirements. See Diagram on Page 1h.3 for nomenclature.
3. Allowable strengths shall be compared to all allowable stress design (ASD) level demand in accordance with ASCE 7-10 Section 12.4, 2013 California Building Code Section 1605A.3.1. Allowable strengths are for single anchors which meet min. requirements per tables on page 1h.4. as determined by strength design calculations per Section 1909A.
4. Minimum concrete strength $f'c = 3,000$ psi.
5. Post-installed anchors shall not be used in pre-stressed concrete unless non-destructive testing methods are used to locate strands and reinforcing prior to anchor installation.
6. Post-installed anchor installation shall not nick or damage existing reinforcement. Should this occur, the RDP responsible in charge shall be notified immediately. Expansion anchors shall be installed 1" clear of existing reinforcement.
7. All post-installed anchor values are for cracked concrete and include 0.75 reduction based on ACI 318-11 D3.3.3 requirements, and using an alpha factor of 1.4. All values in tables are for cracked concrete & include reduction based on ACI 318-11 D3.3.4 requirements. The allowable strengths are based upon the least of the allowable strengths calculated using the ICC ESRs 1917, 2427, 2502, & 3037 and using an α factor of 1.4.
8. Expansion anchors installed through upper or lower flutes of metal deck shall meet the requirements of the installation criteria and section below. Steel deck to be min. 20 ga. W-Deck. Minimum concrete fill depth above the top of metal deck per section and installation criteria below.
9. Post-installed anchor finish shall be determined by the end user. If unknown, provide stainless steel anchors.
10. Shall have special inspection and testing in accordance with the 2013 California Building Code Sections 1704A.2, 1705A.3, and 1913A.7. For qualification, design and use of post-installed anchors in concrete, see the 2013 CBC sections 1616a.1.19 and 1908A.1.1 listing of current ICC-ES evaluation reports (or reports from other testing agencies acceptable to OSHPD) shall be required for fasteners used.

Atkore
Unistrut

16100 S. Lathrop Ave
Harvey, IL 60426
Toll-Free: (800) 882-5543

www.unistrutseismic.com

Structural Engineer: Rami Elhassan
California SE No. 3930

Page:

1h.1

Structural Post-Installed Expansion Anchors

Structural Post-Installed Expansion Anchors General Notes Continued

11. All (100%) of the post-installed anchors shall be tested. Testing shall be witnessed and reported by the inspector of record (IOR) or special inspector and report of test results shall be submitted to OSHPD. Testing of expansion anchors shall be per 2013 CBC Section 1913A.7.
12. Test acceptance (for torque controlled anchors only) is by reaching the torque within "1/2 turn of the nut" ("1/4 turn of the nut" for 3/8" diameter expansion anchors) or maintaining the test load for at least 15 seconds and shall exhibit no discernible movement for tension test.
13. If stainless steel anchors are required by the owner/end user, utilize manufacturer's comparable product with tensions/torque test (torque test is limited to torque controlled anchors only).
14. Mechanical concrete anchor shall comply with OSHPD approved Construction Documents if this OPM is used as a deferred submittal (DSI package).
15. Expansion anchors shall be installed per current ICC-ES evaluation report.
16. Expansion anchors shall be installed to comply w/ the minimum slab thickness requirements established by the ICC-ESR for the specified anchor.
17. Avoid damaging existing steel reinforcing in concrete slab/wall when installing concrete expansion anchors.
18. Provide for full thread engagement of nut and washer.

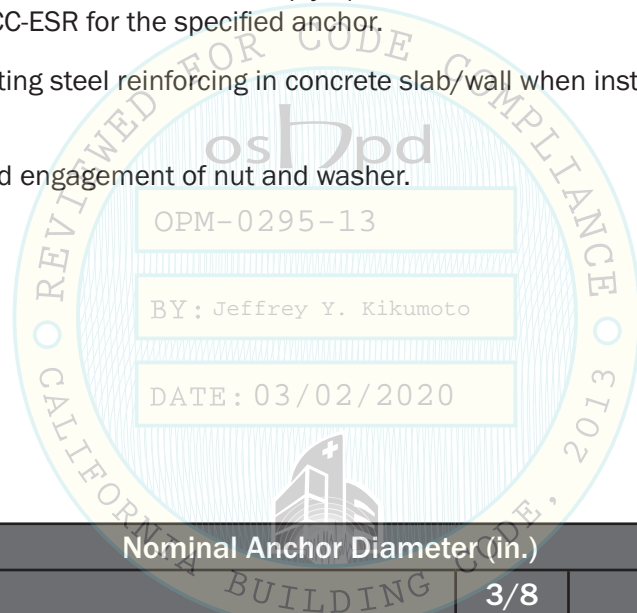

	Nominal Anchor Diameter (in.)				
	3/8	1/2		5/8	
Effective Min. Embedment (in.)	2	2¼	3¼	3⅝	4
Min. Member Thickness NWC Slab or Beam Only (in.)	4½	4½	6	6	7¼
Min. Anchor Spacing (3 x Embed) (in.)	6¾	6¾	9¾	9⅝	12
Min. Edge Distance (in.)	6	7	7½	6½	8¾

16100 S. Lathrop Ave Harvey, IL 60426 Toll-Free: (800) 882-5543 www.unistrutseismic.com	Structural Engineer: Rami Elhassan California SE No. 3930	Page: <h1 style="margin: 0;">1h.2</h1>
	www.unistrutseismic.com	

Structural Post-Installed Expansion Anchors

Carbon Steel Mechanical Concrete Anchors (Expansion Anchors)

Anchor Manufacturer & Type	Anchor Size (Dia.)	h_{ef}	h_{nom}	h_o	h_{min}^1	Minimum Edge Distance	Minimum Spacing	Intallation & Testing Torque	Tension Testing Load (lbs.)	
	(in)	(in)	(in)	(in)	(in)	(in)	(in)	(ft-lbs)	Slab or Beam	Composite Deck
Powers Fasteners SD2 ESR-2502	3/8	2	2 3/8	2 5/8	4	4	4	20	1,922	1,208
	1/2	2 1/4	2 1/2	2 3/4	4 1/2	4 1/2	4 1/2	40	2,202	1,220
		3 1/4	3 3/4	4	5 3/4	5 3/4	5 3/4		4,006	2,172
	5/8	3 1/4	3 7/8	4 1/4	5 3/4	5 3/4	5 3/4	60	4,300	1,672
		4 1/4	4 7/8	5 1/4	6 1/2	6 1/2	6 1/2		6,226	3,882
ITW Red Head Trubolt+ ESR-2427	3/8	2	2	2 1/4	4	4	4	30	1,922	1,208
	1/2	2 1/4	2 1/2	2 3/4	4	4	4	45	2,202	1,220
		3 1/4	3 3/4	4	6	6	6		4,006	2,172
	5/8	3 1/4	3 1/4	3 1/2	6	6	6	90	4,300	1,672
		4 1/4	4 3/4	5	6 1/4	6 1/4	6 1/4		6,226	3,882
Simpson Strong-Tie SB2 ESR-3037	3/8	2	1 7/8	2	3 1/4	3 1/4	3 1/4	30	1,922	1,208
	1/2	2 1/4	2 3/4	3	4 1/2	4 1/2	4 1/2	60	2,202	1,220
		3 3/8	3 7/8	4 1/8	6	6	6		4,006	2,172
	5/8	3 1/4	3 3/8	3 5/8	5 1/2	5 1/2	5 1/2	90	4,300	1,672
		4 1/2	5 1/8	5 3/8	7 7/8	7 7/8	7 7/8		6,226	3,882
Hilti KBTZ ESR-1917	3/8	2	2 5/16	2 5/8	4	4	4	25	1,922	1,208
	1/2	2 1/4	2 3/8	2 5/8	4	4	4	40	2,202	1,220
		3 1/4	3 5/8	4	6	6	6		4,006	2,172
	5/8	3 1/4	3 3/8	3 3/4	5	5	5	60	4,300	1,672
		4 1/4	4 7/16	4 3/4	6	6	6		6,226	3,882

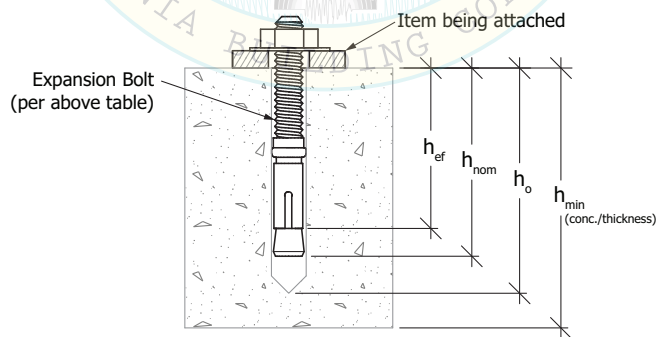

Notes:

- 1) h_{min} applies to solid slab sections and topside of concrete metal deck sections.

Atkore
Unistrut

16100 S. Lathrop Ave
Harvey, IL 60426
Toll-Free: (800) 882-5543

www.unistrutseismic.com

Rami Elhassan
Structural Engineer: Rami Elhassan
California SE No. 3930

Page:

1h.3

Structural Post-Installed Expansion Anchors

EXPANSION ANCHOR INSTALLATION CRITERIA

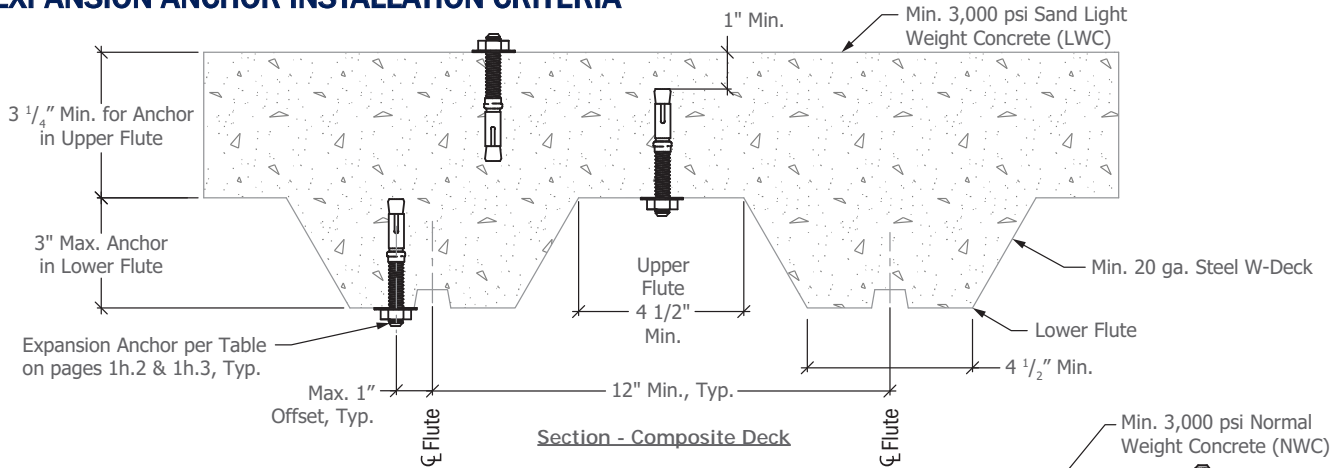

EXPANSION ANCHOR ALLOWABLE STRENGTHS

Table 1:

Expansion anchors installed in to the underside of structural sand-lightweight concrete ($f'c$ min = 3,000 psi) over metal deck. See composite section above.

Anchor Dia. (in.)	Embed (h _{ef}) (in.)	Shear (lbs.)	Tension (lbs.)
3/8	2	747	604
1/2	2 1/4	1,029	610
1/2 *	3 1/4	1,173	1,086
5/8 *	3 1/4	1,353	836
5/8 *	4 1/4	2,477	1,941

*Lower flute installation

Table 2:

Expansion anchors installed in to the top of structural sand-lightweight concrete ($f'c$ min = 3,000 psi) over metal deck. See composite section above.

Anchor Dia. (in.)	Embed (h _{ef}) (in.)	Shear (lbs.)	Tension (lbs.)
3/8	2	806	624
1/2	2 1/4	948	660

Notes:

- 1) These values are for use with load combinations with overstrength factor and have been increased by 20% in accordance with ASCE 7-10, Section 12.4.3.3.
- 2) Anchor spacing requirements along the flute: Greater of (3 x h_{ef}) or (1.5 x Flute Width).

Min. Member Thickness per Installation Criteria on pages 1h.2 & 1h.3

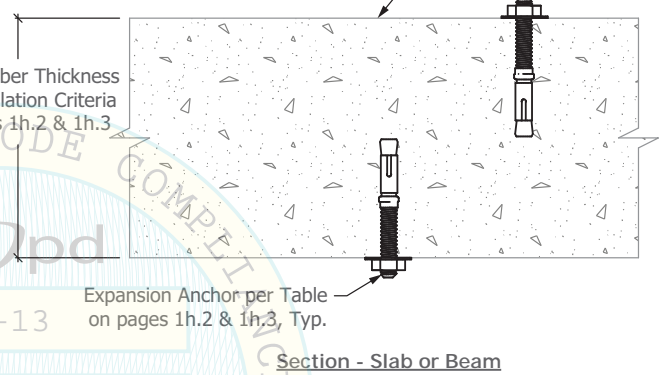

Table 3:

Expansion anchors installed in normal weight concrete ($f'c$ min = 3,000 psi). See slab/bm section above.

Anchor Dia. (in.)	Embed (h _{ef}) (in.)	Shear (lbs.)	Tension (lbs.)
3/8	2	1,020	961
1/2	2 1/4	1,580	1,101
1/2	3 1/4	2,591	2,003
5/8	3 1/4	2,579	2,150
5/8	4 1/4	3,772	3,113



16100 S. Lathrop Ave
Harvey, IL 60426
Toll-Free: (800) 882-5543

www.unistrutseismic.com

Rami Elhassan

Structural Engineer: Rami Elhassan
California SE No. 3930

Page:

1h.4

System Notes

SYSTEM NOTES:

1. This OSHPD Preapproval of Manufacturer's Certification (OPM) is based upon the 2013 CBC. The demand (design forces) for use with this OPM shall be based on the CBC 2013.
2. This OPM is limited to ductwork, piping, conduit and cable tray systems specifically included herein.
3. This OPM is intended to address restraint of suspended distributed systems not qualifying for the exceptions noted in 2013 CBC 1616A.1.18 noted below.

Replace ASCE 7, Section 13.1.4, with the following:

13.1.4 Exemptions. The following nonstructural components are exempt from the requirements of this section:

3. Architectural, mechanical and electrical components in Seismic Design Categories D, E or F where all of the following apply:

- a. The component is positively attached to the structure;
- b. Flexible connections are provided at seismic separation joints and between the component and associated ductwork, piping, conduit and cable tray; and either:
 - i. The component weighs 400 pounds (1,780 N) or less and has a center of mass located 4 feet (1.22 m) or less above the adjacent floor or roof level that directly support the component;

Exception: Special Seismic Certification requirements of this code in accordance with Section 1705A.12.3 shall be applicable

or

- ii. The component weighs 20 pounds (89 N) or less or, in the case of a distributed system, 5 lbs./ ft. (73N/m) or less.

Exception: The enforcement agency shall be permitted to require attachments for equipment with hazardous contents to be shown on construction documents irrespective of weight.

Atkore[™]
Unistrut

16100 S. Lathrop Ave
Harvey, IL 60426
Toll-Free: (800) 882-5543

www.unistrutseismic.com

Structural Engineer: Rami Elhassan
California SE No. 3930

Page:

1i.1

System Notes

4. Per ASCE 7-10, Section 13.3.1, restraints and their anchorages must be capable of restraining horizontal, F_p , and vertical, E_v , seismic forces as follows.

$$F_p = (0.7) \frac{0.4 a_p S_{DS} W_p}{R_p / I_p} \left(1 + 2 \frac{z}{h} \right) \quad (\text{ASD}) \quad (\text{ASCE 7-10 EQ 13.3-1})$$

is not required to be taken greater than $(0.7) 1.6 S_{DS} I_p W_p$ (ASD) (ASCE 7-10 EQ 13.3-2)

shall not be taken less than $(0.7) 0.3 S_{DS} I_p W_p$ (ASD) (ASCE 7-10 EQ 13.3-3)

$$E_{v\text{ASD}} = \pm (0.7) 0.2 S_{DS} W_p \quad (\text{ASD}) \quad (\text{ASCE 7-10 Section 13.3.1})$$

Where:

S_{DS} = Spectral acceleration, short period, as determined per ASCE 7-10, Section 11.4.4. This value is typically located on OSHPD approved structural design drawings related to the project and will take precedence over those calculated in ASCE 7-10, Section 11.4.4. S_{DS} shall not exceed 2.5.

W_p = component (system unit) operating weight (lbs./ft.). Typical weights are located in Appendix A1.

I_p = component (system) importance factor shall be taken as 1.5 for systems covered under this OPM. Site specific licensed engineered design may be used to adjust the I_p down where appropriate.

a_p = component amplification factor as shown on Page 1i.5 (Ref. ASCE 7-10, Table 13.6-1).

R_p = component response modification factor as shown on Page 1i.5 (Ref. ASCE 7-10, Table 13.6-1). Per ASCE 7-10, Section 13.4.1, R_p shall not exceed 6 when determining the design forces (F_p & E_v) in the attachment.

z = height in structure of point of connection to the building of component with respect to base (ft. or stories). In most cases this shall be taken as the floor/roof framing above the area of work.

h = average roof height of structure with respect to base (ft. or stories). If unsure as to the proper z/h ratio, a value of 1 (or 100%) representing the maximum height in the building (and worst case scenario) can be taken as a conservative value.

Ω_0 = overstrength factor as required for anchorage to concrete (see page 1i.5).

5. For systems **anchored to concrete only**, the anchorage to concrete overstrength factor, Ω_0 , as found on Page 1i.5 (Ref. ASCE 7-10 Table 13.6-1), must be applied to horizontal forces F_p (and any resulting vertical force components). Concrete Ω_0 **need not apply** to E_v forces; however, to simplify the use of this document, Ω_0 has been applied to the allowable capacity for concrete anchors when subject to F_p forces.

6. The weakest component for each direction within each lateral restraint location determines the restraint capacity.

7. Cast iron pipe (no-hub pipe) brace spacings shall not exceed the spacings tabulated on page 1m.3. No-hub couplings shall be manufactured in accordance with ASTM C1540, shall be certified in accordance with FM 1680 Class 1 and gravity hangers shall be spaced per the requirements of Table 313.1 of the 2013 California Plumbing Code (CPC 2013) for no-hub cast iron pipe.

Exception: Cast iron (no-hub) pipe joined by couplings not satisfying ASTM C1540 or not certified in accordance with FM 1680 Class 1 shall be designed on a project by project basis, and shall require project specific OSHPD approval.

Atkore
Unistrut

16100 S. Lathrop Ave
Harvey, IL 60426
Toll-Free: (800) 882-5543

www.unistrutseismic.com

Structural Engineer: Rami Elhassan
California SE No. 3930

Page:

1i.2

System Notes

8. The maximum allowable spacing between restraints is as follows:

Piping, Conduit (EMT, IMC, RMC):	Not to exceed the tabulated spacings on pages 1m.1 and 1m.2.
No-Hub Cast Iron Pipe:	Not to exceed the tabulated spacings on page 1m.3 and 10 feet maximum.
Copper (Type K, L & M):	Not to exceed the tabulated spacings on pages 1m.2 and 1m.3.
Cable Tray:	Cable Tray restraint spacing shall be approved on a project specific basis, or preapproved by OSHPD. Spacing limits set by the manufacturer shall not be exceeded.
Duct:	Transverse: 30 feet on center (Per SMACNA Seismic Restraint Manual) Longitudinal: 60 feet on center (Per SMACNA Seismic Restraint Manual)

9. The last transverse restraint shall be located within 6 feet of the end of a system run (without change in direction). Also, the last longitudinal restraint shall be located within 20 feet of the end of a system run (without change in direction).

10. A transverse restraint may also provide longitudinal restraint at system changes in direction provided it is within 24 inches of the centerline of the system change in direction. Also, a longitudinal restraint may also provide transverse restraint at system changes in direction provided it is within 24 inches of the centerline of the system change in direction.

11. A system run shall consist of a straight section without a vertical or horizontal offset of more than 24 inches, and incidental change in direction exceeding $\pm 5^\circ$ vertically or horizontally. Each straight section shall have at least two transverse restraints and one longitudinal restraint.

12. Rigid bracing restraints are capable of resisting lateral forces in both tension and compression (e.g., strut) while flexible bracing restraints are only capable of resisting lateral forces in tension (e.g., cable). Also, flexible bracing restraints are beyond the OPM and require engineering design by RDP/SEOR.

13. Systems with significant "internal forces" (e.g., thermal change and thrust) are beyond the OPM and requires engineered design by RDP/SEOR.

14. Additional raceway system exceptions are provided in 2013 CBC 1616A.1.23 as noted below.

Modify ASCE 7, Section 13.6.5.6, Exceptions 1 and 2, as follows:

Exceptions:

1. Design for the seismic forces of Section 13.3 shall not be required for raceways where either:
 - a) Trapeze assemblies are used to support raceways and the total weight of the raceway supported by trapeze assemblies is less than 10 lb./ft. (146 N/m), or
 - b) The raceway is supported by hangers and each hanger in the raceway run is 12 in. (305 mm) or less in length from the raceway support point to the supporting structure. Where rod hangers are used with a diameter greater than $\frac{3}{8}$ inch, they shall be equipped with swivels to prevent inelastic bending in the rod (see swivel hangers on Page 6c.2 to satisfy this exception).
2. Design for the seismic forces of ASCE 7, Section 13.3 shall not be required for conduit, regardless of the value of I_p , where the conduit is up to 2.5 in. (64 mm) trade size.

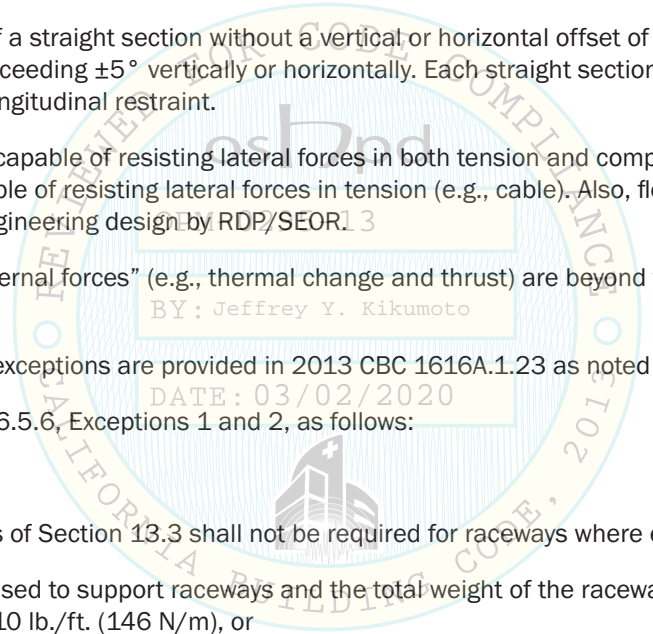

 <p style="text-align: center;">16100 S. Lathrop Ave Harvey, IL 60426 Toll-Free: (800) 882-5543</p> <p style="text-align: center;">www.unistrutseismic.com</p>	 Structural Engineer: Rami Elhassan California SE No. 3930	Page: <h1 style="text-align: center;">1i.3</h1>
	www.unistrutseismic.com	

System Notes

15. Additional ductwork system exceptions are provided in 2013 CBC 1616A.1.24 as noted below.

Replace ASCE 7, Section 13.6.7, Exceptions 1 and 2, with the following:

Exceptions:

The following exceptions pertain to ductwork not designed to carry toxic, highly toxic, or flammable gases or used for smoke control:

1. Design for the seismic forces of Section 13.3 shall not be required for ductwork where either:
 - a) Trapeze assemblies are used to support ductwork and the total weight of the ductwork supported by trapeze assemblies is less than 10 lb./ft. (146 N/m); or
 - b) The ductwork is supported by hangers and each hanger in the duct run is 12 in. (305 mm) or less in length from the duct support point to the supporting structure. Where rod hangers are used with a diameter greater than 3/8 inch, they shall be equipped with swivels to prevent inelastic bending in the rod (see swivel hangers on sheet 6c.2 to satisfy this exception).
2. Design for the seismic forces of ASCE 7, Section 13.3 shall not be required where provisions are made to avoid impact with larger ducts or mechanical components or to protect the ducts in the event of such impact; and HVAC ducts have a cross-sectional area of 6 ft² (0.557 m²) or less, or weigh 10 lb./ft. (146 N/m) or less.

16. Additional piping (mechanical and plumbing) system exceptions are provided in 2013 CBC 1616A.1.26 as noted below.

Replace ASCE 7, Section 13.6.8.3 with the following:

13.6.8.3 Exceptions. Design of piping systems and attachments for the seismic forces of Section 13.3 shall not be required where one of the following conditions apply:

1. Trapeze assemblies are used to support piping whereby no single pipe exceeds the limits set forth in 3a or 3b below and the total weight of the piping supported by the trapeze assemblies is less than 10 lb./ft. (146 N/m).
2. The piping is supported by hangers and each hanger in the piping run is 12 in. (305 mm) or less in length from the top of the pipe to the supporting structure. Where pipes are supported on a trapeze, the trapeze shall be supported by hangers having a length of 12 in. (305 mm) or less. Where rod hangers are used with a diameter greater than 3/8 inch, they shall be equipped with swivels, eye nuts or other devices to prevent bending in the rod (see swivel hangers on sheet 6c.2 to satisfy this exception).
3. Piping having an R_p in ASCE 7, Table 13.6-1 of 4.5 or greater is used and provisions are made to avoid impact with other structural or nonstructural components or to protect the piping in the event of such impact and where the following size requirements are satisfied:
 - a) For Seismic Design Categories D, E or F and values of I_p greater than one, the nominal pipe size shall be 1 inch (25 mm) or less.
 - b) For Seismic Design Categories D, E or F, where $I_p = 1.0$, the nominal pipe size shall be 3 inches (80mm) or less.

[User note: cast iron, plastic, and other nonductile piping have an R_p less than 4.5 and do not qualify.]

17. Conditions not specifically addressed within this OPM require the assistance of RDP/SEOR.

Atkore
Unistrut

16100 S. Lathrop Ave
Harvey, IL 60426
Toll-Free: (800) 882-5543

www.unistrutseismic.com



Structural Engineer: Rami Elhassan
California SE No. 3930

Page:

1i.4

System Notes

RELATED EXCERPT FROM ASCE 7-10

TABLE 13.6-1 Seismic Coefficients for Mechanical and Electrical Components

MECHANICAL AND ELECTRICAL COMPONENTS	a_p^a	R_p^b	Ω_0^c
VIBRATION ISOLATED COMPONENTS AND SYSTEMS^b			
Internally isolated components and systems.	2 ^{1/2}	2	2
Suspended vibration isolated equipment including in-line duct devices and suspended internally internally isolated components.	2 ^{1/2}	2 ^{1/2}	2
DISTRIBUTION SYSTEMS			
Piping in accordance with ASME B31, including in-line components with joints made by welding or brazing	2 ^{1/2}	12*	2
Piping in accordance with ASME B31, including in-line components, constructed of high or limited deformability materials, with joints made by threading, bonding, compression couplings or grooved couplings.	2 ^{1/2}	6	2
Piping and tubing not in accordance with ASME B31, including in-line components, constructed of high-deformability materials, with joints made by welding or brazing.	2 ^{1/2}	9*	2
Piping and tubing not in accordance with ASME B31, including in-line components, constructed of high- or limited-deformability materials, with joints made by threading, bonding, compression couplings or grooved couplings.	2 ^{1/2}	4 ^{1/2}	2
Piping and tubing constructed of low-deformability materials, such as cast iron, glass, and nonductile plastics.	2 ^{1/2}	3	2
Ductwork, including in-line components, constructed of high-deformability materials, with joints made by welding or brazing.	2 ^{1/2}	9*	2
Ductwork, including in-line components, constructed of high- or limited-deformability materials, with joints made by means other than welding or brazing.	2 ^{1/2}	6	2
Ductwork, including in-line components, constructed of low-deformability materials, such as cast iron, glass or nonductile plastics.	2 ^{1/2}	3	2
Electrical conduit and cable trays	2 ^{1/2}	6	2
Bus ducts	1	2 ^{1/2}	2
Plumbing	1	2 ^{1/2}	2
Manufacturing or process conveyors (nonpersonnel).	2 ^{1/2}	3	2

^a A lower value for a_p is permitted where justified by detailed dynamic analyses. The value for a_p shall not be less than 1. The value of a_p equal to 1 is for rigid components and rigidly attached components. The value of a_p equal to 2^{1/2} is for flexible components and flexibly attached components.

^b Components mounted on vibration isolators shall have a bumper restraint or snubber in each horizontal direction. The design force shall be taken as $2F_p$ if the nominal clearance (air gap) between the equipment support frame and restraint is greater than 0.25 in. If the nominal clearance specified on the construction documents is not greater than 0.25 in., the design force is permitted to be taken as F_p .

^c Overstrength as required for anchorage to concrete. See Section 12.4.3 for inclusion of overstrength factor in seismic load effect.

* Per ASCE 7-10 §13.4.1 do not use an R_p factor greater than 6.0 when calculating the F_p & E_v for design of the attachment.



16100 S. Lathrop Ave
Harvey, IL 60426
Toll-Free: (800) 882-5543

www.unistrutseismic.com

Structural Engineer: Rami Elhassan
California SE No. 3930

Page:

1i.5

Material Notes

1. Structural Steel:

- a. Steel materials shall conform to the following, unless noted otherwise (U.N.O.):
 - Plates and bars: ASTM A36 (Fy=36ksi, Fu=58ksi)
 - Bolts: ASTM A307 or SAE J429 Grade 2
 - Nuts: ASTM A563
 - Washers: ASTM F436 or ASTM F844
 - Stainless Steel: ASTM A240 Type 304 or Better (Fy=30ksi, Fu=75ksi)
 - Strut Channel: ASTM A653 SS Grade 33 at 12ga. thickness
 - Telespar: ASTM A653 SS Grade 50, Class 2 min at 12ga. thickness
 - Channel & Telespar Fittings: ASTM A1011 SS Grade 33 min at 1/4" or thicker, or
ASTM A1011 HSLAS Grade 45 min at 0.220" or thicker
 - Threaded Rod: Fy = 36 ksi min
- b. All steel (except stainless steel) shall be shop primed with zinc oxide primer unless noted otherwise.
- c. Paint all structural steel with weather/rust resistant paint in accordance with the project specifications and architectural details unless noted otherwise.
- d. Diameter of bolt holes shall be $\frac{1}{16}$ " larger than the bolt's diameter.
- e. Fender washers to be in accordance with ASME B18.21.1-2009, Type B, Wide Series.
- f. All exposed steel finish shall be determined by the owner/end user. If unknown, provide stainless steel.

2. Steel studs, joists and accessories:

- a. Steel studs, joists and accessories shall comply with requirements of the AISI Cold-Formed Steel Design Manual, 2008 Edition.
- b. Steel studs, joists and accessories shall be formed from steel with a minimum yield stress of 50ksi for 16 gauge and heavier items, or 33ksi for 18 gage and lighter items.
- c. Steel studs, joists and accessories shall be galvanized in accordance with ASTM A653, GR60, unless noted otherwise.
- d. Sheet metal screws (SMS) shall comply with the requirements of the AISI Cold-Formed Steel Design Manual, 2008 Edition and may be self-drilling and/or self-tapping as desired.
- e. Penetrations of screws through jointed materials shall not be less than 3 exposed threads. Screws shall be installed and tightened in accordance with screw manufacturer's recommendations

3. Wood:

- a. Wood members shall be Douglas Fir-Larch per WCLIB visually graded dimension lumber and shall be surfaced dry (19% moisture content maximum), structural framing members shall be S4S and grade marked as No. 2 minimum.
- b. Nails shall be common wire nails (0.131" dia. x 2 1/2" for 8d; 0.148" dia. x 3" for 10d; 0.148" dia. x 3 1/4" for 12d; 0.162" dia. x 3 1/2" for 16d) or fasteners provided with hardware connectors specified in OPM.
- c. Wood Screws shall be screwed, not driven, into wood member. Wood screw shall be Simpson Strong-Tie SDS screw 1/4" dia. x 3 1/2" min (ICC-ES ESR-2236) with 2 1/4" min penetration into wood member.
- d. Wood screw finish shall be determined by the owner/end user. If unknown, provide stainless steel.

Atkore
Unistrut

16100 S. Lathrop Ave
Harvey, IL 60426
Toll-Free: (800) 882-5543

www.unistrutseismic.com

Structural Engineer: Rami Elhassan
California SE No. 3930

Page:

1j.1

Layout of Seismic Bracing Requirements

Layout for Piping, Conduit, Tube and Ductwork



OVERVIEW

I. There are three types of braces to restrain horizontal seismic loads.

Type 1: Transverse Brace - Braces against loads perpendicular to its run

Type 2: Longitudinal Brace - Braces against loads parallel to its run

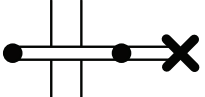
Type 3: All-Directional (Transverse & Longitudinal) Brace

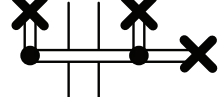
Legend - Brace Details			
l_T = Maximum Transverse Brace Spacing	Transverse Brace 	Longitudinal Brace 	Transverse & Longitudinal Brace 
l_L = Maximum Longitudinal Brace Spacing			

II. Offsets of less than 24" can be treated as a single run.

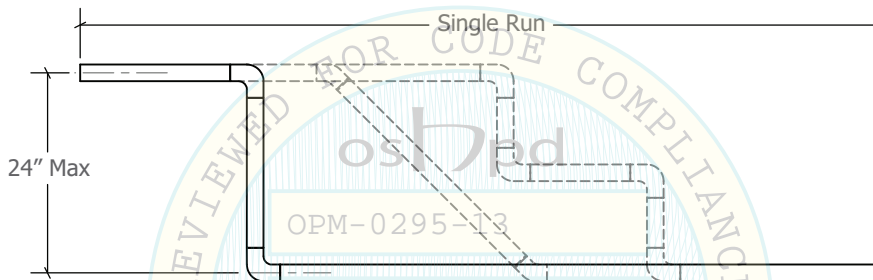

III. Transverse braces located within 24" of an elbow or tee can serve as both a transverse brace for the attached run and a longitudinal brace for the adjacent run. For ductwork, consider the width of the duct to ensure that there is not a clash between the brace and duct. If a clash is present, move the brace and that brace may not be useable as a longitudinal brace as noted here if the 24" max criteria is exceeded.

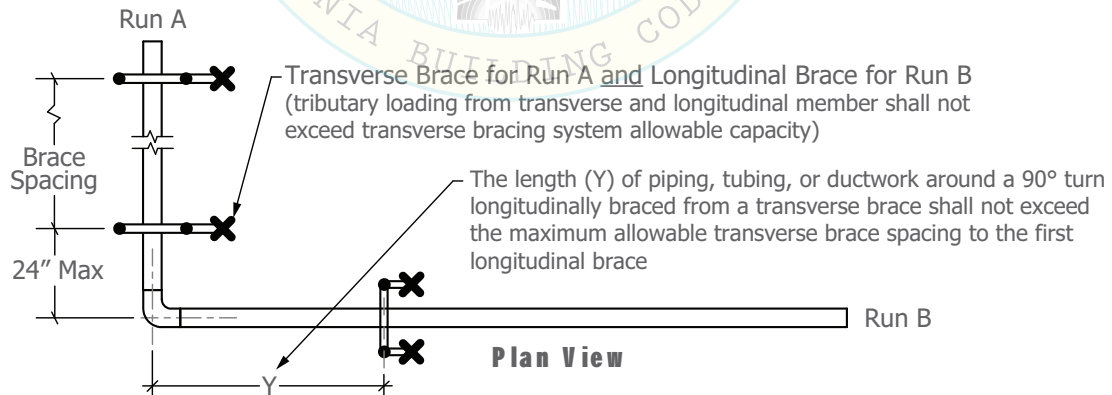

Atkore
Unistrut

16100 S. Lathrop Ave
Harvey, IL 60426
Toll-Free: (800) 882-5543

www.unistrutseismic.com



Structural Engineer: Rami Elhassan
California SE No. 3930

Page:

1k.1

Layout of Seismic Bracing Requirements

Layout for Piping, Conduit, Tube and Ductwork

Placing Transverse Braces*:

For each run, place transverse braces within 24" of an elbow or tee, and so that individual spans do not exceed the transverse brace spacing (I_T) as determined in sections 1, 2 and 8.

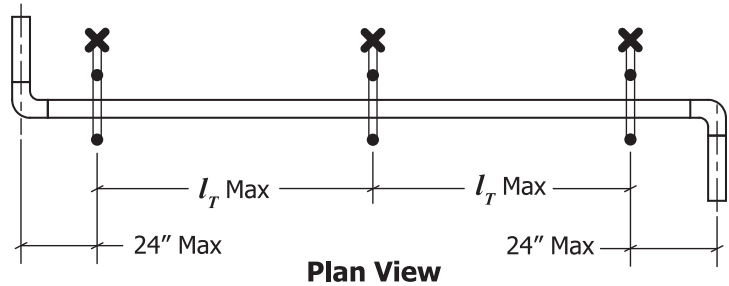

Placing Longitudinal Braces*:

Place longitudinal braces so that individual spans do not exceed the longitudinal brace spacing (I_L) as determined in sections 1, 2 and 8.

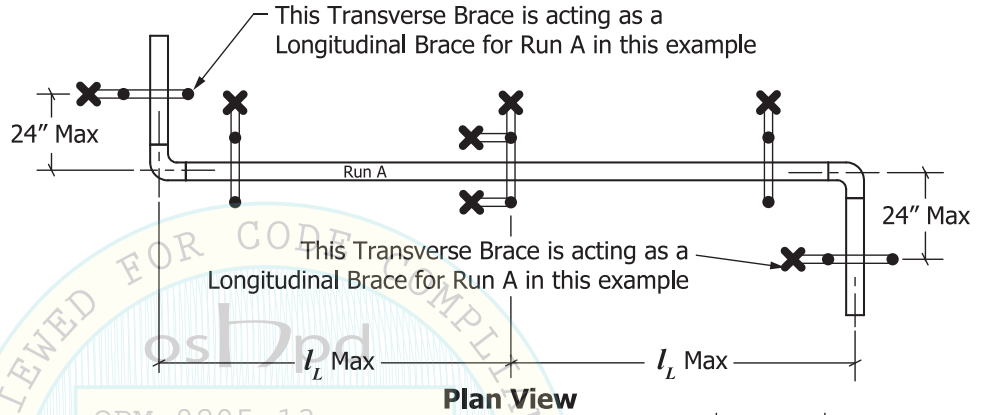

See note III on previous page for using certain braces as both a transverse and longitudinal restraints

Requirement:

Each straight run requires a minimum of (2) transverse braces and (1) longitudinal brace.

Bracing Vertical Drops:

Place a transverse brace within 24" of the vertical drop.

A floor brace is required (as shown) if the noted conditions are met.

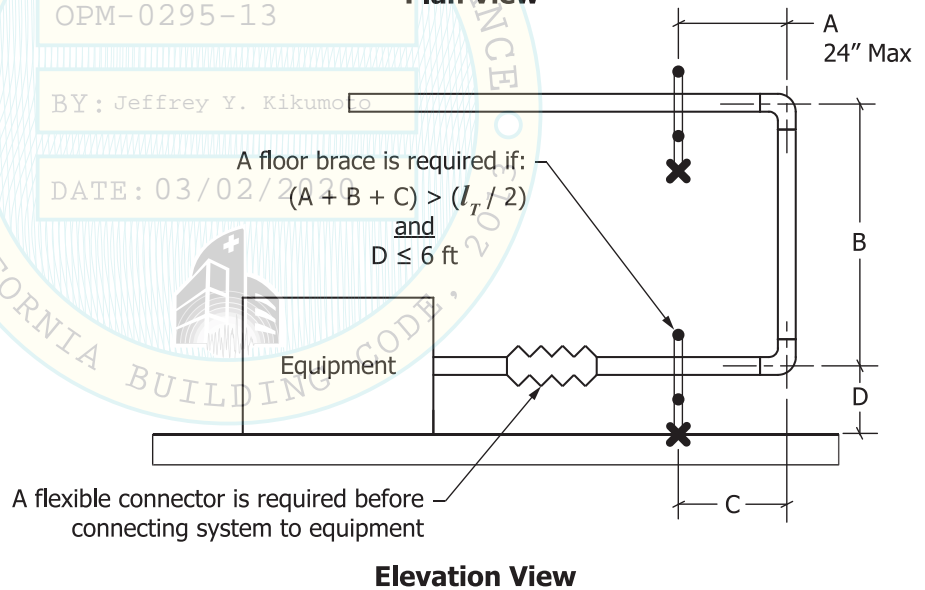

***Ductwork:** Braces that project to the overhead structure shall be installed between 30° and 60° from horizontal. Where an adjacent wall occurs, braces that project to that wall shall be installed directly horizontal (0°) or as indicated above. Capacity limitations of the brace may occur as well as the method of connection to the structure. Consider the width of the duct to ensure that there is not a clash between the brace and duct.

Atkore™
Unistrut

16100 S. Lathrop Ave
Harvey, IL 60426
Toll-Free: (800) 882-5543

www.unistrutseismic.com

Rami Elhassan

Structural Engineer: Rami Elhassan
California SE No. 3930

Page:

1k.2

F_p / W_p Tables

Governing F _p / W _p Table (ASD) Where S _{DS} = 0.8g and I _p = 1.5 [E _v (ASD) = 0.7 x 0.2 x 0.8 x W _p = 0.112W _p]											
z / h a _p / R _p	0%	10%	20%	30%	40%	50%	60%	70%	80%	90%	100%
2.5 / 12	0.25	0.25	0.25	0.25	0.25	0.25	0.25	0.25	0.25	0.25	0.25
2.5 / 9	0.25	0.25	0.25	0.25	0.25	0.25	0.25	0.25	0.25	0.26	0.28
1 / 2.5	0.25	0.25	0.25	0.25	0.25	0.27	0.30	0.32	0.35	0.38	0.40
2.5 / 6	0.25	0.25	0.25	0.25	0.25	0.28	0.31	0.34	0.36	0.39	0.42
2.5 / 4.5	0.25	0.25	0.26	0.30	0.34	0.37	0.41	0.45	0.49	0.52	0.56
1 / 1.5	0.25	0.27	0.31	0.36	0.40	0.45	0.49	0.54	0.58	0.63	0.67
2.5 / 3	0.28	0.34	0.39	0.45	0.50	0.56	0.62	0.67	0.73	0.78	0.84
2.5 / 2.5	0.34	0.40	0.47	0.54	0.60	0.67	0.74	0.81	0.87	0.94	1.01
2.5 / 2	0.42	0.50	0.59	0.67	0.76	0.84	0.92	1.01	1.09	1.18	1.26

Governing F _p / W _p Table (ASD) Where S _{DS} = 0.9g and I _p = 1.5 [E _v (ASD) = 0.7 x 0.2 x 0.9 x W _p = 0.126W _p]											
z / h a _p / R _p	0%	10%	20%	30%	40%	50%	60%	70%	80%	90%	100%
2.5 / 12	0.28	0.28	0.28	0.28	0.28	0.28	0.28	0.28	0.28	0.28	0.28
2.5 / 9	0.28	0.28	0.28	0.28	0.28	0.28	0.28	0.28	0.28	0.29	0.32
1 / 2.5	0.28	0.28	0.28	0.28	0.28	0.30	0.33	0.36	0.39	0.42	0.45
2.5 / 6	0.28	0.28	0.28	0.28	0.28	0.32	0.35	0.38	0.41	0.44	0.47
2.5 / 4.5	0.28	0.28	0.29	0.34	0.38	0.42	0.46	0.50	0.55	0.59	0.63
1 / 1.5	0.28	0.30	0.35	0.40	0.45	0.50	0.55	0.60	0.66	0.71	0.76
2.5 / 3	0.32	0.38	0.44	0.50	0.57	0.63	0.69	0.76	0.82	0.88	0.95
2.5 / 2.5	0.38	0.45	0.53	0.60	0.68	0.76	0.83	0.91	0.98	1.06	1.13
2.5 / 2	0.47	0.57	0.66	0.76	0.85	0.95	1.04	1.13	1.23	1.32	1.42

Governing F _p / W _p Table (ASD) Where S _{DS} = 1.0g and I _p = 1.5 [E _v (ASD) = 0.7 x 0.2 x 1.0 x W _p = 0.140W _p]											
z / h a _p / R _p	0%	10%	20%	30%	40%	50%	60%	70%	80%	90%	100%
2.5 / 12	0.32	0.32	0.32	0.32	0.32	0.32	0.32	0.32	0.32	0.32	0.32
2.5 / 9	0.32	0.32	0.32	0.32	0.32	0.32	0.32	0.32	0.32	0.33	0.35
1 / 2.5	0.32	0.32	0.32	0.32	0.32	0.34	0.37	0.40	0.44	0.47	0.50
2.5 / 6	0.32	0.32	0.32	0.32	0.32	0.35	0.39	0.42	0.46	0.49	0.53
2.5 / 4.5	0.32	0.32	0.33	0.37	0.42	0.47	0.51	0.56	0.61	0.65	0.70
1 / 1.5	0.32	0.34	0.39	0.45	0.50	0.56	0.62	0.67	0.73	0.78	0.84
2.5 / 3	0.35	0.42	0.49	0.56	0.63	0.70	0.77	0.84	0.91	0.98	1.05
2.5 / 2.5	0.42	0.50	0.59	0.67	0.76	0.84	0.92	1.01	1.09	1.18	1.26
2.5 / 2	0.53	0.63	0.74	0.84	0.95	1.05	1.16	1.26	1.37	1.47	1.58

Notes:

- 1) Yellow shaded section of Table indicates Code Minimum F_p / W_p governs.
- 2) Unshaded section of Table is the calculated F_p / W_p value.
- 3) Gray shaded section of Table indicates F_p / W_p forces beyond the limit permitted by Page 2a.1. Design shall be by the RDP or SEOR per the remaining sections within this OPM (Pre-design tables are not permitted).
- 4) The design force in the attachment cannot have R_p > 6 per ASCE 7-10 §13.4.1. Reference OPM page 1i.2.

 <p>16100 S. Lathrop Ave Harvey, IL 60426 Toll-Free: (800) 882-5543</p> <p style="text-align: center;">www.unistrutseismic.com</p>	 Structural Engineer: Rami Elhassan California SE No. 3930	Page: <h1 style="margin: 0;">11.1</h1>
	DATE: 03/02/2020	

F_p / W_p Tables

Governing F _p / W _p Table (ASD) Where S _{DS} = 1.1g and I _p = 1.5 [E _v (ASD) = 0.7 x 0.2 x 1.1 x W _p = 0.154W _p]											
z / h a _p / R _p	0%	10%	20%	30%	40%	50%	60%	70%	80%	90%	100%
2.5 / 12	0.35	0.35	0.35	0.35	0.35	0.35	0.35	0.35	0.35	0.35	0.35
2.5 / 9	0.35	0.35	0.35	0.35	0.35	0.35	0.35	0.35	0.35	0.36	0.39
1 / 2.5	0.35	0.35	0.35	0.35	0.35	0.37	0.41	0.44	0.48	0.52	0.55
2.5 / 6	0.35	0.35	0.35	0.35	0.35	0.39	0.42	0.46	0.50	0.54	0.58
2.5 / 4.5	0.35	0.35	0.36	0.41	0.46	0.51	0.56	0.62	0.67	0.72	0.77
1 / 1.5	0.35	0.37	0.43	0.49	0.55	0.62	0.68	0.74	0.80	0.86	0.92
2.5 / 3	0.39	0.46	0.54	0.62	0.69	0.77	0.85	0.92	1.00	1.08	1.16
2.5 / 2.5	0.46	0.55	0.65	0.74	0.83	0.92	1.02	1.11	1.20	1.29	1.39
2.5 / 2	0.58	0.69	0.81	0.92	1.04	1.16	1.27	1.39	1.50	1.62	1.73

Governing F _p / W _p Table (ASD) Where S _{DS} = 1.2g and I _p = 1.5 [E _v (ASD) = 0.7 x 0.2 x 1.2 x W _p = 0.168W _p]											
z / h a _p / R _p	0%	10%	20%	30%	40%	50%	60%	70%	80%	90%	100%
2.5 / 12	0.38	0.38	0.38	0.38	0.38	0.38	0.38	0.38	0.38	0.38	0.38
2.5 / 9	0.38	0.38	0.38	0.38	0.38	0.38	0.38	0.38	0.38	0.39	0.42
1 / 2.5	0.38	0.38	0.38	0.38	0.38	0.40	0.44	0.48	0.52	0.56	0.60
2.5 / 6	0.38	0.38	0.38	0.38	0.38	0.42	0.46	0.50	0.55	0.59	0.63
2.5 / 4.5	0.38	0.38	0.39	0.45	0.50	0.56	0.62	0.67	0.73	0.78	0.84
1 / 1.5	0.38	0.40	0.47	0.54	0.60	0.67	0.74	0.81	0.87	0.94	1.01
2.5 / 3	0.42	0.50	0.59	0.67	0.76	0.84	0.92	1.01	1.09	1.18	1.26
2.5 / 2.5	0.50	0.60	0.71	0.81	0.91	1.01	1.11	1.21	1.31	1.41	1.51
2.5 / 2	0.63	0.76	0.88	1.01	1.13	1.26	1.39	1.51	1.64	1.76	1.89

Governing F _p / W _p Table (ASD) Where S _{DS} = 1.3g and I _p = 1.5 [E _v (ASD) = 0.7 x 0.2 x 1.3 x W _p = 0.182W _p]											
z / h a _p / R _p	0%	10%	20%	30%	40%	50%	60%	70%	80%	90%	100%
2.5 / 12	0.41	0.41	0.41	0.41	0.41	0.41	0.41	0.41	0.41	0.41	0.41
2.5 / 9	0.41	0.41	0.41	0.41	0.41	0.41	0.41	0.41	0.41	0.42	0.46
1 / 2.5	0.41	0.41	0.41	0.41	0.41	0.44	0.48	0.52	0.57	0.61	0.66
2.5 / 6	0.41	0.41	0.41	0.41	0.41	0.46	0.50	0.55	0.59	0.64	0.68
2.5 / 4.5	0.41	0.41	0.42	0.49	0.55	0.61	0.67	0.73	0.79	0.85	0.91
1 / 1.5	0.41	0.44	0.51	0.58	0.66	0.73	0.80	0.87	0.95	1.02	1.09
2.5 / 3	0.46	0.55	0.64	0.73	0.82	0.91	1.00	1.09	1.18	1.27	1.37
2.5 / 2.5	0.55	0.66	0.76	0.87	0.98	1.09	1.20	1.31	1.42	1.53	1.64
2.5 / 2	0.68	0.82	0.96	1.09	1.23	1.37	1.50	1.64	1.77	1.91	2.05

Notes:

- 1) Yellow shaded section of Table indicates Code Minimum F_p / W_p governs.
- 2) Unshaded section of Table is the calculated F_p / W_p value.
- 3) Gray shaded section of Table indicates F_p / W_p forces beyond the limit permitted by Page 2a.1. Design shall be by the RDP or SEOR per the remaining sections within this OPM (Pre-design tables are not permitted).
- 4) The design force in the attachment cannot have R_p > 6 per ASCE 7-10 §13.4.1. Reference OPM page 1i.2.



16100 S. Lathrop Ave
Harvey, IL 60426
Toll-Free: (800) 882-5543

www.unistrutseismic.com

Structural Engineer: Rami Elhassan
California SE No. 3930

Page:

11.2

F_p / W_p Tables

Governing F _p / W _p Table (ASD) Where S _{DS} = 1.4g and I _p = 1.5 [E _v (ASD) = 0.7 x 0.2 x 1.4 x W _p = 0.196W _p]											
z / h a _p / R _p	0%	10%	20%	30%	40%	50%	60%	70%	80%	90%	100%
2.5 / 12	0.44	0.44	0.44	0.44	0.44	0.44	0.44	0.44	0.44	0.44	0.44
2.5 / 9	0.44	0.44	0.44	0.44	0.44	0.44	0.44	0.44	0.44	0.46	0.49
1 / 2.5	0.44	0.44	0.44	0.44	0.44	0.47	0.52	0.56	0.61	0.66	0.71
2.5 / 6	0.44	0.44	0.44	0.44	0.44	0.49	0.54	0.59	0.64	0.69	0.74
2.5 / 4.5	0.44	0.44	0.46	0.52	0.59	0.65	0.72	0.78	0.85	0.91	0.98
1 / 1.5	0.44	0.47	0.55	0.63	0.71	0.78	0.86	0.94	1.02	1.10	1.18
2.5 / 3	0.49	0.59	0.69	0.78	0.88	0.98	1.08	1.18	1.27	1.37	1.47
2.5 / 2.5	0.59	0.71	0.82	0.94	1.06	1.18	1.29	1.41	1.53	1.65	1.76
2.5 / 2	0.74	0.88	1.03	1.18	1.32	1.47	1.62	1.76	1.91	2.06	2.21

Governing F _p / W _p Table (ASD) Where S _{DS} = 1.5g and I _p = 1.5 [E _v (ASD) = 0.7 x 0.2 x 1.5 x W _p = 0.210W _p]											
z / h a _p / R _p	0%	10%	20%	30%	40%	50%	60%	70%	80%	90%	100%
2.5 / 12	0.47	0.47	0.47	0.47	0.47	0.47	0.47	0.47	0.47	0.47	0.47
2.5 / 9	0.47	0.47	0.47	0.47	0.47	0.47	0.47	0.47	0.47	0.49	0.53
1 / 2.5	0.47	0.47	0.47	0.47	0.47	0.50	0.55	0.60	0.66	0.71	0.76
2.5 / 6	0.47	0.47	0.47	0.47	0.47	0.53	0.58	0.63	0.68	0.74	0.79
2.5 / 4.5	0.47	0.47	0.49	0.56	0.63	0.70	0.77	0.84	0.91	0.98	1.05
1 / 1.5	0.47	0.50	0.59	0.67	0.76	0.84	0.92	1.01	1.09	1.18	1.26
2.5 / 3	0.53	0.63	0.74	0.84	0.95	1.05	1.16	1.26	1.37	1.47	1.58
2.5 / 2.5	0.63	0.76	0.88	1.01	1.13	1.26	1.39	1.51	1.64	1.76	1.89
2.5 / 2	0.79	0.95	1.10	1.26	1.42	1.58	1.73	1.89	2.05	2.21	2.36

Governing F _p / W _p Table (ASD) Where S _{DS} = 1.6g and I _p = 1.5 [E _v (ASD) = 0.7 x 0.2 x 1.6 x W _p = 0.224W _p]											
z / h a _p / R _p	0%	10%	20%	30%	40%	50%	60%	70%	80%	90%	100%
2.5 / 12	0.50	0.50	0.50	0.50	0.50	0.50	0.50	0.50	0.50	0.50	0.50
2.5 / 9	0.50	0.50	0.50	0.50	0.50	0.50	0.50	0.50	0.50	0.52	0.56
1 / 2.5	0.50	0.50	0.50	0.50	0.50	0.54	0.59	0.65	0.70	0.75	0.81
2.5 / 6	0.50	0.50	0.50	0.50	0.50	0.56	0.62	0.67	0.73	0.78	0.84
2.5 / 4.5	0.50	0.50	0.52	0.60	0.67	0.75	0.82	0.90	0.97	1.05	1.12
1 / 1.5	0.50	0.54	0.63	0.72	0.81	0.90	0.99	1.08	1.16	1.25	1.34
2.5 / 3	0.56	0.67	0.78	0.90	1.01	1.12	1.23	1.34	1.46	1.57	1.68
2.5 / 2.5	0.67	0.81	0.94	1.08	1.21	1.34	1.48	1.61	1.75	1.88	2.02
2.5 / 2	0.84	1.01	1.18	1.34	1.51	1.68	1.85	2.02	2.18	2.35	2.52

Notes:

- 1) Yellow shaded section of Table indicates Code Minimum F_p / W_p governs.
- 2) Unshaded section of Table is the calculated F_p / W_p value.
- 3) Gray shaded section of Table indicates F_p / W_p forces beyond the limit permitted by Page 2a.1. Design shall be by the RDP or SEOR per the remaining sections within this OPM (Pre-design tables are not permitted).
- 4) The design force in the attachment cannot have R_p > 6 per ASCE 7-10 §13.4.1. Reference OPM page 1i.2.



16100 S. Lathrop Ave
Harvey, IL 60426
Toll-Free: (800) 882-5543

www.unistrutseismic.com

Structural Engineer: Rami Elhassan
California SE No. 3930

Page:

11.3

F_p / W_p Tables

Governing F _p / W _p Table (ASD) Where S _{DS} = 1.7g and I _p = 1.5 [E _v (ASD) = 0.7 x 0.2 x 1.7 x W _p = 0.238W _p]											
z / h a _p / R _p	0%	10%	20%	30%	40%	50%	60%	70%	80%	90%	100%
2.5 / 12	0.54	0.54	0.54	0.54	0.54	0.54	0.54	0.54	0.54	0.54	0.54
2.5 / 9	0.54	0.54	0.54	0.54	0.54	0.54	0.54	0.54	0.54	0.56	0.60
1 / 2.5	0.54	0.54	0.54	0.54	0.54	0.57	0.63	0.69	0.74	0.80	0.86
2.5 / 6	0.54	0.54	0.54	0.54	0.54	0.60	0.65	0.71	0.77	0.83	0.89
2.5 / 4.5	0.54	0.54	0.56	0.63	0.71	0.79	0.87	0.95	1.03	1.11	1.19
1 / 1.5	0.54	0.57	0.67	0.76	0.86	0.95	1.05	1.14	1.24	1.33	1.43
2.5 / 3	0.60	0.71	0.83	0.95	1.07	1.19	1.31	1.43	1.55	1.67	1.79
2.5 / 2.5	0.71	0.86	1.00	1.14	1.29	1.43	1.57	1.71	1.86	2.00	2.14
2.5 / 2	0.89	1.07	1.25	1.43	1.61	1.79	1.96	2.14	2.32	2.50	2.68

Governing F _p / W _p Table (ASD) Where S _{DS} = 1.8g and I _p = 1.5 [E _v (ASD) = 0.7 x 0.2 x 1.8 x W _p = 0.252W _p]											
z / h a _p / R _p	0%	10%	20%	30%	40%	50%	60%	70%	80%	90%	100%
2.5 / 12	0.57	0.57	0.57	0.57	0.57	0.57	0.57	0.57	0.57	0.57	0.57
2.5 / 9	0.57	0.57	0.57	0.57	0.57	0.57	0.57	0.57	0.57	0.59	0.63
1 / 2.5	0.57	0.57	0.57	0.57	0.57	0.60	0.67	0.73	0.79	0.85	0.91
2.5 / 6	0.57	0.57	0.57	0.57	0.57	0.63	0.69	0.76	0.82	0.88	0.95
2.5 / 4.5	0.57	0.57	0.59	0.67	0.76	0.84	0.92	1.01	1.09	1.18	1.26
1 / 1.5	0.57	0.60	0.71	0.81	0.91	1.01	1.11	1.21	1.31	1.41	1.51
2.5 / 3	0.63	0.76	0.88	1.01	1.13	1.26	1.39	1.51	1.64	1.76	1.89
2.5 / 2.5	0.76	0.91	1.06	1.21	1.36	1.51	1.66	1.81	1.97	2.12	2.27
2.5 / 2	0.95	1.13	1.32	1.51	1.70	1.89	2.08	2.27	2.46	2.65	2.84

Governing F _p / W _p Table (ASD) Where S _{DS} = 1.9g and I _p = 1.5 [E _v (ASD) = 0.7 x 0.2 x 1.9 x W _p = 0.266W _p]											
z / h a _p / R _p	0%	10%	20%	30%	40%	50%	60%	70%	80%	90%	100%
2.5 / 12	0.60	0.60	0.60	0.60	0.60	0.60	0.60	0.60	0.60	0.60	0.60
2.5 / 9	0.60	0.60	0.60	0.60	0.60	0.60	0.60	0.60	0.60	0.62	0.67
1 / 2.5	0.60	0.60	0.60	0.60	0.60	0.64	0.70	0.77	0.83	0.89	0.96
2.5 / 6	0.60	0.60	0.60	0.60	0.60	0.67	0.73	0.80	0.86	0.93	1.00
2.5 / 4.5	0.60	0.60	0.62	0.71	0.80	0.89	0.98	1.06	1.15	1.24	1.33
1 / 1.5	0.60	0.64	0.74	0.85	0.96	1.06	1.17	1.28	1.38	1.49	1.60
2.5 / 3	0.67	0.80	0.93	1.06	1.20	1.33	1.46	1.60	1.73	1.86	2.00
2.5 / 2.5	0.80	0.96	1.12	1.28	1.44	1.60	1.76	1.92	2.07	2.23	2.39
2.5 / 2	1.00	1.20	1.40	1.60	1.80	2.00	2.19	2.39	2.59	2.79	2.99

Notes:

- 1) Yellow shaded with gray hatching section of Table indicates Code Minimum F_p / W_p governs and that note 2 (below) applies.
- 2) Gray shaded section of Table indicates F_p / W_p forces beyond the limit permitted by Page 2a.1. Design shall be by the RDP or SEOR per the remaining sections within this OPM (Pre-design tables are not permitted).
- 3) The use of pre-design tables is not permitted where S_{DS} > 1.786g.
- 4) The design force in the attachment cannot have R_p > 6 per ASCE 7-10 §13.4.1. Reference OPM page 1i.2.



16100 S. Lathrop Ave
Harvey, IL 60426
Toll-Free: (800) 882-5543

www.unistrutseismic.com

Structural Engineer: Rami Elhassan
California SE No. 3930

Page:

11.4

Max Transverse (I_T) & Longitudinal (I_L) Brace Spacing

SCH. 10 STEEL PIPE

$(E_V = 0.3 W_p)$

Maximum Brace Spacing (ft.) [I_T or I_L^2]								
Nom. Dia. (in.)	F_p/W_p (ASD)	Max Vertical Support Spacing	0.5 or less	1	1.5	2	2.5	3
1	10	10	21	18	16	15	14	14
1¼	10	10	24	20	18	17	16	15
1½	10	10	25	21	19	18	17	16
2	10	10	28	23	21	19	18	18
2½	10	10	30	25	23	21	20	19
3	10	10	32	27	25	23	22	21
3½	10	10	34	29	26	24	23	22
4	10	10	36	30	27	25	24	23
5	10	10	39	33	30	28	26	25
6	10	10	40	35	32	30	28	27
8	10	10	40	38	35	32	30	29

- 1) Includes pipe, water and fittings allowance (see appendix).
- 2) For longitudinal (I_L) & all-directional brace spacing, multiply the tabulated values by 3. Brace and/or connector capacity may govern max spacings in some cases.
- 3) Piping in accordance with ASME B31, including in-line components, constructed of high or limited deformability materials, with joints made by threading, bonding, compression couplings, or grooved couplings.
- 4) Brace spacing based on steel pipe conforming to ASTM A53 Type E, Grade A with $F_y = 30$ ksi min.
- 5) Rigid grooved couplings listed for UL standard UL 213 may use max brace spacings.
- 6) Max gravity support spacing based on 2013 California Plumbing Code Table 313.3.

SCH. 40 STEEL PIPE

$(E_V = 0.3 W_p)$

Maximum Brace Spacing (ft.) [I_T or I_L^2]								
Nom. Dia. (in.)	F_p/W_p (ASD)	Max Vertical Support Spacing	0.5 or less	1	1.5	2	2.5	3
1	10	10	19	16	15	14	13	12
1¼	10	10	22	19	17	16	15	14
1½	10	10	24	20	18	17	16	15
2	10	10	26	22	20	19	18	17
2½	10	10	30	25	23	21	20	19
3	10	10	33	28	25	23	22	21
3½	10	10	35	29	26	25	23	22
4	10	10	37	31	28	26	25	23
5	10	10	40	34	31	28	27	26
6	10	10	40	37	33	31	29	28
8	10	10	40	40	38	35	33	32

- 1) Includes pipe, water and insulation (see appendix).
- 2) For longitudinal (I_L) & all-directional brace spacing, multiply the tabulated values by 3. Brace and/or connector capacity may govern max spacings in some cases.
- 3) Piping in accordance with ASME B31, including in-line components, constructed of high or limited deformability materials, with joints made by threading, bonding, compression couplings, or grooved couplings.
- 4) Brace spacing based on steel pipe conforming to ASTM A53 Type E, Grade B with $F_y = 35$ ksi min.
- 5) Rigid grooved couplings listed for UL standard UL 213 may use max brace spacings.
- 6) Max gravity support spacing based on 2013 California Plumbing Code Table 313.3.

SCH. 80 STEEL PIPE

$(E_V = 0.3 W_p)$

Maximum Brace Spacing (ft.) [I_T or I_L^2]								
Nom. Dia. (in.)	F_p/W_p (ASD)	Max Vertical Support Spacing	0.5 or less	1	1.5	2	2.5	3
1	10	10	20	17	15	14	13	13
1¼	10	10	23	19	17	16	15	15
1½	10	10	24	20	19	17	16	16
2	10	10	27	23	21	19	18	18
2½	10	10	31	26	23	22	20	19
3	10	10	34	28	26	24	23	22
3½	10	10	36	30	27	26	24	23
4	10	10	38	32	29	27	26	24
5	10	10	40	35	32	30	28	27
6	10	10	40	39	35	33	31	30
8	10	10	40	40	40	37	35	34

- 1) Includes pipe, water and insulation (see appendix).
- 2) For longitudinal (I_L) & all-directional brace spacing, multiply the tabulated values by 3. Brace and/or connector capacity may govern max spacings in some cases.
- 3) Piping in accordance with ASME B31, including in-line components, constructed of high or limited deformability materials, with joints made by threading, bonding, compression couplings, or grooved couplings.
- 4) Brace spacing based on steel pipe conforming to ASTM A53 Type E, Grade A with $F_y = 30$ ksi min.
- 5) Rigid grooved couplings listed for UL standard UL 213 may use max brace spacings.
- 6) Max gravity support spacing based on 2013 California Plumbing Code Table 313.3.

RMC CONDUIT

$(E_V = 0.3 W_p)$

Maximum Brace Spacing (ft.) [I_T or I_L^2]								
Nom. Dia. (in.)	F_p/W_p (ASD)	Max Vertical Support Spacing	0.5 or less	1	1.5	2	2.5	3
½	10	10	17	14	13	12	11	11
¾	10	10	19	16	14	13	12	12
1	10	10	21	17	16	15	14	13
1¼	10	10	23	19	17	16	15	15
1½	10	10	24	20	18	17	16	15
2	10	10	27	22	20	19	18	17
2½	10	10	29	25	22	21	20	19
3	10	10	32	27	24	23	22	21
3½	10	10	34	28	25	24	22	21
4	10	10	35	30	27	25	24	23

- 1) Includes conduit and conductors (see appendix).
- 2) For longitudinal (I_L) & all-directional brace spacing, multiply the tabulated values by 3. Brace and/or connector capacity may govern max spacings in some cases.
- 3) Couplings connecting RMC segments shall be designed or tested to accept seismic loads when threaded couplings are not used and may limit the brace spacings to the manufacturer's ratings. The manufacturer's ratings must be based on reviewed capacities and approved by OSHPD.
- 3) Rigid grooved couplings listed for UL STD 213 may use max brace spacings.
- 4) Brace spacing is based on ASCE 7-10 §13.6.8(b); 70% of min. specified yield strength (steel tubing with threaded connections). RMC steel tubing constructed to UL-6 or ANSI C-80.1 with $F_y = 30$ ksi min.



16100 S. Lathrop Ave
Harvey, IL 60426
Toll-Free: (800) 882-5543

www.unistrutseismic.com

Rami Elhassan

Structural Engineer: Rami Elhassan
California SE No. 3930

Page:

1m.1

Max Transverse (I_T) & Longitudinal (I_L) Brace Spacing

IMC CONDUIT

$(E_v = 0.3 W_p)$

Maximum Brace Spacing (ft.) [I_T or I_L^2]

Nom. Dia. (in.) \ F_p/W_p (ASD)	Max Vertical Support Spacing	0.5 or less	1	1.5	2	2.5	3
1	10	15	12	11	10	10	9
¾	10	17	14	13	12	11	11
1	10	18	15	14	13	12	12
1¼	10	21	17	16	15	14	13
1½	10	21	18	16	15	14	14
2	10	23	19	18	16	16	15
2½	10	26	21	19	18	17	16
3	10	27	23	21	19	18	17
3½	10	29	24	22	20	19	18
4	10	30	25	23	21	20	19

- 1) Includes conduit and conductors (see appendix).
- 2) For longitudinal (I_L) & all-directional brace spacing, multiply the tabulated values by 3. Brace and/or connector capacity may govern max spacings in some cases.
- 3) Couplings connecting IMC segments shall be designed or tested to accept seismic loads when threaded couplings are not used and may limit the brace spacings to the manufacturer's ratings. The manufacturer's ratings must be based on reviewed capacities and approved by OSHPD.
- 3) Rigid grooved couplings listed for UL STD 213 may use max brace spacings.
- 4) Brace spacing is based on ASCE 7-10 §13.6.8(b): 70% of min. specified yield strength (steel tubing with threaded connections). IMC steel tubing constructed to UL-1242 or ANSI C-80.6 with $F_y = 30$ ksi min.

EMT CONDUIT

$(E_v = 0.3 W_p)$

Maximum Brace Spacing (ft.) [I_T or I_L^2]

Nom. Dia. (in.) \ F_p/W_p (ASD)	Max Vertical Support Spacing	0.5 or less	1	1.5	2	2.5	3
1	10	15	12	11	10	10	9
¾	10	17	14	13	12	11	11
1	10	18	15	14	13	12	12
1¼	10	21	17	16	15	14	13
1½	10	21	18	16	15	14	14
2	10	23	19	18	16	16	15
2½	10	26	21	19	18	17	16
3	10	27	23	21	19	18	17
3½	10	29	24	22	20	19	18
4	10	30	25	23	21	20	19

- 1) Includes conduit and conductors (see appendix).
- 2) For longitudinal (I_L) & all-directional brace spacing, multiply the tabulated values by 3. Brace and/or connector capacity may govern max spacings in some cases.
- 3) Couplings for up to 2-1/2" EMT to meet project specs. However, set screw couplings listed to UL 5148 with a minimum of (2) set screws each side of the splice shall be used for 3", 3-1/2" and 4" EMT.
- 4) Brace spacings are based on EMT steel tubing listed to UL-797 and manufactured in accordance with ANSI C80.3 with $F_y = 30$ ksi min.
- 5) Max brace spacing is based on ASCE 7-10 Section 13.6.8 note b. 70% of the material minimum specified tensile strength for steel tubing.

COPPER TYPE K

$(E_v = 0.3 W_p)$

Maximum Brace Spacing (ft.) [I_T or I_L^2]

Nom. Dia. (in.) \ F_p/W_p (ASD)	Max Vertical Support Spacing	0.5 or less	1	1.5	2	2.5	3
¾	5	10	8	7	7	6	6
½	5	11	9	8	7	7	7
⅝	5	12	10	9	8	8	7
¾	5	13	11	10	9	9	8
1	6	15	12	11	10	10	9
1¼	7	16	14	12	11	11	10
1½	8	18	15	14	13	12	11
2	8	21	17	16	15	14	13
2½	9	23	19	17	16	15	15
3	10	25	21	19	18	17	16
3½	10	27	23	21	19	18	17
4	10	29	24	22	21	19	19

- 1) Includes pipe, water and insulation (see appendix).
- 2) For longitudinal (I_L) & all-directional brace spacing, multiply the tabulated values by 3. Brace and/or connector capacity may govern max spacings in some cases.
- 3) Joints shall be soldered.
- 4) Piping in accordance with ASME B31.
- 5) Brace spacings are based on pipe conforming to ASTM B88 Type K drawn copper with soldered joints.

COPPER TYPE L

$(E_v = 0.3 W_p)$

Maximum Brace Spacing (ft.) [I_T or I_L^2]

Nom. Dia. (in.) \ F_p/W_p (ASD)	Max Vertical Support Spacing	0.5 or less	1	1.5	2	2.5	3
¾	5	9	8	7	6	6	6
½	5	10	9	8	7	7	7
⅝	5	11	10	9	8	8	7
¾	5	12	10	9	9	8	8
1	6	14	12	11	10	9	9
1¼	7	16	13	12	11	11	10
1½	8	17	15	13	12	12	11
2	8	20	17	15	14	14	13
2½	9	23	19	17	16	15	14
3	10	25	21	19	17	17	16
3½	10	27	22	20	19	18	17
4	10	28	24	22	20	19	18

- 1) Includes pipe, water and insulation (see appendix).
- 2) For longitudinal (I_L) & all-directional brace spacing, multiply the tabulated values by 3. Brace and/or connector capacity may govern max spacings in some cases.
- 3) Joints shall be soldered.
- 4) Piping in accordance with ASME B31.
- 5) Brace spacings are based on pipe conforming to ASTM B88 Type L drawn copper with soldered joints.



16100 S. Lathrop Ave
Harvey, IL 60426
Toll-Free: (800) 882-5543

www.unistrutseismic.com

Rami Elhassan
Structural Engineer: Rami Elhassan
California SE No. 3930

Page:

1m.2

Max Transverse (I_T) & Longitudinal (I_L) Brace Spacing

COPPER TYPE M

$(E_v = 0.3 W_p)$

Maximum Brace Spacing (ft.) [I_T or I_L^2]								
Nom. Dia. (in.)	F_p/W_p (ASD)	Max Vertical Support Spacing	0.5 or less	1	1.5	2	2.5	3
3/8		5	9	7	7	6	6	6
1/2		5	10	8	7	7	7	6
5/8		5	13	11	10	9	9	8
3/4		5	12	10	9	8	8	7
1		6	13	11	10	10	9	9
1 1/4		7	15	13	12	11	10	10
1 1/2		8	17	14	13	12	11	11
2		8	20	17	15	14	13	13
2 1/2		9	22	18	17	15	15	14
3		10	24	20	18	17	16	15
3 1/2		10	26	22	20	18	17	17
4		10	28	23	21	20	19	18

- 1) Includes pipe, water and insulation (see appendix).
- 2) For longitudinal (I_L) & all-directional brace spacing, multiply the tabulated values by 3. Brace and/or connector capacity may govern max spacings in some cases.
- 3) Joints shall be soldered.
- 4) Piping in accordance with ASME B31.
- 5) Brace spacings are based on pipe conforming to ASTM B88 Type M drawn copper with soldered joints.

NO-HUB CAST IRON PIPE

$(E_v = 0.3 W_p)$

Maximum Brace Spacing (ft.) [I_T or I_L^2]								
Nom. Dia. (in.)	F_p/W_p (ASD)	Max ⁶ Vertical Support Spacing	0.5 or less	1	1.5	2	2.5	3
1 1/2		10	10	10	10	10	10	10
2		10	10	10	10	10	10	10
3		10	10	10	10	10	10	10
4		10	10	10	10	10	10	10
5		10	10	10	10	10	10	10
6		10	10	10	10	10	10	10
8		10	10	10	10	10	10	10

- 1) Includes pipe and water (see appendix).
- 2) For longitudinal (I_L) & all-directional brace spacing, multiply the tabulated values by 2. Brace and/or connector capacity may govern max spacings in some cases.
- 3) See note 7 on page 1i.2.
- 4) Joints shall be heavy duty coupling with 4/6 bands
- 5) The max brace spacing is based on the type of couplings used, using only 10% of the material specified tensile strength, with material conforming to ASTM A888 and having a minimum tensile strength of Ft = 20 ksi.
- 6) Max spacing is based on standard 10 ft pipe length segments supported within 18" in each direction from a joint connection.
- 7) Brace and/or connection capacity may govern max spacing in some cases.
- 8) Design to be by the RDP or SEOR for the gray hatched section.

DUCTWORK: The maximum transverse brace spacing (I_T) is 30 feet and the maximum longitudinal brace spacing (I_L) is 60 feet.

CABLE TRAY: Cable tray shall be approved on a project specific basis, or preapproved by OSHPD. Spacing limits set by the manufacturer shall not be exceeded. Cable Tray brace spacing shall be approved or preapproved by OSHPD.

Atkore
Unistrut

16100 S. Lathrop Ave
Harvey, IL 60426
Toll-Free: (800) 882-5543

www.unistrutseismic.com

Rami Elhassan
Structural Engineer: Rami Elhassan
California SE No. 3930

Page:

1m.3

Pre-Designed Solutions

Type	Page
Pre-Designed Solution Instructions	2a.1
Pre-Designed Solution Diagrams (Single Pipe, Conduit or Tube)	2b.1 – 2b.2
Pre-Designed Solutions (Schedule 10, 40 & 80 Steel Pipe)	2c.1 – 2c.3
Pre-Designed Solutions (No-Hub Cast Iron Steel Pipe)	2d.1 – 2d.3
Pre-Designed Solutions (Conduit - RMC & IMC)	2e.1 – 2e.3
Pre-Designed Solutions (Conduit - EMT)	2f.1 – 2f.3
Pre-Designed Solutions (Copper Pipe & Tube - Type K & L)	2g.1 – 2g.3
Pre-Designed Solution Diagrams (Trapeze Supported Pipe, Conduit, Cable Tray & Ductwork)	2h.1 – 2h.2
Pre-Designed Solutions (Trapeze Supported Pipe, Conduit, Cable Tray & Ductwork)	2i.1 – 2i.3

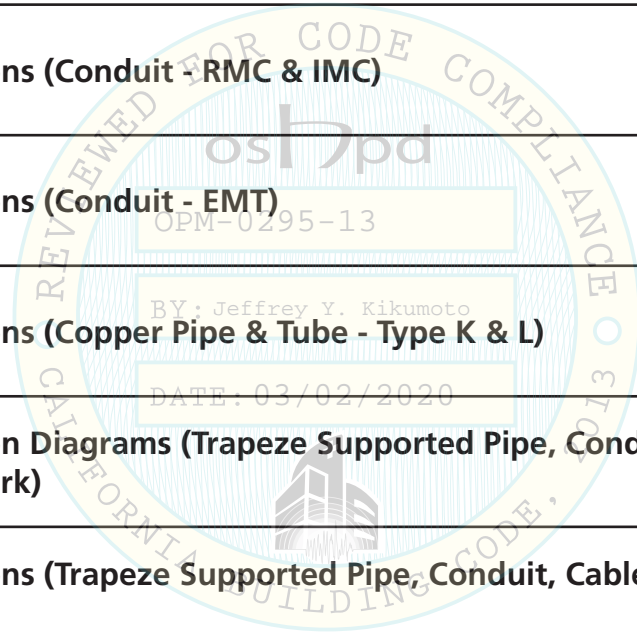

16100 S. Lathrop Ave
Harvey, IL 60426
Toll-Free: (800) 882-5543

www.unistrutseismic.com

Structural Engineer: Rami Elhassan
California SE No. 3930

Page:

2a.0

Pre-Designed Solution Instructions

SECTION 2 – PRE-DESIGN SOLUTION INSTRUCTIONS:

1. Determine the material/system to be braced per Page 1g.1.
2. Calculate F_p per Page 1i.2.
3. Locate the pre-design table corresponding to the material and the calculated F_p/W_p as provided in sections 2c through 2i (see note 1).
4. Use the pre-design table located in the previous step to determine the required brace design information provided in columns I through IX for the diameter of pipe/conduit being braced.
5. See design example in Section 8.

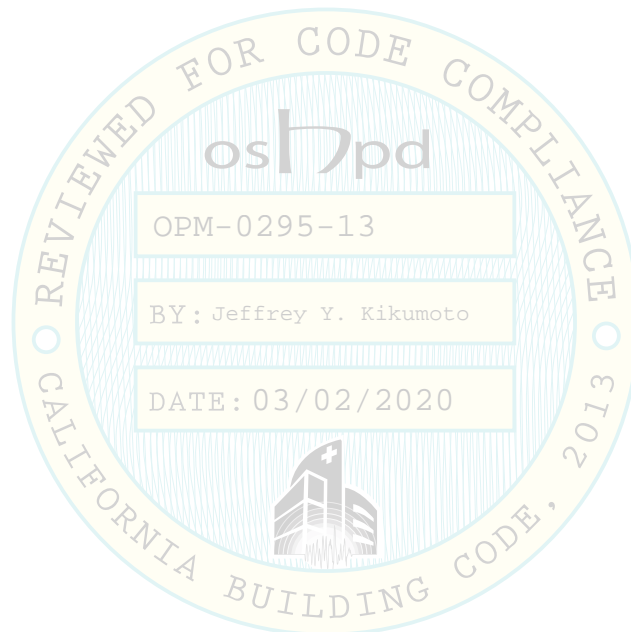

Notes:

1. The calculated F_p shall not exceed the maximum lateral acceleration coefficient (F_p/W_p) for each table.
2. Section 2 – Pre-Design Solutions should not be used for materials not included in pre-design tables, or if the calculated F_p exceeds 0.55g.
3. See Section 3 for restraint type details for additional information and required information needed for a complete brace design.
4. See Section 1 for additional requirements.

Atkore[™]
Unistrut

16100 S. Lathrop Ave
Harvey, IL 60426
Toll-Free: (800) 882-5543

www.unistrutseismic.com



Structural Engineer: Rami Elhassan
California SE No. 3930

Page:

2a.1

Pre-Designed Solution Diagrams (Single Pipe, Conduit or Tube)

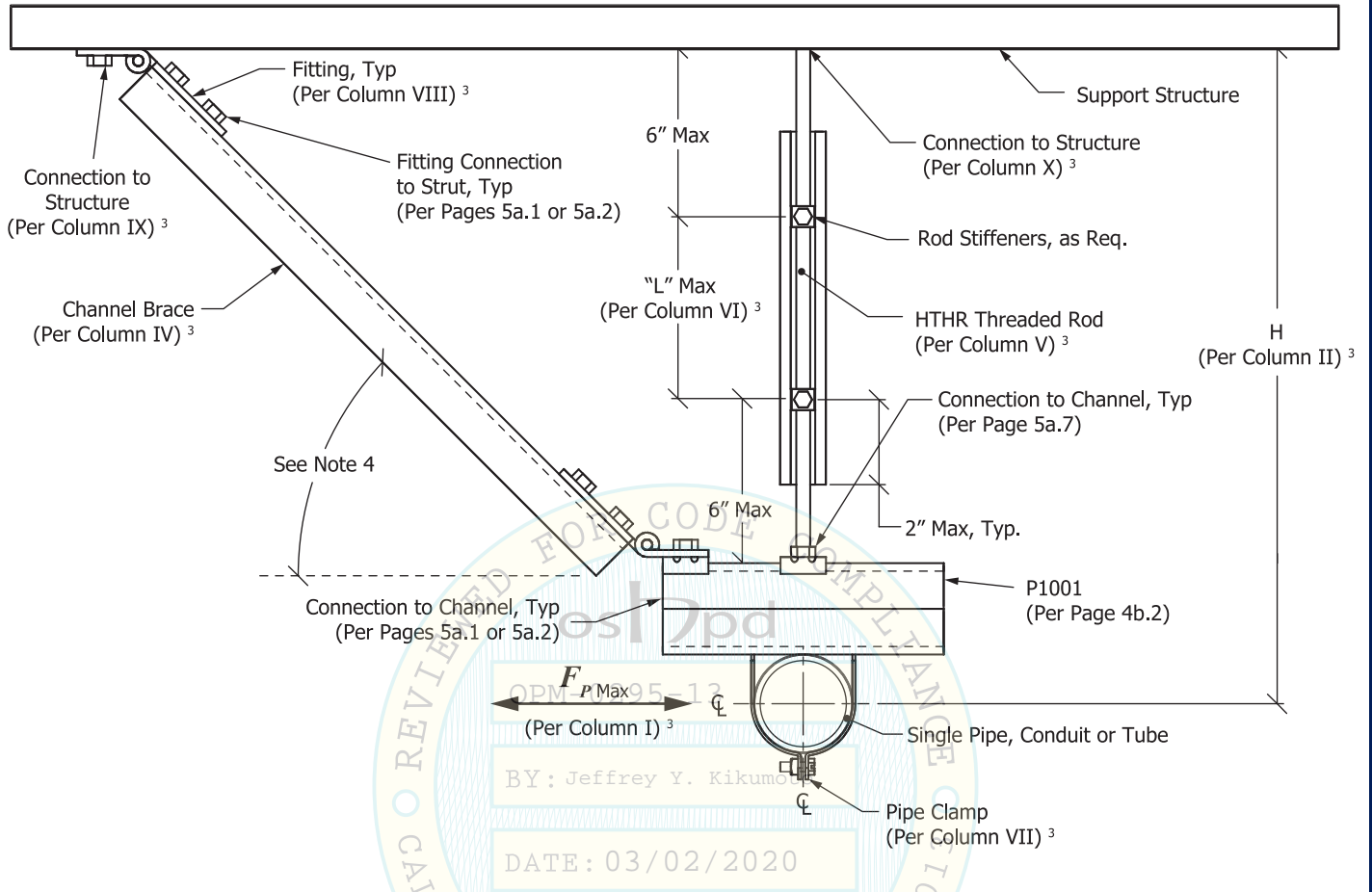
SINGLE PIPE, CONDUIT OR TUBE TRANSVERSE RESTRAINT TYPE:



Notes:

- 1) F_p shall be calculated for each case. F_p shall not exceed the maximum capacities for any of the components used to support the system.
2. Maximum pipe, conduit or tube size per General Notes (Page 1g.1). See Appendix for weight of pipe, conduit and tube.
3. Refer to pages 2c.1 through 2g.3 for column information.
4. Braces can be installed at angles 0° to 60° from horizontal.
5. Fittings and Hardware shown are for graphical representation only. Final configuration may use any fitting or hardware component included in this OPM provided it has sufficient capacity and is used for its correct intent.

Atkore
Unistrut

16100 S. Lathrop Ave
Harvey, IL 60426
Toll-Free: (800) 882-5543

www.unistrutseismic.com

Rami Elhassan
Structural Engineer: Rami Elhassan
California SE No. 3930

Page:

2b.1

Pre-Designed Solution Diagrams (Single Pipe, Conduit or Tube)

SINGLE PIPE, CONDUIT OR TUBE LONGITUDINAL RESTRAINT TYPE:

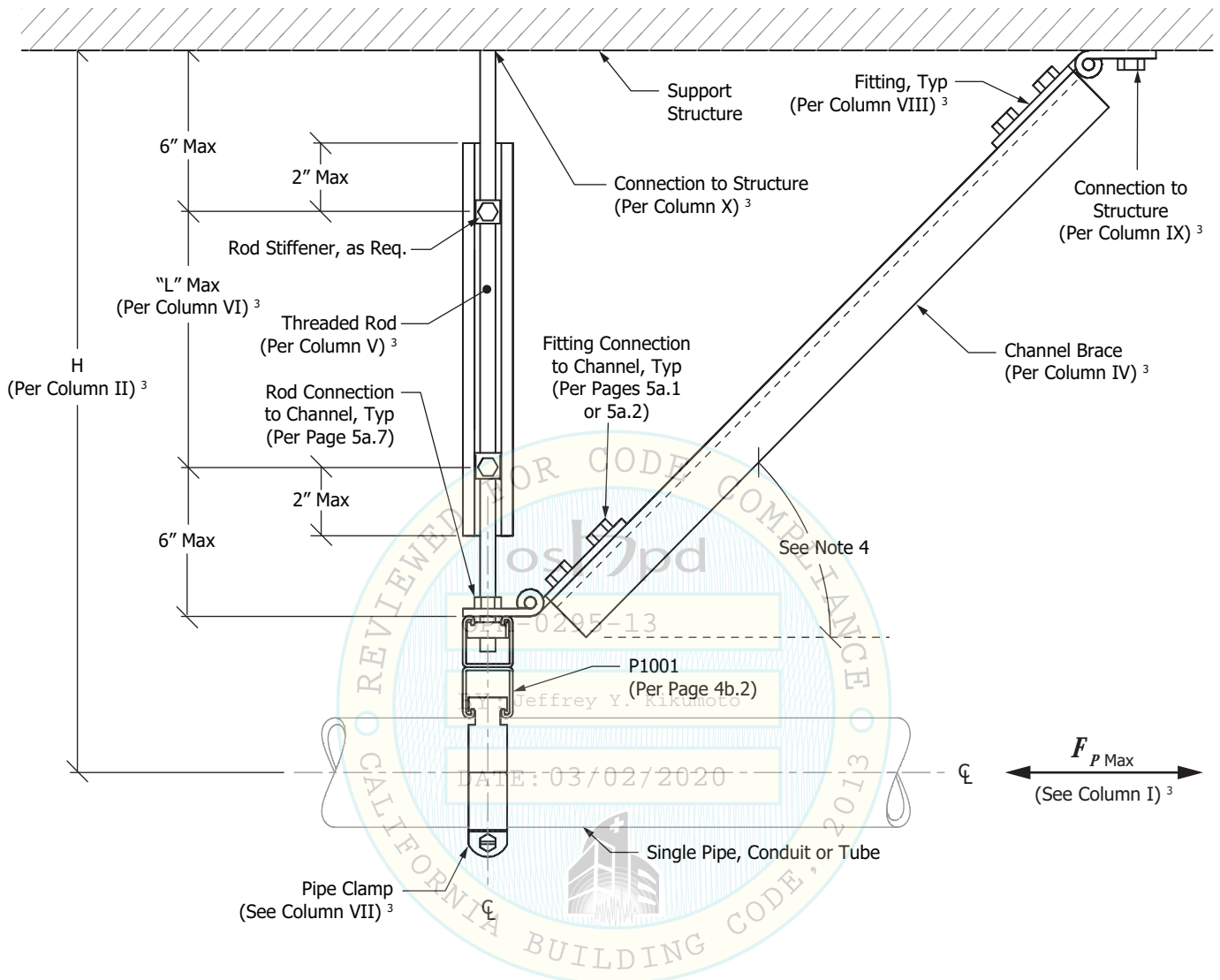

Notes:

- 1) F_p shall be calculated for each case. F_p shall not exceed the maximum capacities for any of the components used to support the system.
- 2) Maximum pipe or conduit size per General Notes (Page 1g.1). See Appendix for weight of pipe, conduit and tube.
- 3) Refer to pages 2c.1 through 2g.3 for column information.
- 4) Braces can be installed at angles 0° to 60° from horizontal.
- 5) Fittings and Hardware shown are for graphical representation only. Final configuration may use any fitting or hardware component included in this OPM provided it has sufficient capacity and is used for its correct intent.

Atkore™
Unistrut

16100 S. Lathrop Ave
Harvey, IL 60426
Toll-Free: (800) 882-5543

www.unistrutseismic.com

Rami Elhassan
Structural Engineer: Rami Elhassan
California SE No. 3930

Page:

2b.2

Pre-Designed Solutions (Schedule 10, 40 & 80 Steel Pipe)

SCH. 10, 40 & 80 STEEL PIPE

MAX LATERAL FORCE $F_p = 0.25W_p$ (ASD)

MAX VERTICAL FORCE $E_v = 0.25W_p$ (ASD)

MAXIMUM BRACE ANGLE = 60° FROM HORIZONTAL

$a_p = 2.5$ $R_p = 6$

							I	II	III	IV	V	VI	VII	VIII	IX	X
Diameter (in.)	Max Weight	Max Brace Spacing (ft.)	Max Vertical Support Spacing (ft.) ⁵	Gravity Weight (lbs.)	E_p (ASD) (lbs.)	W_p (lbs.)	F_p (ASD) (lbs.)	H Max (ft.)	Max Brace Length (ft.)	Min Brace Size	Min Vertical Rod Diameter Size	Max Rod Stiffener Spacing "L" (in.)	Pipe Clamp	Fitting	Brace Connection to Structure	Vertical Rod Connection to Structure
1	3.20 plf	19	10	32.00	8.00	60.80	15.20	9.06	10	P1000	3/8"	30	P1113	See Note 1	See Note 2	See Note 3
1¼	4.40 plf	22	10	44.00	11.00	96.80	24.20	9.06	10	P1000	3/8"	30	P1114			
1½	5.40 plf	23	10	54.00	13.50	124.20	31.05	9.06	10	P1000	3/8"	30	P1115			
2	7.40 plf	26	10	74.00	18.50	192.40	48.10	9.06	10	P1000	3/8"	27	P1117			
2½	10.80 plf	29	10	108.00	27.00	313.20	78.30	9.06	10	P1000	3/8"	21	P1118			
3	14.50 plf	32	10	145.00	36.25	464.00	116.00	9.06	10	P1000	3/8"	18	P1119			
3½	17.90 plf	34	10	179.00	44.75	608.60	152.15	9.06	10	P1000	3/8"	15	P1120			
4	21.80 plf	30	10	218.00	54.50	654.00	163.50	9.06	10	P1000	3/8"	15	P1121			
5	31.70 plf	25	10	317.00	79.25	792.50	198.13	9.06	10	P1000	3/8"	12	P1123			
6	43.30 plf	25	10	413.00	108.25	1,082.5	270.63	9.06	10	P1000	3/8"	12	P1124			
8	67.40 plf	20	10	674.00	168.50	1,348.0	337.00	9.06	10	P1000	3/8"	9	P1126			

Notes:

1. All fittings shown in Section 5 are acceptable to be used with the pipe diameters in the table above, except for fitting SPF 200 for 8" diameter nominal pipe size.
2. All types of connections shown in Section 7 are acceptable to be used with the pipe diameters in the table above with the following exceptions:
 - a. 3.5" Diameter Pipe:
 - i. (1) 1/2" diameter anchor w/ 2 1/4" EMB. into LWC
 - b. 4" and 5" Diameter Pipe:
 - i. (1) 1/2" diameter anchor w/ 2 1/4" EMB. into LWC
 - ii. (1) 5/8" diameter anchor w/ 3 1/4" EMB. into LWC
 - c. 6" Diameter Pipe:
 - i. (1) 1/2" diameter anchor w/ 2 1/4" EMB. into either LWC or NWC
 - ii. (1) 1/2" diameter anchor w/ 3 1/4" EMB. into LWC
 - iii. (1) 5/8" diameter anchor w/ 3 1/4" EMB. into LWC
 - iv. (2) 3/8" diameter anchors w/ 2" EMB. into LWC
 - d. 8" Diameter Pipe:
 - i. (1) 1/2" diameter anchor w/ 2 1/4" EMB. into either LWC or NWC
 - ii. (1) 1/2" diameter anchor w/ 3 1/4" EMB. into LWC
 - iii. (1) 5/8" diameter anchor w/ 3 1/4" EMB. into LWC
 - iv. (2) 3/8" diameter anchors w/ 2" EMB. into LWC
 - v. (2) 1/2" diameter anchors w. 3 1/4" EMB. into LWC
3. See Note 3.1 for pipe sizes up to 3.5" Diameter; See Note 3.2 for pipe sizes larger than 3.5" Diameter.
 - 3.1. For pipe sizes up to 3.5" Diameter as tabulated above, all types of connections shown in Section 7 are acceptable to be used with the following exceptions:
 - a. 3" Diameter Pipe:
 - i. (1) 3/8" diameter anchor w/ 2" EMB. into LWC
 - ii. (1) 1/2" diameter anchor w/ 2 1/4" EMB. into LWC
 - b. 3.5" Diameter Pipe:
 - i. (1) 3/8" diameter anchor w/ 2" EMB. into either LWC or NWC.
 - ii. (1) 1/2" diameter anchor w/ 2 1/4" EMB. into LWC
 - iii. (1) 5/8" diameter anchor w/ 3 1/4" EMB. into LWC
 - 3.2. For pipe sizes larger than 3.5" Diameter as tabulated above, only the following connection types are acceptable:
 - a. 4" and 5" Diameter Pipes:
 - i. (1) 1/2" diameter anchor w/ 3 1/4" EMB. into NWC
 - ii. (1) 5/8" diameter anchor w/ 3 1/4" EMB. into NWC, and w/ 4 1/4" EMB. into either NWC or LWC
 - iii. (2) 1/2" diameter bolts w/ 3 1/4" EMB. into LWC.
 - iv. All the (2) anchor bolt connections into NWC.
 - v. Wood connection Detail 7d.2-1.
 - b. 6" and 8" Diameter Pipe:
 - i. (1) 5/8" diameter anchor w/ 4 1/4" EMB. into NWC
 - ii. (2) 1/2" Diameter anchor w/ 3 1/4" EMB. into NWC
4. These tables are based on a maximum S_{DS} of 1.78g. Any S_{DS} above 1.78g requires an RDP or SEOR review.
5. Maximum vertical support spacing is based on 2013 California Plumbing Code, Table 313.1



16100 S. Lathrop Ave
Harvey, IL 60426
Toll-Free: (800) 882-5543

www.unistrutseismic.com

Structural Engineer: Rami Elhassan
California SE No. 3930

Page:

2c.1

Pre-Designed Solutions (Schedule 10, 40 & 80 Steel Pipe)

SCH. 10, 40 & 80 STEEL PIPE

MAX LATERAL FORCE $F_p = 0.40W_p$ (ASD)

MAX VERTICAL FORCE $E_v = 0.25W_p$ (ASD)

MAXIMUM BRACE ANGLE = 60° FROM HORIZONTAL

$a_p = 2.5$ $R_p = 6$

							I	II	III	IV	V	VI	VII	VIII	IX	X
Diameter (in.)	Max Weight	Max Brace Spacing (ft.)	Max Vertical Support Spacing (ft.) ⁵	Gravity Weight (lbs.)	E_{pv} (ASD) (lbs.)	W_p (lbs.)	F_p (ASD) (lbs.)	H Max (ft.)	Max Brace Length (ft.)	Min Brace Size	Min Vertical Rod Diameter Size	Max Rod Stiffener Spacing "L" (in.)	Pipe Clamp	Fitting	Brace Connection to Structure	Vertical Rod Connection to Structure
1	3.20 plf	19	10	32.00	8.00	60.80	24.32	9.06	10	P1000	3/8"	30	P1113	See Note 1	See Note 2	See Note 3
1¼	4.40 plf	22	10	44.00	11.00	96.80	38.72	9.06	10	P1000	3/8"	30	P1114			
1½	5.40 plf	23	10	54.00	13.50	124.20	49.68	9.06	10	P1000	3/8"	27	P1115			
2	7.40 plf	26	10	74.00	18.50	192.40	76.96	9.06	10	P1000	3/8"	21	P1117			
2½	10.80 plf	29	10	108.00	27.00	313.20	125.28	9.06	10	P1000	3/8"	15	P1118			
3	14.50 plf	32	10	145.00	36.25	464.00	185.60	9.06	10	P1000	3/8"	12	P1119			
3½	17.90 plf	34	10	179.00	44.75	608.60	243.44	9.06	10	P1000	3/8"	12	P1120			
4	21.80 plf	30	10	218.00	54.50	654.00	261.60	9.06	10	P1000	3/8"	12	P1121			
5	31.70 plf	25	10	317.00	79.25	792.50	317.00	9.06	10	P1000	½"	18	P1123			
6	43.30 plf	20	10	433.00	108.25	866.00	346.40	9.06	10	P1000	½"	18	P1124			
8	67.40 plf	12	10	674.00	168.50	808.00	323.52	9.06	10	P1000	½"	18	P1126			

Notes:

1. All fittings shown in Section 5 are acceptable to be used with the pipe diameters in the table above, except for fitting SPF 200 for 6" diameter nominal pipe size.
 - a. 2.5" Diameter Pipe:
 - i. (1) 3/8" diameter anchor w/ 2" EMB. into LWC
 - ii. (1) 1/2" diameter anchor w/ 2 1/4" EMB. into LWC
 - b. 3" Diameter Pipe:
 - i. (1) 3/8" diameter anchor w/ 2" EMB. into either LWC or NWC
 - ii. (1) 1/2" diameter anchor w/ 2 1/4" EMB. into LWC
 - iii. (1) 5/8" diameter anchor w/ 3 1/4" EMB. into LWC
 - c. 3.5" and 4" Diameter Pipe:
 - i. (1) 1/2" diameter anchor w/ 2 1/4" EMB. into either LWC or NWC
 - ii. (1) 1/2" diameter anchor w/ 3 1/4" EMB. into LWC
 - iii. (1) 5/8" diameter anchor w/ 3 1/4" EMB. into LWC
 - iv. (2) 3/8" diameter anchors w/ 2" EMB. into LWC
 - d. 5", 6" and 8" Diameter Pipes:
 - i. (1) 1/2" diameter anchor w/ 2 1/4" EMB. into either LWC or NWC
 - ii. (1) 1/2" diameter anchor w/ 3 1/4" EMB. into LWC
 - iii. (1) 5/8" diameter anchor w/ 3 1/4" EMB. into LWC
 - iv. (2) 3/8" diameter anchors w/ 2" EMB. into LWC
 - v. (2) 1/2" diameter anchors w/ 2 1/4" EMB. into LWC
2. All types of connections shown in Section 7 are acceptable to be used with the pipe diameters in the table above with the following exceptions:
 - a. 2.5" Diameter Pipe:
 - i. (1) 3/8" diameter anchor w/ 2" EMB. into LWC
 - ii. (1) 1/2" diameter anchor w/ 2 1/4" EMB. into LWC
 - b. 3" Diameter Pipe:
 - i. (1) 3/8" diameter anchor w/ 2" EMB. into either LWC or NWC
 - ii. (1) 1/2" diameter anchor w/ 2 1/4" EMB. into LWC
 - iii. (1) 5/8" diameter anchor w/ 3 1/4" EMB. into LWC
 - c. 3.5" Diameter Pipe:
 - i. (1) 3/8" diameter anchor w/ 2" EMB. into either LWC or NWC.
 - ii. (1) 1/2" diameter anchor w/ 2 1/4" EMB. into either LWC or NWC.
 - iii. (1) 1/2" diameter anchor w/ 3 1/4" EMB. into LWC.
 - iv. (1) 5/8" diameter anchor w/ 3 1/4" EMB. into LWC
 - v. (2) 3/8" diameter anchors w/ 2" EMB. into LWC
 - vi. (2) 1/2" diameter anchors w/ 2 1/4" EMB. into LWC
 - vii. Wood connection Detail 7d.2-1
 - 3.2. For pipe sizes larger than 3.5" Diameter as tabulated above, only the following connection types are acceptable:
 - a. 4" and 5" Diameter Pipes:
 - i. (1) 5/8" diameter anchor w/ 4 1/4" EMB. into LWC
 - ii. (1) 1/2" diameter bolts w/ 3 1/4" EMB., (1) 5/8" diameter anchor bolt with 3 1/4" or 4 1/4" EMB. into NWC.
 - iii. (2) 1/2" diameter bolts w/ 3 1/4" EMB. into NWC.
 - b. 6" and 8" Diameter Pipe:
 - i. (1) 5/8" diameter anchor w/ 4 1/4" EMB. into NWC
 - ii. (2) 1/2" diameter anchor w/ 3 1/4" EMB. into NWC
3. See Note 3.1 for pipe sizes up to 3.5" Diameter; See Note 3.2 for pipe sizes larger than 3.5" Diameter.
 - 3.1 For pipe sizes up to 3.5" Diameter as tabulated above, all types of connections show in Section 7 are acceptable to be used with the following exceptions:
4. These tables are based on a maximum S_{ps} of 1.78g. Any S_{ps} above 1.78g requires an RDP or SEOR review.
5. Maximum vertical support spacing is based on 2013 California Plumbing Code, Table 313.1



16100 S. Lathrop Ave
Harvey, IL 60426
Toll-Free: (800) 882-5543

www.unistrutseismic.com

Rami Elhassan
Structural Engineer: Rami Elhassan
California SE No. 3930

Page:

2c.2

Pre-Designed Solutions (Schedule 10, 40 & 80 Steel Pipe)

SCH. 10, 40 & 80 STEEL PIPE

MAX LATERAL FORCE $F_p = 0.55W_p$ (ASD)

MAX VERTICAL FORCE $E_v = 0.25W_p$ (ASD)

MAXIMUM BRACE ANGLE = 60° FROM HORIZONTAL

$a_p = 2.5$ $R_p = 6$

Diameter (in.)	Max Weight	Max Brace Spacing (ft.)	Max Vertical Support Spacing (ft.) ⁵	Gravity Weight (lbs.)	F_m (ASD) (lbs.)	W_p (lbs.)	I	II	III	IV	V	VI	VII	VIII	IX	X
							F_p (ASD) (lbs.)	H Max (ft.)	Max Brace Length (ft.)	Min Brace Size	Min Vertical Rod Diameter Size	Max Rod Stiffener Spacing "L" (in.)	Pipe Clamp	Fitting	Brace Connection to Structure	Vertical Rod Connection to Structure
1	3.20 plf	19	10	32.00	8.00	60.80	33.44	9.06	10	P1000	3/8"	30	P1113	See Note 1	See Note 2	See Note 3
1¼	4.40 plf	22	10	44.00	11.00	96.80	53.24	9.06	10	P1000	3/8"	27	P1114			
1½	5.40 plf	23	10	54.00	13.50	124.20	68.31	9.06	10	P1000	3/8"	24	P1115			
2	7.40 plf	26	10	74.00	18.50	192.40	105.82	9.06	10	P1000	3/8"	18	P1117			
2½	10.80 plf	29	10	108.00	27.00	313.20	172.26	9.06	10	P1000	3/8"	15	P1118			
3	14.50 plf	32	10	145.00	36.25	464.00	255.20	9.06	10	P1000	3/8"	12	P1119			
3½	17.90 plf	34	10	179.00	44.75	608.60	334.73	9.06	10	P1000	½"	18	P1120			
4	21.80 plf	30	10	218.00	54.50	654.00	359.70	9.06	10	P1000	½"	18	P1121			
5	31.70 plf	20	10	317.00	79.25	634.00	348.70	9.06	10	P1000	½"	18	P1123			
6	43.30 plf	15	10	433.00	108.25	649.50	357.23	9.06	10	P1000	½"	18	P1124			
8	67.40 plf	10	10	674.00	168.50	674.00	370.70	9.06	10	P1000	½"	18	P1126			

Notes:

1. All fittings shown in Section 5 are acceptable to be used with the pipe diameters in the table above, except for fitting SPF 200 for 3.5" diameter nominal pipe size.
2. All types of connections show in Section 7 are acceptable to be used with the pipe diameters in the table above with the following exceptions:
 - a. 2.5" Diameter Pipe:
 - i. (1) 1/2" diameter anchor w/ 2 1/4" EMB. into LWC
 - ii. (1) 5/8" diameter anchor w/ 3 1/4" EMB. into LWC
 - b. 3" and 3.5" Diameter Pipes:
 - i. (1) 3/8" diameter anchor w/ 2" EMB. into either LWC or NWC
 - ii. (1) 1/2" diameter anchor w/ 2 1/4" EMB. into either LWC or NWC.
 - iii. (1) 1/2" diameter anchor w/ 3 1/4" EMB. into LWC
 - iv. (1) 5/8" diameter anchor w/ 3 1/4" EMB. into LWC
 - v. (2) 3/8" diameter anchor w/ 2" EMB. into LWC
 - vi. (2) 1/2" diameter anchor w/ 2 1/4" EMB. into LWC
 - vii. Wood connection Detail 7d.2-1
 - c. 3.5", 4", 5", 6" and 8" Diameter Pipes:
 - i. (1) 1/2" diameter anchor w/ 2 1/4" EMB into either LWC or NWC
 - ii. (1) 1/2" diameter anchor w/ 3 1/4" EMB. into LWC
 - iii. (1) 5/8" diameter anchor w/ 3 1/4" EMB. into LWC
 - iv. (2) 3/8" diameter anchors w/ 2" EMB. into LWC
 - v. (2) 1/2" diameter anchors w/ 2 1/4" EMB. into LWC
3. See Note 3.1 for pipe sizes up to 3.5" Diameter; See Note 3.2 for pipe sizes larger than 3.5" Diameter.
 - 3.1. For pipe sizes up to 3.5" Diameter as tabulated above, all types of connections show in Section 7 are acceptable to be used with the following exceptions:
 - a. 2.5" Diameter Pipe:
 - i. (1) 3/8" diameter anchor w/ 2" EMB. into LWC
 - ii. (1) 1/2" diameter anchor w/ 2 1/4" EMB. into LWC
 - iii. (1) 5/8" diameter anchor w/ 3 1/4" EMB. into LWC
 - b. 3" and 3.5" Diameter Pipes:
 - i. (1) 3/8" diameter anchor w/ 2" EMB. into either LWC or NWC
 - ii. (1) 1/2" diameter anchor w/ 2 1/4" EMB. into either LWC or NWC.
 - iii. (1) 1/2" diameter anchor w/ 3 1/4" EMB. into LWC
 - iv. (1) 5/8" diameter anchor w/ 3 1/4" EMB. into LWC
 - v. (2) 3/8" diameter anchor w/ 2" EMB. into LWC
 - vi. (2) 1/2" diameter anchor w/ 2 1/4" EMB. into LWC
 - vii. Wood connection Detail 7d.2-1
 - 3.2. For pipe sizes larger than 3.5" Diameter as tabulated above, only the following connection types are acceptable:
 - a. 4" and 5" Diameter Pipes:
 - i. (1) 1/2" diameter bolts w/ 3 1/4" EMB., (1) 5/8" diameter anchor bolt with 3 1/4" or 4 1/4" EMB. into NWC
 - ii. (2) 1/2" diameter bolts w/ 3 1/4" EMB. into NWC
 - b. 6" and 8" Diameter Pipe:
 - i. (1) 5/8" diameter anchor w/ 4 1/4" EMB. into NWC
 - ii. (2) 1/2" diameter anchor w/ 3 1/4" EMB. into NWC
4. These tables are based on a maximum S_{DS} of 1.78g. Any S_{DS} above 1.78g requires an RDP or SEOR review.
5. Maximum vertical support spacing is based on 2013 California Plumbing Code, Table 313.1



16100 S. Lathrop Ave
Harvey, IL 60426
Toll-Free: (800) 882-5543

www.unistrutseismic.com

Structural Engineer: Rami Elhassan
California SE No. 3930

Page:

2c.3

Pre-Designed Solutions (No-Hub Cast Iron Steel Pipe)

NO-HUB CAST IRON STEEL PIPE (FILLED WITH WATER)

MAX LATERAL FORCE $F_p = 0.25W_p$ (ASD)

MAX VERTICAL FORCE $E_v = 0.25W_p$ (ASD)

MAXIMUM BRACE ANGLE = 60° FROM HORIZONTAL

$a_p = 2.5$

$R_p = 3.0$

							I	II	III	IV	V	VI	VII	VIII	IX	X
Diameter (in.)	Max Weight	Max Brace Spacing (ft.)	Max Vertical Support Spacing (ft.) ⁶	Gravity Weight (lbs.)	E_p (ASD) (lbs.)	W_p (lbs.)	F_p (ASD) (lbs.)	H Max (ft.)	Max Brace Length (ft.)	Min Brace Size	Min Vertical Rod Diameter Size	Max Rod Stiffener Spacing "L" (in.)	Pipe Clamp	Fitting	Brace Connection to Structure	Vertical Rod Connection to Structure
1½	4.60 plf	10	10	45.95	11.49	45.95	11.49	9.06	10	P1000	¾"	30	P1115	See Note 2	See Note 3	See Note 4
2	6.02 plf	10	10	60.15	15.04	60.15	15.04	9.06	10	P1000	¾"	30	P1117			
3	9.90 plf	10	10	99.00	24.75	99.00	24.75	9.06	10	P1000	¾"	30	P1119			
4	15.54 plf	10	10	155.35	38.84	155.35	38.84	9.06	10	P1000	¾"	30	P1121			
5	18.65 plf	10	10	186.50	46.63	186.50	46.63	9.06	10	P1000	¾"	27	P1123			
6	24.31 plf	10	10	243.05	60.76	243.05	60.76	9.06	10	P1000	¾"	24	P1124			
8	41.53 plf	10	10	415.25	103.81	415.25	103.81	9.06	10	P1000	¾"	18	P1126			

Notes:

- For no-hub cast iron pipes: Each pipe section must include an all-directional seismic brace unless the pipes have a transverse and longitudinal brace within 24 inches of every other coupling, using heavy duty couplings in accordance with ASTM C1540 that have been tested and certified in accordance with FM 1680 Class I, where the transverse brace spacing does not exceed 10' and the longitudinal brace spacing does not exceed 10'.
- All fittings shown in Section 5 are acceptable to be used with the pipe diameters in the table above.
- All types of connections show in Section 7 are acceptable to be used with the pipe diameters in the table above with the following exceptions:
 - 6" Diameter Pipes:
 - (1) ½" diameter anchor w/ 2 ¼" EMB. into LWC
 - 8" Diameter Pipes:
 - (1) ½" diameter anchor w/ 2 ¼" or 3 ¼" EMB. into LWC.
 - (1) 5/8" diameter anchor w/ 3 ¼" EMB. into LWC.
- For pipe as tabulated above, all types of connections show in Section 7 are acceptable to be used with the following exceptions:
 - 4" and 5" Diameter Pipes:
 - (1) 3/8" diameter anchor w/ 2" EMB. into LWC
 - (1) ½" diameter anchor w/ 2 ¼" EMB. into LWC
 - 6" Diameter Pipes:
 - (1) 3/8" diameter anchor w/ 2" EMB. into either LWC or NWC
 - (1) ½" diameter anchor w/ 2 ¼" EMB. into LWC
 - (1) 5/8" diameter anchor w/ 3 ¼" EMB. into LWC
 - Wood connection Detail 7d.2-1
 - 8" Diameter Pipe:
 - (1) 3/8" diameter anchor w/ 2" EMB. into either LWC or NWC
 - (1) ½" diameter anchor w/ 2 ¼" EMB. into either LWC or NWC.
 - (1) ½" or (1) 5/8" diameter anchor w/ 3 ¼" EMB. into LWC
 - (2) 3/8" diameter anchors w/ 2" EMB. into either LWC or NWC
 - (2) ½" diameter anchors w/ 2 ¼" EMB. into LWC
 - Wood connection Detail 7d.2-1
- These tables are based on a maximum S_{DS} of 1.78g. Any S_{DS} above 1.78g requires an RDP or SEOR review.
- Maximum vertical support spacing is based on 2013 California Plumbing Code, Table 313.1

 <p style="text-align: center;">16100 S. Lathrop Ave Harvey, IL 60426 Toll-Free: (800) 882-5543</p> <p style="text-align: center;">www.unistrutseismic.com</p>	 Structural Engineer: Rami Elhassan California SE No. 3930	Page: <h2 style="text-align: center;">2d.1</h2>
	www.unistrutseismic.com	

Pre-Designed Solutions (No-Hub Cast Iron Steel Pipe)

NO-HUB CAST IRON STEEL PIPE (FILLED WITH WATER)

MAX LATERAL FORCE $F_p = 0.40W_p$ (ASD)

MAX VERTICAL FORCE $E_v = 0.25W_p$ (ASD)

MAXIMUM BRACE ANGLE = 60° FROM HORIZONTAL

$$a_p = 2.5$$

$$R_p = 3.0$$

							I	II	III	IV	V	VI	VII	VIII	IX	X
Diameter (in.)	Max Weight	Max Brace Spacing (ft.)	Max Vertical Support Spacing (ft.) ⁶	Gravity Weight (lbs.)	E_p (ASD) (lbs.)	W_p (lbs.)	F_p (ASD) (lbs.)	H Max (ft.)	Max Brace Length (ft.)	Min Brace Size	Min Vertical Rod Diameter Size	Max Rod Stiffener Spacing "L" (in.)	Pipe Clamp	Fitting	Brace Connection to Structure	Vertical Rod Connection to Structure
1½	4.60 plf	10	10	45.95	11.49	45.95	18.38	9.06	10	P1000	¾"	30	P1115	See Note 2	See Note 3	See Note 4
2	6.02 plf	10	10	60.15	15.04	60.15	24.06	9.06	10	P1000	¾"	30	P1117			
3	9.90 plf	10	10	99.00	24.75	99.00	39.60	9.06	10	P1000	¾"	30	P1119			
4	15.54 plf	10	10	155.35	38.84	155.35	62.14	9.06	10	P1000	¾"	24	P1121			
5	18.65 plf	10	10	186.50	46.63	186.50	74.60	9.06	10	P1000	¾"	21	P1123			
6	24.31 plf	10	10	243.05	60.76	243.05	97.22	9.06	10	P1000	¾"	18	P1124			
8	41.53 plf	10	10	415.25	103.81	415.25	166.10	9.06	10	P1000	¾"	15	P1126			

Notes:

- For no-hub cast iron pipes: Each pipe section must include an all-directional seismic brace unless the pipes have a transverse and longitudinal brace within 24 inches of every other coupling, using heavy duty couplings in accordance with ASTM C1540 that have been tested and certified in accordance with FM 1680 Class I, where the transverse brace spacing does not exceed 10' and the longitudinal brace spacing does not exceed 10'.
 - (1) ½" diameter anchor w/ 2 ¼" EMB. into LWC
 - (1) 5/8" diameter anchor w/ 3 ¼" EMB. into LWC
 - (1) 1/2" diameter anchor w/ 2 ¼" EMB. into LWC
 - (1) 5/8" diameter anchor w/ 3 ¼" EMB. into LWC
- All fittings shown in Section 5 are acceptable to be used with the pipe diameters in the table above.
- All types of connections shown in Section 7 are acceptable to be used with the pipe diameters in the table above, except for the following connections:
 - 4" and 5" Diameter Pipe:
 - (1) 1/2" diameter anchor w/ 2 ¼" EMB. into LWC
 - 6" Diameter Pipes:
 - (1) 1/2" diameter anchor w/ 2 ¼" EMB. into LWC
 - (1) 5/8" diameter anchor w/ 3 ¼" EMB. into LWC
 - 8" Diameter Pipes:
 - (1) 1/2" diameter anchor w/ 2 ¼" EMB. into LWC
 - (1) 5/8" diameter anchor w/ 3 ¼" EMB. into LWC
- For pipe as tabulated above, all types of connections show in Section 7 are acceptable to be used with the following exceptions:
 - 4" Diameter Pipes:
 - (1) 3/8" diameter anchor w/ 2" EMB. into LWC
 - (1) 1/2" diameter anchor w/ 2 ¼" EMB. into LWC
 - 5" Diameter Pipes:
 - (1) 3/8" diameter anchor w/ 2" EMB. into either LWC or NWC
 - (1) 1/2" diameter anchor w/ 2 ¼" EMB. into LWC
- These tables are based on a maximum S_{DS} of 1.78g. Any S_{DS} above 1.78g requires an RDP or SEOR review.
- Maximum vertical support spacing is based on 2013 California Plumbing Code, Table 313.1.



16100 S. Lathrop Ave
Harvey, IL 60426
Toll-Free: (800) 882-5543

www.unistrutseismic.com

Structural Engineer: Rami Elhassan
California SE No. 3930

Page:

2d.2

Pre-Designed Solutions (No-Hub Cast Iron Steel Pipe)

NO-HUB CAST IRON STEEL PIPE (FILLED WITH WATER)

MAX LATERAL FORCE $F_p = 0.55W_p$ (ASD)

MAX VERTICAL FORCE $E_v = 0.25W_p$ (ASD)

MAXIMUM BRACE ANGLE = 60° FROM HORIZONTAL

$a_p = 2.5$

$R_p = 3.0$

							I	II	III	IV	V	VI	VII	VIII	IX	X
Diameter (in.)	Max Weight	Max Brace Spacing (ft.)	Max Vertical Support Spacing (ft.) ⁶	Gravity Weight (lbs.)	E_p (ASD) (lbs.)	W_p (lbs.)	F_p (ASD) (lbs.)	H Max (ft.)	Max Brace Length (ft.)	Min Brace Size	Min Vertical Rod Diameter Size	Max Rod Stiffener Spacing "L" (in.)	Pipe Clamp	Fitting	Brace Connection to Structure	Vertical Rod Connection to Structure
1½	4.60 plf	10	10	45.95	11.49	45.95	25.27	9.06	10	P1000	¾"	30	P1115	See Note 2	See Note 3	See Note 4
2	6.02 plf	10	10	60.15	15.04	60.15	33.08	9.06	10	P1000	¾"	30	P1117			
3	9.90 plf	10	10	99.00	24.75	99.00	54.45	9.06	10	P1000	¾"	27	P1119			
4	15.54 plf	10	10	155.35	38.84	155.35	85.44	9.06	10	P1000	¾"	21	P1121			
5	18.65 plf	10	10	186.50	46.63	186.50	102.58	9.06	10	P1000	¾"	18	P1123			
6	24.31 plf	10	10	243.05	60.76	243.05	133.68	9.06	10	P1000	¾"	15	P1124			
8	41.53 plf	10	10	415.25	103.81	415.25	228.39	9.06	10	P1000	¾"	12	P1126			

Notes:

- For no-hub cast iron pipes: Each pipe section must include an all-directional seismic brace unless the pipes have a transverse and longitudinal brace within 24 inches of every other coupling, using heavy duty couplings in accordance with ASTM C1540 that have been tested and certified in accordance with FM 1680 Class I, where the transverse brace spacing does not exceed 10' and the longitudinal brace spacing does not exceed 10'.
- All fittings shown in Section 5 are acceptable to be used with the pipe diameters in the table above.
- All types of connections shown in Section 7 are acceptable to be used with the pipe diameters in the table above, except for the following connections:
 - 4" and 5" Diameter Pipes:
 - (1) ½" diameter anchor w/ 2 ¼" EMB. into LWC
 - (1) ¾" diameter anchor w/ 3 ¼" EMB. into LWC
 - 6" Diameter Pipe:
 - (1) ½" diameter anchor w/ 2 ¼" EMB. into LWC
 - (1) ½" diameter or 5/8" diameter anchor w/ 3 ¼" EMB. into LWC
 - (2) ¾" diameter anchor w/ 2" EMB into LWC
 - 8" Diameter Pipe:
 - (1) ½" diameter anchor w/ 2 ¼" EMB. into either LWC or NWC.
 - (1) ½" diameter or (1) 5/8" diameter anchor w/ 3 ¼" EMB. into LWC
- For pipe as tabulated above, all types of connections show in Section 7 are acceptable to be used with the following exceptions:
 - 3" Diameter Pipes:
 - (1) 3/8" diameter anchor w/ 2" EMB. into LWC
 - (1) ½" diameter anchor w/ 2 ¼" EMB. into LWC
 - 4" Diameter Pipes:
 - (1) 3/8" diameter anchor w/ 2" EMB. into either LWC or NWC
 - (1) ½" diameter anchor w/ 2 ¼" EMB. into LWC
- 5" Diameter Pipes:
 - (1) 3/8" diameter anchor w/ 2" EMB. into either LWC or NWC
 - (1) ½" diameter anchor w/ 2 ¼" EMB. into either LWC or NWC.
 - (1) ½" or (1) 5/8" diameter anchor w/ 3 ¼" EMB. into LWC
 - (2) ¾" diameter anchors w/ 2" EMB. into either LWC or NWC.
 - (2) ½" diameter anchors w/ 2 ¼" EMB. into LWC
 - Wood connection Detail 7d.2-1
- 6" and 8" Diameter Pipes:
 - (1) 3/8" diameter anchor w/ 2" EMB. into either LWC or NWC
 - (1) ½" diameter anchor w/ 2 ¼" EMB. into either LWC or NWC.
 - (1) ½" or (1) 5/8" diameter anchor w/ 3 ¼" EMB. into LWC
 - (2) ¾" diameter anchors w/ 2" EMB. into either LWC or NWC.
 - (2) ½" diameter anchors w/ 2 ¼" EMB. into LWC
 - Wood connection Detail 7d.2-1
- These tables are based on a maximum S_{DS} of 1.78g. Any S_{DS} above 1.78g requires an RDP or SEOR review.
- Maximum vertical support spacing is based on 2013 California Plumbing Code, Table 313.1



16100 S. Lathrop Ave
Harvey, IL 60426
Toll-Free: (800) 882-5543

www.unistrutseismic.com

Structural Engineer: Rami Elhassan
California SE No. 3930

Page:

2d.3

Pre-Designed Solutions (Conduit - RMC & IMC)

CONDUIT - RMC & IMC

MAX LATERAL FORCE $F_p = 0.25W_p$ (ASD)

MAX VERTICAL FORCE $E_v = 0.25W_p$ (ASD)

MAXIMUM BRACE ANGLE = 60° FROM HORIZONTAL

$a_p = 2.5$ $R_p = 6$

							I	II	III	IV	V	VI	VII	VIII	IX	X
Diameter (in.)	Max Weight	Max Brace Spacing (ft.)	Max Vertical Support Spacing (ft.)	Gravity Weight (lbs.)	E_p (ASD) (lbs.)	W_p (lbs.)	F_p (ASD) (lbs.)	H Max (ft.)	Max Brace Length (ft.)	Min Brace Size	Min Vertical Rod Diameter Size	Max Rod Stiffener Spacing "L" (in.)	Pipe Clamp	Fitting	Brace Connection to Structure	Vertical Rod Connection to Structure
1/2	1.04 plf	19	10	10.40	2.60	19.76	4.94	9.06	10	P1000	3/8"	30	P1111	See Note 1	See Note 2	See Note 3
3/4	1.50 plf	21	10	15.00	3.75	31.50	7.88	9.06	10	P1000	3/8"	30	P1112			
1	2.27 plf	23	10	22.70	5.68	52.21	13.05	9.06	10	P1000	3/8"	30	P1113			
1 1/4	3.50 plf	26	10	35.00	8.75	91.00	22.75	9.06	10	P1000	3/8"	30	P1114			
1 1/2	4.40 plf	27	10	44.00	11.00	118.80	29.70	9.06	10	P1000	3/8"	30	P1115			
2	7.02 plf	30	10	70.20	17.55	210.60	52.65	9.06	10	P1000	3/8"	27	P1117			
2 1/2	9.97 plf	34	10	99.70	24.93	338.98	84.75	9.06	10	P1000	3/8"	21	P1118			
3	14.15 plf	36	10	141.50	35.38	509.40	127.35	9.06	10	P1000	3/8"	15	P1119			
3 1/2	17.10 plf	38	10	171.00	42.75	649.80	162.45	9.06	10	P1000	3/8"	15	P1120			
4	20.91 plf	40	10	209.10	52.28	836.40	209.10	9.06	10	P1000	3/8"	12	P1121			
5	29.99 plf	30	10	299.90	74.98	899.70	224.93	9.06	10	P1000	3/8"	12	P1123			
6	42.61 plf	20	10	426.10	106.53	852.20	213.05	9.06	10	P1000	3/8"	12	P1124			

Notes:

- All fittings shown in Section 5 are acceptable to be used with the conduit diameters in the table above.
- All types of connections show in Section 7 are acceptable to be used with the conduit diameters in the table above with the following exceptions:
 - 3" Diameter Conduit:
 - (1) 1/2" diameter anchor w/ 2 1/4" EMB. into LWC
 - 3.5" Diameter Conduit:
 - (1) 1/2" diameter anchor w/ 2 1/4" EMB. into LWC
 - (1) 5/8" diameter anchor w/ 3 1/4" EMB. into LWC
 - 4" Diameter Conduit:
 - (1) 1/2" diameter anchor w/ 2 1/4" EMB. into LWC
 - (1) 1/2" diameter anchor w/ 3 1/4" EMB. into LWC
 - (1) 5/8" diameter anchor w/ 3 1/4" EMB. into LWC
 - 5" and 6" Diameter Conduits:
 - (1) 1/2" diameter anchor w/ 2 1/4" EMB. into either LWC or NWC
 - (1) 1/2" diameter anchor w/ 3 1/4" EMB. into LWC
 - (1) 5/8" diameter anchor w/ 3 1/4" EMB. into LWC
- See Note 3.1 for conduit sizes upto 3.5" Diameter; See Note 3.2 for conduit sizes larger than 3.5" Diameter.
 - For conduit sizes up to 3.5" Diameter as tabulated above, all types of connections show in Section 7 are acceptable to be used with the following exceptions:
 - 3" Diameter Conduit:
 - (1) 3/8" diameter anchor w/ 2" EMB. into LWC
 - (1) 1/2" diameter anchor w/ 2 1/4" EMB. into LWC
 - 3.5" Diameter Conduit:
 - (1) 3/8" diameter anchor w/ 2" EMB. into either LWC or NWC
 - (1) 1/2" diameter anchor w/ 2 1/4" EMB. into LWC
 - (1) 5/8" diameter anchor w/ 3 1/4" EMB. into LWC
 - For pipe sizes larger than 3.5" Diameter as tabulated above, only the following connection types are acceptable:
 - 4" and 5" Diameter Conduit:
 - (1) 5/8" diameter anchor w/ 4 1/4" EMB. into LWC
 - (2) 1/2" diameter anchors with 3 1/4" EMB. into LWC
 - (1) 1/2" diameter bolts w/ 3 1/4" EMB., (1) 5/8" diameter anchor bolt with 3 1/4" or 4 1/4" EMB. into NWC.
 - All (2) anchor bolt connections into NWC.
 - Wood connection Detail 7d.2-1
 - 6" Diameter Conduit:
 - (1) 5/8" diameter anchor w/ 4 1/4" EMB. into LWC
 - (2) 1/2" diameter anchors with 3 1/4" EMB. into LWC
 - (1) 1/2" diameter bolts w/ 3 1/4" EMB., (1) 5/8" diameter anchor bolt with 3 1/4" or 4 1/4" EMB. into NWC.
 - (2) 1/2" diameter anchor bolts into NWC.
 - Wood connection Detail 7d.2-1
- These tables are based on a maximum S_{Ds} of 1.78g. Any S_{Ds} above 1.78g requires an RDP or SEOR review.



16100 S. Lathrop Ave
Harvey, IL 60426
Toll-Free: (800) 882-5543

www.unistrutseismic.com

Structural Engineer: Rami Elhassan
California SE No. 3930

Page:

2e.1

Pre-Designed Solutions (Conduit - RMC & IMC)

CONDUIT - RMC & IMC

MAX LATERAL FORCE $F_p = 0.40W_p$ (ASD)

MAX VERTICAL FORCE $E_v = 0.25W_p$ (ASD)

MAXIMUM BRACE ANGLE = 60° FROM HORIZONTAL

$a_p = 2.5$ $R_p = 6$

Diameter (in.)	Max Weight	Max Brace Spacing (ft.)	Max Vertical Support Spacing (ft.)	Gravity Weight (lbs.)	E_p (ASD) (lbs.)	W_p (lbs.)	F_p (ASD) (lbs.)	H Max (ft.)	Max Brace Length (ft.)	Min Brace Size	Min Vertical Rod Diameter Size	Max Rod Stiffener Spacing "L" (in.)	Pipe Clamp	Fitting	Brace Connection to Structure	Vertical Rod Connection to Structure
1/2	1.04 plf	17	10	10.40	2.60	17.68	7.07	9.06	10	P1000	3/8"	30	P1111	See Note 1	See Note 2	See Note 3
3/4	1.50 plf	19	10	15.00	3.75	28.50	11.40	9.06	10	P1000	3/8"	30	P1112			
1	2.27 plf	21	10	22.70	5.68	47.67	19.07	9.06	10	P1000	3/8"	30	P1113			
1 1/4	3.50 plf	23	10	35.00	8.75	80.50	32.20	9.06	10	P1000	3/8"	30	P1114			
1 1/2	4.40 plf	24	10	44.00	11.00	105.60	42.24	9.06	10	P1000	3/8"	30	P1115			
2	7.02 plf	27	10	70.20	17.55	189.54	75.82	9.06	10	P1000	3/8"	21	P1117			
2 1/2	9.97 plf	30	10	99.70	24.93	299.10	119.64	9.06	10	P1000	3/8"	18	P1118			
3	14.15 plf	32	10	141.50	35.38	452.80	181.12	9.06	10	P1000	3/8"	12	P1119			
3 1/2	17.10 plf	34	10	171.00	42.75	581.40	232.56	9.06	10	P1000	3/8"	12	P1120			
4	20.91 plf	36	10	209.10	52.28	752.76	301.10	9.06	10	P1000	1/2"	21	P1121			
5	29.99 plf	25	10	299.90	74.98	749.75	299.90	9.06	10	P1000	1/2"	21	P1123			
6	42.61 plf	20	10	426.10	106.53	852.20	340.88	9.06	10	P1000	1/2"	18	P1124			

Notes:

1. All fittings shown in Section 5 are acceptable to be used with the conduit diameters in the table above, except SPF200 for 6" diameter conduit.
2. All types of connections show in Section 7 are acceptable to be used with the conduit diameters in the table above with the following exceptions:
 - a. 2.5" Diameter Conduit:
 - i. (1) 1/2" diameter anchor w/ 2 1/4" EMB. into LWC
 - b. 3" Diameter Conduit:
 - i. (1) 1/2" diameter anchor w/ 2 1/4" EMB. into LWC
 - ii. (1) 5/8" diameter anchor w/ 3 1/4" EMB. into LWC
 - c. 3.5" Diameter Conduit:
 - i. (1) 1/2" diameter anchor w/ 2 1/4" EMB. into either LWC or NWC
 - ii. (1) 1/2" diameter anchor w/ 3 1/4" EMB. into LWC
 - iii. (1) 5/8" diameter anchor w/ 3 1/4" EMB. into LWC
 - d. 4", 5" and 6" Diameter Conduits:
 - i. (1) 1/2" diameter anchor w/ 2 1/4" EMB. into either LWC or NWC
 - ii. (1) 1/2" diameter anchor w/ 3 1/4" EMB. into LWC
 - iii. (1) 5/8" diameter anchor w/ 3 1/4" EMB. into LWC
 - iv. (2) 3/8" diameter anchor w/ 2" EMB. into LWC
 - v. (2) 1/2" diameter anchor w/ 2 1/4" EMB. into LWC
3. See Note 3.1 for conduit sizes up to 3.5" Diameter; See Note 3.2 for conduit sizes larger than 3.5" Diameter.
 - 3.1. For conduit sizes up to 3.5" Diameter as tabulated above, all types connections show in Section 7 are acceptable to be used with the following exceptions:
 - a. 2.5" Diameter Conduit:
 - i. (1) 3/8" diameter anchor w/ 2" EMB. into LWC
 - ii. (1) 1/2" diameter anchor w/ 2 1/4" EMB. into LWC
 - b. 3" Diameter Conduit:
 - i. (1) 3/8" diameter anchor w/ 2" EMB. into either LWC or NWC
 - ii. (1) 1/2" diameter anchor w/ 2 1/4" EMB. into LWC
 - iii. (1) 5/8" diameter anchor w/ 3 1/4" EMB. into LWC
 - c. 3.5" Diameter Conduit:
 - i. (1) 3/8" diameter anchor w/ 2" EMB. into either LWC or NWC
 - ii. (1) 1/2" diameter anchor w/ 2 1/4" EMB. into either LWC or NWC.
 - iii. (1) 1/2" diameter anchor w/ 3 1/4" EMB. into LWC.
 - iv. (1) 5/8" diameter anchor w/ 3 1/4" EMB. into LWC
 - v. (2) 3/8" diameter anchor w/ 2" EMB. into LWC
 - vi. (2) 1/2" diameter anchor w/ 2 1/4" EMB. into LWC
 - vii. Wood Connection Detail 7d.2-1
 - 3.2. For conduit sizes larger than 3.5" Diameter as tabulated above, only the following connection types are acceptable:
 - a. 4" and 5" Diameter Conduit:
 - i. (1) 5/8" diameter anchor w/ 4 1/4" EMB. into LWC
 - ii. (2) 1/2" diameter anchors with 3 1/4" EMB. into LWC
 - iii. (1) 1/2" diameter bolts w/ 3 1/4" EMB., (1) 5/8" diameter anchor bolt with 3 1/4" or 4 1/4" EMB. into NWC.
 - iv. All (2) anchor bolt connections into NWC.
 - v. Wood connection Detail 7d.2-1
 - b. 6" Diameter Conduit:
 - i. (1) 5/8" diameter anchor bolt with 4 1/4" EMB. into NWC.
 - ii. (2) 1/2" diameter anchor bolt w/ 3 1/4" EMB. into NWC.
4. These tables are based on a maximum S_{Ds} of 1.78g. Any S_{Ds} above 1.78g requires an RDP or SEOR review.



16100 S. Lathrop Ave
Harvey, IL 60426
Toll-Free: (800) 882-5543

www.unistrutseismic.com

Structural Engineer: Rami Elhassan
California SE No. 3930

Page:

2e.2

Pre-Designed Solutions (Conduit - RMC & IMC)

CONDUIT - RMC & IMC

MAX LATERAL FORCE $F_p = 0.55W_p$ (ASD)

MAX VERTICAL FORCE $E_v = 0.25W_p$ (ASD)

MAXIMUM BRACE ANGLE = 60° FROM HORIZONTAL

$\alpha_p = 2.5$ $R_p = 6$

							I	II	III	IV	V	VI	VII	VIII	IX	X
Diameter (in.)	Max Weight	Max Brace Spacing (ft.)	Max Vertical Support Spacing (ft.)	Gravity Weight (lbs.)	E_p (ASD) (lbs.)	W_p (lbs.)	F_p (ASD) (lbs.)	H Max (ft.)	Max Brace Length (ft.)	Min Brace Size	Min Vertical Rod Diameter Size	Max Rod Stiffener Spacing "L" (in.)	Pipe Clamp	Fitting	Brace Connection to Structure	Vertical Rod Connection to Structure
½	1.04 plf	15	10	10.40	2.60	15.60	8.58	9.06	10	P1000	¾"	30	P1111	See Note 1	See Note 2	See Note 3
¾	1.50 plf	17	10	15.00	3.75	25.50	14.03	9.06	10	P1000	¾"	30	P1112			
1	2.27 plf	19	10	22.70	5.68	43.13	23.72	9.06	10	P1000	¾"	30	P1113			
1¼	3.50 plf	21	10	35.00	8.75	73.50	40.43	9.06	10	P1000	¾"	30	P1114			
1½	4.40 plf	22	10	44.00	11.00	96.80	53.24	9.06	10	P1000	¾"	27	P1115			
2	7.02 plf	25	10	70.20	17.55	175.50	96.53	9.06	10	P1000	¾"	18	P1117			
2½	9.97 plf	28	10	99.70	24.93	279.16	153.54	9.06	10	P1000	¾"	15	P1118			
3	14.15 plf	30	10	141.50	35.38	424.50	233.48	9.06	10	P1000	¾"	12	P1119			
3½	17.10 plf	31	10	171.00	42.75	530.10	291.56	9.06	10	P1000	½"	21	P1120			
4	20.91 plf	30	10	209.10	52.28	627.30	345.02	9.06	10	P1000	½"	18	P1121			
5	29.99 plf	20	10	299.90	74.98	599.80	329.89	9.06	10	P1000	½"	18	P1123			
6	42.61 plf	15	10	426.10	106.53	639.15	351.53	9.06	10	P1000	½"	18	P1124			

Notes:

1. All fittings shown in Section 5 are acceptable to be used with the conduit diameters in the table above, except SPF200 for 4" diameter conduit.
 - a. 2.5" Diameter Conduit:
 - i. (1) 3/8" diameter anchor w/ 2" EMB. into LWC
 - ii. (1) 1/2" diameter anchor w/ 2 1/4" EMB. into LWC
 - b. 3" and 3.5" Diameter Conduits:
 - i. (1) 3/8" diameter anchor w/ 2" EMB. into either LWC or NWC
 - ii. (1) 1/2" diameter anchor w/ 2 1/4" EMB. into either LWC or NWC.
 - iii. (1) 1/2" diameter anchor w/ 3 1/4" EMB. into LWC.
 - iv. (1) 5/8" diameter anchor w/ 3 1/4" EMB. into LWC
 - v. (2) 3/8" diameter anchor w/ 2" EMB. into LWC
 - vi. (2) 1/2" diameter anchor w/ 2 1/4" EMB. into LWC
 - vii. Wood Connection Detail 7d.2-1
 - c. 3.5" Diameter Conduit:
 - i. (1) 1/2" diameter anchor w/ 2 1/4" EMB. into either LWC or NWC
 - ii. (1) 1/2" diameter anchor w/ 3 1/4" EMB. into LWC
 - iii. (1) 5/8" diameter anchor w/ 3 1/4" EMB. into LWC
 - d. 4", 5" and 6" Diameter Conduits:
 - i. (1) 1/2" diameter anchor w/ 2 1/4" EMB. into either LWC or NWC
 - ii. (1) 1/2" diameter anchor w/ 3 1/4" EMB. into LWC
 - iii. (1) 5/8" diameter anchor w/ 3 1/4" EMB. into LWC
 - iv. (2) 3/8" diameter anchor w/ 2" EMB. into LWC
 - v. (2) 1/2" diameter anchor w/ 2 1/4" EMB. into LWC
2. All types of connections shown in Section 7 are acceptable to be used with the conduit diameters in the table above with the following exceptions:
 - a. 4" and 5" Diameter Conduit:
 - i. (1) 5/8" diameter anchor w/ 4 1/4" EMB. into LWC
 - ii. (1) 1/2" diameter bolts w/ 3 1/4" EMB., (1) 5/8" diameter anchor bolt with 3 1/4" or 4 1/4" EMB. into NWC.
 - iii. (2) 1/2" diameter anchor bolt w/ 3 1/4" EMB. into NWC.
 - b. 6" Diameter Conduit:
 - i. (1) 5/8" diameter anchor bolt with 4 1/4" EMB. into NWC.
 - ii. (2) 1/2" diameter anchor bolt w/ 3 1/4" EMB. into NWC.
3. See Note 3.1 for conduit sizes up to 3.5" Diameter; See Note 3.2 for conduit sizes larger than 3.5" Diameter.
 - 3.1. For conduit sizes up to 3.5" Diameter as tabulated above, all types of connections show in Section 7 are acceptable to be used with the following exceptions:
- 3.2. For conduit sizes larger than 3.5" Diameter as tabulated above, only the following connection types are acceptable:
4. These tables are based on a maximum S_{DS} of 1.78g. Any S_{DS} above 1.78g requires an RDP or SEOR review.



16100 S. Lathrop Ave
Harvey, IL 60426
Toll-Free: (800) 882-5543

www.unistrutseismic.com

Structural Engineer: Rami Elhassan
California SE No. 3930

Page:

2e.3

Pre-Designed Solutions (Conduit - EMT)

CONDUIT - EMT

MAX LATERAL FORCE $F_p = 0.25W_p$ (ASD)

MAX VERTICAL FORCE $E_v = 0.25W_p$ (ASD)

MAXIMUM BRACE ANGLE = 60° FROM HORIZONTAL

$a_p = 2.5$ $R_p = 6$

							I	II	III	IV	V	VI	VII	VIII	IX	X
Diameter (in.)	Max Weight	Max Brace Spacing (ft.)	Max Vertical Support Spacing (ft.)	Gravity Weight (lbs.)	E_p (ASD) (lbs.)	W_p (lbs.)	F_p (ASD) (lbs.)	H Max (ft.)	Max Brace Length (ft.)	Min Brace Size	Min Vertical Rod Diameter Size	Max Rod Stiffener Spacing "L" (in.)	Pipe Clamp	Fitting	Brace Connection to Structure	Vertical Rod Connection to Structure
½	0.52 plf	10	10	5.20	1.30	5.20	1.30	9.06	10	P1000	¾"	30	P1426	See Note 1	See Note 2	See Note 3
¾	0.87 plf	10	10	8.70	2.18	8.70	2.18	9.06	10	P1000	¾"	30	P1427			
1	1.33 plf	10	10	13.30	3.33	13.30	3.33	9.06	10	P1000	¾"	30	P1428			
1¼	2.18 plf	10	10	21.80	5.45	21.80	5.45	9.06	10	P1000	¾"	30	P1429			
1½	2.76 plf	10	10	27.60	6.90	27.60	6.90	9.06	10	P1000	¾"	30	P1430			
2	4.10 plf	10	10	41.00	10.25	41.00	10.25	9.06	10	P1000	¾"	30	P1431			
2½	5.90 plf	10	10	59.00	14.75	59.00	14.75	9.06	10	P1000	¾"	30	P1118			
3	8.39 plf	10	10	83.90	20.98	83.90	20.98	9.06	10	P1000	¾"	30	P1119			
3½	11.22 plf	10	10	112.20	28.05	112.20	28.05	9.06	10	P1000	¾"	30	P1120			
4	13.87 plf	10	10	138.70	34.68	138.70	34.68	9.06	10	P1000	¾"	30	P1121			

Notes:

1. All fittings shown in Section 5 are acceptable to be used with the conduit diameters in the table above.
2. All types of connections shown in Section 7 are acceptable to be used with the conduit diameters in the table above.
3. All types of connections shown in Section 7 are acceptable to be used with the conduit diameters in the table above.
4. These tables are based on a maximum S_{Ds} of 1.78g. Any S_{Ds} above 1.78g requires an RDP or SEOR review.

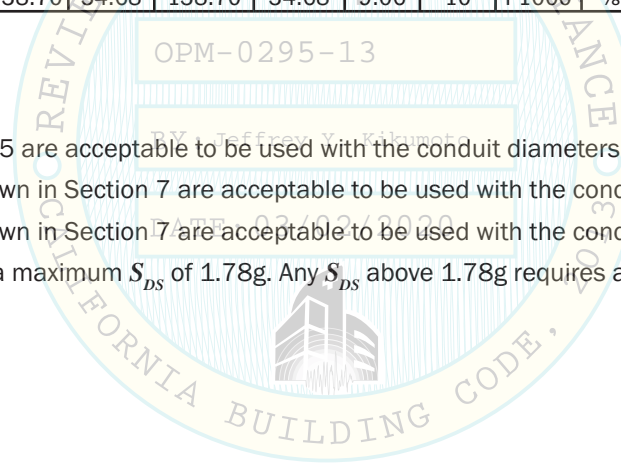

16100 S. Lathrop Ave
Harvey, IL 60426
Toll-Free: (800) 882-5543

www.unistrutseismic.com

Structural Engineer: Rami Elhassan
California SE No. 3930

Page:

2f.1

Pre-Designed Solutions (Conduit - EMT)

CONDUIT - EMT

MAX LATERAL FORCE $F_p = 0.40W_p$ (ASD)

MAX VERTICAL FORCE $E_v = 0.25W_p$ (ASD)

MAXIMUM BRACE ANGLE = 60° FROM HORIZONTAL

$a_p = 2.5$ $R_p = 6$

													I	II	III	IV	V	VI	VII	VIII	IX	X
Diameter (in.)	Max Weight	Max Brace Spacing (ft.)	Max Vertical Support Spacing (ft.)	Gravity Weight (lbs.)	E_p (ASD) (lbs.)	W_p (lbs.)	F_p (ASD) (lbs.)	H Max (ft.)	Max Brace Length (ft.)	Min Brace Size	Min Vertical Rod Diameter Size	Max Rod Stiffener Spacing "L" (in.)	Pipe Clamp	Fitting	Brace Connection to Structure	Vertical Rod Connection to Structure						
½	0.52 plf	10	10	5.20	1.30	5.20	2.08	9.06	10	P1000	¾"	30	P1426	See Note 1	See Note 2	See Note 3						
¾	0.87 plf	10	10	8.70	2.18	8.70	3.48	9.06	10	P1000	¾"	30	P1427									
1	1.33 plf	10	10	13.30	3.33	13.30	5.32	9.06	10	P1000	¾"	30	P1428									
1¼	2.18 plf	10	10	21.80	5.45	21.80	8.72	9.06	10	P1000	¾"	30	P1429									
1½	2.76 plf	10	10	27.60	6.90	27.60	11.04	9.06	10	P1000	¾"	30	P1430									
2	4.10 plf	10	10	41.00	10.25	41.00	16.40	9.06	10	P1000	¾"	30	P1431									
2½	5.90 plf	10	10	59.00	14.75	59.00	23.60	9.06	10	P1000	¾"	30	P1118									
3	8.39 plf	10	10	83.90	20.98	83.90	33.56	9.06	10	P1000	¾"	30	P1119									
3½	11.22 plf	10	10	112.20	28.05	112.20	44.88	9.06	10	P1000	¾"	27	P1120									
4	13.87 plf	10	10	138.70	34.68	138.70	55.48	9.06	10	P1000	¾"	24	P1121									

Notes:

1. All fittings shown in Section 5 are acceptable to be used with the conduit diameters in the table above.
2. All types of connections show in Section 7 are acceptable to be used with the conduit diameters in the table above.
3. All types of connections show in Section 7 are acceptable to be used with the conduit diameters in the table above.
4. These tables are based on a maximum S_{Ds} of 1.78g. Any S_{Ds} above 1.78g requires an RDP or SEOR review.

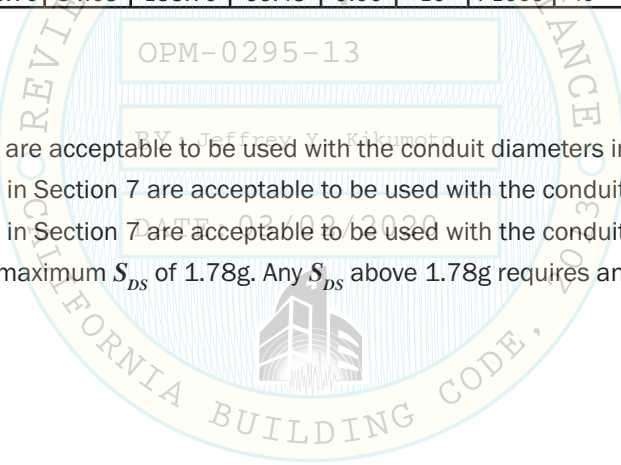

16100 S. Lathrop Ave
Harvey, IL 60426
Toll-Free: (800) 882-5543

www.unistrutseismic.com

Structural Engineer: Rami Elhassan
California SE No. 3930

Page:

2f.2

Pre-Designed Solutions (Conduit - EMT)

CONDUIT - EMT

MAX LATERAL FORCE $F_p = 0.55 W_p$ (ASD)

MAX VERTICAL FORCE $E_v = 0.25 W_p$ (ASD)

MAXIMUM BRACE ANGLE = 60° FROM HORIZONTAL

$a_p = 2.5$ $R_p = 6$

														I	II	III	IV	V	VI	VII	VIII	IX	X
Diameter (in.)	Max Weight	Max Brace Spacing (ft.)	Max Vertical Support Spacing (ft.)	Gravity Weight (lbs.)	E_p (ASD) (lbs.)	W_p (lbs.)	F_p (ASD) (lbs.)	H Max (ft.)	Max Brace Length (ft.)	Min Brace Size	Min Vertical Rod Diameter Size	Max Rod Stiffener Spacing "L" (in.)	Pipe Clamp	Fitting	Brace Connection to Structure	Vertical Rod Connection to Structure							
½	0.52 plf	10	10	5.20	1.30	5.20	2.86	9.06	10	P1000	¾"	30	P1426	See Note 1	See Note 2	See Note 3							
¾	0.87 plf	10	10	8.70	2.18	8.70	4.79	9.06	10	P1000	¾"	30	P1427										
1	1.33 plf	10	10	13.30	3.33	13.30	7.32	9.06	10	P1000	¾"	30	P1428										
1¼	2.18 plf	10	10	21.80	5.45	21.80	11.99	9.06	10	P1000	¾"	30	P1429										
1½	2.76 plf	10	10	27.60	6.90	27.60	15.18	9.06	10	P1000	¾"	30	P1430										
2	4.10 plf	10	10	41.00	10.25	41.00	22.55	9.06	10	P1000	¾"	30	P1431										
2½	5.90 plf	10	10	59.00	14.75	59.00	32.45	9.06	10	P1000	¾"	30	P1118										
3	8.39 plf	10	10	83.90	20.98	83.90	46.15	9.06	10	P1000	¾"	27	P1119										
3½	11.22 plf	10	10	112.20	28.05	112.20	61.71	9.06	10	P1000	¾"	24	P1120										
4	13.87 plf	10	10	138.70	34.68	138.70	76.29	9.06	10	P1000	¾"	21	P1121										

Notes:

1. All fittings shown in Section 5 are acceptable to be used with the conduit diameters in the table above.
2. All types of connections shown in Section 7 are acceptable to be used with the conduit diameters in the table above.
3. All types of connections show in Section 7 are acceptable to be used with the conduit diameters in the table above, with the following exceptions:
 - a. 4" Diameter Conduit:
 - i. (1) 3/8" diameter anchor w/ 2" EMB. into LWC.
 - ii. (1) 1/2" diameter anchor w/ 2 1/4" EMB. into LWC.
4. These tables are based on a maximum S_{DS} of 1.78g. Any S_{DS} above 1.78g requires an RDP or SEOR review.

Atkore
Unistrut

16100 S. Lathrop Ave
Harvey, IL 60426
Toll-Free: (800) 882-5543

www.unistrutseismic.com



Structural Engineer: Rami Elhassan
California SE No. 3930

Page:

2f.3

Pre-Designed Solutions (Copper Pipe & Tube - Type K & L)

COPPER PIPE & TUBE (TYPE K & L) - WATER FILLED WITH INSULATION, DRAWN WITH SOLDERED JOINTS

MAX LATERAL FORCE $F_p = 0.25W_p$ (ASD)

MAX VERTICAL FORCE $E_v = 0.25W_p$ (ASD)

MAXIMUM BRACE ANGLE = 60° FROM HORIZONTAL

$a_p = 2.5$ $R_p = 6$

							I	II	III	IV	V	VI	VII	VIII	IX	X
Diameter (in.)	Max Weight	Max Brace Spacing (ft.)	Max Vertical Support Spacing (ft.)	Gravity Weight (lbs.)	E_p (ASD) (lbs.)	W_p (lbs.)	F_p (ASD) (lbs.)	H Max (ft.)	Max Brace Length (ft.)	Min Brace Size	Min Vertical Rod Diameter Size	Max Rod Stiffener Spacing "L" (in.)	Pipe Clamp ⁴	Fitting	Brace Connection to Structure	Vertical Rod Connection to Structure
3/8	0.62 plf	10	5	3.12	0.78	6.24	1.56	9.06	10	P1000	3/8"	30	P2027	See Note 1	See Note 2	See Note 3
1/2	0.84 plf	12	5	4.19	1.05	10.06	2.51	9.06	10	P1000	3/8"	30	P2028			
5/8	1.06 plf	13	5	5.31	1.33	13.81	3.45	9.06	10	P1000	3/8"	30	P2029			
3/4	1.43 plf	14	5	7.15	1.79	20.01	5.00	9.06	10	P1000	3/8"	30	P2030			
1	1.88 plf	16	6	11.28	2.82	30.08	7.52	9.06	10	P1000	3/8"	30	P2032			
1 1/4	2.37 plf	18	7	16.59	4.15	42.66	10.67	9.06	10	P1000	3/8"	30	P2034			
1 1/2	3.00 plf	20	8	24.00	6.00	60.00	15.00	9.06	10	P1000	3/8"	30	P1430			
2	4.36 plf	24	8	34.88	8.72	104.64	26.16	9.06	10	P1000	3/8"	30	P2040			
2 1/2	6.14 plf	26	9	55.26	13.82	159.64	39.91	9.06	10	P1000	3/8"	30	P2044			
3	8.17 plf	29	10	81.70	20.43	236.93	59.23	9.06	10	P1000	3/8"	24	P2048			
3 1/2	10.51 plf	31	10	105.10	26.28	325.81	81.45	9.06	10	P1000	3/8"	21	P2052			
4	13.36 plf	33	10	133.60	33.40	440.88	110.22	9.06	10	P1000	3/8"	18	P2056			

Notes:

1. All fittings shown in Section 5 are acceptable to be used with the pipe diameters in the table above,
2. All types of connections show in Section 7 are acceptable to be used with the pipe diameters in the table above.
3. All types of connections show in Section 7 are acceptable to be used with the pipe diameters in the table above with the following exceptions:
 - a. 4" Diameter Copper Pipe -L or K Type:
 - i. At the hanger attachment to structure, where a seismic brace is connected to the hanger, (1) 3/8" diameter anchor w/ 2" EMB. into LWC is NOT acceptable.
 - ii. At the hanger attachment to structure, where a seismic brace is connected to the hanger, (1) 1/2" diameter anchor w/ 2 1/4" EMB. into LWC is NOT acceptable.
4. Pipe clamps require the use of the P2600 Unicushion per Page 5d.3.
5. These tables are based on a maximum S_{DS} of 1.78g. Any S_{DS} above 1.78g requires an RDP or SEOR review.

<p style="text-align: center;">16100 S. Lathrop Ave Harvey, IL 60426 Toll-Free: (800) 882-5543</p> <p style="text-align: center;">www.unistrutseismic.com</p>	<p>Structural Engineer: Rami Elhassan California SE No. 3930</p>	<p>Page:</p> <h1 style="text-align: center;">2g.1</h1>
	<p>www.unistrutseismic.com</p>	

Pre-Designed Solutions (Copper Pipe & Tube - Type K & L)

COPPER PIPE & TUBE (TYPE K & L) - WATER FILLED WITH INSULATION, DRAWN WITH SOLDERED JOINTS

MAX LATERAL FORCE $F_p = 0.40W_p$ (ASD)

MAX VERTICAL FORCE $E_v = 0.25W_p$ (ASD)

MAXIMUM BRACE ANGLE = 60° FROM HORIZONTAL

$a_p = 2.5$ $R_p = 6$

							I	II	III	IV	V	VI	VII	VIII	IX	X
Diameter (in.)	Max Weight	Max Brace Spacing (ft.)	Max Vertical Support Spacing (ft.)	Gravity Weight (lbs.)	F_p (ASD) (lbs.)	W_p (lbs.)	F_p (ASD) (lbs.)	H Max (ft.)	Max Brace Length (ft.)	Min Brace Size	Min Vertical Rod Diameter Size	Max Rod Stiffener Spacing "L" (in.)	Pipe Clamp ⁴	Fitting	Brace Connection to Structure	Vertical Rod Connection to Structure
3/8	0.62 plf	9	5	3.12	0.78	5.62	2.25	9.06	10	P1000	3/8"	30	P2027	See Note 1	See Note 2	See Note 3
1/2	0.84 plf	10	5	4.19	1.05	8.38	3.35	9.06	10	P1000	3/8"	30	P2028			
5/8	1.06 plf	11	5	5.31	1.33	11.68	4.67	9.06	10	P1000	3/8"	30	P2029			
3/4	1.43 plf	13	5	7.15	1.79	18.58	7.43	9.06	10	P1000	3/8"	30	P2030			
1	1.88 plf	15	6	11.28	2.82	28.20	11.28	9.06	10	P1000	3/8"	30	P2032			
1 1/4	2.37 plf	16	7	16.59	4.15	37.92	15.17	9.06	10	P1000	3/8"	30	P2034			
1 1/2	3.00 plf	18	8	24.00	6.00	54.00	21.60	9.06	10	P1000	3/8"	30	P1430			
2	4.36 plf	21	8	34.88	8.72	91.56	36.62	9.06	10	P1000	3/8"	30	P2040			
2 1/2	6.14 plf	23	9	55.26	13.82	141.22	56.49	9.06	10	P1000	3/8"	24	P2044			
3	8.17 plf	26	10	81.70	20.43	212.42	84.97	9.06	10	P1000	3/8"	21	P2048			
3 1/2	10.51 plf	28	10	105.10	26.28	294.28	117.71	9.06	10	P1000	3/8"	18	P2052			
4	13.36 plf	29	10	133.60	33.40	387.44	154.98	9.06	10	P1000	3/8"	15	P2056			

Notes:

1. All fittings shown in Section 5 are acceptable to be used with the pipe diameters in the table above
2. All types of connections shown in Section 7 are acceptable to be used with the pipe diameters in the table above with the following exceptions:
 - a. 4" Diameter Copper Pipe -L or K Type:
 - i. At the brace attachment to structure, (1) 1/2" diameter anchor w/ 2 1/4" EMB. into LWC is NOT acceptable.
 - b. 3.5" Diameter Copper Pipe -L or K Type:
 - i. At the brace attachment to structure, (1) 1/2" diameter anchor w/ 2 1/4" EMB. into LWC is NOT acceptable
3. All types of connections show in Section 7 are acceptable to be used with the pipe diameters in the table above with the following exceptions:
 - a. 4" Diameter Copper Pipe -L or K Type:
 - i. At the hanger attachment to structure, where a seismic brace is connected to the hanger, (1) 3/8" diameter anchor w/ 2" EMB. into LWC is NOT acceptable.
 - ii. At the hanger attachment to structure, where a seismic brace is connected to the hanger, (1) 1/2" diameter anchor w/ 2 1/4" EMB. into LWC is NOT acceptable.
 - iii. At the hanger attachment to structure, where a seismic brace is connected to the hanger, (1) 5/8" diameter anchor w/ 3 1/4" EMB. into LWC is NOT acceptable.
 - b. 3.5" Diameter Copper Pipe -L or K Type:
 - i. At the hanger attachment to structure, where a seismic brace is connected to the hanger, (1) 3/8" diameter anchor w/ 2" EMB. into LWC is NOT acceptable.
 - ii. At the hanger attachment to structure, where a seismic brace is connected to the hanger, (1) 1/2" diameter anchor w/ 2 1/4" EMB. into LWC is NOT acceptable.
4. Pipe clamps require the use of the P2600 Unicushion per Page 5d.3.
5. These tables are based on a maximum S_{DS} of 1.78g. Any S_{DS} above 1.78g requires an RDP or SEOR review.



16100 S. Lathrop Ave
Harvey, IL 60426
Toll-Free: (800) 882-5543

www.unistrutseismic.com

Structural Engineer: Rami Elhassan
California SE No. 3930

Page:

2g.2

Pre-Designed Solutions (Copper Pipe & Tube - Type K & L)

COPPER PIPE & TUBE (TYPE K & L) - WATER FILLED WITH INSULATION, DRAWN WITH SOLDERED JOINTS

MAX LATERAL FORCE $F_p = 0.55W_p$ (ASD)

MAX VERTICAL FORCE $E_v = 0.25W_p$ (ASD)

MAXIMUM BRACE ANGLE = 60° FROM HORIZONTAL

$a_p = 2.5$ $R_p = 6$

							I	II	III	IV	V	VI	VII	VIII	IX	X
Diameter (in.)	Max Weight	Max Brace Spacing (ft.)	Max Vertical Support Spacing (ft.)	Gravity Weight (lbs.)	F_p (ASD) (lbs.)	W_p (lbs.)	F_p (ASD) (lbs.)	H Max (ft.)	Max Brace Length (ft.)	Min Brace Size	Min Vertical Rod Diameter Size	Max Rod Stiffener Spacing "L" (in.)	Pipe Clamp ⁴	Fitting	Brace Connection to Structure	Vertical Rod Connection to Structure
3/8	0.62 plf	8	5	3.12	0.78	4.99	2.75	9.06	10	P1000	3/8"	30	P2027	See Note 1	See Note 2	See Note 3
1/2	0.84 plf	10	5	4.19	1.05	8.38	4.61	9.06	10	P1000	3/8"	30	P2028			
5/8	1.06 plf	11	5	5.31	1.33	11.68	6.43	9.06	10	P1000	3/8"	30	P2029			
3/4	1.43 plf	12	5	7.15	1.79	17.15	9.43	9.06	10	P1000	3/8"	30	P2030			
1	1.88 plf	13	6	11.28	2.82	24.44	13.44	9.06	10	P1000	3/8"	30	P2032			
1 1/4	2.37 plf	15	7	16.59	4.15	35.55	19.55	9.06	10	P1000	3/8"	30	P2034			
1 1/2	3.00 plf	16	8	24.00	6.00	48.00	26.40	9.06	10	P1000	3/8"	30	P1430			
2	4.36 plf	19	8	34.88	8.72	82.84	45.56	9.06	10	P1000	3/8"	27	P2040			
2 1/2	6.14 plf	21	9	55.26	13.82	128.94	70.92	9.06	10	P1000	3/8"	21	P2044			
3	8.17 plf	24	10	81.70	20.43	196.08	107.84	9.06	10	P1000	3/8"	18	P2048			
3 1/2	10.51 plf	25	10	105.10	26.28	262.75	144.51	9.06	10	P1000	3/8"	15	P2052			
4	13.36 plf	26	10	133.60	33.40	347.36	191.05	9.06	10	P1000	3/8"	12	P2056			

Notes:

1. All fittings shown in Section 5 are acceptable to be used with the pipe diameters in the table above
2. All types of connections shown in Section 7 are acceptable to be used with the pipe diameters in the table above with the following exceptions:
 - a. 4" Diameter Copper Pipe -L or K Type:
 - i. At the brace attachment to structure, (1) 1/2" diameter anchor w/ 2 1/4" EMB. into LWC is NOT acceptable.
 - ii. At the brace attachment to structure, (1) 5/8" diameter anchor w/ 3 1/4" EMB. into LWC is NOT acceptable.
 - b. 3.5" Diameter Copper Pipe -L or K Type:
 - i. At the brace attachment to structure, (1) 1/2" diameter anchor w/ 2 1/4" EMB. into LWC is NOT acceptable
3. All types of connections show in Section 7 are acceptable to be used with the pipe diameters in the table above with the following exceptions:
 - a. 4" Diameter Copper Pipe -L or K Type:
 - i. At the hanger attachment to structure, where a seismic brace is connected to the hanger, (1) 3/8" diameter anchor w/ 2" EMB. into LWC is NOT acceptable.
 - ii. At the hanger attachment to structure, where a seismic brace is connected to the hanger, (1) 1/2" diameter anchor w/ 2 1/4" EMB. into LWC is NOT acceptable.
 - iii. At the hanger attachment to structure, where a seismic brace is connected to the hanger, (1) 5/8" diameter anchor w/ 3 1/4" EMB. into LWC is NOT acceptable.
 - iv. At the hanger attachment to structure, where a seismic brace is connected to the hanger, (1) 3/8" diameter anchor w/ 2" EMB. into NWC is NOT acceptable.
 - b. 3.5" Diameter Copper Pipe -L or K Type:
 - i. At the hanger attachment to structure, where a seismic brace is connected to the hanger, (1) 3/8" diameter anchor w/ 2" EMB. into LWC is NOT acceptable.
 - ii. At the hanger attachment to structure, where a seismic brace is connected to the hanger, (1) 1/2" diameter anchor w/ 2 1/4" EMB. into LWC is NOT acceptable.
4. Pipe clamps require the use of the P2600 Unicushion per Page 5d.3.
5. These tables are based on a maximum S_{DS} of 1.78g. Any S_{DS} above 1.78g requires an RDP or SEOR review.



16100 S. Lathrop Ave
Harvey, IL 60426
Toll-Free: (800) 882-5543

www.unistrutseismic.com

Structural Engineer: Rami Elhassan
California SE No. 3930

Page:

2g.3

TRAPEZE SUPPORT TRANSVERSE RESTRAINT TYPE

See section 7 for structural attachments for hangers and brace

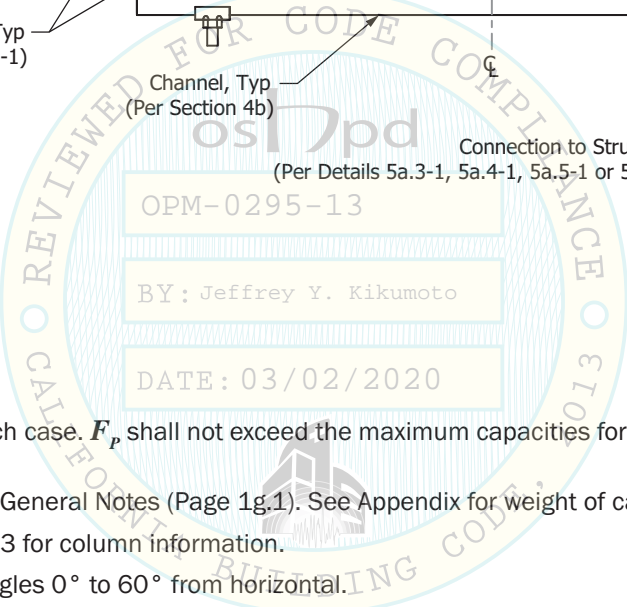
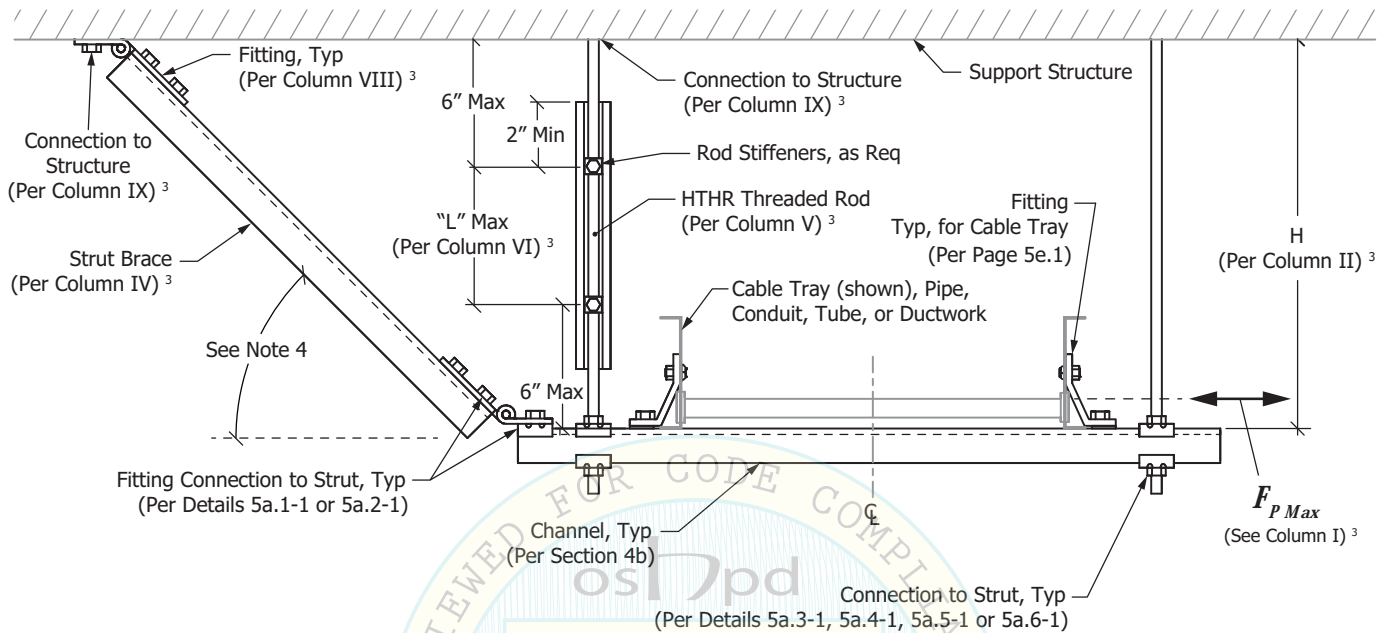

Notes:

- 1) F_p shall be calculated for each case. F_p shall not exceed the maximum capacities for any of the components used to support the system.
- 2) Maximum cable tray size per General Notes (Page 1g.1). See Appendix for weight of cable tray.
- 3) Refer to page 2i.1 through 2i.3 for column information.
- 4) Braces can be installed at angles 0° to 60° from horizontal.
- 5) Fittings and Hardware shown are for graphical representation only. Final configuration may use any fitting or hardware component included in this OPM provided it has sufficient capacity and is used for its correct intent.
- 6) Cable Tray shall be approved on a project specific basis, or preapproved by OSHPD. Spacing limits set by the manufacturer shall not be exceeded. Cable Tray brace spacing shall be approved or preapproved by OSHPD.

 <p>16100 S. Lathrop Ave Harvey, IL 60426 Toll-Free: (800) 882-5543</p> <p>www.unistrutseismic.com</p>		Page:
	Structural Engineer: Rami Elhassan California SE No. 3930	2h.1

TRAPEZE SUPPORT LONGITUDINAL RESTRAINT TYPE

See section 7 for structural attachments for hangers and brace

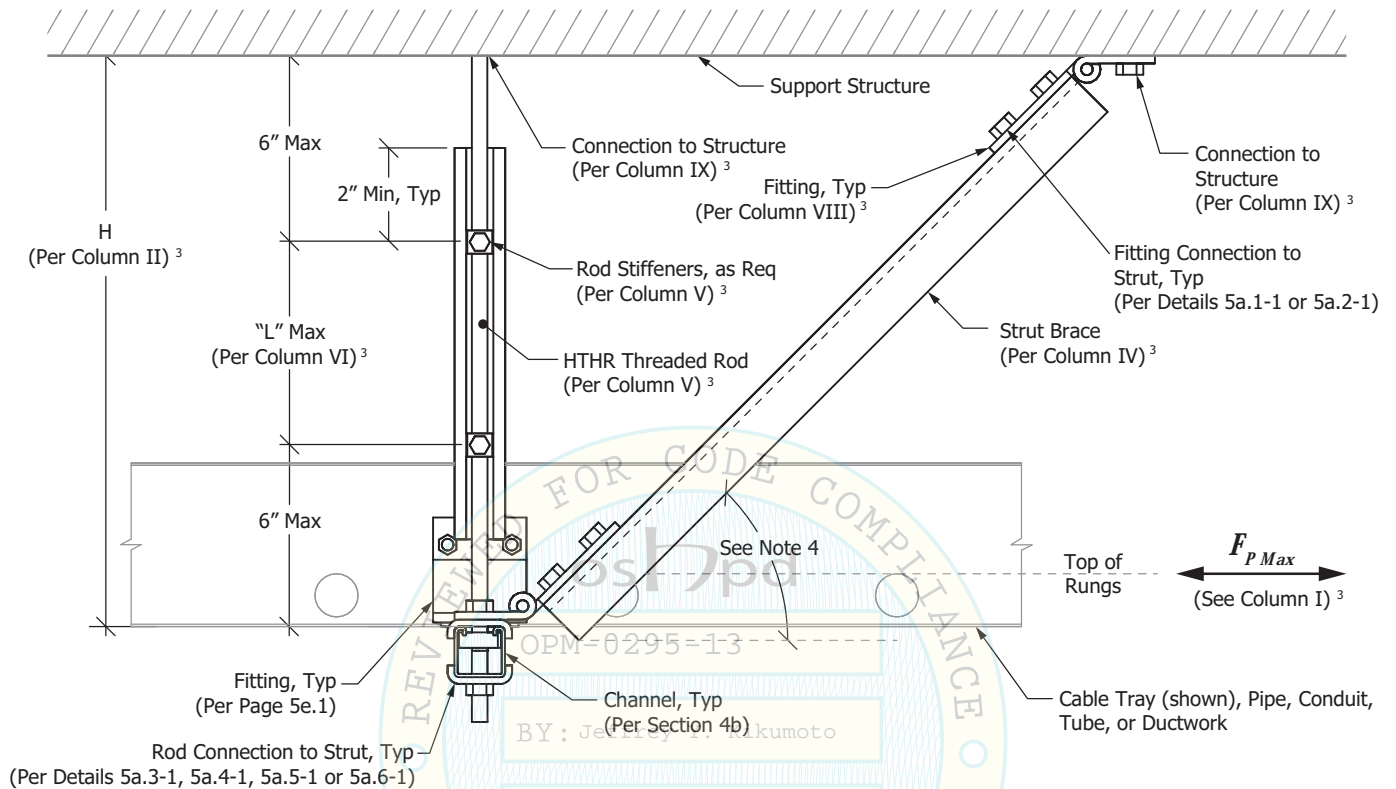

Notes:

- 1) F_p shall be calculated for each case. F_p shall not exceed the maximum capacities for any of the components used to support the system.
- 2) Maximum cable tray size per General Notes (Page 1g.1). See Appendix for weight of cable tray.
- 3) Refer to pages 2i.1 through 2i.3 for column information.
- 4) Braces can be installed at angles 0° to 60° from horizontal.
- 5) Fittings and Hardware shown are for graphical representation only. Final configuration may use any fitting or hardware component included in this OPM provided it has sufficient capacity and is used for its correct intent.
- 6) Cable Tray shall be approved on a project specific basis, or preapproved by OSHPD. Spacing limits set by the manufacturer shall not be exceeded. Cable Tray brace spacing shall be approved or preapproved by OSHPD.

Atkore
Unistrut

16100 S. Lathrop Ave
Harvey, IL 60426
Toll-Free: (800) 882-5543

www.unistrutseismic.com

Rami Elhassan
Structural Engineer: Rami Elhassan
California SE No. 3930

Page:

2h.2

Pre-Designed Solutions (Trapeze Supported Pipe, Conduit, Cable Tray & Ductwork)

TRAPEZE SUPPORTED COMPONENTS (MULTIPLE PIPES, MULTIPLE CONDUITS, CABLE TRAY & DUCTWORK)

MAX LATERAL FORCE $F_p = 0.25 W_p$ (ASD)

MAX VERTICAL FORCE $E_v = 0.25 W_p$ (ASD)

MAXIMUM BRACE ANGLE = 60° FROM HORIZONTAL

$a_p = 2.5$ $R_p = 6$

						I	II	III	IV	V	VI	VII	VIII	IX	X
Max Weight	Max Brace Spacing (ft.) ⁶	Max Vertical Support Spacing (ft.)	2/3 Gravity Weight (lbs.)	E_p (ASD) (lbs.)	W_p (lbs.)	F_p (ASD) (lbs.)	H Max (ft.)	Max Brace Length (ft.)	Min Brace Size	Min Vertical Rod Diameter Size	Max Rod Stiffener Spacing "L" (in.)	Trapeze Beam	Fitting	Brace Connection to Structure	Vertical Rod Connection to Structure
10.00 plf	20	10	66.67	16.67	200.00	50.00	9.06	10	P1000	3/8"	27	See Note 4	See Note 1	See Note 2	See Note 3
15.00 plf	20	10	100.00	25.00	300.00	75.00	9.06	10	P1000	3/8"	21				
30.00 plf	20	10	200.00	50.00	600.00	150.00	9.06	10	P1000	3/8"	15				
45.00 plf	20	10	300.00	75.00	900.00	225.00	9.06	10	P1000	3/8"	12				

Notes:

1. All fittings shown in Section 5 are acceptable to be used with trapeze restraints in the table above.
2. All types of connections shown in Section 7 are acceptable to be used with the trapeze restraints in the table above, except for the following connections:
 - a. Trapeze supporting 30 plf of weight:
 - i. (1) 1/2" diameter anchor w/ 2 1/4" EMB. into LWC
 - b. Trapeze supporting 45 plf of weight:
 - i. (1) 1/2" diameter anchor w/ 2 1/4" EMB. into either LWC or NWC
 - ii. (1) 1/2" diameter anchor w/ 3 1/4" EMB. into LWC
 - iii. (1) 5/8" diameter anchor w/ 3 1/4" EMB. into LWC
3. See Note 3.1 for trapeze supporting up to 15 plf weight; See Note 3.2 for trapeze supporting more than 15 plf.
 - 3.1. For trapeze supporting up to 15 plf as tabulated above, all types of connections shown in Section 7 are acceptable to be used.
 - 3.2 For trapeze supporting more than 15 plf as tabulated above, only the following connection types are acceptable:
 - i. (1) 5/8" diameter anchor w/ 4 1/4" EMB. into LWC
 - ii. (2) 1/2" diameter anchors w/ 3 1/4" EMB. into LWC
 - iii. (1) 1/2" diameter bolt w/ 3 1/4" EMB., (1) 5/8" diameter anchor bolt with 3 1/4" or 4 1/4" EMB. into NWC
 - iv. All (2) anchor bolt connections into NWC.
 - v. Wood connection Detail 7d.2-1.
4. Trapeze beam shall be sized based on actual span in accordance with 4b.0 through 4b.6.
5. These tables are based on a maximum S_{DS} of 1.78g. Any S_{DS} above 1.78g requires an RDP or SEOR review.
6. Cable Tray restraint spacing shall be approved on a project specific basis, or preapproved by OSHPD. Spacing limits set by the manufacturer shall not be exceeded.

<p style="font-size: small; margin-top: 10px;">16100 S. Lathrop Ave Harvey, IL 60426 Toll-Free: (800) 882-5543</p> <p style="font-size: x-small; margin-top: 5px;">www.unistrutseismic.com</p>	<p style="font-weight: bold; margin-top: 5px;">Structural Engineer: Rami Elhassan California SE No. 3930</p>	<p>Page:</p> <p style="font-size: 2em; font-weight: bold; margin-top: 10px;">2i.1</p>
	<p style="font-size: small;">OSHPD COMPLIANCE</p> <p style="font-size: x-small;">BY: Jeffrey Y. Kikumoto DATE: 03/03/2020</p>	

Pre-Designed Solutions (Trapeze Supported Pipe, Conduit, Cable Tray & Ductwork)

TRAPEZE SUPPORTED COMPONENTS (MULTIPLE PIPES, MULTIPLE CONDUITS, CABLE TRAY & DUCTWORK)

MAX LATERAL FORCE $F_p = 0.40W_p$ (ASD)

MAX VERTICAL FORCE $E_v = 0.25W_p$ (ASD)

MAXIMUM BRACE ANGLE = 60° FROM HORIZONTAL

$a_p = 2.5$ $R_p = 6$

	I	II	III	IV	V	VI	VII	VIII	IX	X					
Max Weight	Max Brace Spacing (ft.) ⁶	Max Vertical Support Spacing (ft.)	2/3 Gravity Weight (lbs.)	E_p (ASD) (lbs.)	W_p (lbs.)	F_p (ASD) (lbs.)	H Max (ft.)	Max Brace Length (ft.)	Min Brace Size	Min Vertical Rod Diameter Size	Max Rod Stiffener Spacing "L" (in.)	Trapeze Beam	Fitting	Brace Connection to Structure	Vertical Rod Connection to Structure
10.00 plf	20	10	66.67	16.67	200.00	80.00	9.06	10	P1000	3/8"	21	See Note 4	See Note 1	See Note 2	See Note 3
15.00 plf	20	10	100.00	25.00	300.00	120.00	9.06	10	P1000	3/8"	18				
30.00 plf	20	10	200.00	50.00	600.00	240.00	9.06	10	P1000	3/8"	12				
45.00 plf	20	10	300.00	75.00	900.00	360.00	9.06	10	P1000	1/2"	18				

Notes:

1. All fittings shown in Section 5 are acceptable to be used with trapeze restraints in the table above, except SPF200 for trapeze supporting 45 plf or more.
2. All types of connections shown in Section 7 are acceptable to be used with the trapeze restraints in the table above, except for the following connections:
 - a. Trapeze supporting 15 plf of weight:
 - i. (1) 1/2" diameter anchor w/ 2 1/4" EMB. into LWC
 - b. Trapeze supporting 30 plf of weight:
 - i. (1) 1/2" diameter anchor w/ 2 1/4" EMB. into either LWC or NWC
 - ii. (1) 1/2" diameter anchor w/ 3 1/4" EMB. into LWC
 - iii. (1) 5/8" diameter anchor w/ 3 1/4" EMB. into LWC
 - c. Trapeze supporting 45 plf of weight:
 - i. (1) 1/2" diameter anchor w/ 2 1/4" EMB. into either LWC or NWC
 - ii. (1) 1/2" diameter anchor w/ 3 1/4" EMB. into LWC
 - iii. (1) 5/8" diameter anchor w/ 3 1/4" EMB. into LWC
 - iv. (2) 3/8" diameter anchors w/ 2" EMB. into LWC
 - v. (2) 1/2" diameter anchors w/ 2 1/4" EMB. into LWC
3. See Note 3.1 for trapeze supporting up to 15 plf weight; See Note 3.2 for trapeze supporting more than 15 plf.
 - 3.1. For trapeze supporting up to 15 plf as tabulated above, all types of connections shown in Section 7 are acceptable to be used, except for the following connections:
 - i. (1) 3/8" diameter anchor w/ 2" EMB. into LWC
 - ii. (1) 1/2" diameter anchor w/ 2 1/4" EMB. into LWC
 - 3.2 For trapeze supporting more than 15 plf as tabulated above, only the following connection types are acceptable:
 - i. (1) 1/2" diameter bolt w/ 3 1/4" EMB., (1) 5/8" diameter anchor bolt w/ 3 1/4" or 4 1/4" EMB. into NWC
 - ii. (2) 1/2" diameter bolts w/ 3 1/4" EMB. into NWC
4. Trapeze beam shall be sized based on actual span in accordance with 4b.0 through 4b.6.
5. These tables are based on a maximum S_{DS} of 1.78g. Any S_{DS} above 1.78g requires an RDP or SEOR review.
6. Cable Tray restraint spacing shall be approved on a project specific basis, or preapproved by OSHPD. Spacing limits set by the manufacturer shall not be exceeded.

<p style="font-size: 10px; margin-top: 10px;">16100 S. Lathrop Ave Harvey, IL 60426 Toll-Free: (800) 882-5543</p> <p style="font-size: 8px; margin-top: 5px;">www.unistrutseismic.com</p>	<p style="font-weight: bold; font-size: 12px; margin-top: 5px;">Structural Engineer: Rami Elhassan California SE No. 3930</p>	<p>Page:</p> <p style="font-size: 24px; font-weight: bold; margin-top: 10px;">2i.2</p>
	<p style="font-size: 10px; margin-top: 5px;">www.unistrutseismic.com</p>	

Pre-Designed Solutions (Trapeze Supported Pipe, Conduit, Cable Tray & Ductwork)

TRAPEZE SUPPORTED COMPONENTS (MULTIPLE PIPES, MULTIPLE CONDUITS, CABLE TRAY & DUCTWORK)

MAX LATERAL FORCE $F_p = 0.55 W_p$ (ASD)

MAX VERTICAL FORCE $E_v = 0.25 W_p$ (ASD)

MAXIMUM BRACE ANGLE = 60° FROM HORIZONTAL

$a_p = 2.5$ $R_p = 6$

	I	II	III	IV	V	VI	VII	VIII	IX	X					
Max Weight															
Max Brace Spacing (ft.) ⁶															
Max Vertical Support Spacing (ft.)															
2/3 Gravity Weight (lbs.)															
E_p (ASD) (lbs.)															
W_p (lbs.)															
F_p (ASD) (lbs.)															
H Max (ft.)															
Max Brace Length (ft.)															
Min Brace Size															
Min Vertical Rod Diameter Size															
Max Rod Stiffener Spacing "L" (in.)															
Trapeze Beam															
Fitting															
Brace Connection to Structure															
Vertical Rod Connection to Structure															
10.00 plf	20	10	66.67	16.67	200.00	110.00	9.06	10	P1000	3/8"	18	See Note 4	See Note 1	See Note 2	See Note 3
15.00 plf	20	10	100.00	25.00	300.00	165.00	9.06	10	P1000	3/8"	15				
30.00 plf	20	10	200.00	50.00	600.00	330.00	9.06	10	P1000	1/2"	18				
45.00 plf	15	10	300.00	75.00	675.00	371.25	9.06	10	P1000	1/2"	18				

Notes:

1. All fittings shown in Section 5 are acceptable to be used with trapeze restraints in the table above, except SPF200 for trapeze supporting 45 plf or more.
2. All types of connections shown in Section 7 are acceptable to be used with the trapeze restraints in the table above, except for the following connections:
 - a. Trapeze supporting 15 plf of weight:
 - i. (1) 1/2" diameter anchor w/ 2 1/4" EMB. into LWC
 - ii. (1) 5/8" diameter anchor w/ 3 1/4" EMB. into LWC
 - b. Trapeze supporting 30 plf or 45 plf of weight:
 - i. (1) 1/2" diameter anchor w/ 2 1/4" EMB. into either LWC or NWC
 - ii. (1) 1/2" diameter anchor w/ 3 1/4" EMB. into LWC
 - iii. (1) 5/8" diameter anchor w/ 3 1/4" EMB. into LWC
 - iv. (2) 3/8" diameter anchors w/ 2" EMB. into LWC
 - v. (2) 1/2" diameter anchors w/ 2 1/4" EMB. into LWC
3. See Note 3.1 for trapeze supporting up to 15 plf weight; See Note 3.2 for trapeze supporting more than 15 plf.
 - 3.1. For trapeze supporting up to 15 plf as tabulated above, all types of connections shown in Section 7 are acceptable to be used, except for the following connections:
 - i. (1) 3/8" diameter anchor w/ 2" EMB. into LWC
 - ii. (1) 1/2" diameter anchor w/ 2 1/4" EMB. into LWC
 - 3.2 For trapeze supporting more than 15 plf as tabulated above, only the following connection types are acceptable:
 - i. (1) 5/8" diameter anchor bolt w/ 3 1/4" or 4 1/4" EMB. into NWC
 - ii. (2) 1/2" diameter bolts w/ 3 1/4" EMB. into NWC
4. Trapeze beam shall be sized based on actual span in accordance with 4b.0 through 4b.6.
5. These tables are based on a maximum S_{DS} of 1.78g. Any S_{DS} above 1.78g requires an RDP or SEOR review.
6. Cable Tray restraint spacing shall be approved on a project specific basis, or preapproved by OSHPD. Spacing limits set by the manufacturer shall not be exceeded.

 <p style="text-align: center;">16100 S. Lathrop Ave Harvey, IL 60426 Toll-Free: (800) 882-5543</p> <p style="text-align: center;">www.unistrutseismic.com</p>	 Structural Engineer: Rami Elhassan California SE No. 3930	Page: <h2 style="text-align: center;">2i.3</h2>
	<p>OPM-0295-13</p>	

Restraint Methods

RIGID (CHANNEL OR TELESPAR) RESTRAINTS

Single System Component

See Pages 3a.1 - 3a.2

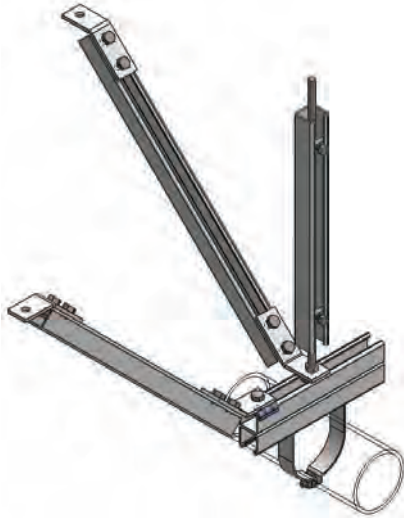

Uses:

- 1) Individual Pipe or Conduit run

TRAPEZE SUPPORTED SYSTEMS

OPM-0295-13

See Pages 3b.1 - 3e.2

DATE: 03/02/2020

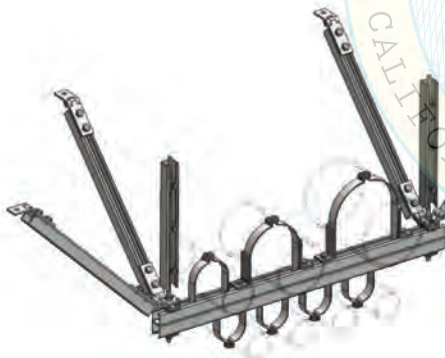

Uses:

- 1) Multiple Pipe or Conduit run
- 2) Cable Tray
- 3) Ductwork

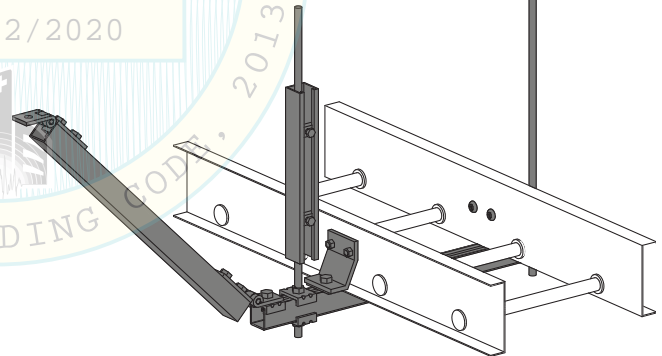

Atkore[™]
Unistrut

16100 S. Lathrop Ave
Harvey, IL 60426
Toll-Free: (800) 882-5543

www.unistrutseismic.com

Rami Elhassan
Structural Engineer: Rami Elhassan
California SE No. 3930

Page:

3a.0

Restraint Details - Pipe, Conduit & Tube (Single)

SINGLE PIPE OR CONDUIT TRANSVERSE RESTRAINT TYPE

See section 7 for structural attachments for hangers and brace

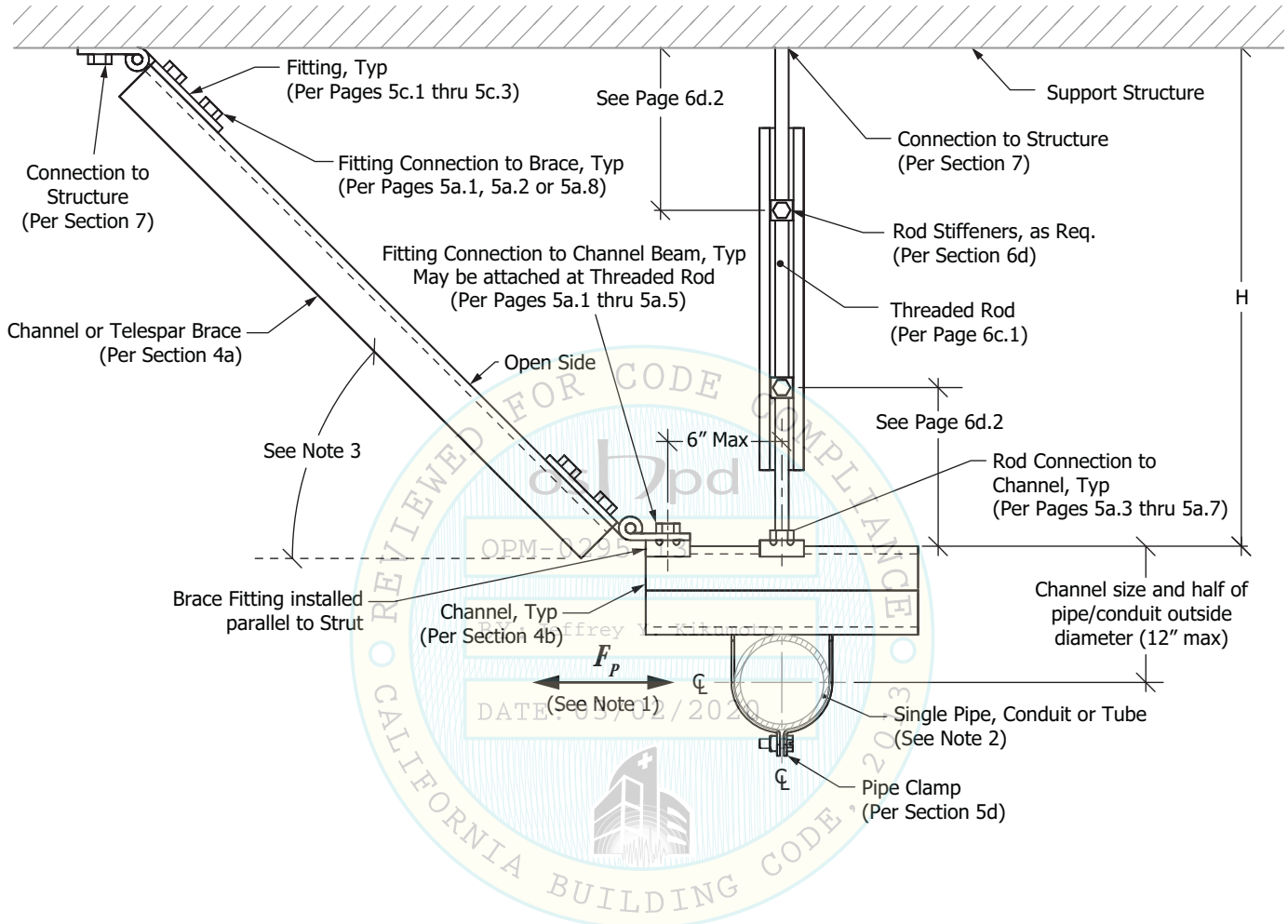

Notes:

- 1) F_p shall be calculated for each case. F_p shall not exceed the maximum capacities for any of the components used to support the system.
- 2) Maximum pipe, conduit or tube size per General Notes (Page 1g.1). See Appendix for weight of pipe, conduit or tube.
- 3) Braces can be installed at angles 0° to 60° from horizontal.
- 4) Fittings and Hardware shown are for graphical representation only. Final configuration may use any fitting or hardware component included in this OPM provided it has sufficient capacity and is used for its correct intent.

Atkore
Unistrut

16100 S. Lathrop Ave
Harvey, IL 60426
Toll-Free: (800) 882-5543

www.unistrutseismic.com

Rami Elhassan

Structural Engineer: Rami Elhassan
California SE No. 3930

Page:

3a.1

Restraint Details - Pipe, Conduit & Tube (Single)

SINGLE PIPE OR CONDUIT LONGITUDINAL RESTRAINT TYPE

See section 7 for structural attachments for hangers and brace

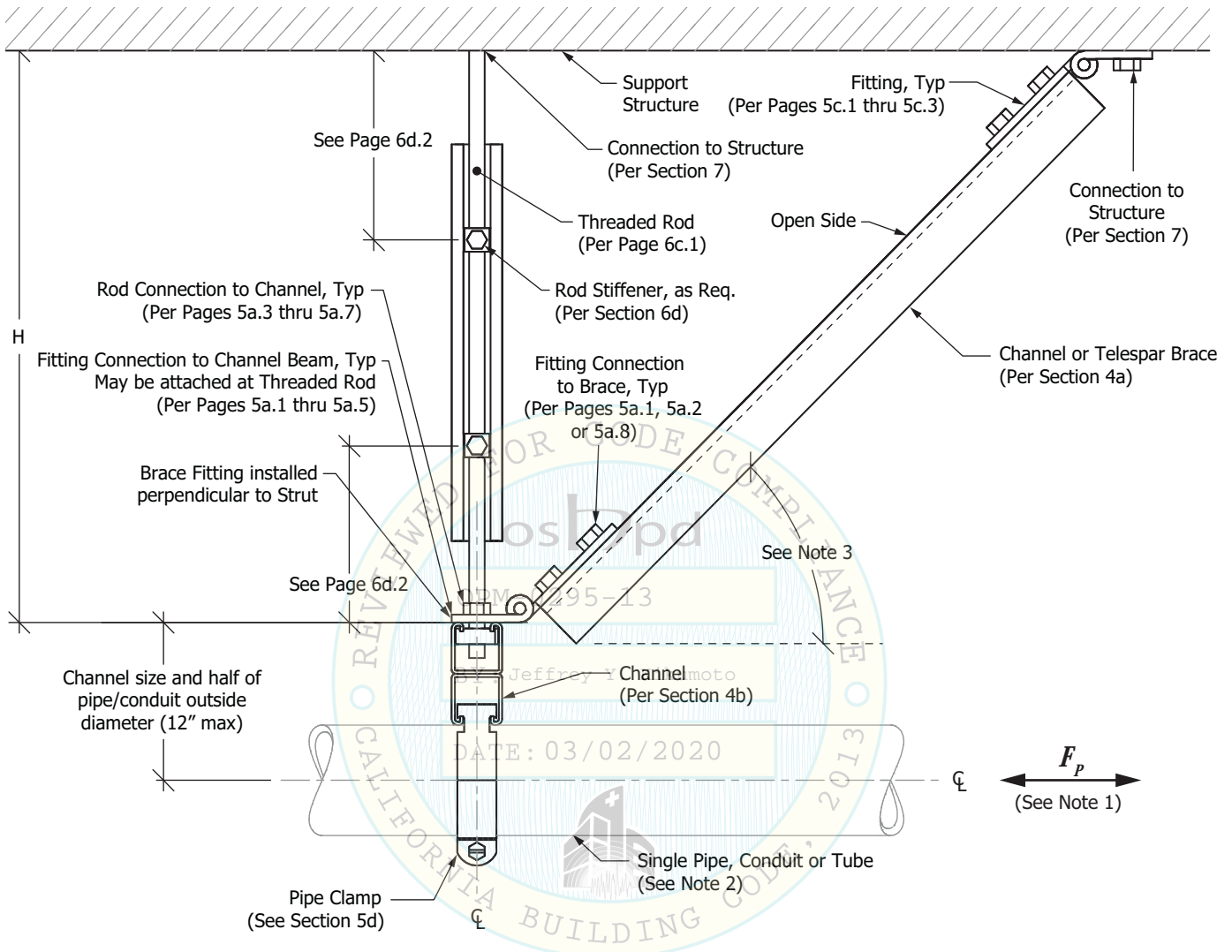

Notes:

- 1) F_p shall be calculated for each case. F_p shall not exceed the maximum capacities for any of the components used to support the system.
- 2) Maximum pipe, conduit or tube size per General Notes (Page 1g.1). See Appendix for weight of pipe, conduit or tube.
- 3) Braces can be installed at angles 0° to 60° from horizontal.
- 4) Fittings and Hardware shown are for graphical representation only. Final configuration may use any fitting or hardware component included in this OPM provided it has sufficient capacity and is used for its correct intent.

Atkore
Unistrut

16100 S. Lathrop Ave
Harvey, IL 60426
Toll-Free: (800) 882-5543

www.unistrutseismic.com

Rami Elhassan
Structural Engineer: Rami Elhassan
California SE No. 3930

Page:

3a.2

Restraint Details - Pipe, Conduit & Tube (Trapeze)

TRAPEZE SUPPORT TRANSVERSE RESTRAINT TYPE

See section 7 for structural attachments for hangers and brace

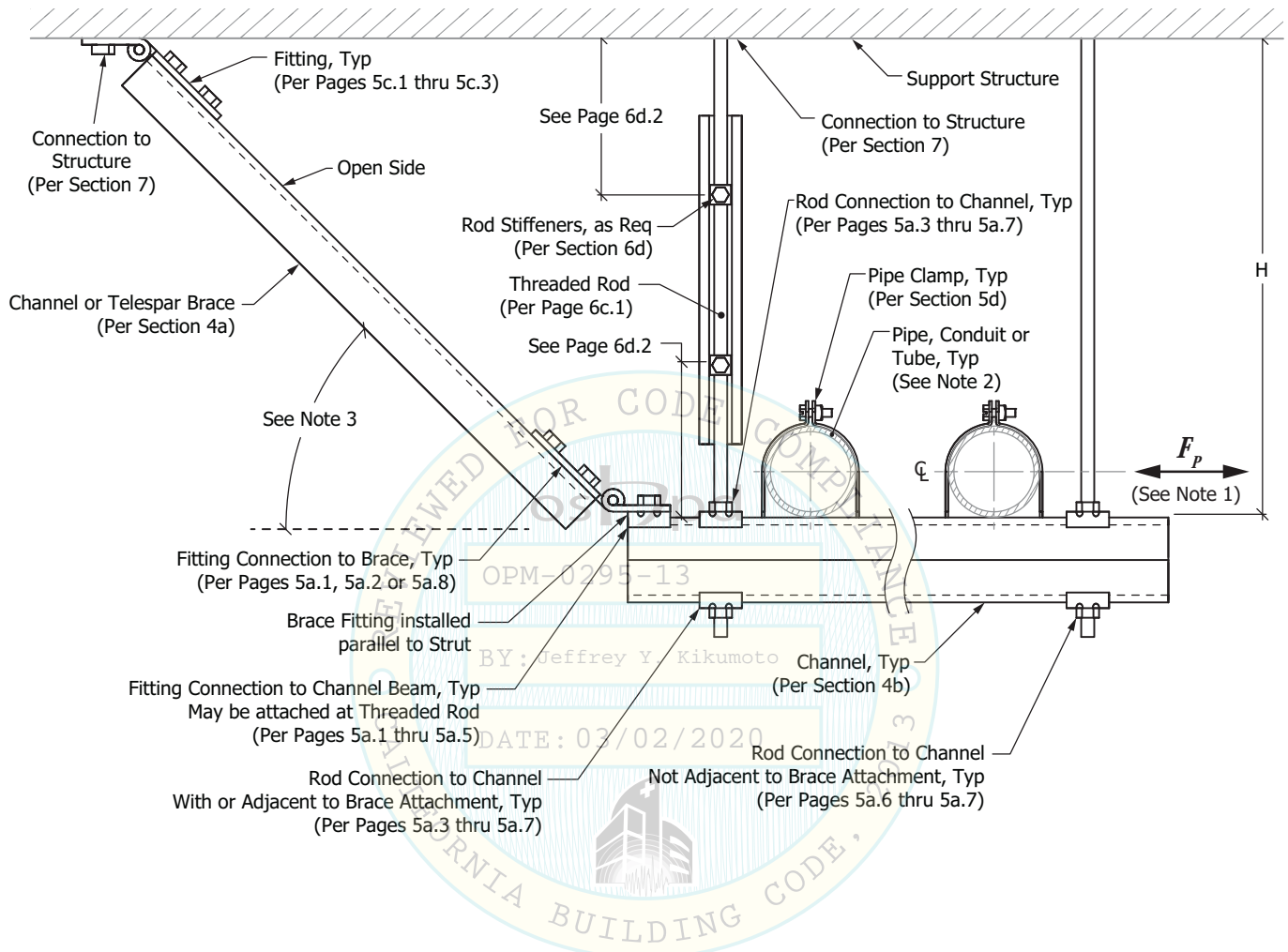

Notes:

- 1) F_p shall be calculated for each case. F_p shall not exceed the maximum capacities for any of the components used to support the system.
- 2) Maximum pipe, conduit or tube size per General Notes (Page 1g.1). See Appendix for weight of pipe, conduit or tube.
- 3) Braces can be installed at angles 0° to 60° from horizontal.
- 4) Fittings and Hardware shown are for graphical representation only. Final configuration may use any fitting or hardware component included in this OPM provided it has sufficient capacity and is used for its correct intent.

Atkore
Unistrut

16100 S. Lathrop Ave
Harvey, IL 60426
Toll-Free: (800) 882-5543

www.unistrutseismic.com

Rami Elhassan

Structural Engineer: Rami Elhassan
California SE No. 3930

Page:

3b.1

Restraint Details - Pipe, Conduit & Tube (Trapeze)

TRAPEZE SUPPORT LONGITUDINAL RESTRAINT TYPE

See section 7 for structural attachments for hangers and brace

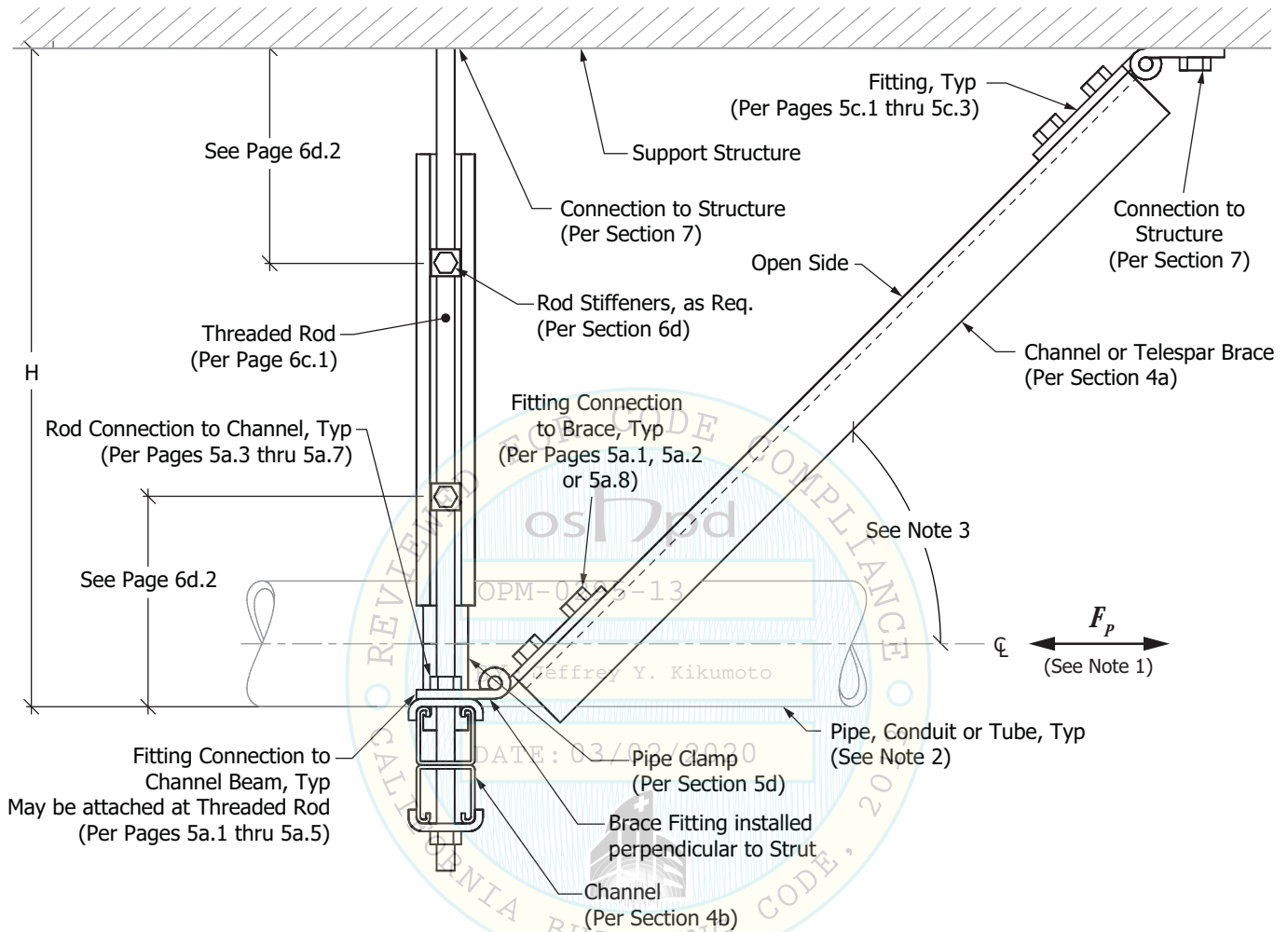

Notes:

- 1) F_p shall be calculated for each case. F_p shall not exceed the maximum capacities for any of the components used to support the system.
- 2) Maximum pipe, conduit or tube size per General Notes (Page 1g.1). See Appendix for weight of pipe, conduit or tube.
- 3) Braces can be installed at angles 0° to 60° from horizontal.
- 4) Fittings and Hardware shown are for graphical representation only. Final configuration may use any fitting or hardware component included in this OPM provided it has sufficient capacity and is used for its correct intent.

Atkore
Unistrut

16100 S. Lathrop Ave
Harvey, IL 60426
Toll-Free: (800) 882-5543

www.unistrutseismic.com

Rami Elhassan
Structural Engineer: Rami Elhassan
California SE No. 3930

Page:

3b.2

Restraint Details - Rectangular Duct (Trapeze)

TRAPEZE SUPPORT TRANSVERSE RESTRAINT TYPE:

See section 7 for structural attachments for hangers and brace

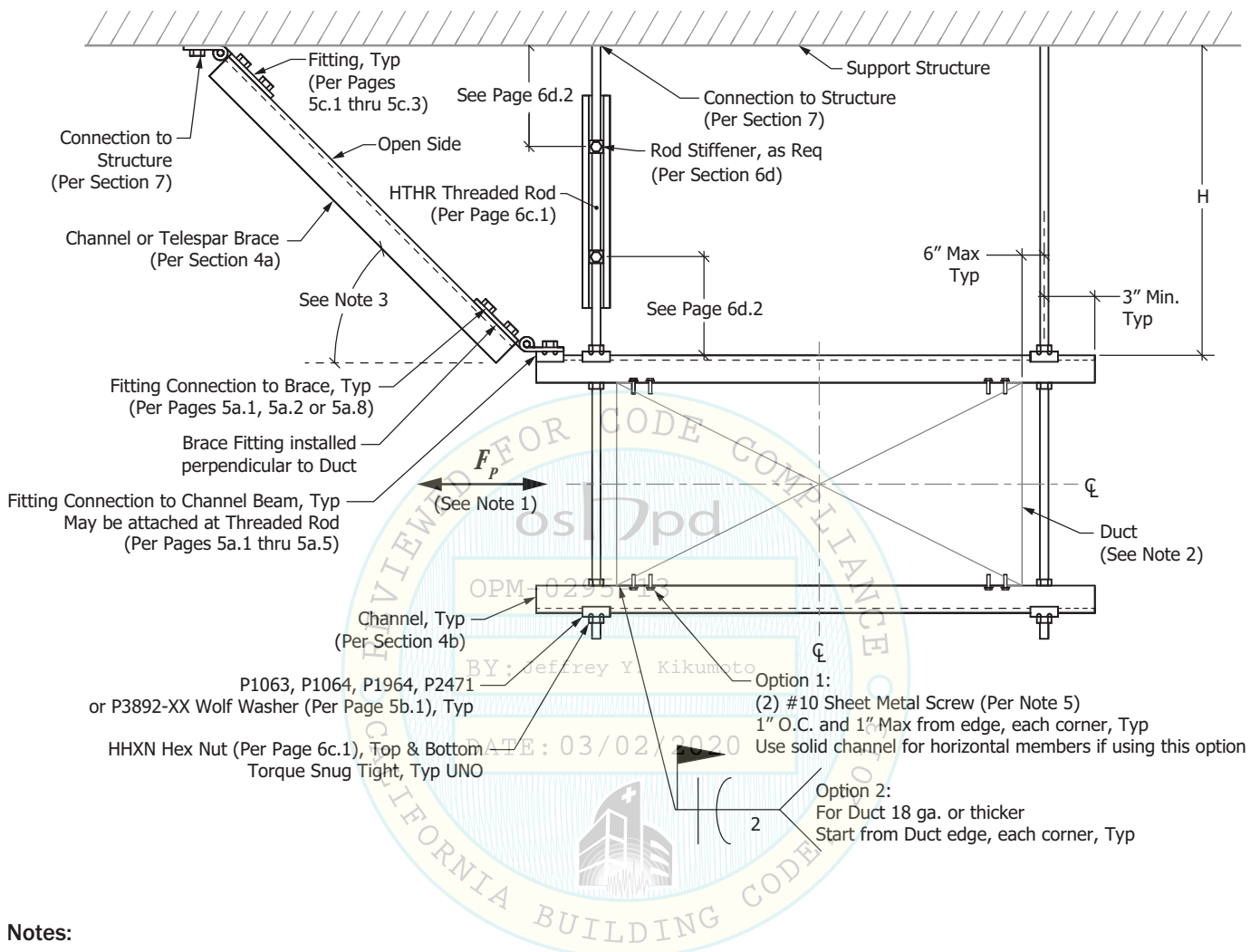

Notes:

- 1) F_p shall be calculated for each case. F_p shall not exceed the maximum capacities for any of the components used to support the system.
- 2) Maximum duct size per General Notes (Page 1g.1). See Appendix for weight of Duct.
- 3) Braces that project to the overhead structure shall be installed between 30° and 60° from horizontal. Where an adjacent wall occurs, braces that project to that wall shall be installed directly horizontal (0°).
- 4) Fittings and Hardware shown are for graphical representation only. Final configuration may use any fitting or hardware component included in this OPM provided it has sufficient capacity and is used for its correct intent.
- 5) Approved Sheet Metal Screws (#10 Size): ITW Buildex (ESR-1976 & ESR 3223), Simpson Strong-Tie (ESR-3006), Darts (ER-5202), Elco (ESR-3294), and Hilti (ESR-2196).

Atkore
Unistrut

16100 S. Lathrop Ave
Harvey, IL 60426
Toll-Free: (800) 882-5543

www.unistrutseismic.com

Rami Elhassan
Structural Engineer: Rami Elhassan
California SE No. 3930

Page:

3c.1

Restraint Details - Rectangular Duct (Trapeze)

TRAPEZE SUPPORT LONGITUDINAL RESTRAINT TYPE

See section 7 for structural attachments for hangers and brace

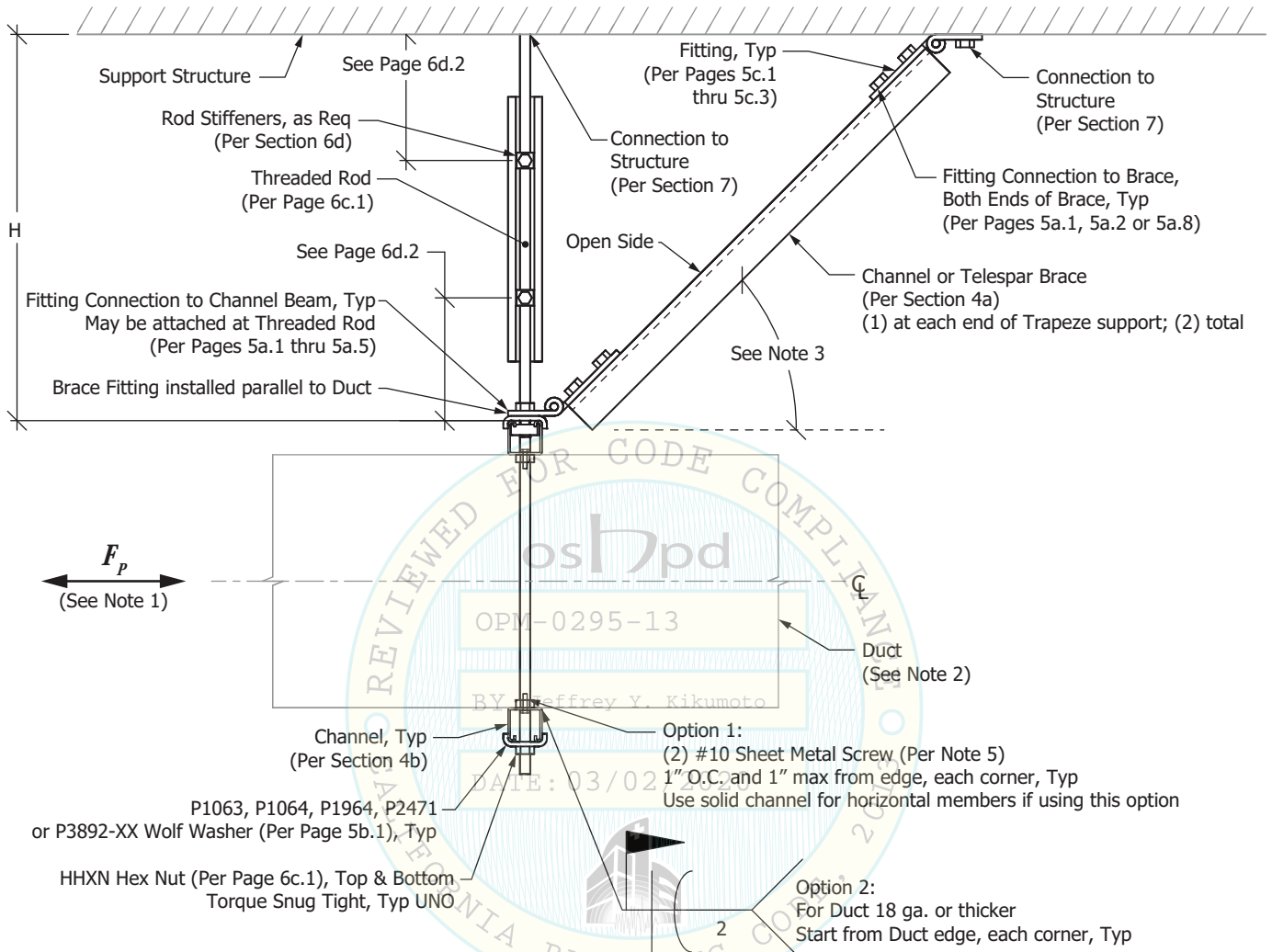

Notes:

- 1) F_p shall be calculated for each case. F_p shall not exceed the maximum capacities for any of the components used to support the system.
- 2) Maximum duct size per General Notes (Page 1g.1). See Appendix for weight of Duct.
- 3) Braces that project to the overhead structure shall be installed between 30° and 60° from horizontal. Where an adjacent wall occurs, braces that project to that wall shall be installed directly horizontal (0°).
- 4) Fittings and Hardware shown are for graphical representation only. Final configuration may use any fitting or hardware component included in this OPM provided it has sufficient capacity and is used for its correct intent.
- 5) Approved Sheet Metal Screws (#10 Size): ITW Buildex (ESR-1976 & ESR 3223), Simpson Strong-Tie (ESR-3006), Darts (ER-5202), Elco (ESR-3294), and Hilti (ESR-2196).

Atkore
Unistrut

16100 S. Lathrop Ave
Harvey, IL 60426
Toll-Free: (800) 882-5543

www.unistrutseismic.com

Rami Elhassan
Structural Engineer: Rami Elhassan
California SE No. 3930

Page:

3c.2

Restraint Details - Round Duct (Single)

ROUND DUCT SUPPORT TRANSVERSE RESTRAINT TYPE

See section 7 for structural attachments for hangers and brace

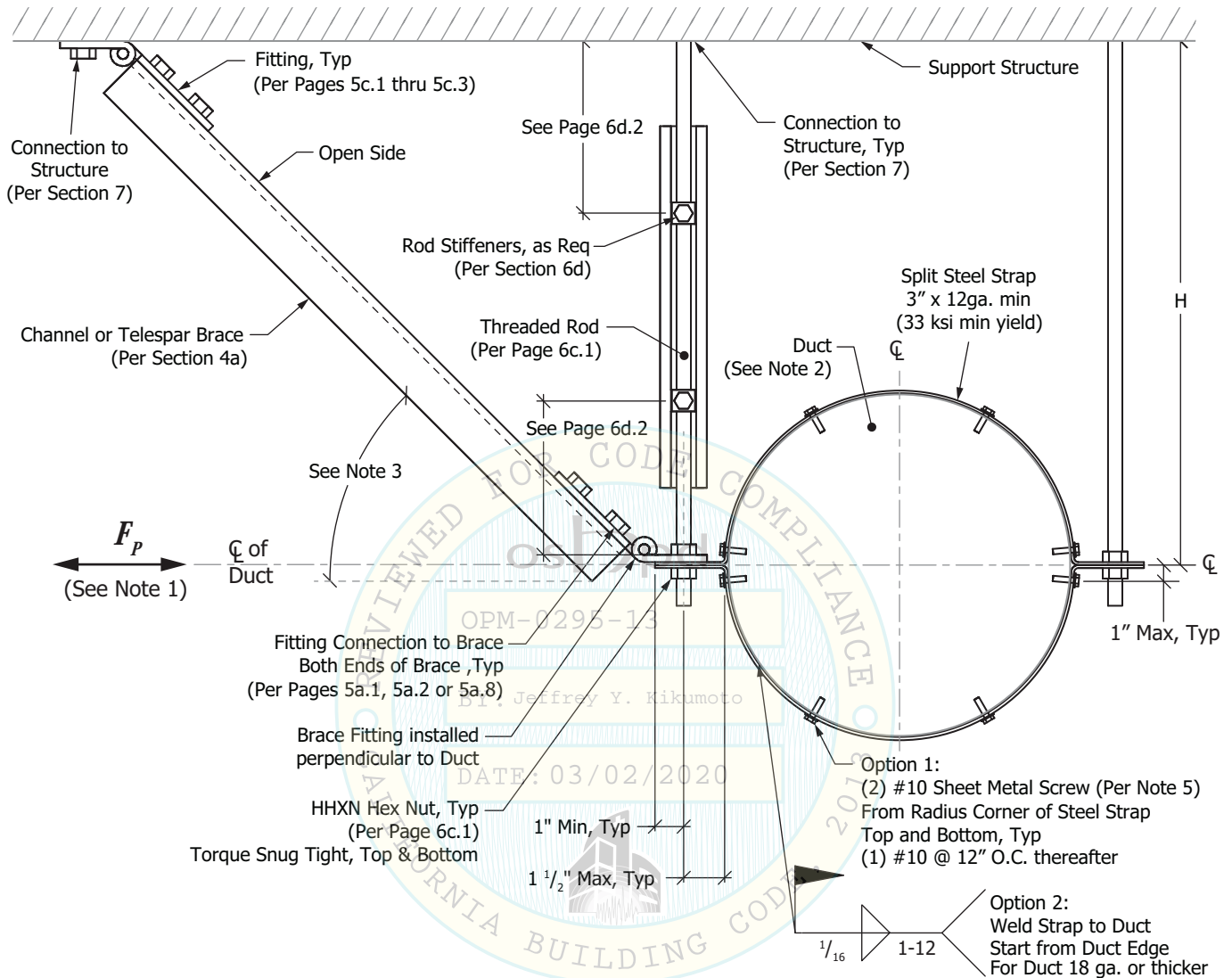

Notes:

- 1) F_p shall be calculated for each case. F_p shall not exceed the maximum capacities for any of the components used to support the system.
- 2) Maximum duct size per General Notes (Page 1g.1). See Appendix for weight of Duct.
- 3) Braces that project to the overhead structure shall be installed between 30° and 60° from horizontal. Where an adjacent wall occurs, braces that project to that wall shall be installed directly horizontal (0°).
- 4) Fittings and Hardware shown are for graphical representation only. Final configuration may use any fitting or hardware component included in this OPM provided it has sufficient capacity and is used for its correct intent.
- 5) Approved Sheet Metal Screws (#10 Size): ITW Buildex (ESR-1976 & ESR 3223), Simpson Strong-Tie (ESR-3006), Darts (ER-5202), Elco (ESR-3294), and Hilti (ESR-2196).

Atkore
Unistrut

16100 S. Lathrop Ave
Harvey, IL 60426
Toll-Free: (800) 882-5543

www.unistrutseismic.com

Rami Elhassan

Structural Engineer: Rami Elhassan
California SE No. 3930

Page:

3d.1

Restraint Details - Round Duct (Single)

ROUND DUCT SUPPORT LONGITUDINAL RESTRAINT TYPE

See section 7 for structural attachments for hangers and brace

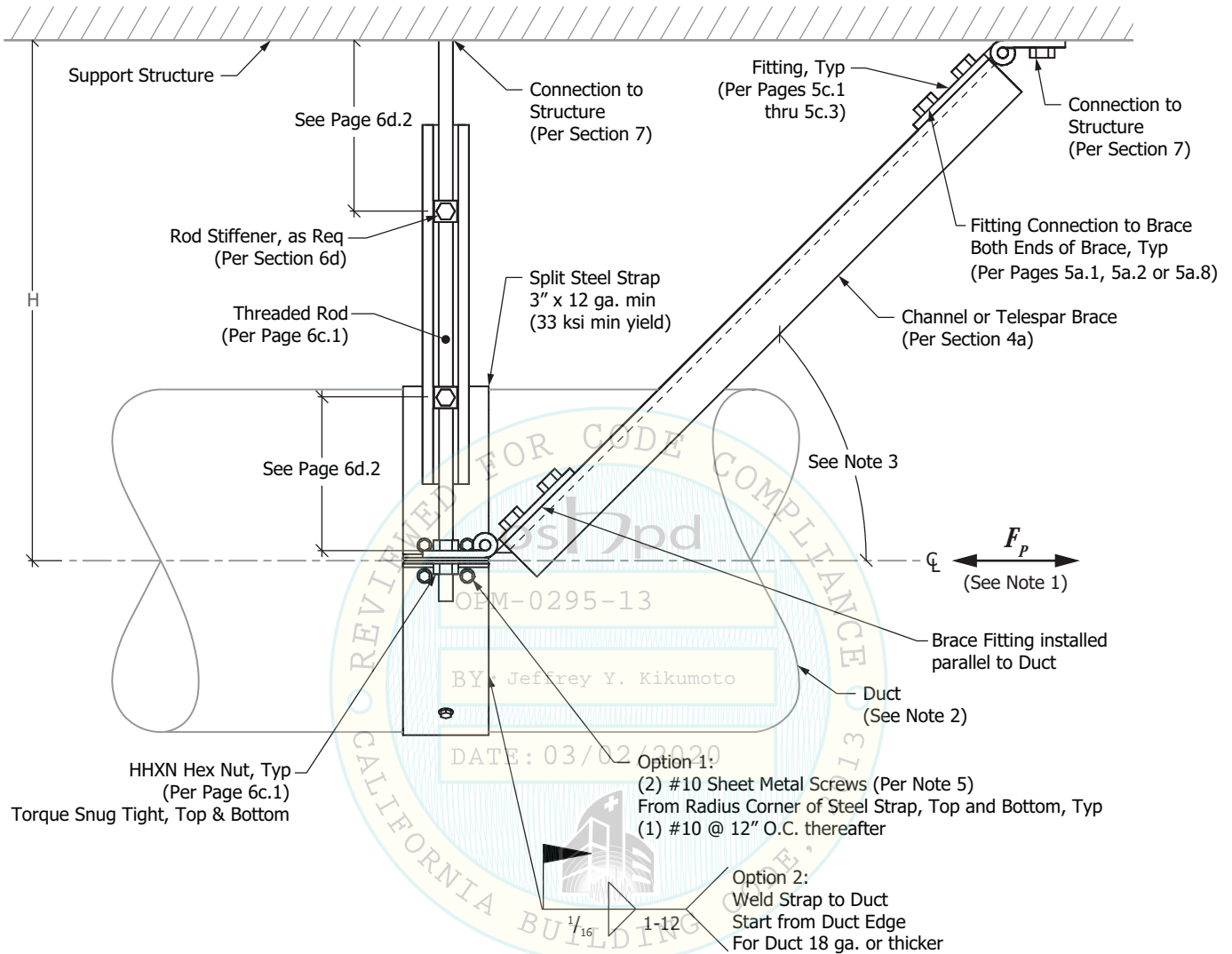

Notes:

- 1) F_p shall be calculated for each case. F_p shall not exceed the maximum capacities for any of the components used to support the system.
- 2) Maximum duct size per General Notes (Page 1g.1). See Appendix for weight of Duct.
- 3) Braces that project to the overhead structure shall be installed between 30° and 60° from horizontal. Where an adjacent wall occurs, braces that project to that wall shall be installed directly horizontal (0°).
- 4) Fittings and Hardware shown are for graphical representation only. Final configuration may use any fitting or hardware component included in this OPM provided it has sufficient capacity and is used for its correct intent.
- 5) Approved Sheet Metal Screws (#10 Size): ITW Buildex (ESR-1976 & ESR 3223), Simpson Strong-Tie (ESR-3006), Darts (ER-5202), Elco (ESR-3294), and Hilti (ESR-2196).

Atkore
Unistrut

16100 S. Lathrop Ave
Harvey, IL 60426
Toll-Free: (800) 882-5543

www.unistrutseismic.com

Rami Elhassan

Structural Engineer: Rami Elhassan
California SE No. 3930

Page:

3d.2

Restraint Detail - Cable Tray (Trapeze)

TRAPEZE SUPPORT TRANSVERSE RESTRAINT TYPE

See section 7 for structural attachments for hangers and brace

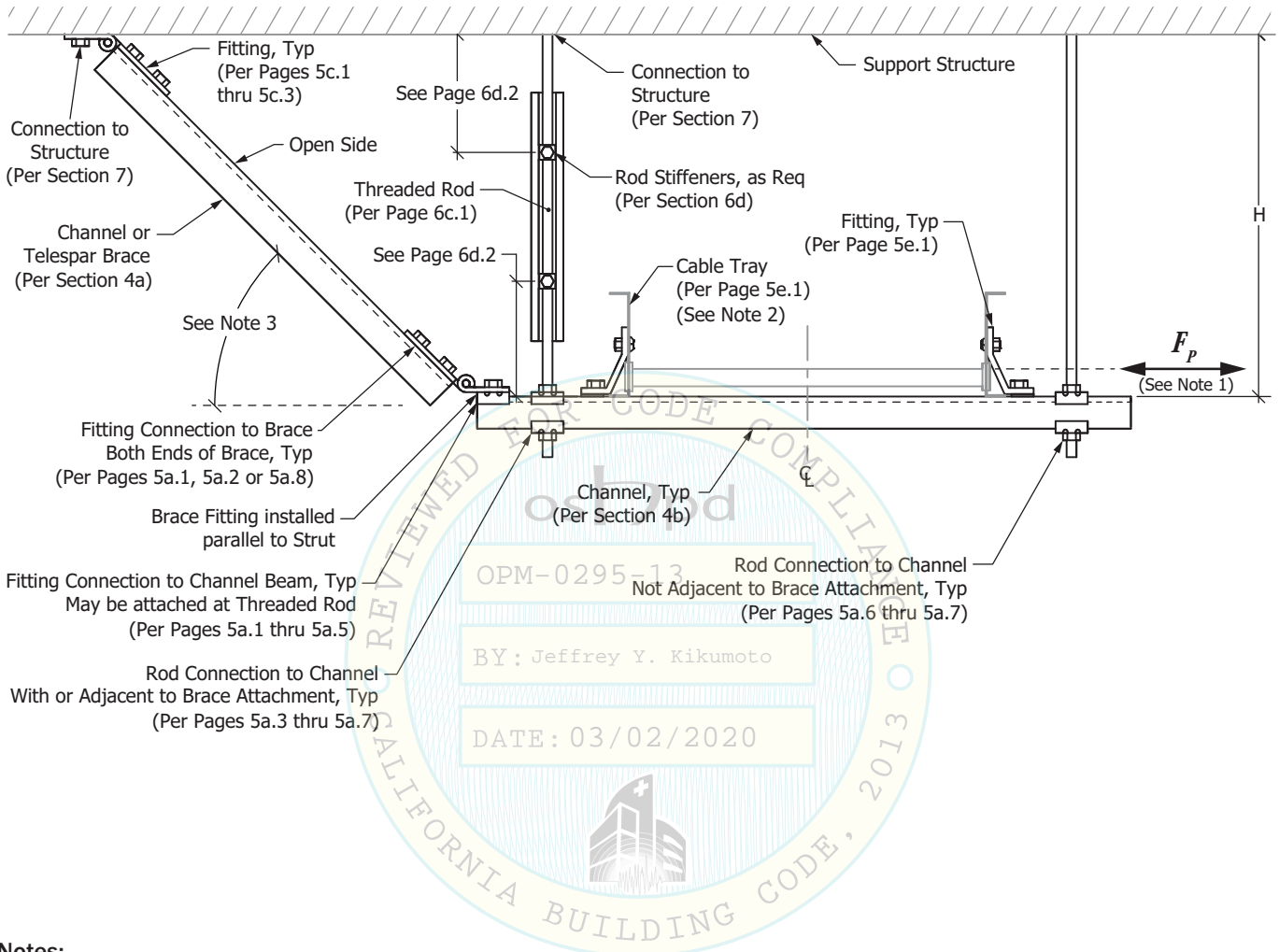

Notes:

- 1) F_p shall be calculated for each case. F_p shall not exceed the maximum capacities for any of the components used to support the system.
- 2) Maximum Cable Tray size per General Notes (Page 1g.1). See Appendix for weight of Cable Tray.
- 3) Braces can be installed at angles 0° to 60° from horizontal.
- 4) Fittings and Hardware shown are for graphical representation only. Final configuration may use any fitting or hardware component included in this OPM provided it has sufficient capacity and is used for its correct intent.
- 5) Cable Tray shall be approved on a project specific basis, or preapproved by OSHPD. Spacing limits set by the manufacturer shall not be exceeded. Cable Tray brace shall be approved or preapproved by OSHPD.

Atkore
Unistrut

16100 S. Lathrop Ave
Harvey, IL 60426
Toll-Free: (800) 882-5543

www.unistrutseismic.com

Structural Engineer: Rami Elhassan
California SE No. 3930

Page:

3e.1

Restraint Detail - Cable Tray (Trapeze)

TRAPEZE SUPPORT LONGITUDINAL RESTRAINT TYPE

See section 7 for structural attachments for hangers and brace

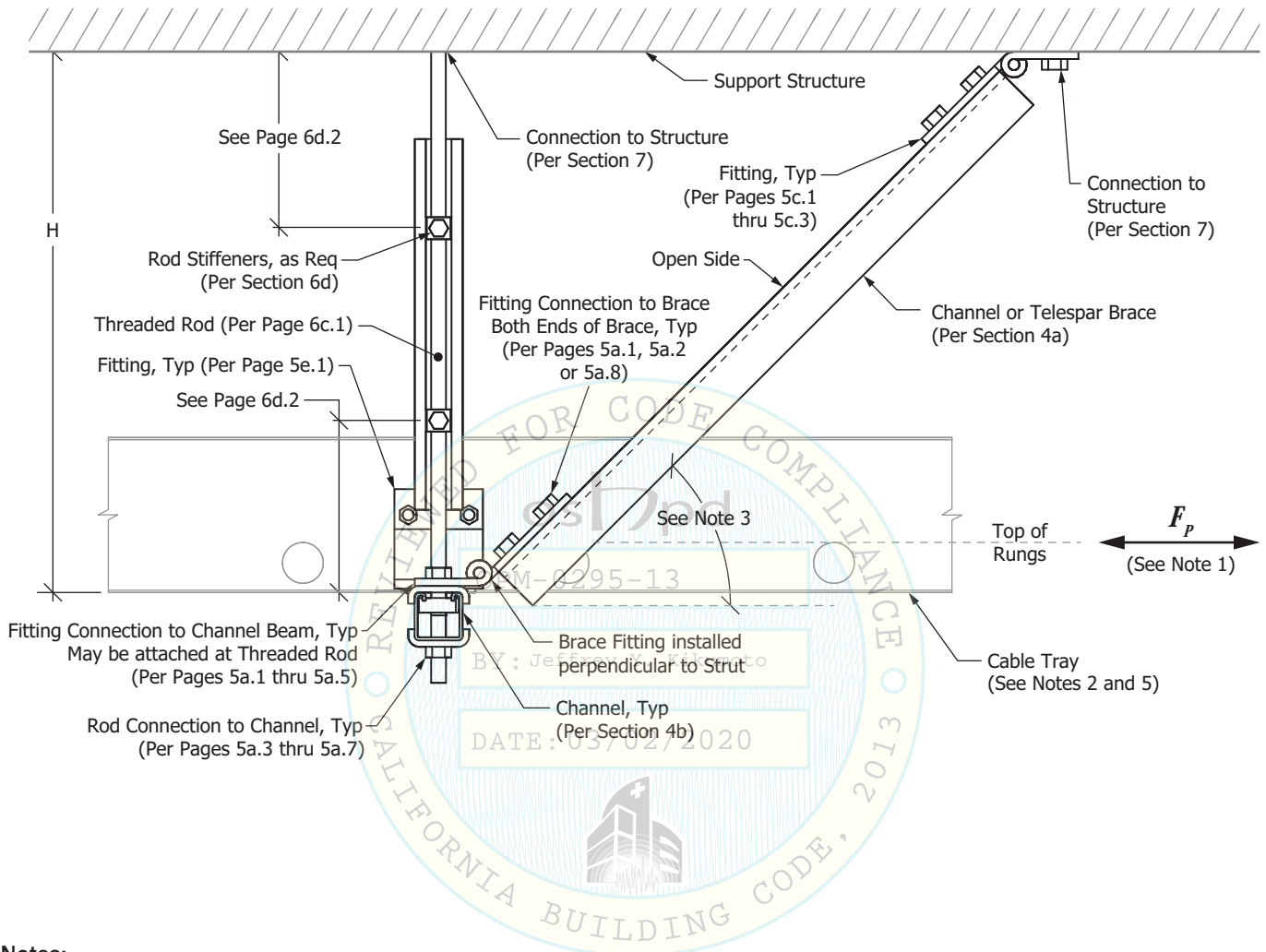

Notes:

- 1) F_p shall be calculated for each case. F_p shall not exceed the maximum capacities for any of the components used to support the system.
- 2) Maximum Cable Tray size per General Notes (Page 1g.1). See Appendix for weight of Cable Tray.
- 3) Braces can be installed at angles 0° to 60° from horizontal.
- 4) Fittings and Hardware shown are for graphical representation only. Final configuration may use any fitting or hardware component included in this OPM provided it has sufficient capacity and is used for its correct intent.
- 5) Cable Tray shall be approved on a project specific basis, or preapproved by OSHPD. Spacing limits set by the manufacturer shall not be exceeded. Cable Tray brace shall be approved or preapproved by OSHPD.

Atkore™
Unistrut

16100 S. Lathrop Ave
Harvey, IL 60426
Toll-Free: (800) 882-5543

www.unistrutseismic.com

Structural Engineer: Rami Elhassan
California SE No. 3930

Page:

3e.2

Components: Channel & Telespar

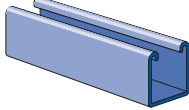
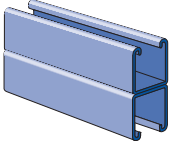
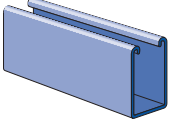
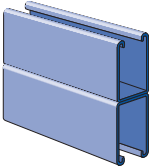
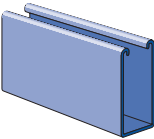
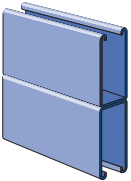
CHANNEL PART NUMBERS				PAGE
	P1000 P1000T	P1000WT P1000HS	1 5/8" x 1 5/8" x 12 ga.	4a.1 4b.1
	P1001 P1001T	P1001WT P1001HS	1 5/8" x 3 1/4" x 12 ga.	4a.2 4b.2
	P5500 P5500T	P5500WT P5500HS	1 5/8" x 2 7/16" x 12 ga.	4a.3 4b.3
	P5501 P5501T	P5501WT P5501HS	1 5/8" x 4 7/8" x 12 ga.	4a.4 4b.4
	P5000 P5000T	P5000WT P5000HS	1 5/8" x 3 1/4" x 12 ga.	4a.5 4b.5
	P5001 P5001T	P5001WT P5001HS	1 5/8" x 6 1/2" x 12 ga.	4a.6 4b.6

Channel Specifications:

- Material: Pre-galvanized (PG): ASTM A653 SS Grade 33
- Finish: Pre-galvanized (PG): ASTM A653 G90
- Thickness: 12 ga.

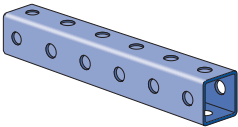
TELESPAR PART NUMBERS			PAGE
	20F12	2" x 2" x 12 ga.	4a.7
	24F12	2 1/2" x 2 1/2" x 12 ga.	4a.7

Telespar Specifications:

- Material: Pre-galvanized (PG): ASTM A653 SS Grade 50, Class 2 min.
- Finish: Pre-galvanized (PG): ASTM A653 G90
- Thickness: 12 ga.



16100 S. Lathrop Ave
Harvey, IL 60426
Toll-Free: (800) 882-5543

www.unistrutseismic.com

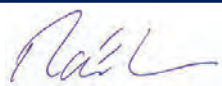
Structural Engineer: Rami Elhassan
California SE No. 3930

Page:

4a.0

Channel – Rigid Brace

P1000, P1000T, P1000WT, P1000HS - 1 5/8" X 1 5/8" X 12 GA.

PIERCED OPTIONS

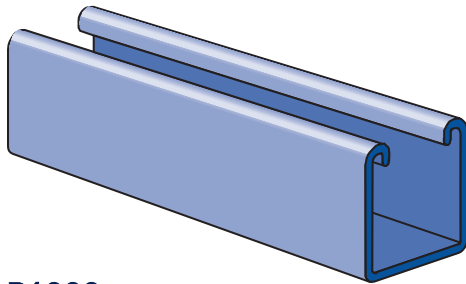

P1000

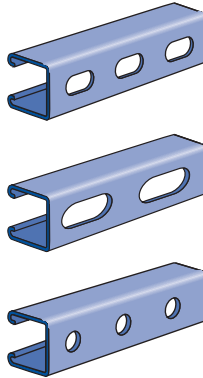

P1000T	3/16" x 1 1/8" Slots 2" on Center
P1000WT	11/16" x 2" Slots 3" on Center
P1000HS	3/16" Dia. Holes 1 7/8" on Center

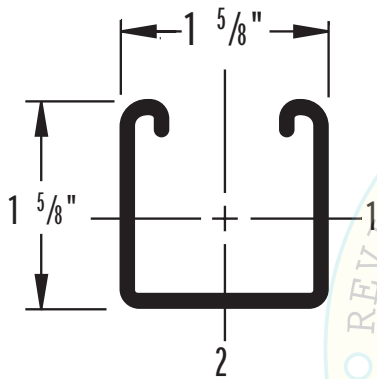

Span (ft.)	Maximum Horizontal F_p Force (lbs) [ASD]			
	Angle "A"			
	0° +5° / -0°	30° +5° / -25°	45° +5° / -10°	60° +0° / -10°
2'	3,440	2,970	2,430	1,720
3'	3,140	2,710	2,220	1,570
4'	2,750	2,380	1,940	1,370
5'	2,380	2,060	1,680	1,190
6'	2,080	1,800	1,470	1,040
7'	1,860	1,610	1,310	930
8'	1,670	1,440	1,180	830
9'	1,510	1,300	1,060	750
10'	1,380	1,190	970	690

Notes:

- 1) These values apply only to Unistrut brand products. Unistrut channels are stamped with the name "UNISTRUT".
- 2) Max F_p shown is based on P1000WT. Max F_p can be increased for different strut types based on section properties shown on page 4c.1.
- 3) Max allowable force F_p may be limited by the capacities of the brace fitting, channel nut or rod connection, trapeze support, anchorage, or capacity of another component.

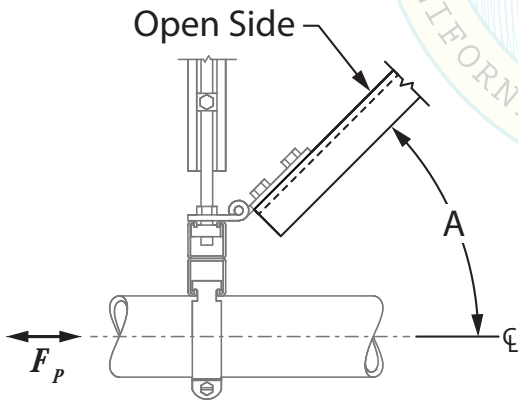

16100 S. Lathrop Ave
Harvey, IL 60426
Toll-Free: (800) 882-5543

www.unistrutseismic.com

Structural Engineer: Rami Elhassan
California SE No. 3930

Page:

4a.1

Channel – Rigid Brace

P1001, P1001T, P1001WT, P1001HS - 1 5/8" X 3 1/4" X 12 GA.

PIERCED OPTIONS

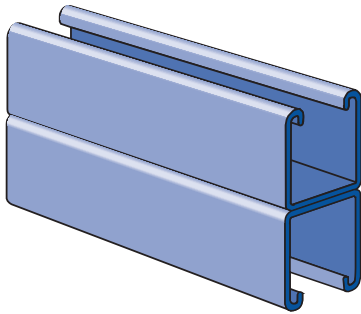

P1001

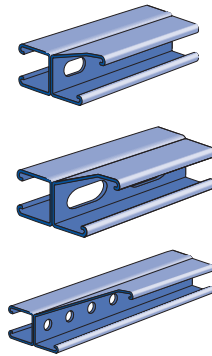

P1001T	9/16" x 1 1/8" Slots 2" on Center
P1001WT	1 1/16" x 2" Slots 3" on Center
P1001HS	9/16" Dia. Holes 1 7/8" on Center

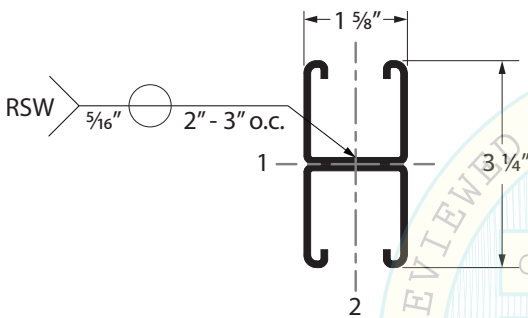

Span (ft.)	Angle "A"			
	0° +5° / -0°	30° +5° / -25°	45° +5° / -10°	60° +0° / -10°
2'	6,200	5,360	4,380	3,100
3'	6,070	5,250	4,290	3,030
4'	5,950	5,150	4,200	2,970
5'	5,800	5,020	4,100	2,900
6'	5,450	4,710	3,850	2,720
7'	5,040	4,360	3,560	2,520
8'	4,600	3,980	3,250	2,300
9'	4,140	3,580	2,920	2,070
10'	3,670	3,170	2,590	1,830
12'	2,900	2,510	2,050	1,450

Notes:

- 1) These values apply only to Unistrut brand products. Unistrut channels are stamped with the name "UNISTRUT".
- 2) Max F_p shown is based on P1001WT. Max F_p can be increased for different strut types based on section properties shown on page 4c.1.
- 3) Max allowable force F_p may be limited by the capacities of the brace fitting, channel nut or rod connection, trapeze support, anchorage, or capacity of another component.

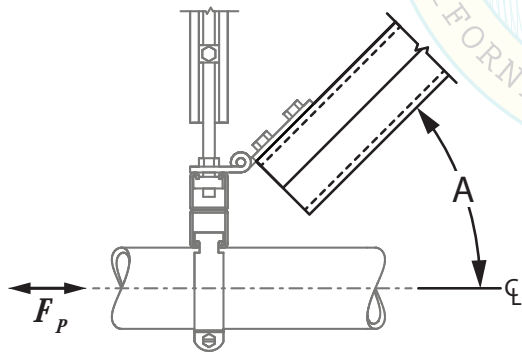

Atkore
Unistrut

16100 S. Lathrop Ave
Harvey, IL 60426
Toll-Free: (800) 882-5543

www.unistrutseismic.com

Rami Elhassan
Structural Engineer: Rami Elhassan
California SE No. 3930

Page:

4a.2

Channel – Rigid Brace

P5500, P5500T, P5500WT, P5500HS - 1 5/8" X 2 7/16" X 12 GA

PIERCED OPTIONS

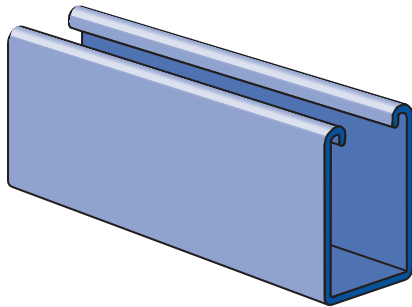

P5500

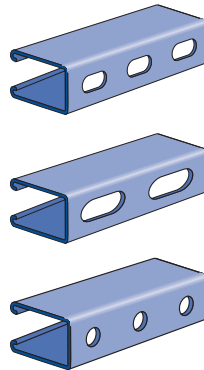

P5500T	3/16" x 1 1/8" Slots 2" on Center
P5500WT	11/16" x 2" Slots 3" on Center
P5500HS	3/16" Dia. Holes 1 7/8" on Center

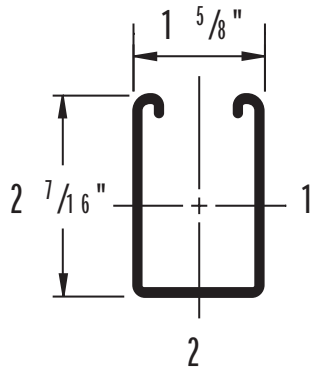

Span (ft.)	Maximum Horizontal F_p Force (lbs) [ASD]			
	Angle "A"			
	0° +5° / -0°	30° +5° / -25°	45° +5° / -10°	60° +0° / -10°
2'	4,500	3,890	3,180	2,250
3'	3,920	3,390	2,770	1,960
4'	3,180	2,750	2,240	1,590
5'	2,550	2,200	1,800	1,270
6'	2,120	1,830	1,490	1,060
7'	1,810	1,560	1,270	900
8'	1,580	1,360	1,110	790
9'	1,400	1,210	980	700
10'	1,270	1,090	890	630
12'	1,060	910	740	530
14'	920	790	650	460

Notes:

- 1) These values apply only to Unistrut brand products. Unistrut channels are stamped with the name "UNISTRUT".
- 2) Max F_p shown is based on P5500WT. Max F_p can be increased for different strut types based on section properties shown on page 4c.1.
- 3) Max allowable force F_p may be limited by the capacities of the brace fitting, channel nut or rod connection, trapeze support, anchorage, or capacity of another component.

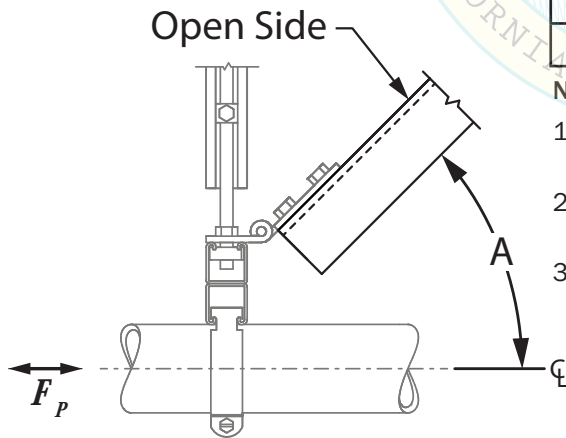

Atkore
Unistrut

16100 S. Lathrop Ave
Harvey, IL 60426
Toll-Free: (800) 882-5543

www.unistrutseismic.com

Rami Elhassan
Structural Engineer: Rami Elhassan
California SE No. 3930

Page:

4a.3

Channel – Rigid Brace

P5501, P5501T, P5501WT, P5501HS - 1 5/8" X 4 7/8" X 12 GA.

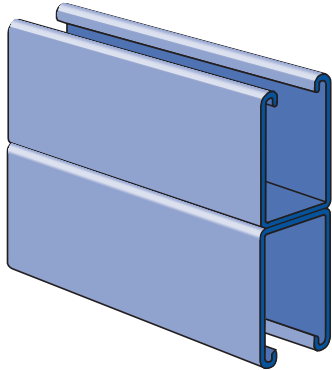

P5501

PIERCED OPTIONS

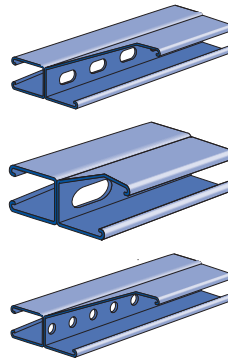

P5501T	9/16" x 1 1/8" Slots 2" on Center
P5501WT	1 1/16" x 2" Slots 3" on Center
P5501HS	9/16" Dia. Holes 1 7/8" on Center

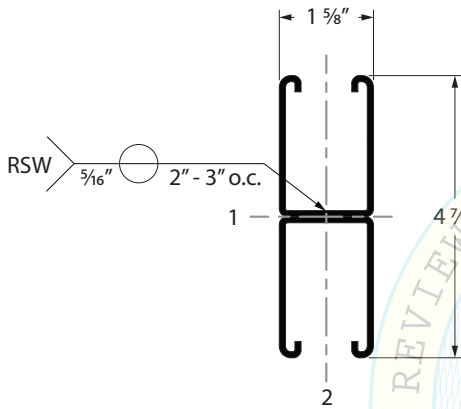

Span (ft.)	Maximum Horizontal F_p Force (lbs) [ASD]			
	Angle "A"			
	0° +5° / -0°	30° +5° / -25°	45° +5° / -10°	60° +0° / -10°
2'	7,160	6,200	5,060	3,580
3'	8,130	7,040	5,740	4,060
4'	7,880	6,820	5,570	3,940
5'	7,550	6,530	5,330	3,770
6'	7,120	6,160	5,030	3,560
7'	6,640	5,750	4,690	3,320
8'	6,040	5,230	4,270	3,020
9'	5,410	4,680	3,820	2,700
10'	4,770	4,130	3,370	2,380
12'	3,730	3,230	2,630	1,860
14'	2,950	2,550	2,080	1,470

Notes:

- 1) These values apply only to Unistrut brand products. Unistrut channels are stamped with the name "UNISTRUT".
- 2) Max F_p shown is based on P5501WT. Max F_p can be increased for different strut types based on section properties shown on page 4c.1.
- 3) Max allowable force F_p may be limited by the capacities of the brace fitting, channel nut or rod connection, trapeze support, anchorage, or capacity of another component.

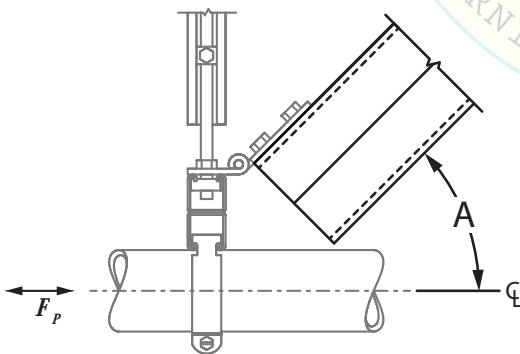

Atkore
Unistrut

16100 S. Lathrop Ave
Harvey, IL 60426
Toll-Free: (800) 882-5543

www.unistrutseismic.com

Rami Elhassan
Structural Engineer: Rami Elhassan
California SE No. 3930

Page:

4a.4

Channel – Rigid Brace

P5000, P5000T, P5000WT, P5000HS - 1 5/8" X 3 1/4" X 12 GA.

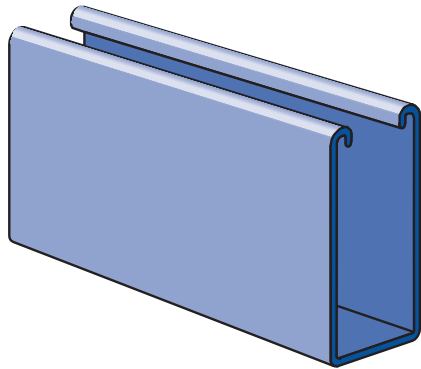

P5000

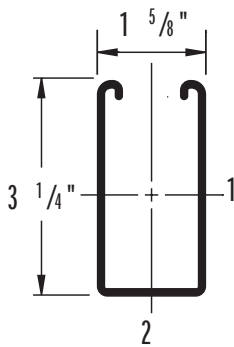

PIERCED OPTIONS

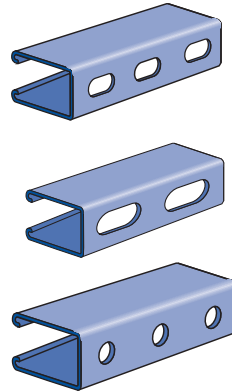

P5000T	9/16" x 1 1/8" Slots 2" on Center
P5000WT	11/16" x 2" Slots 3" on Center
P5000HS	9/16" Dia. Holes 1 7/8" on Center

Span (ft.)	Maximum Horizontal F_p Force (lbs) [ASD]			
	Angle "A"			
	0° +5° / -0°	30° +5° / -25°	45° +5° / -10°	60° +0° / -10°
2'	5,490	4,750	3,880	2,740
3'	4,640	4,010	3,280	2,320
4'	3,560	3,080	2,510	1,780
5'	2,730	2,360	1,930	1,360
6'	2,160	1,870	1,520	1,080
7'	1,760	1,520	1,240	880
8'	1,500	1,290	1,060	750
9'	1,310	1,130	920	650
10'	1,170	1,010	820	580
12'	980	840	690	490
14'	850	730	600	420

Notes:

- 1) These values apply only to Unistrut brand products. Unistrut channels are stamped with the name "UNISTRUT".
- 2) Max F_p shown is based on P5000WT. Max F_p can be increased for different strut types based on section properties shown on page 4c.1.
- 3) Max allowable force F_p may be limited by the capacities of the brace fitting, channel nut or rod connection, trapeze support, anchorage, or capacity of another component.

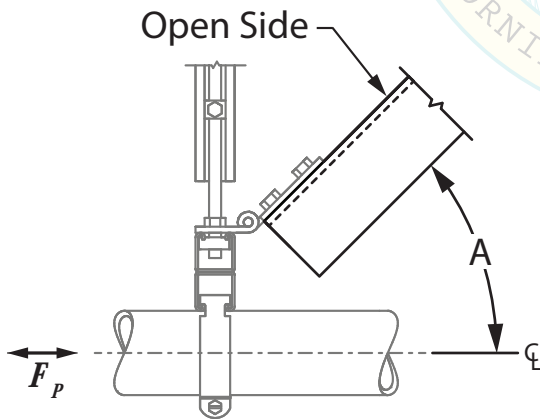

16100 S. Lathrop Ave
Harvey, IL 60426
Toll-Free: (800) 882-5543

www.unistrutseismic.com

Structural Engineer: Rami Elhassan
California SE No. 3930

Page:

4a.5

Channel – Rigid Brace

P5001, P5001T, P5001WT, P5001HS - 1 5/8" X 6 1/2" X 12 GA.

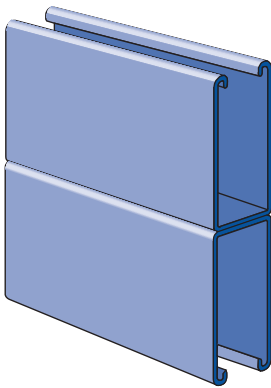

P5001

PIERCED OPTIONS

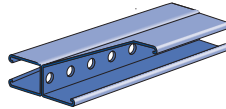
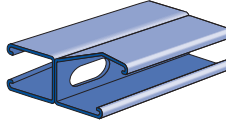
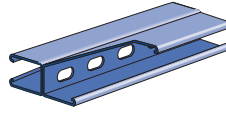

P5001T	1/16" x 1 1/8" Slots 2" on Center
P5001WT	1 1/16" x 2" Slots 3" on Center
P5001HS	1/16" Dia. Holes 1 7/8" on Center

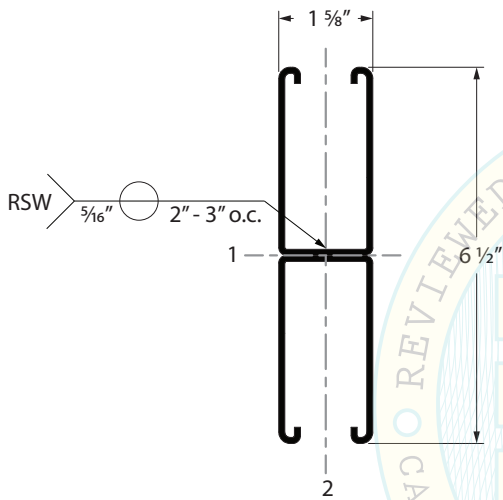

Span (ft.)	Maximum Horizontal F_p Force (lbs) [ASD]			
	Angle "A"			
	0° +5° / -0°	30° +5° / -25°	45° +5° / -10°	60° +0° / -10°
2'	7,160	6,200	5,060	3,580
3'	10,130	8,770	7,160	5,060
4'	9,750	8,440	6,890	4,870
5'	9,140	7,910	6,460	4,570
6'	8,440	7,300	5,960	4,220
7'	7,780	6,730	5,500	3,890
8'	7,160	6,200	5,060	3,580
9'	6,560	5,680	4,630	3,280
10'	5,740	4,970	4,050	2,870
12'	4,370	3,780	3,090	2,180
14'	3,400	2,940	2,400	1,700

Notes:

- 1) These values apply only to Unistrut brand products. Unistrut channels are stamped with the name "UNISTRUT".
- 2) Max F_p shown is based on P5001WT. Max F_p can be increased for different strut types based on section properties shown on page 4c.1.
- 3) Max allowable force F_p may be limited by the capacities of the brace fitting, channel nut or rod connection, trapeze support, anchorage, or capacity of another component.

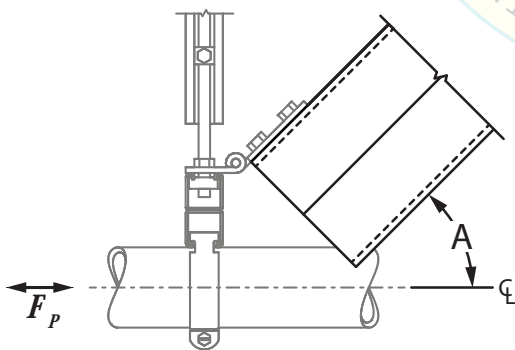

Atkore
Unistrut

16100 S. Lathrop Ave
Harvey, IL 60426
Toll-Free: (800) 882-5543

www.unistrutseismic.com

Rami Elhassan
Structural Engineer: Rami Elhassan
California SE No. 3930

Page:

4a.6

Telespar – Rigid Brace

20F12

2" x 2" x 12 ga

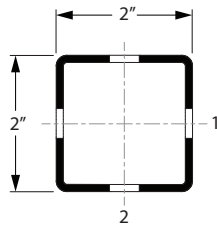
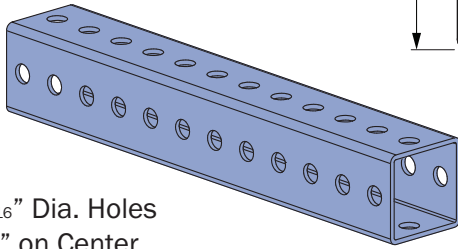

7/16" Dia. Holes
1" on Center

24F12

2 1/2" x 2 1/2" x 12 ga.

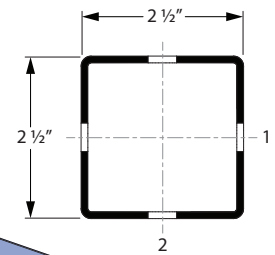
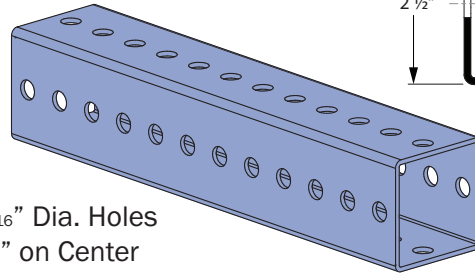

7/16" Dia. Holes
1" on Center

Span (ft.)	Angle "A"			
	0° +5° / -0°	30° +5° / -25°	45° +5° / -10°	60° +0° / -10°
2'	7,860	6,800	5,550	3,930
3'	7,660	6,630	5,410	3,830
4'	7,360	6,370	5,200	3,680
5'	6,980	6,040	4,930	3,490
6'	6,520	5,640	4,610	3,260
7'	5,970	5,170	4,220	2,980
8'	5,350	4,630	3,780	2,670
9'	4,680	4,050	3,300	2,340
10'	4,050	3,500	2,860	2,020
12'	3,100	2,680	2,190	1,550
14'	2,420	2,090	1,710	1,210
16'	1,940	1,680	1,370	970

Span (ft.)	Angle "A"			
	0° +5° / -0°	30° +5° / -25°	45° +5° / -10°	60° +0° / -10°
2'	10,780	9,330	7,620	5,390
3'	10,600	9,170	7,490	5,300
4'	10,350	8,960	7,310	5,170
5'	10,020	8,670	7,080	5,010
6'	9,620	8,330	6,800	4,810
7'	9,140	7,910	6,460	4,570
8'	8,590	7,430	6,070	4,290
9'	7,970	6,900	5,630	3,980
10'	7,300	6,320	5,160	3,650
12'	5,850	5,060	4,130	2,920
14'	4,700	4,070	3,320	2,350
16'	3,820	3,300	2,700	1,910
18'	3,160	2,730	2,230	1,580
20'	2,650	2,290	1,870	1,320

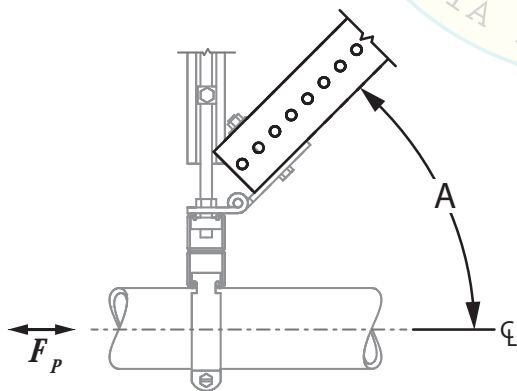

Notes:

- 1) Not to be used in a telescoping manner.
- 2) Max allowable force F_p may be limited by the capacities of the brace fitting, channel nut or rod connection, trapeze support, anchorage, or capacity of another component.

Atkore
Unistrut

16100 S. Lathrop Ave
Harvey, IL 60426
Toll-Free: (800) 882-5543

www.unistrutseismic.com

Rami Elhassan
Structural Engineer: Rami Elhassan
California SE No. 3930

Page:

4a.7

Channel - Beam Loading

PROCEDURE FOR CALCULATING THE BEAM LOAD CAPACITY (G_{ALLOW})

METHOD 1

Step 1: Determine the Maximum Allowable Uniform Load (V_{allow} or D_{allow}) for the selected channel at the span between supports from pages 4b.1 – 4b.6. V_{allow} capacities for Span/180, Span/240 and Span/360 deflection criteria are provided in the tables on pages 4b.1 - 4b.6.

Step 2: Multiply the value from Step 1 by the Unbraced Length Factor (Φ_{LV}). Φ_{LV} can be found on pages 4b.1 – 4b.6.

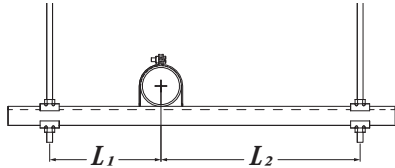

$$L_2 > L_1$$

Use Unbraced Length Factor (Φ_{LV}) for maximum length (L_2 in this scenario)

Step 3: Subtract the channel weight ($W_{channel}$) from the Step 2 value. $W_{channel}$ is found on pages 4b.1 – 4b.6, note 3.

Step 4: Multiply the value from Step 3 by the Load Factor from the table below that matches the loading condition.

Tip: Trapeze supports will typically be condition 1, 2 or 3.

	Load & Support Condition	Load Factor		Load & Support Condition	Load Factor
1		1.00	4		1.30
2		0.50	5		1.00
3		1.00	6		0.62

For Strength Limitation: Beam load capacity (G_{allow}) per Equation 4b.0-1 below

$$\text{Equation (4b.0-1): } G_{allow} = ((V_{allow} * \Phi_{LV}) - W_{channel}) * \text{Load Factor}$$

For Deflection Limitation: Beam load capacity (G_{allow}) is the lesser of Equations 4b.0-1 and 4b.0-2

$$\text{Equation (4b.0-2): } G_{allow} = (D_{allow} - W_{channel}) * \text{Load Factor}$$

METHOD 2

G_{allow} may be calculated using the Allowable Moment M_{allow} and basic beam load calculations. M_{allow} can be found on pages 4b.1 – 4b.6, note 4.

Notes:

- 1) V_{allow} , D_{allow} , M_{allow} and $W_{channel}$ account for “T”, “WT” and “HS” piercings. No additional pierced hole reductions are necessary.
- 2) The above procedure is for bending along the 1-1 axis, when the channel slot is facing up or down. For bending along the 2-2 axis, section properties are provided on page 4c.1.

Atkore
Unistrut

16100 S. Lathrop Ave
Harvey, IL 60426
Toll-Free: (800) 882-5543

www.unistrutseismic.com



Structural Engineer: Rami Elhassan
California SE No. 3930

Page:

4b.0

Channel - Beam Loading

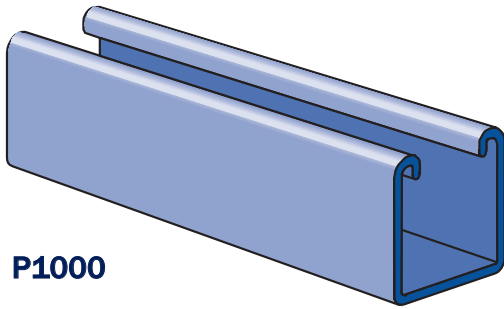
P1000, P1000T, P1000WT, P1000HS - 1 5/8" X 1 5/8" X 12 GA.



P1000

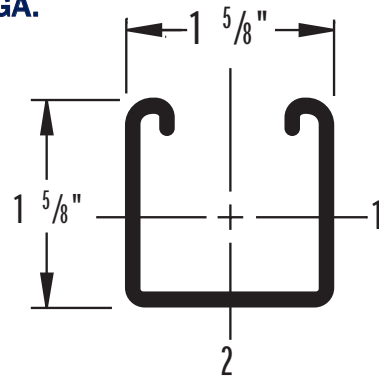

PIERCED OPTIONS

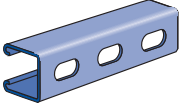
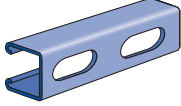
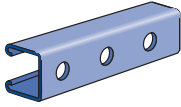
 P1000T	5/16" x 1 1/8" Slots 2" on Center
 P1000WT	1 1/16" x 2" Slots 3" on Center
 P1000HS	9/16" Dia. Holes 1 7/8" on Center

Beam Loads [ASD] Axis 1-1							
Span	Maximum Allowable Uniform Load (V_{allow})	Deflection at Uniform Load	Uniform Loading at Deflection			Unbraced Length	
			Span/180 (D_{allow})	Span/240 (D_{allow})	Span/360 (D_{allow})		
(ft)	(lbs)	(in)	(lbs)	(lbs)	(lbs)	(ft)	Factor (Φ_{LV})
2	1,530	0.06	1,530	1,530	1,530	2	1.00
3	1,020	0.14	1,020	1,020	720	3	0.94
4	760	0.25	760	610	410	4	0.88
5	610	0.39	520	390	260	5	0.82
6	510	0.56	360	270	180	6	0.78
7	440	0.77	270	200	130	7	0.75
8	380	1.00	200	150	100	8	0.71
9	340	1.27	160	120	80	9	0.69
10	310	1.59	130	100	70	10	0.66
12	250	2.21	90	70	50	12	0.61
14	220	3.09	70	50	30	14	0.55
16	190	4.00	50	40	-	16	0.51
18	170	5.08	40	-	-	18	0.47
20	150	6.25	-	-	-	20	0.44

Notes:

- 1) Values in this table apply to P1000, P1000T, P1000WT, and P1000HS channels
- 2) Refer to page 4b.0 for the calculation procedure
- 3) Channel Weight ($W_{channel}$): 1.89 lbs/ft
- 4) Allowable Moment (M_{allow}): 4,575 in-lbs
- 5) Beam loads are provided in total uniform load, not uniform loading (e.g. lbs/ft or lbs/in)
- 6) These values apply only to Unistrut brand products. Unistrut channels are stamped with the name "UNISTRUT".



16100 S. Lathrop Ave
Harvey, IL 60426
Toll-Free: (800) 882-5543

www.unistrutseismic.com

Structural Engineer: Rami Elhassan
California SE No. 3930

Page:

4b.1

Channel - Beam Loading

P1001, P1001T, P1001WT, P1001HS - 1 5/8" X 3 1/4" X 12 GA.

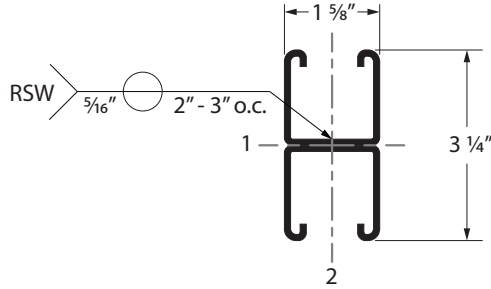
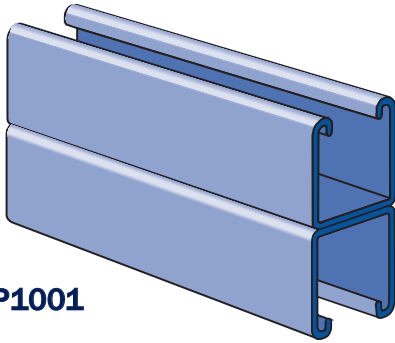

P1001

PIERCED OPTIONS

	<p>1/16" x 1 1/8" Slots 2" on Center</p> <p>P1001T</p>
	<p>1 1/16" x 2" Slots 3" on Center</p> <p>P1001WT</p>
	<p>9/16" Dia. Holes 1 7/8" on Center</p> <p>P1001HS</p>

Beam Loads [ASD] Axis 1-1								
Span	Maximum Allowable Uniform Load (V_{allow})	Deflection at Uniform Load	Uniform Loading at Deflection			Unbraced Length		
			Span/180 (D_{allow})	Span/240 (D_{allow})	Span/360 (D_{allow})			
(ft)	(lbs)	(in)	(lbs)	(lbs)	(lbs)	(ft)	Factor (Φ_{LV})	
2	3,330*	0.02	3,330*	3,330*	3,330*	2	1.00	
3	3,190	0.07	3,190	3,190	3,190	3	1.00	
4	2,390	0.13	2,390	2,390	2,390	4	1.00	
5	1,910	0.20	1,910	1,910	1,620	5	0.97	
6	1,590	0.28	1,590	1,590	1,130	6	0.93	
7	1,370	0.39	1,370	1,240	830	7	0.89	
8	1,200	0.51	1,200	950	630	8	0.85	
9	1,060	0.64	1,000	750	500	9	0.81	
10	960	0.79	810	610	410	10	0.78	
12	800	1.14	560	420	280	12	0.70	
14	680	1.53	410	310	210	14	0.63	
16	600	2.02	320	240	160	16	0.56	
18	530	2.54	250	190	130	18	0.49	
20	480	3.16	200	150	100	20	0.44	

Notes:

- 1) Values in this table apply to P1001, P1001T, P1001WT, and P1001HS channels
- 2) Refer to page 4b.0 for the calculation procedure
- 3) Channel Weight ($W_{channel}$): 3.78 lbs/ft
- 4) Allowable Moment (M_{allow}): 14,345 in-lbs
- 5) Beam loads are provided in total uniform load, not uniform loading (e.g. lbs/ft or lbs/in)
- 6) These values apply only to Unistrut brand products. Unistrut channels are stamped with the name "UNISTRUT".
- 7) * Load limited by spot weld shear. Weld shear and tension are accounted for in the above listed capacities.

<p style="font-size: small; margin-top: 10px;">16100 S. Lathrop Ave Harvey, IL 60426 Toll-Free: (800) 882-5543</p> <p style="font-size: x-small; margin-top: 10px;">www.unistrutseismic.com</p>	<p>Structural Engineer: Rami Elhassan California SE No. 3930</p>	<p>Page:</p> <h2 style="margin: 0;">4b.2</h2>
	<p>Structural Engineer: Rami Elhassan California SE No. 3930</p>	

Channel - Beam Loading

P5500, P5500T, P5500WT, P5500HS - 1 5/8" X 2 7/16" X 12 GA.

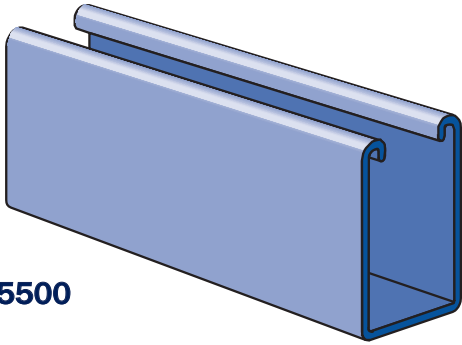

P5500

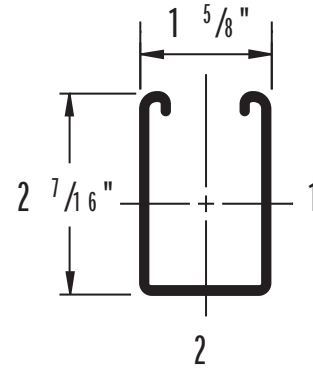

PIERCED OPTIONS

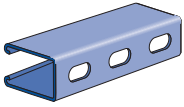
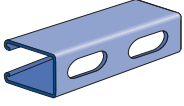
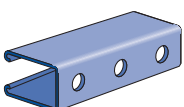
	9/16" x 1 1/8" Slots 2" on Center
P5500T	
	1 1/16" x 2" Slots 3" on Center
P5500WT	
	9/16" Dia. Holes 1 7/8" on Center
P5500HS	

Beam Loads [ASD] Axis 1-1

Span (ft)	Maximum Allowable Uniform Load (V_{allow}) (lbs)	Deflection at Uniform Load (in)	Uniform Loading at Deflection			Unbraced Length	
			Span/180 (D_{allow}) (lbs)	Span/240 (D_{allow}) (lbs)	Span/360 (D_{allow}) (lbs)	(ft)	Factor (Φ_{LV})
2	2,980	0.04	2,980	2,980	2,980	2	0.99
3	1,980	0.09	1,980	1,980	1,980	3	0.89
4	1,490	0.17	1,490	1,490	1,180	4	0.77
5	1,190	0.26	1,190	1,140	760	5	0.67
6	990	0.38	990	790	530	6	0.58
7	850	0.51	770	580	390	7	0.51
8	740	0.67	590	440	300	8	0.46
9	660	0.85	470	350	230	9	0.42
10	600	1.06	380	280	190	10	0.40
12	500	1.52	260	200	130	12	0.36
14	430	2.08	190	140	100	14	0.32
16	370	2.67	150	110	70	16	0.30
18	330	3.39	120	90	60	18	0.28
20	300	4.23	90	70	50	20	0.26

Notes:

- 1) Values in this table apply to P5500, P5500T, P5500WT, and P5500HS channels
- 2) Refer to page 4b.0 for the calculation procedure
- 3) Channel Weight ($W_{channel}$): 2.47 lbs/ft
- 4) Allowable Moment (M_{allow}): 8,925 in-lbs
- 5) Beam loads are provided in total uniform load, not uniform loading (e.g. lbs/ft or lbs/in)
- 6) These values apply only to Unistrut brand products. Unistrut channels are stamped with the name "UNISTRUT".



16100 S. Lathrop Ave
Harvey, IL 60426
Toll-Free: (800) 882-5543

www.unistrutseismic.com

Structural Engineer: Rami Elhassan
California SE No. 3930

Page:

4b.3

Channel - Beam Loading

P5501, P5501T, P5501WT, P5501HS - 1 5/8" X 4 7/8" X 12 GA.

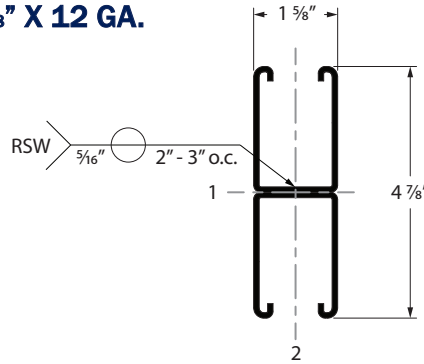
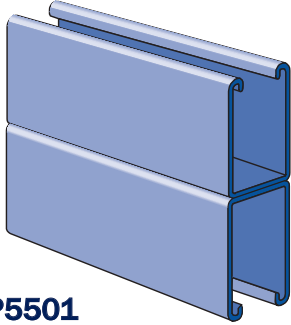

P5501

PIERCED OPTIONS

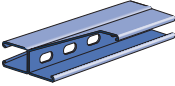
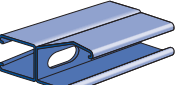
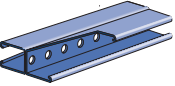
	1/16" x 1 1/8" Slots 2" on Center
	1 1/16" x 2" Slots 3" on Center
	1/16" Dia. Holes 1 7/8" on Center

Beam Loads [ASD] Axis 1-1							
Span (ft)	Maximum Allowable Uniform Load (V_{allow}) (lbs)	Deflection at Uniform Load (in)	Uniform Loading at Deflection			Unbraced Length (ft) Factor (Φ_{LV})	
			Span/180 (D_{allow}) (lbs)	Span/240 (D_{allow}) (lbs)	Span/360 (D_{allow}) (lbs)		
2	5,020*	0.01	5,020*	5,020*	5,020*	2	1.00
3	5,020*	0.04	5,020*	5,020*	5,020*	3	1.00
4	4,820	0.08	4,820	4,820	4,820	4	0.98
5	3,860	0.13	3,860	3,860	3,860	5	0.93
6	3,210	0.19	3,210	3,210	3,210	6	0.87
7	2,760	0.26	2,760	2,760	2,500	7	0.81
8	2,410	0.34	2,410	2,410	1,910	8	0.76
9	2,140	0.42	2,140	2,140	1,510	9	0.70
10	1,930	0.52	1,930	1,840	1,230	10	0.64
12	1,610	0.76	1,610	1,280	850	12	0.53
14	1,380	1.03	1,250	940	630	14	0.45
16	1,210	1.35	960	720	480	16	0.39
18	1,070	1.70	760	570	380	18	0.34
20	960	2.09	610	460	310	20	0.30

Notes:

- 1) Values in this table apply to P5501, P5501T, P5501WT, and P5501HS channels
- 2) Refer to page 4b.0 for the calculation procedure
- 3) Channel Weight ($W_{channel}$): 4.94 lbs/ft
- 4) Allowable Moment (M_{allow}): 28,930 in-lbs
- 5) Beam loads are provided in total uniform load, not uniform loading (e.g. lbs/ft or lbs/in)
- 6) These values apply only to Unistrut brand products. Unistrut channels are stamped with the name "UNISTRUT".
- 7) * Load limited by spot weld shear. Weld shear and tension are accounted for in the above listed capacities.



16100 S. Lathrop Ave
Harvey, IL 60426
Toll-Free: (800) 882-5543

www.unistrutseismic.com



Structural Engineer: Rami Elhassan
California SE No. 3930

Page:

4b.4

Channel - Beam Loading

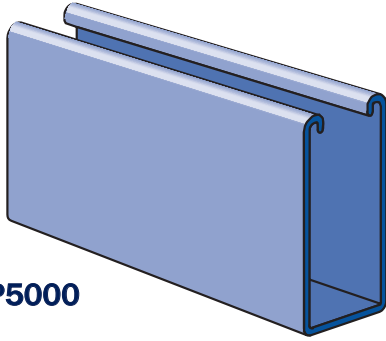
P5000, P5000T, P5000WT, P5000HS - 1 5/8" X 3 1/4" X 12 GA.



P5000

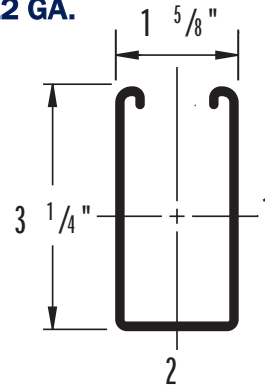

PIERCED OPTIONS

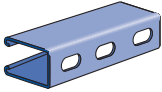
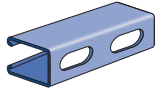
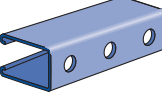
	$\frac{9}{16}$ " x 1 $\frac{1}{8}$ " Slots 2" on Center
P5000T	
	$1\frac{1}{16}$ " x 2" Slots 3" on Center
P5000WT	
	$\frac{9}{16}$ " Dia. Holes 1 $\frac{7}{8}$ " on Center
P5000HS	

Beam Loads [ASD] Axis 1-1							
Span	Maximum Allowable Uniform Load (V_{allow})	Deflection at Uniform Load	Uniform Loading at Deflection			Unbraced Length	
			Span/180 (D_{allow})	Span/240 (D_{allow})	Span/360 (D_{allow})	(ft)	Factor (Φ_{LV})
(ft)	(lbs)	(in)	(lbs)	(lbs)	(lbs)		
2	4,820	0.03	4,820	4,820	4,820	2	0.98
3	3,210	0.07	3,210	3,210	3,210	3	0.85
4	2,410	0.13	2,410	2,410	2,410	4	0.70
5	1,930	0.20	1,930	1,930	1,630	5	0.55
6	1,610	0.28	1,610	1,610	1,130	6	0.44
7	1,380	0.39	1,380	1,250	830	7	0.38
8	1,200	0.50	1,200	960	640	8	0.33
9	1,070	0.64	1,010	760	500	9	0.30
10	960	0.78	820	610	410	10	0.28
12	800	1.13	570	420	280	12	0.24
14	690	1.55	420	310	210	14	0.22
16	600	2.01	320	240	160	16	0.21
18	540	2.57	250	190	130	18	0.19
20	480	3.14	200	150	100	20	0.18

Notes:

- 1) Values in this table apply to P5000, P5000T, P5000WT, and P5000HS channels
- 2) Refer to page 4b.0 for the calculation procedure
- 3) Channel Weight ($W_{channel}$): 3.05 lbs/ft
- 4) Allowable Moment (M_{allow}): 14,450 in-lbs
- 5) Beam loads are provided in total uniform load, not uniform loading (e.g. lbs/ft or lbs/in)
- 6) These values apply only to Unistrut brand products. Unistrut channels are stamped with the name "UNISTRUT".



16100 S. Lathrop Ave
Harvey, IL 60426
Toll-Free: (800) 882-5543

www.unistrutseismic.com

Structural Engineer: Rami Elhassan
California SE No. 3930

Page:

4b.5

Channel - Beam Loading

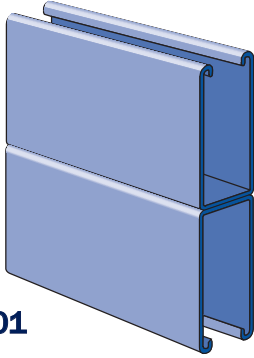

P5001, P5001T, P5001WT, P5001HS - 1 5/8" X 6 1/2" X 12 GA.

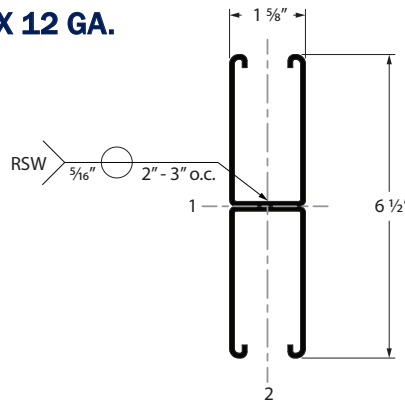

P5001

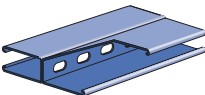

PIERCED OPTIONS

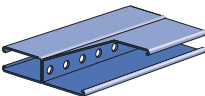
 P5001T	5/16" x 1 1/8" Slots 2" on Center
 P5001WT	1 1/16" x 2" Slots 3" on Center
 P5001HS	5/16" Dia. Holes 1 7/8" on Center

Beam Loads [ASD] Axis 1-1							
Span	Maximum Allowable Uniform Load (V_{allow})	Deflection at Uniform Load	Uniform Loading at Deflection			Unbraced Length	
			Span/180 (D_{allow})	Span/240 (D_{allow})	Span/360 (D_{allow})		
(ft)	(lbs)	(in)	(lbs)	(lbs)	(lbs)	(ft)	Factor (Φ_{LV})
2	5,620*	0.01	5,620*	5,620*	5,620*	2	1.00
3	6,890*	0.02	6,890*	6,890*	6,890*	3	1.00
4	6,890*	0.05	6,890*	6,890*	6,890*	4	0.97
5	6,420	0.10	6,420	6,420	6,420	5	0.90
6	5,350	0.14	5,350	5,350	5,350	6	0.83
7	4,590	0.19	4,590	4,590	4,590	7	0.76
8	4,010	0.25	4,010	4,010	4,010	8	0.68
9	3,570	0.32	3,570	3,570	3,360	9	0.61
10	3,210	0.39	3,210	3,210	2,720	10	0.53
12	2,680	0.57	2,680	2,680	1,890	12	0.42
14	2,290	0.77	2,290	2,080	1,390	14	0.35
16	2,010	1.01	2,010	1,590	1,060	16	0.30
18	1,780	1.27	1,680	1,260	840	18	0.26
20	1,610	1.58	1,360	1,020	680	20	0.24

Notes:

- 1) Values in this table apply to P5001, P5001T, P5001WT, and P5001HS channels
- 2) Refer to page 4b.0 for the calculation procedure
- 3) Channel Weight ($W_{channel}$): 6.10 lbs/ft
- 4) Allowable Moment (M_{allow}): 48,170 in-lbs
- 5) Beam loads are provided in total uniform load, not uniform loading (e.g. lbs/ft or lbs/in)
- 6) These values apply only to Unistrut brand products. Unistrut channels are stamped with the name "UNISTRUT".
- 7) * Load limited by spot weld shear. Weld shear and tension are accounted for in the above listed capacities.



16100 S. Lathrop Ave
Harvey, IL 60426
Toll-Free: (800) 882-5543

www.unistrutseismic.com

Structural Engineer: Rami Elhassan
California SE No. 3930

Page:

4b.6

Channel Section Properties

Minimum Section Properties ¹								
Channel	Area of Section (in ²)	Weight (lbs/ft)	Axis 1-1			Axis 2-2		
			Moment of Inertia (I) (in ⁴)	Section Modulus (S) (in ³)	Radius of Gyration (r) (in.)	Moment of Inertia (I) (in ⁴)	Section Modulus (S) (in ³)	Radius of Gyration (r) (in.)
P1000	0.555	1.89	0.185	0.202	0.577	0.236	0.290	0.651
P1000T	0.496	1.85	0.156	0.186	0.561	0.234	0.288	0.687
P1000HS	0.496	1.85	0.156	0.186	0.561	0.234	0.288	0.687
P1000WT	0.483	1.84	0.149	0.182	0.555	0.233	0.286	0.694
P1001	1.110	3.78	0.928	0.571	0.914	0.471	0.58	0.651
P1001T	0.992	3.70	0.927	0.571	0.967	0.468	0.576	0.687
P1001HS	0.992	3.70	0.927	0.571	0.967	0.468	0.576	0.687
P1001WT	0.966	3.68	0.927	0.571	0.98	0.465	0.573	0.694
P5500	0.726	2.47	0.522	0.390	0.848	0.334	0.411	0.679
P5500T	0.667	2.42	0.451	0.363	0.822	0.333	0.409	0.706
P5500HS	0.667	2.42	0.451	0.363	0.822	0.333	0.409	0.706
P5500WT	0.654	2.41	0.433	0.355	0.814	0.331	0.408	0.712
P5501	1.452	4.94	2.805	1.151	1.39	0.668	0.823	0.679
P5501T	1.334	4.84	2.804	1.150	1.45	0.665	0.819	0.706
P5501HS	1.334	4.84	2.804	1.150	1.45	0.665	0.819	0.706
P5501WT	1.307	4.82	2.804	1.150	1.465	0.663	0.816	0.712
P5000	0.896	3.05	1.098	0.627	1.107	0.433	0.533	0.695
P5000T	0.837	3.00	0.965	0.586	1.074	0.431	0.531	0.718
P5000HS	0.837	3.00	0.965	0.586	1.074	0.431	0.531	0.718
P5000WT	0.824	2.99	0.933	0.575	1.064	0.43	0.529	0.722
P5001	1.793	6.10	6.226	1.916	1.863	0.866	1.066	0.695
P5001T	1.675	6.00	6.225	1.916	1.928	0.863	1.062	0.718
P5001HS	1.675	6.00	6.225	1.916	1.928	0.863	1.062	0.718
P5001WT	1.649	5.98	6.225	1.915	1.943	0.86	1.059	0.722
20F12	0.593	2.42	0.376	0.376	0.796	0.376	0.376	0.796
24F12	0.803	3.14	0.802	0.642	0.999	0.802	0.642	0.999

Notes:

- 1) Minimum section properties are provided, taken through the centerline of any holes or piercings.
- 2) These values apply only to Unistrut brand channels. All Unistrut channels are stamped with the name "UNISTRUT".



16100 S. Lathrop Ave
Harvey, IL 60426
Toll-Free: (800) 882-5543

www.unistrutseismic.com

Structural Engineer: Rami Elhassan
California SE No. 3930

Page:

4c.1

Components: Fittings, Pipe & Conduit Clamps and Wolf Washer

WOLF WASHER

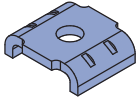
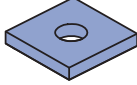
PART NUMBERS		PAGE
	P3892-XX	5b.1 5b.2
	P1063 P1964 P1064 P2471	5b.1

PIPE, CONDUIT & TUBE CLAMPS

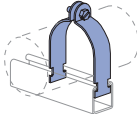
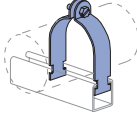
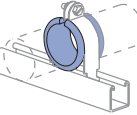
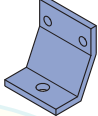
PART NUMBERS		PAGE
	P1100 Series for Pipe & RMC	5d.1
	P1400 Series P1100 Series for EMT & IMC	5d.2
	P1400 Series, P2000 Series & P2600 for Copper Pipe & Tube	5d.3
	9132R, 9132S for Cable Tray	5e.1

BRACE FITTINGS

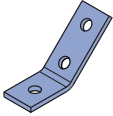
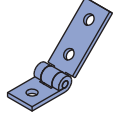
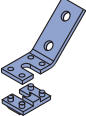
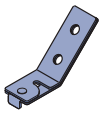
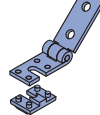
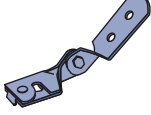
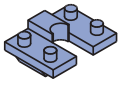
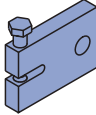
PART NUMBERS		PAGE
	P3810-050 P3815-050	5c.1
	P1354AW P3835-050	5c.1
	P3820-050 P3825-050 P3860	5c.2
	SPF 100-XXX	5c.2
	P3840-050 P3845-050 P3860	5c.3
	SPF 200-XXX	5c.3
	P3860 LS 100 LS 200	5c.4
	P3880	5c.5

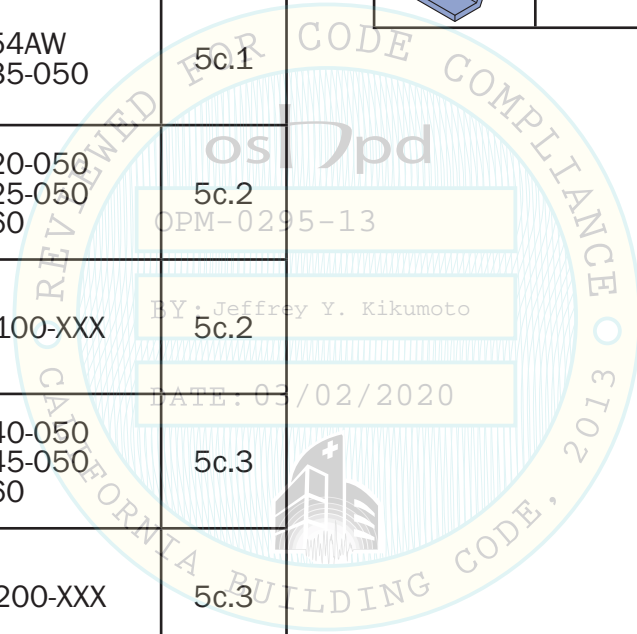

16100 S. Lathrop Ave
Harvey, IL 60426
Toll-Free: (800) 882-5543

www.unistrutseismic.com

Rami Elhassan

Structural Engineer: Rami Elhassan
California SE No. 3930

Page:

5a.0

Typical Connection Details

DETAIL 5A.1-1: TYPICAL FITTING CONNECTION TO STRUT

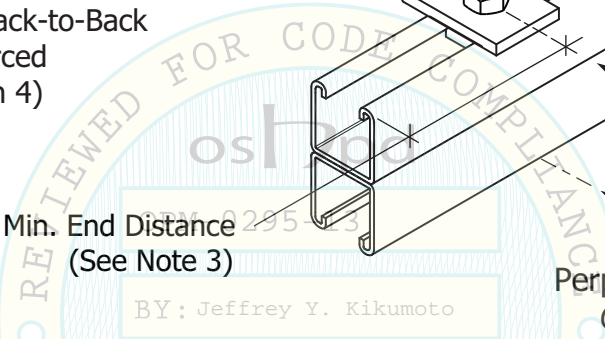
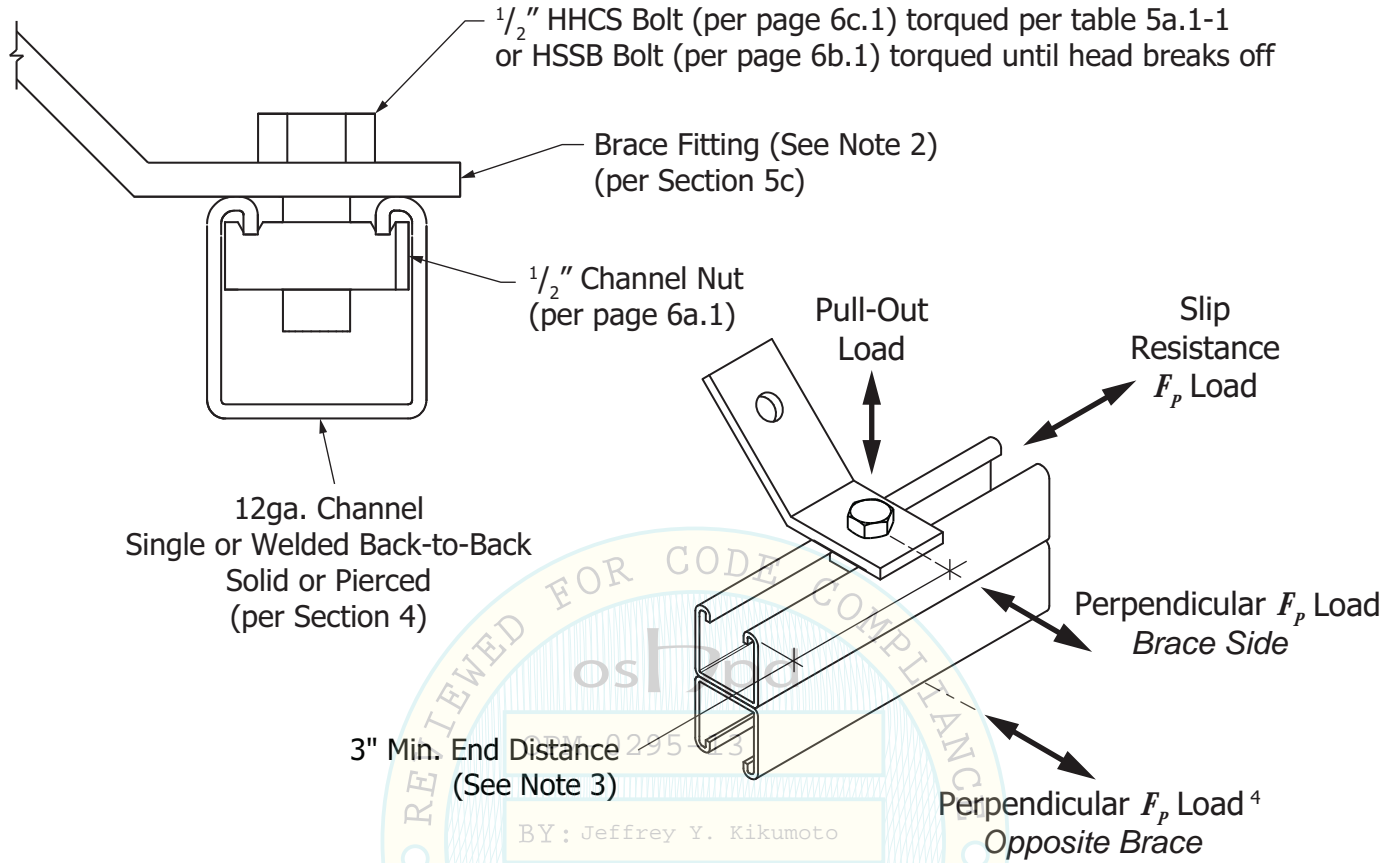

Bolt Size	Installation Torque (ft-lbs)	Maximum Horizontal F_p Force (lbs) [ASD]			
		Max. Capacity (lbs) [ASD] Pull-Out	Slip Resistance	Perpendicular Brace Side	Perpendicular ⁴ Opposite Brace
1/2"	50 - 55	2,810	1,370	1,035	640

Notes:

- 1) Capacities listed in Table 5a.1-1 are for this connection only when attached to the open side of the channel. Fittings, Channel and other component capacities must also be considered.
- 2) The fitting may be oriented in a transverse or longitudinal (as shown) orientation. A typical transverse connection is shown on Detail 5b.2-3. A max of two fittings may also be stacked at this connection to accommodate braces in both directions.
- 3) For end distances less than 3", use the Wolf Washer per Page 5a.2.
- 4) When used with P1001, P5501 or P5001 channel and a perpendicular load is applied on the opposite side of the channel from the brace. The total of the perpendicular loads at the Brace Side and Opposite Side must not exceed 1,035 lbs.

Atkore
Unistrut

16100 S. Lathrop Ave
Harvey, IL 60426
Toll-Free: (800) 882-5543

www.unistrutseismic.com

Rami Elhassan

Structural Engineer: Rami Elhassan
California SE No. 3930

Page:

5a.1

Typical Connection Details

DETAIL 5A.2-1: TYPICAL FITTING CONNECTION TO STRUT WITH WOLF WASHER

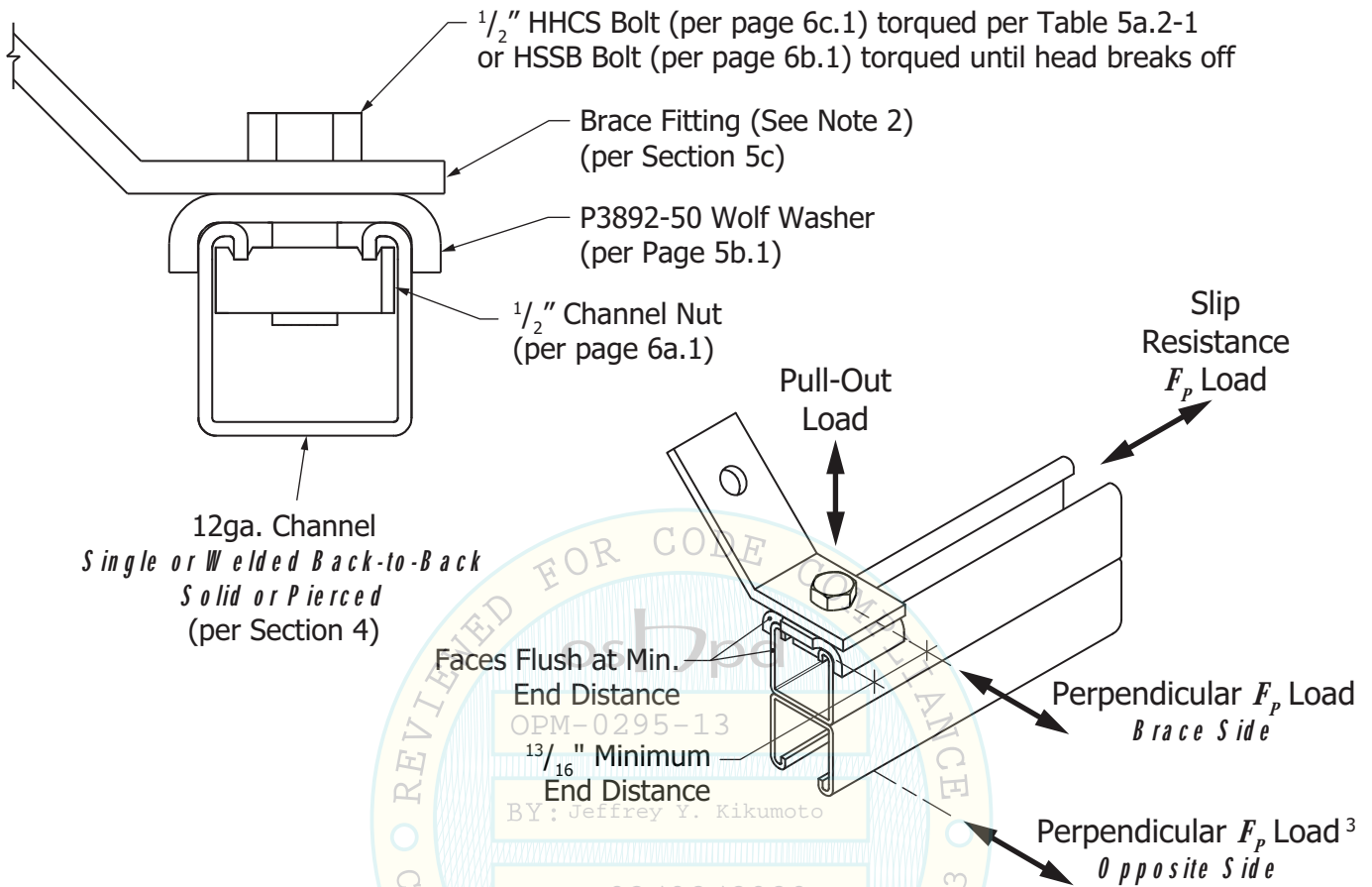

Table 5a.2-1

Bolt Size	Installation Torque (ft-lbs)	Maximum Horizontal F_p Force (lbs) [ASD]			
		Max. Capacity (lbs) [ASD]	Slip Resistance	Perpendicular Brace Side	Perpendicular ³ Opposite Brace
1/2"	60 - 65	2,605	2,375	935	640

Notes:

- 1) Capacities listed in Table 5a.2-1 are for this connection only when attached to the open side of the Channel. Fittings, Channel and other component capacities must also be considered.
- 2) The fitting may be oriented in a transverse or longitudinal (as shown) orientation. A typical transverse connection is shown on Detail 5b.2-3. A max of two fittings may also be stacked at this connection to accommodate braces in both directions.
- 3) When used with P1001, P5501 or P5001 channel and a perpendicular load is applied on the opposite side of the channel from the brace. The total of the perpendicular loads at the Brace Side and Opposite Side must not exceed 935 lbs.

Atkore™

Unistrut

16100 S. Lathrop Ave
 Harvey, IL 60426
 Toll-Free: (800) 882-5543

www.unistrutseismic.com

Rami Elhassan

Structural Engineer: Rami Elhassan
 California SE No. 3930

Page:

5a.2

Typical Connection Details

DETAIL 5A.3-1: TYPICAL THREADED ROD CONNECTION TO STRUT WITH BRACE

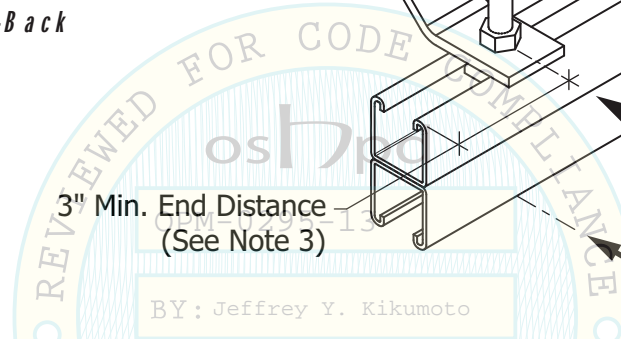
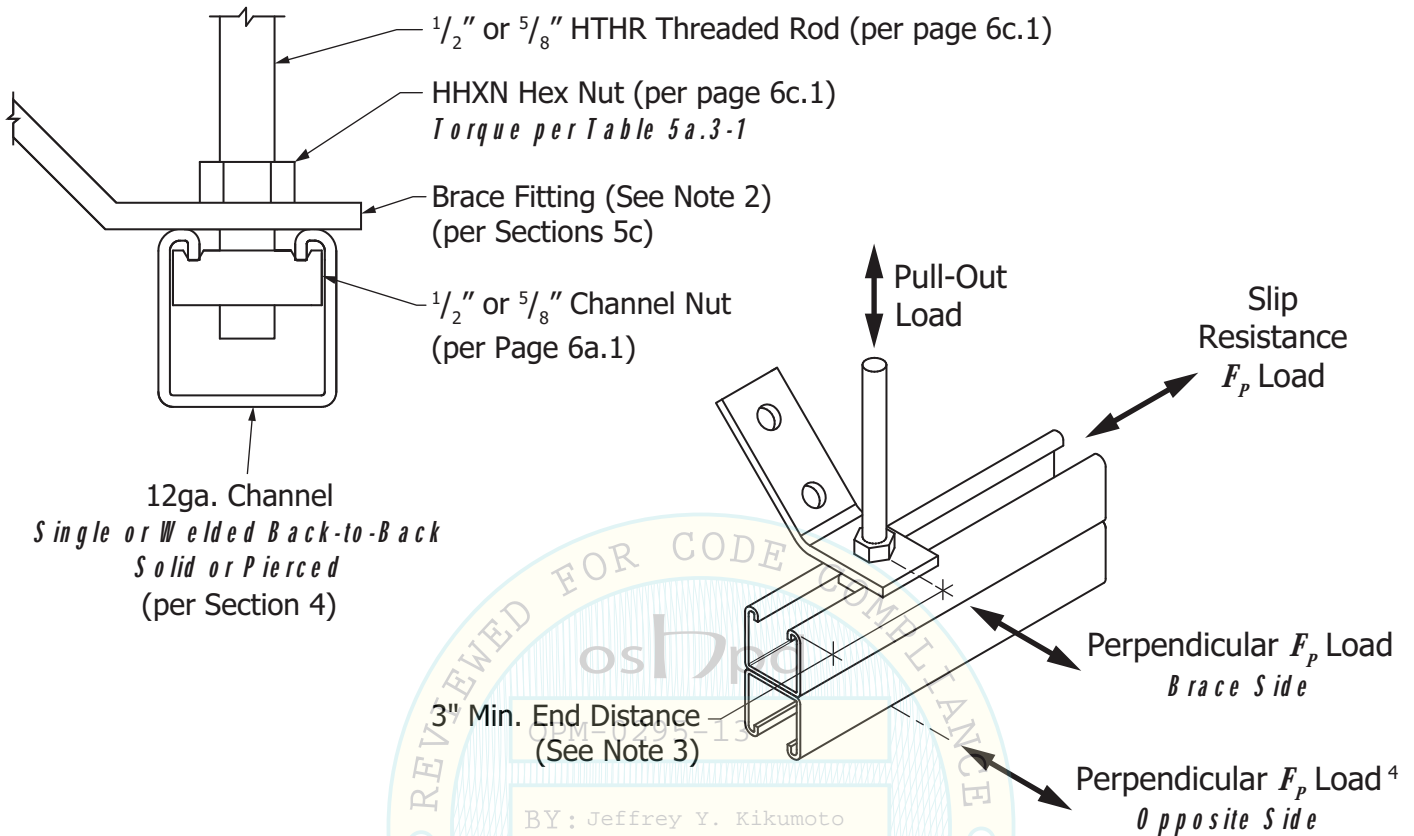

Rod Size	Installation Torque (ft-lbs)	Maximum Horizontal F_p Force (lbs) [ASD]			
		Max. Capacity (lbs) [ASD] Pull-Out	Slip Resistance	Perpendicular Brace Side	Perpendicular ⁴ Opposite Brace
1/2"	50 - 55	2,810	1,370	1,035	640
5/8"	100 - 110	2,810	1,370	1,035	640

Notes:

- 1) Capacities listed in Table 5a.3-1 are for this connection only when attached to the open side of the channel. Fittings, Channel and other component capacities must also be considered.
- 2) The fitting may be oriented in a transverse or longitudinal (as shown) orientation. A typical transverse connection is shown on Detail 5b.2-3. A max of two fittings may also be stacked at this connection to accommodate braces in both directions.
- 3) For end distances less than 3", use the Wolf Washer per Page 5a.4.
- 4) When used with P1001, P5501 or P5001 channel and a perpendicular load is applied on the opposite side of the channel from the brace. The total of the perpendicular loads at the Brace Side and Opposite Side must not exceed 1,035 lbs.



16100 S. Lathrop Ave
Harvey, IL 60426
Toll-Free: (800) 882-5543

www.unistrutseismic.com

Structural Engineer: Rami Elhassan
California SE No. 3930

Page:

5a.3

Typical Connection Details

DETAIL 5A.4-1: TYPICAL THREADED ROD CONNECTION TO STRUT WITH WOLF WASHER AND BRACE

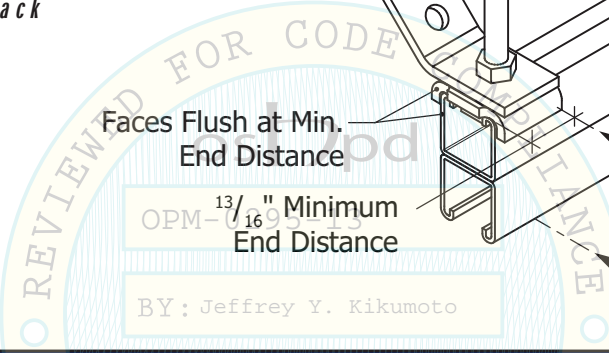
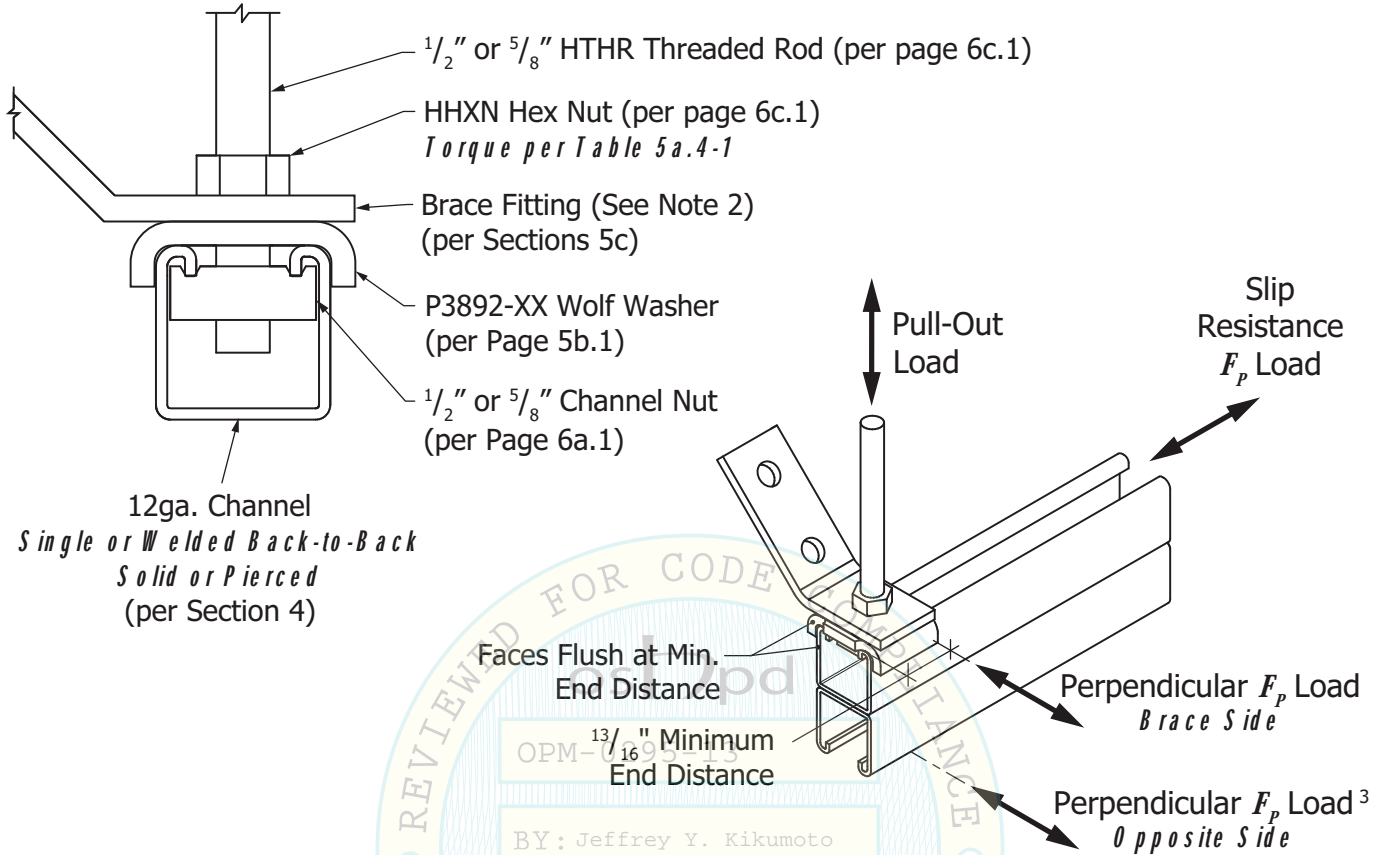

Table 5a.4-1

Rod Size	Installation Torque (ft-lbs)	Maximum Horizontal F_p Force (lbs) [ASD]			
		Max. Capacity (lbs) [ASD] Pull-Out	Slip Resistance	Perpendicular Brace Side	Perpendicular ⁴ Opposite Brace
1/2"	60 - 65	2,605	2,375	935	640
5/8"	100 - 110	2,605	2,375	935	640

Notes:

- Capacities listed in Table 5a.4-1 are for this connection only when attached to the open side of the Channel. Fittings, Channel and other component capacities must also be considered.
- The fitting may be oriented in a transverse or longitudinal (as shown) orientation. A typical transverse connection is shown on Detail 5b.2-3. A max of two fittings may also be stacked at this connection to accommodate braces in both directions.
- When used with P1001, P5501 or P5001 channel and a perpendicular load is applied on the opposite side of the channel from the brace. The total of the perpendicular loads at the Brace Side and Opposite Side must not exceed 935 lbs.

Atkore™
Unistrut

16100 S. Lathrop Ave
Harvey, IL 60426
Toll-Free: (800) 882-5543

www.unistrutseismic.com

Rami Elhassan

Structural Engineer: Rami Elhassan
California SE No. 3930

Page:

5a.4

Typical Connection Details

DETAIL 5A.5-1: TYPICAL THREADED ROD CONNECTION TO STRUT WITH BRACE

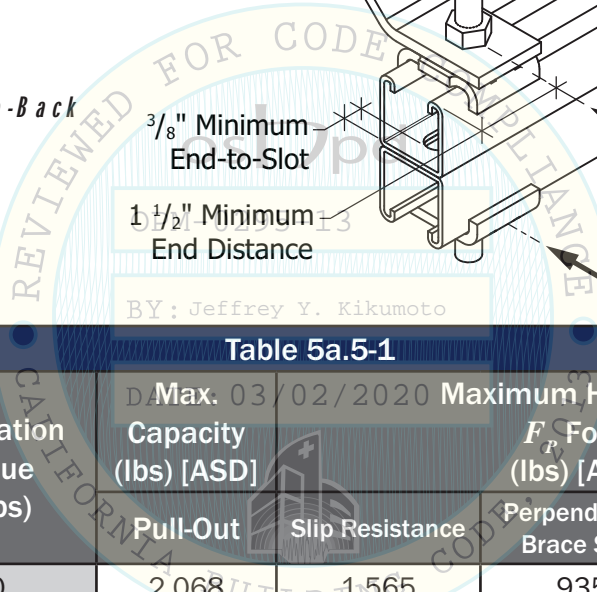
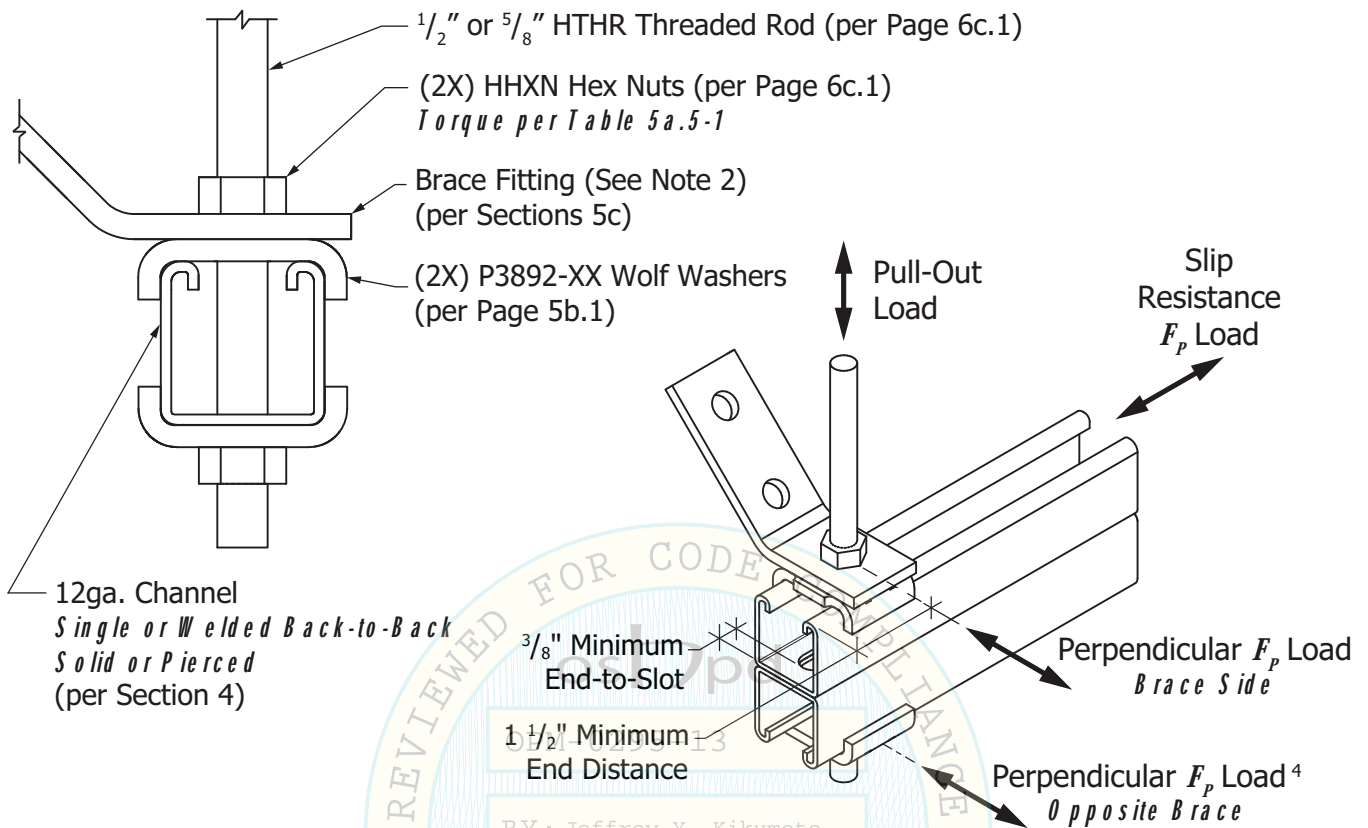

Table 5a.5-1

Rod Size	Installation Torque (ft-lbs)	Maximum Horizontal F_p Force (lbs) [ASD]			
		Pull-Out	Slip Resistance	Perpendicular Brace Side	Perpendicular ⁴ Opposite Brace
1/2"	60	2,068	1,565	935	640
5/8"	73	2,605	1,565	935	640

Notes:

- 1) Capacities listed in Table 5a.5-1 are for this connection only with the brace attached to the open side of the channel. Fittings, Channel and other component capacities must also be considered.
- 2) The fitting may be oriented in a transverse or longitudinal (as shown) orientation. A typical transverse connection is shown on Detail 5b.2-1. A max of two fittings may also be stacked at this connection to accommodate braces in both directions.
- 3) Refer to Section 6D for Rod Stiffening.
- 4) When used with P1001, P5501 or P5001 channel and a perpendicular load is applied on the opposite side of the channel from the brace. The total of the perpendicular loads at the Brace Side and Opposite Side must not exceed 935 lbs.



16100 S. Lathrop Ave
Harvey, IL 60426
Toll-Free: (800) 882-5543

www.unistrutseismic.com

Structural Engineer: Rami Elhassan
California SE No. 3930

Page:

5a.5

Typical Connection Details

DETAIL 5A.6-1: TYPICAL THREADED ROD CONNECTION TO STRUT ADJACENT TO BRACE

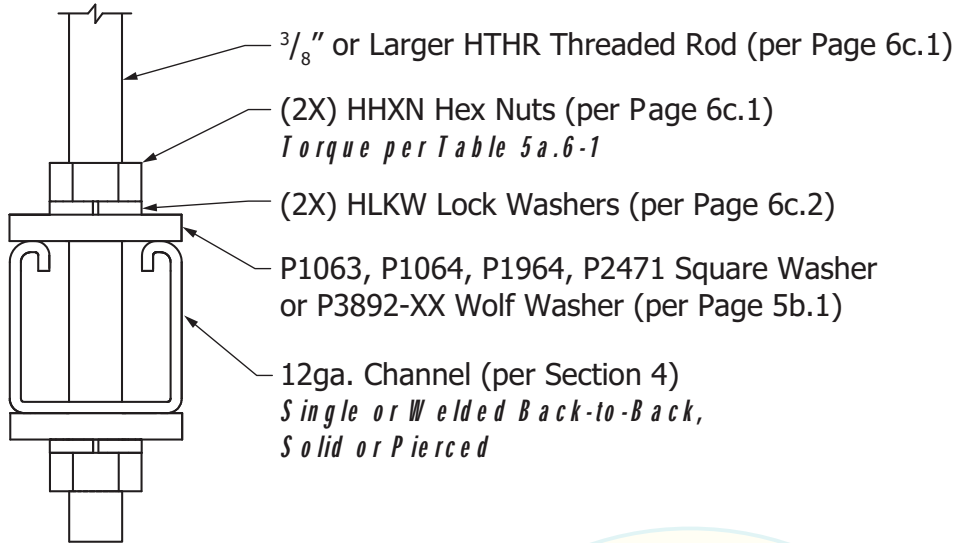

Threaded Rod Size	Hex Nut Torque (ft-lbs)		Maximum Vertical Capacity (lbs) [ASD]
	Min	Max	
3/8"	5	20	815
1/2"		26	2,068
5/8"		33	2,810

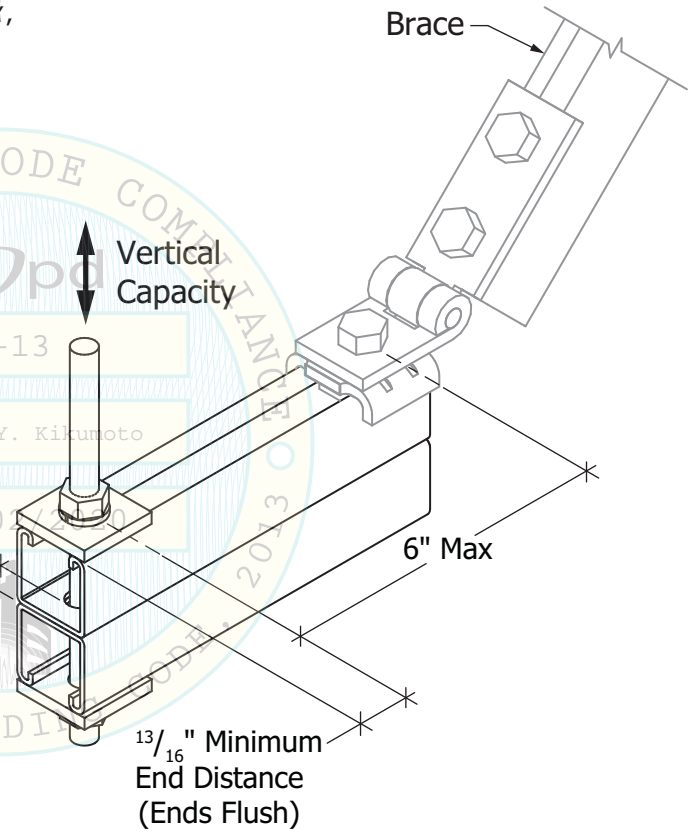

Notes:

- 1) Capacities listed in Table 5a.6-1 are for this connection only. Fittings, Channel and other component capacities must also be considered.
- 2) Refer to Section 6D for Rod Stiffening.
- 3) This connection only has a vertical capacity (as shown). There are no load capacities in the horizontal plane and this connection cannot be used as a seismic brace connection. This is intended for use adjacent to a seismic brace connection. For seismic brace connections, refer to pages 5a.1 thru 5a.5 and 5a.8.



16100 S. Lathrop Ave
Harvey, IL 60426
Toll-Free: (800) 882-5543

www.unistrutseismic.com

Rami Elhassan
Structural Engineer: Rami Elhassan
California SE No. 3930

Page:

5a.6

Typical Connection Details

DETAIL 5A.7-1: TYPICAL THREADED ROD CONNECTION TO STRUT ADJACENT TO BRACE

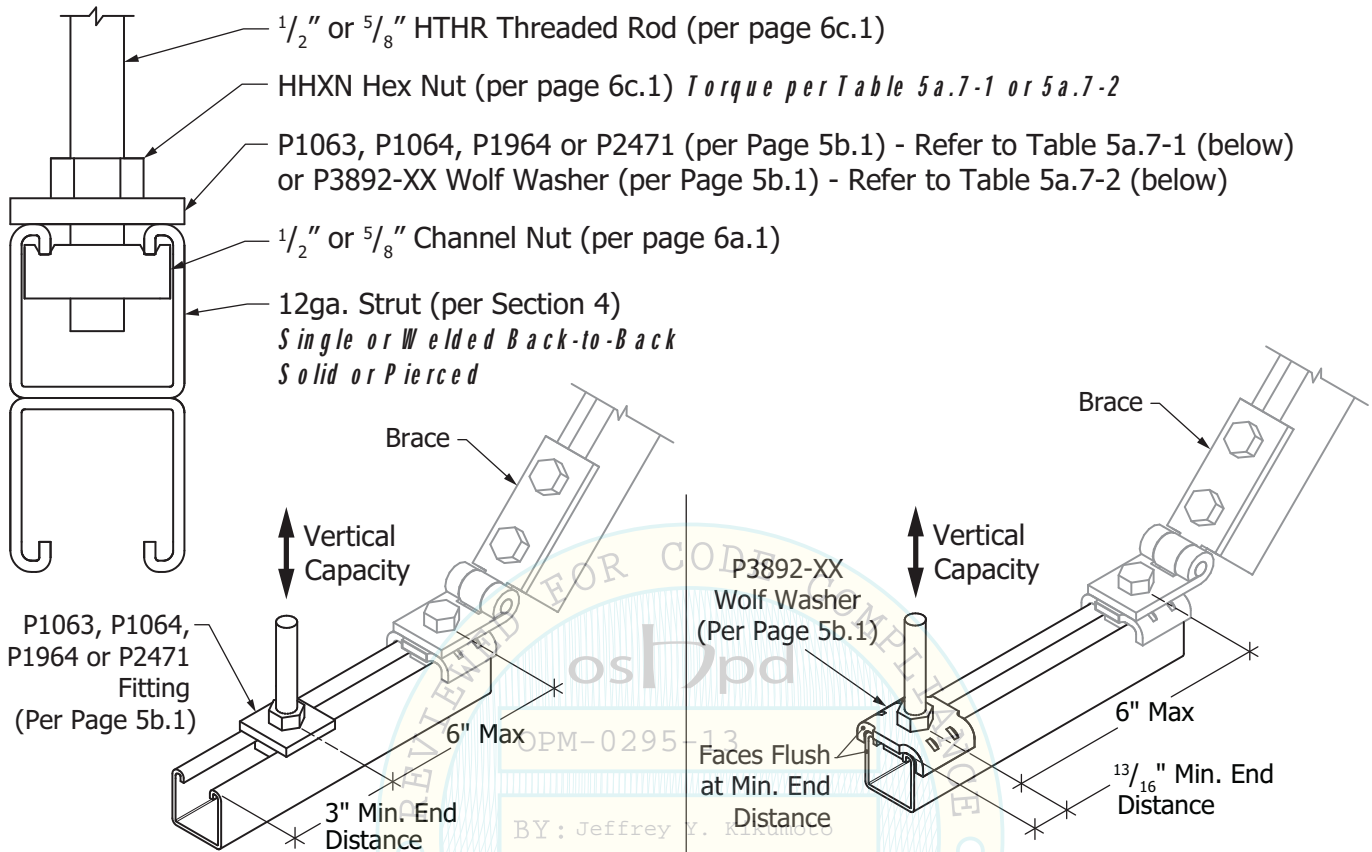

Threaded Rod Size	Hex Nut Torque (ft-lbs)	Maximum Vertical Capacity (lbs) [ASD]
1/2"	50 - 55	2,065
5/8"	100 - 110	2,810

Threaded Rod Size	Hex Nut Torque (ft-lbs)	Maximum Vertical Capacity (lbs) [ASD]
1/2"	60 - 65	2,065
5/8"	100 - 110	2,605

Notes:

- Capacities listed in Tables 5a.7-1 and 5a.7-2 are for this connection only when attached to the open side of the channel. Fittings, Channel and other component capacities must also be considered.
- Refer to Section 6D for Rod Stiffening.
- This connection only has a vertical capacity (as shown). There are no load capacities in the horizontal plane and this connection cannot be used as a seismic brace connection. This is intended for use adjacent to a seismic brace connection. For seismic brace connections, refer to pages 5a.1 thru 5a.5 and 5a.8.

Atkore
Unistrut

16100 S. Lathrop Ave
Harvey, IL 60426
Toll-Free: (800) 882-5543

www.unistrutseismic.com

Rami Elhassan
Structural Engineer: Rami Elhassan
California SE No. 3930

Page:

5a.7

Typical Connection Details

DETAIL 5A.8-1: TYPICAL FITTING CONNECTION TO TELES PAR BRACE WITH 3/8" BOLT

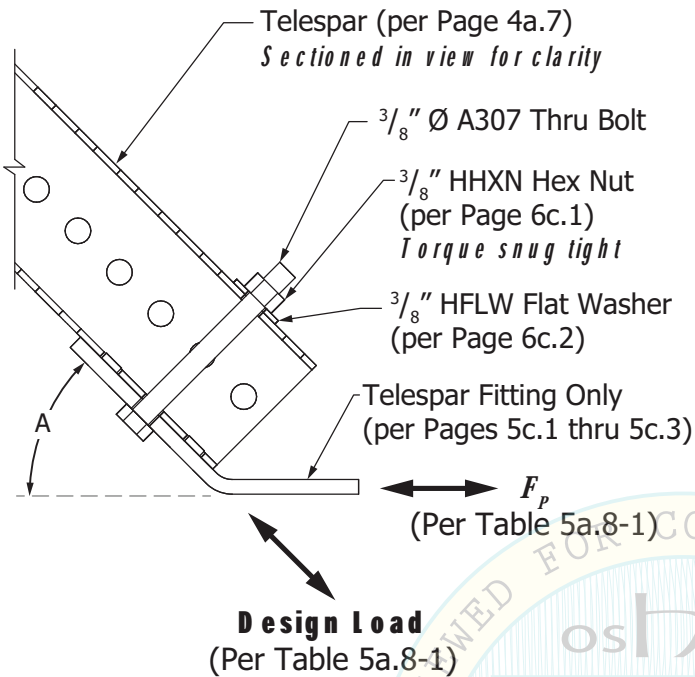

DETAIL 5A.8-2: TYPICAL FITTING CONNECTION TO TELES PAR BRACE WITH 1/2" BOLT

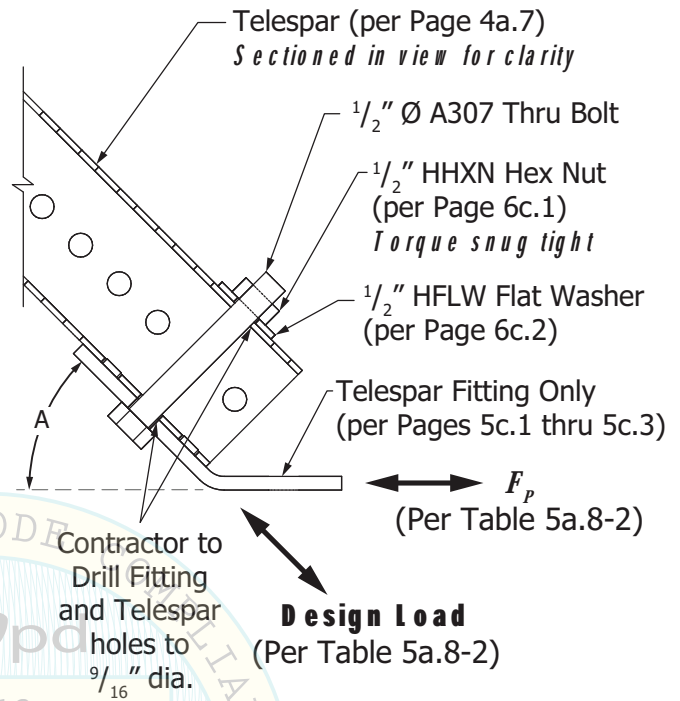

Angle (A) from Horizontal	Design Load (lbs) [ASD]	Maximum Horizontal Force F_p (lbs) [ASD]
30° +5° / -25°	1,325	1,147
45° +5° / -10°	1,325	937
60° +0° / -10°	1,325	662

Angle (A) from Horizontal	Design Load (lbs) [ASD]	Maximum Horizontal Force F_p (lbs) [ASD]
30° +5° / -25°	2,136	1,850
45° +5° / -10°	1,397	985
60° +0° / -10°	1,462	730

Notes:

- Capacities listed in Tables 5a.8-1 and 5a.8-2 are for this connection only. Fittings, Telespar and other component capacities must also be considered.

Atkore
Unistrut

16100 S. Lathrop Ave
Harvey, IL 60426
Toll-Free: (800) 882-5543

www.unistrutseismic.com

Structural Engineer: Rami Elhassan
California SE No. 3930

Page:

5a.8

Wolf Washer & Square Washer

P3892-XX - WOLF WASHER

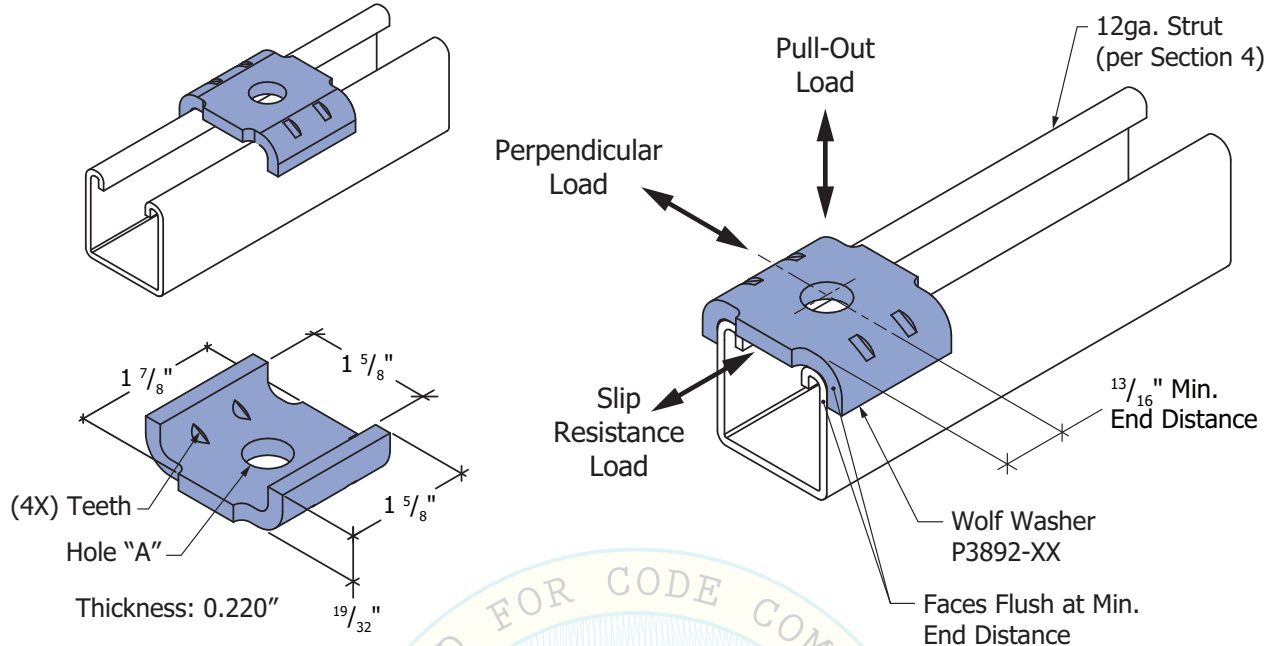

Part No.	Rod Size	Hole Size "A" (Dia.)
P3892-50	1/2"	9/16"
P3892-63	5/8"	1 1/16"

Material / Finish Specifications
Material: ASTM A1011 SS Grade 45
Finish: ASTM B633 Type III SC1 (EG)
Case Hardened

P1063, P1064, P1964, P2471 - SQUARE WASHERS

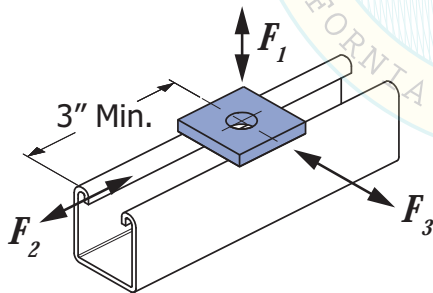

Part No.	Bolt Size	Hole Size
P1063	3/8"	7/16"
P1064	1/2"	9/16"
P1964	5/8"	1 1/16"
P2471	3/4"	1 3/16"

Notes:

- 1) Channel Nut, Fitting and Cap Screw not shown for clarity. See Section 5a and Page 5b.2 for full installation requirements and load capacities.

Atkore
Unistrut

16100 S. Lathrop Ave
Harvey, IL 60426
Toll-Free: (800) 882-5543

www.unistrutseismic.com

Rami Elhassan

Structural Engineer: Rami Elhassan
California SE No. 3930

Page:

5b.1

Wolf Washer

WOLF WASHER (P3892-XX) – CAPACITIES AND INSTALLATION DETAILS

DETAIL 5B.2-1

SLOT ADAPTER FOR TRAPEZE

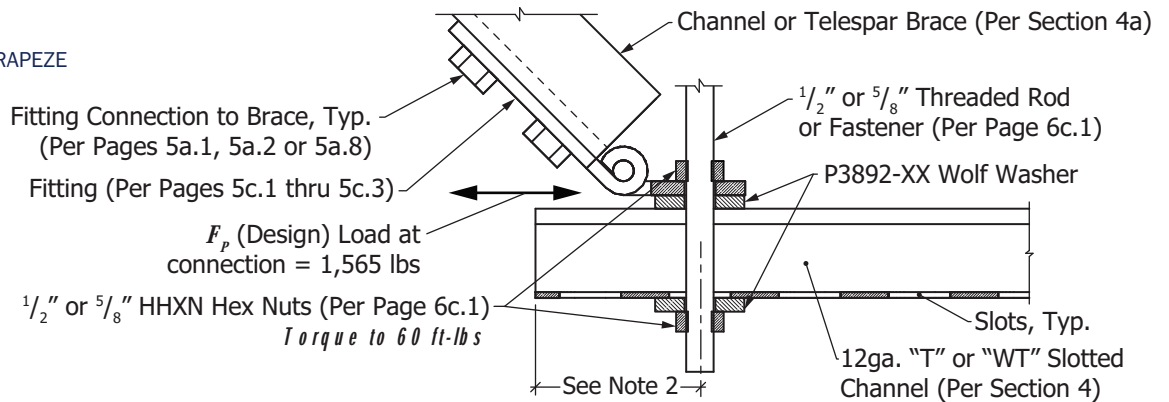

Notes:

- 1) Brace transverse to Channel attached through Wolf Washer has an $F_p = 935$ lbs.
- 2) Min. end distance to be $2\frac{1}{2}$ " for P1000 & P1001, $3\frac{3}{4}$ " for P5500 & P5501, and 5" for P5000 and P5001.

DETAIL 5B.2-2

SLOT ADAPTER FOR ANCHORAGE

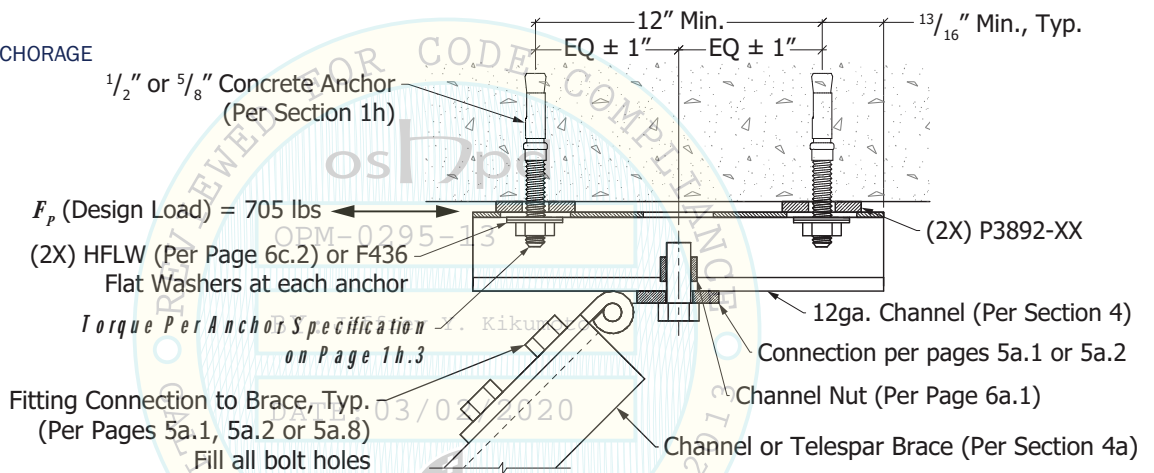

Notes:

- 1) Brace transverse to Channel centered between anchors has an $F_p = 935$ lbs.
- 2) Capacities listed exclude the Concrete Anchor capacity. RDP is responsible for determining the limiting factor.

DETAIL 5B.2-3

INCREASED SLIP RESISTANCE
ATTACHMENT AT END OF STRUT

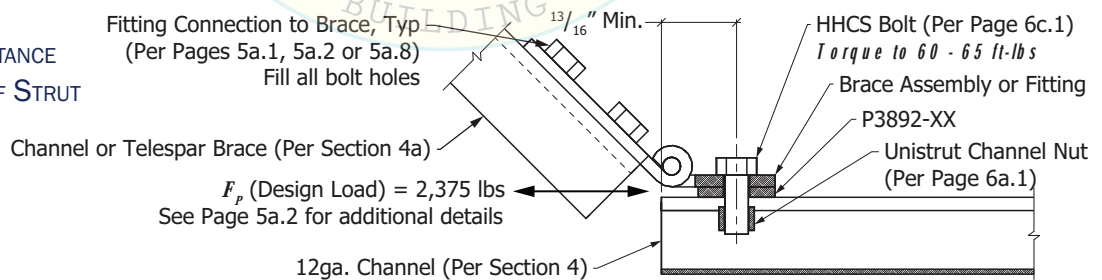

Notes:

- 1) Brace transverse to Channel attached through Wolf Washer has an $F_p = 935$ lbs.
- 2) See Page 5a.2 for additional details.



16100 S. Lathrop Ave
Harvey, IL 60426
Toll-Free: (800) 882-5543

www.unistrutseismic.com

Rami Elhassan
Structural Engineer: Rami Elhassan
California SE No. 3930

Page:

5b.2

Brace Fittings

BRACE FITTINGS – NEW INSTALLATIONS

45° FIXED ANGLE FITTINGS

Material / Finish Specifications All Fittings on this Page
Material: ASTM A1011 SS GR 33 min. or ASTM A1011 HSLAS GR 45 min.
Finish: ASTM B633 Type III SC1 (EG)

P3810-050

FOR STRUT BRACE

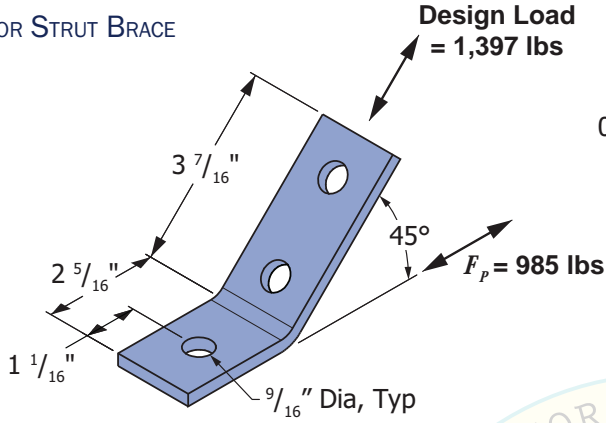

P3815-050

FOR TELES PAR BRACE

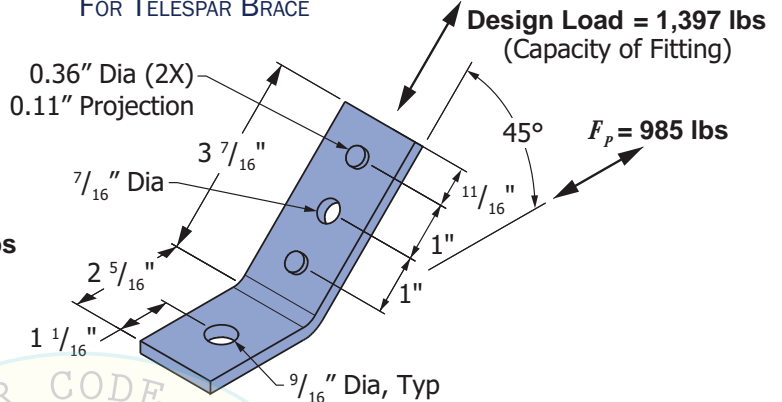

HINGED FITTINGS

P1354AW

FOR STRUT BRACE

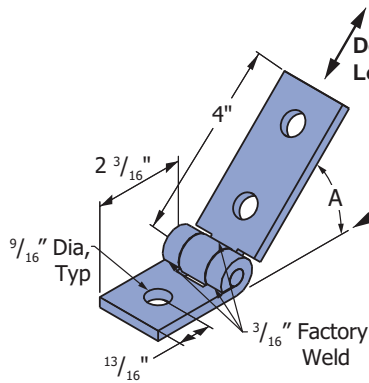

P3835-050

FOR TELES PAR BRACE

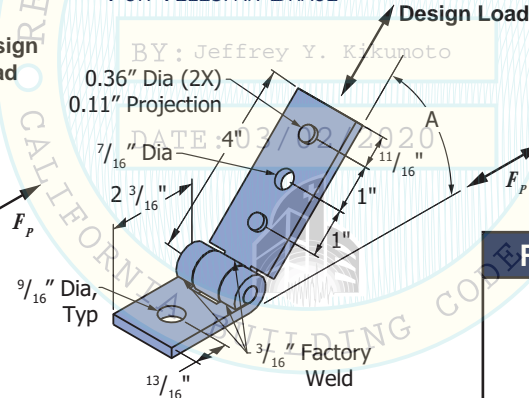

Fittings: P1354AW, P3835-050		
Angle "A" from Horizontal	Design Load (lbs)	F _p (lbs)
30° +5° / -25°	2,136	1,850
45° +5° / -10°	1,397	985
60° +0° / -10°	1,462	730

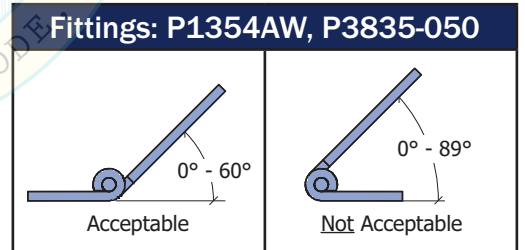

Note:

- 1) Loads based on 1/2" HHCS or HSSB Bolt, and 1/2" Channel Nut.
- 2) All fitting connections to strut must conform to one of the details in Section 5a. All holes in each fitting must have one of these connections unless otherwise noted in the above details. Other components are hidden on this page for clarity.
- 3) Fitting dimensions (all this page) unless otherwise noted: Hole Diameter: 9/16"; Hole Spacing - From End: 13/16"; Hole Spacing - On Center: 1 7/8"; Width: 1 5/8"; Thickness: 1/4" or 0.22".
- 4) P3815-050 and P3835-050 are to be connected to Telespar per Page 5a.8 and capacities on that page may govern.



16100 S. Lathrop Ave
 Harvey, IL 60426
 Toll-Free: (800) 882-5543

www.unistrutseismic.com

Rami Elhassan

Structural Engineer: Rami Elhassan
 California SE No. 3930

Page:

5c.1

Brace Fittings

BRACE FITTINGS – RETROFIT, 45° FIXED ANGLE

P3820-050 + P3860

FOR STRUT BRACE

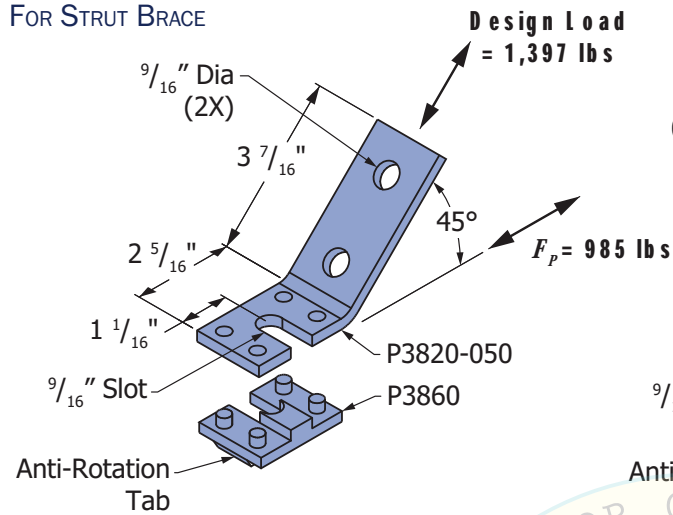

P3825-050 + P3860

FOR TELESAR BRACE

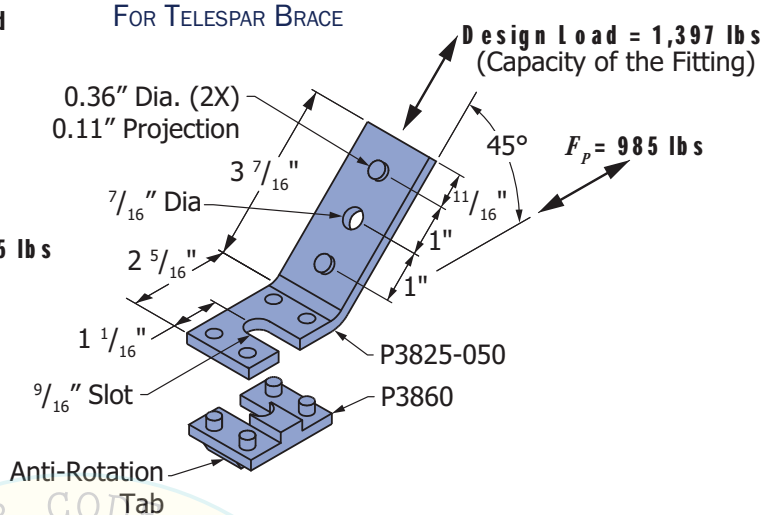

SPF 100-XXX + LS 100

FOR STRUT BRACE

ROD SIZES 1/2" THRU 3/4"

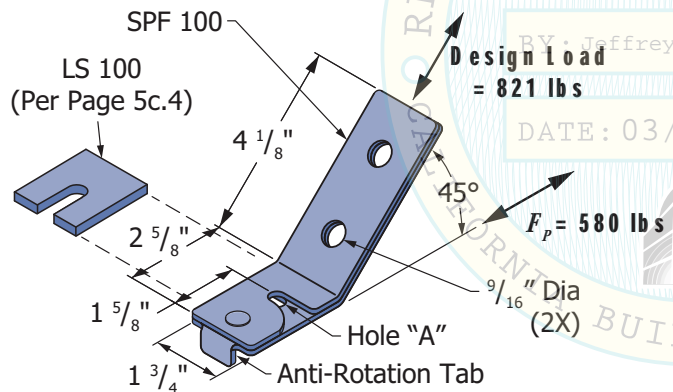

Material / Finish Specifications	
All Fittings on this Page Except P3860	
Material: ASTM A1011 SS Grade 33 min. or ASTM A1011 SS Grade 45 min.	
Finish: ASTM B633 Type III SC1 (EG)	

Part No.	Rod Size	Hole Size "A" (Dia.)
SPF 100-050	1/2"	9/16"
SPF 100-062	5/8"	1 1/16"
SPF 100-075	3/4"	1 3/16"

Note:

- 1) Loads based on 1/2" HHCS or HSSB Bolt, and 1/2" Channel Nut.
- 2) All fitting connections must conform to one of the details in Section 5a. All holes in each fitting must have one of these connections unless otherwise noted in the above details. Other components are hidden on this page for clarity.
- 3) Fitting Dimensions (all this page) unless otherwise noted: Hole Diameter: 9/16"; Hole Spacing - From End: 1 3/16"; Hole Spacing - On Center: 1 7/8"; Width: 1 5/8"; Thickness: 1/4" or 0.22".
- 4) P3825-050 is to be connected to Telespar per Page 5a.8 and capacities on that page may govern.



16100 S. Lathrop Ave
Harvey, IL 60426
Toll-Free: (800) 882-5543

www.unistrutseismic.com

Rami Elhassan
Structural Engineer: Rami Elhassan
California SE No. 3930

Page:

5c.2

Brace Fittings

BRACE FITTINGS – RETROFIT, HINGED

P3840-050 + P3860

FOR STRUT BRACE

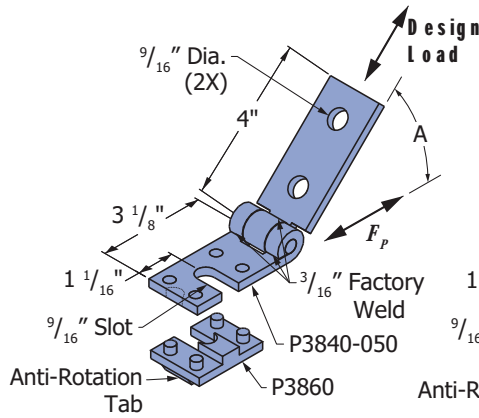

P3845-050 + P3860

FOR TELES PAR BRACE

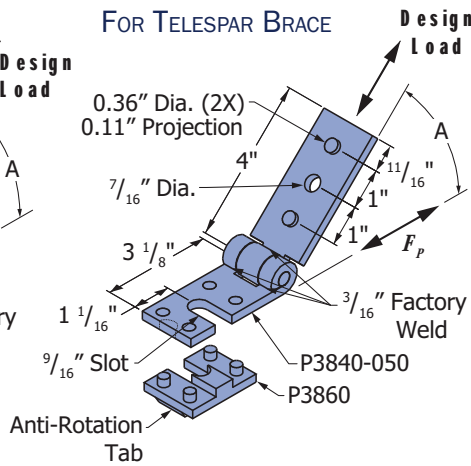

All Fittings on This Page

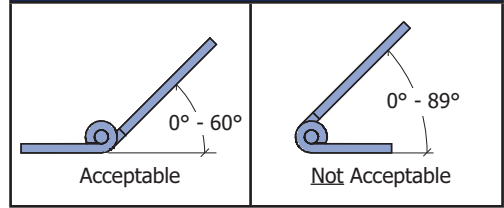

Fittings: P3840-050, P3845-050

Angle (A) from Horizontal	Design Load (lbs)	F_P (lbs)
30° +5° / -25°	2,136	1,850
45° +5° / -10°	1,397	985
60° +0° / -10°	1,462	730

SPF 200-XXX + LS 200

FOR STRUT BRACE

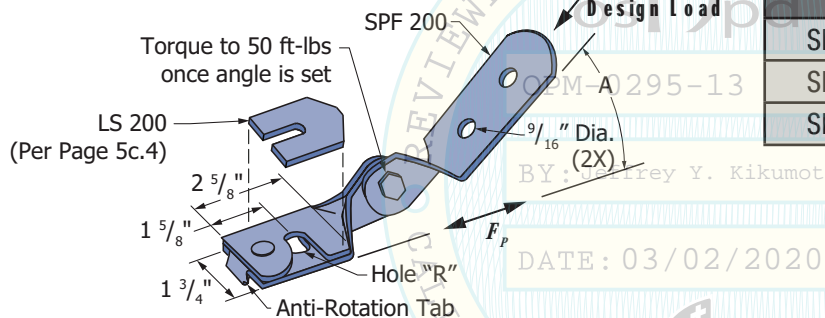

Part No.	Rod Size	Rod Hole Size "R" (Dia.)
SPF 200-050	1/2"	9/16"
SPF 200-062	5/8"	1 1/16"
SPF 200-075	3/4"	1 3/16"

Angle (A) from Horizontal	Design Load (lbs)	F_P (lbs)
30° +5° / -25°	1,042	900
45° +5° / -10°	821	580
60° +0° / -10°	667	330

Material / Finish Specifications
All Fittings on This Page Except P3860

Material: ASTM A1011 SS Grade 33 min. or
ASTM A1011 HSLAS Grade 45 min.

Finish: ASTM B633 Type III SC1 (EG)

Note:

- 1) Loads based on 1/2" HHCS or HSSB Bolt, and 1/2" Channel Nut.
- 2) All fitting connections must conform to one of the details in Section 5a. All holes in each fitting must have one of these connections unless otherwise noted in the above details. Other components are hidden on this page for clarity.
- 3) Fitting dimensions (all this page) unless otherwise noted: Hole Diameter: 9/16"; Hole Spacing - From End: 1 3/16"; Hole Spacing - On Center: 1 7/8"; Width: 1 5/8"; Thickness: 1/4" or 0.22".
- 4) P3845-050 is to be connected to Telespar per Page 5a.8 and capacities on that page may govern.
- 5) P3840-050 and P3845-050 may have a partial hole as shown with dotted lines in the images above.



16100 S. Lathrop Ave
Harvey, IL 60426
Toll-Free: (800) 882-5543

www.unistrutseismic.com

Structural Engineer: Rami Elhassan
California SE No. 3930

Page:

5c.3

Brace Fittings

BRACE FITTINGS – RETROFIT ACCESSORIES

P3860

USE WITH P3820-050, P3825-050, P3840-050 AND P3845-050 ON PAGES 5c.2 & 5c.3

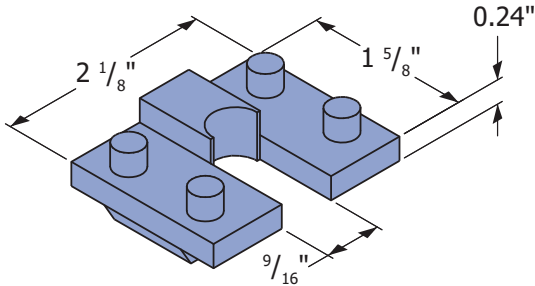

Material / Finish Specifications P3860

Material: P/M Nickel Steel FN-0208-S
Finish: ASTM B633 Type III SC1 (EG)

LS 100

USE WITH SPF 100-XXX ON PAGE 5c.2

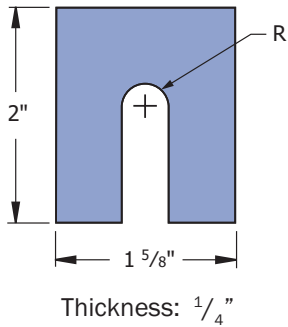

LS 200

USE WITH SPF 200-XXX ON PAGE 5c.3

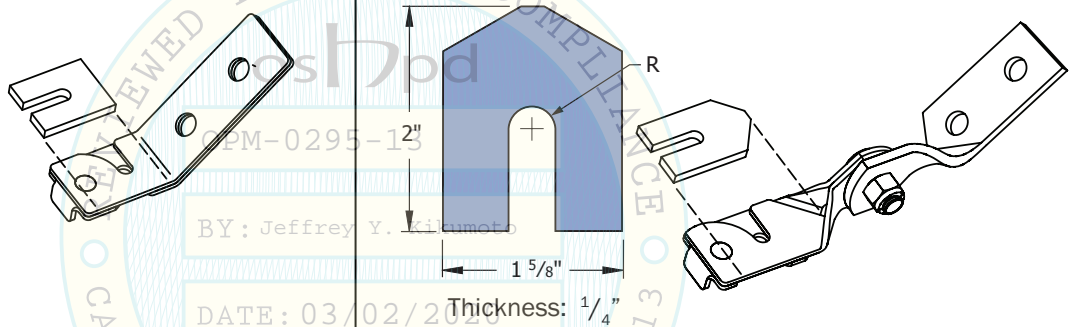

Part No.	Rod Size	Rod Hole Size "R" (Dia.)
LS 100-050	1/2"	9/16"
LS 100-062	5/8"	11/16"
LS 100-075	3/4"	13/16"

Part No.	Rod Size	Rod Hole Size "R" (Dia.)
LS 200-050	1/2"	9/16"
LS 200-062	5/8"	11/16"
LS 200-075	3/4"	13/16"

Material / Finish Specifications LS 100 and LS 200

Material: ASTM A1011 SS Grade 33 min.
Finish: ASTM B633 Type III SC1 (EG)

Note:

- Accessories on this page are to be used with Fittings on pages 5c.2 and 5c.3 as noted on those pages. Reference those pages for additional details.



16100 S. Lathrop Ave
Harvey, IL 60426
Toll-Free: (800) 882-5543

www.unistrutseismic.com

Structural Engineer: Rami Elhassan
California SE No. 3930

Page:

5c.4

Brace Fittings

P3880

FOR USE WITH STRUT OR PIPE

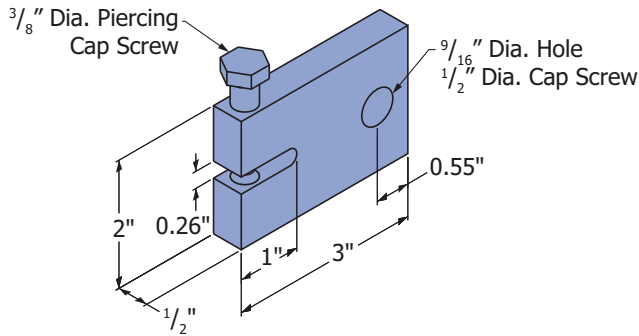

Material / Finish Specifications

P3880

Material: ASTM A1011 SS Grade 33 min. or ASTM A36

Finish: ASTM B633 Type III SC1 (EG)

When Attached to Channel or Telespar	
Angle from Horizontal	F_P (lbs)
0° +5° / -0°	1,629
30° +5° / -25°	1,410
45° +5° / -10°	1,150
60° +0° / -10°	815

ATTACHMENT TO STRUT

NON-PIERCED (SOLID) STRUT

PIERCED STRUT

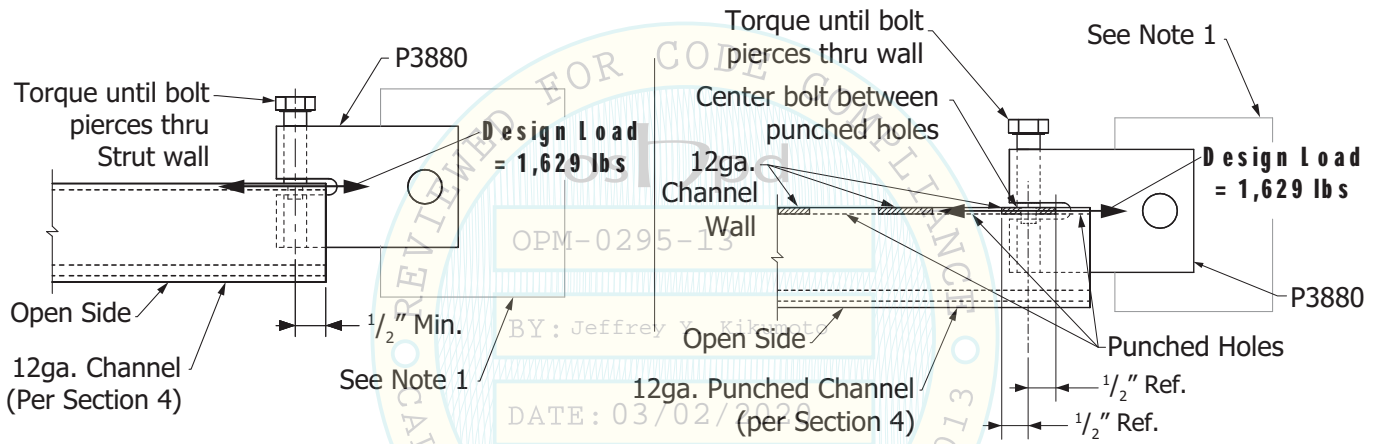

ATTACHMENT TO PIPE

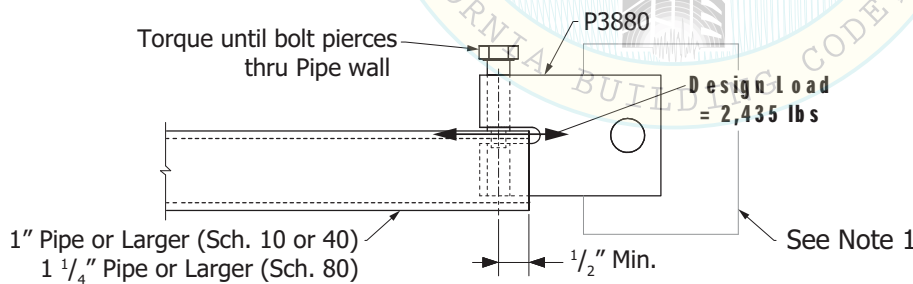

When Attached to Pipe	
Angle from Horizontal	F_P (lbs)
0° +5° / -0°	2,435
30° +5° / -25°	2,110
45° +5° / -10°	1,725
60° +0° / -10°	1,220

Note:

- 1) This fitting is typically intended to be attached to metal capable of resisting the seismic force and/or as designed by the RDP/SEOR, which may include one or more clip angles.
- 2) Attachment requirements - For Steel: Minimum grade A36 at 1/4" thickness. For Wood: Per Note 3 on Page 1j.1. For Aluminum: Minimum grade 6061-T6 at 1/2" thickness.
- 3) Loads based on 1/2" diameter HHCS bolt through minimum 1/4" thick A36 steel with 3/4" minimum edge distance.



16100 S. Lathrop Ave
Harvey, IL 60426
Toll-Free: (800) 882-5543

www.unistrutseismic.com

Structural Engineer: Rami Elhassan
California SE No. 3930

Page:

5c.5

Pipe, Conduit & Tube Clamps

PIPE, CONDUIT & TUBE CLAMPS

P1100 SERIES

FOR RIGID STEEL CONDUIT OR SCHEDULE 10, 40, 80 STEEL PIPE

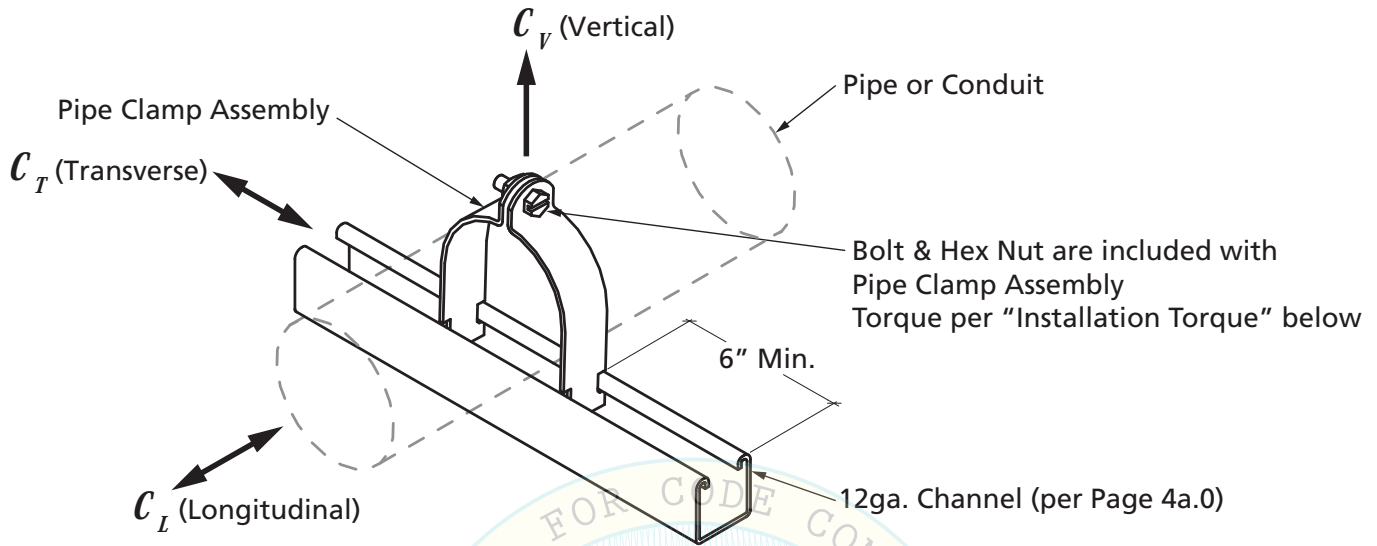

P1100 Series Pipe Clamps - Sch. 10, 40, 80 Pipe, RMC Conduit

Pipe Clamp Part Number	Nominal Pipe Size	Maximum Horizontal F_p Force (lbs)			Installation Torque (ft-lbs)
		Max. Vertical Capacity (lbs)	C_T Transverse	C_L Longitudinal	
P1111*	1/2"	1,285	350	315	6
P1112*	3/4"	1,940	310	390	6
P1113*	1"	1,940	310	390	6
P1114*	1 1/4"	1,940	310	390	6
P1115*	1 1/2"	1,940	310	390	11
P1117	2"	2,720	480	825	11
P1118	2 1/2"	2,090	360	730	11
P1119	3"	2,090	360	730	11
P1120	3 1/2"	2,090	360	730	19
P1121	4"	2,090	360	730	19
P1123	5"	2,090	360	525	19
P1124	6"	2,090	360	525	19
P1126	8"	3,555	1,180	525	19

Notes:

- 1) See Page 5d.4 for full product specifications.
- 2) * Schedule 40 or heavier Pipe or RMC Conduit only



16100 S. Lathrop Ave
Harvey, IL 60426
Toll-Free: (800) 882-5543

www.unistrutseismic.com

Structural Engineer: Rami Elhassan
California SE No. 3930

Page:

5d.1

Pipe, Conduit & Tube Clamps

EMT & IMC CONDUIT CLAMPS

P1400 SERIES

FOR THIN WALL CONDUIT (EMT & IMC)

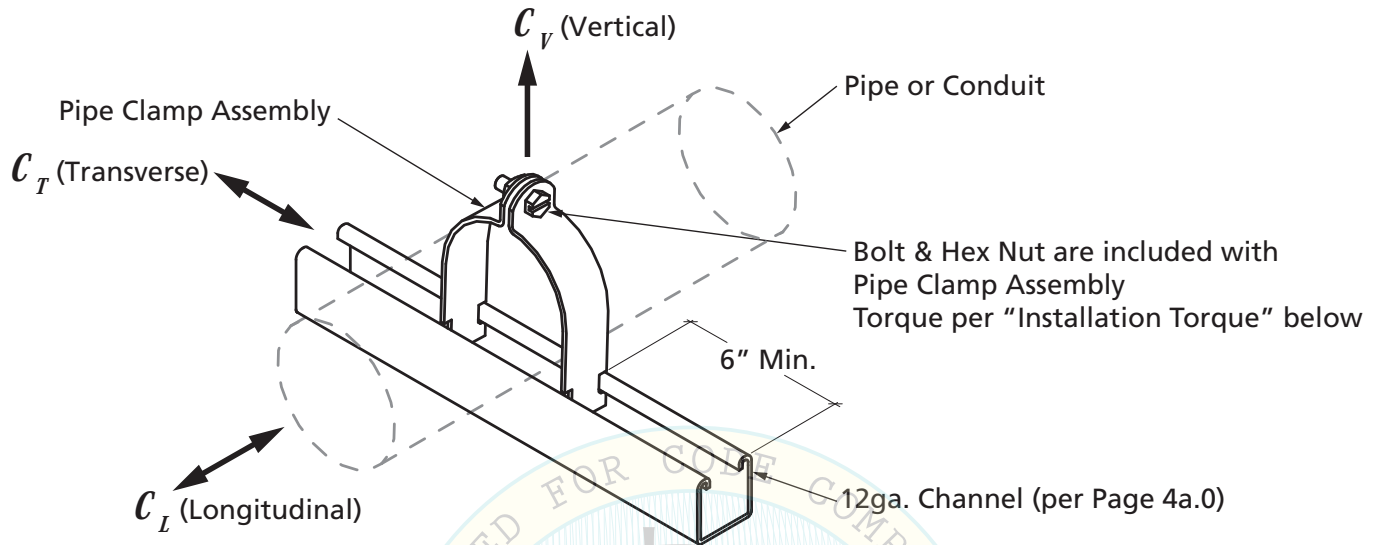

P1400 Series Pipe Clamps - For EMT, IMC Conduit

Pipe Clamp Part Number	Nominal Pipe Size	Maximum Horizontal F_p Force (lbs)			Installation Torque (ft-lbs)
		C_V Vertical	C_T Transverse	C_L Longitudinal	
P1426	1/2"	340	270	345	6
P1427	3/4"	340	270	345	6
P1428	1"	1,015	325	605	6
P1429	1 1/4"	1,015	325	505	6
P1430	1 1/2"	1,015	325	505	11
P1431	2"	1,555	335	505	11
P1118	2 1/2"	1,475	335	505	11
P1119	3"	1,475	335	505	11
P1120	3 1/2"	1,475	335	505	19
P1121	4"	1,475	545	640	19

Note:

1) See Page 5d.4 for full product specifications.



16100 S. Lathrop Ave
Harvey, IL 60426
Toll-Free: (800) 882-5543

www.unistrutseismic.com

Structural Engineer: Rami Elhassan
California SE No. 3930

Page:

5d.2

Pipe, Conduit & Tube Clamps

COPPER PIPE & TUBE CLAMPS

P2000 SERIES & P1430 + P2600 UNICUSHION

FOR COPPER PIPE OR TUBE

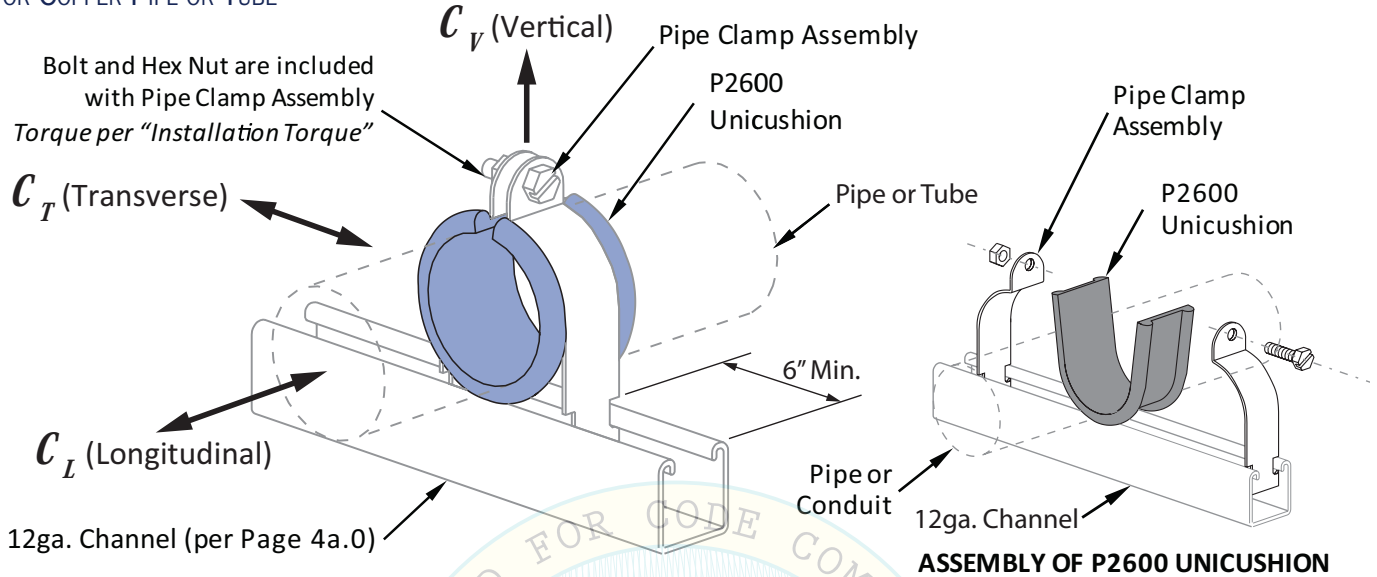

P2000 Series & P1430 Pipe Clamps - For Copper Pipe or Tube (Types K, L, M)

Pipe Clamp Part Number	P2600 UNICUSHION Part Number	P2600 UNICUSHION Cut Length	Nominal Pipe Size	Max. Vertical Capacity (lbs) C_V Vertical	Maximum Horizontal F_P Force (lbs)		Installation Torque (ft-lbs)
					C_T Transverse	C_L Longitudinal	
P2027	P2600	1 1/2"	3/8"	130	75	65	6
P2028	P2600	2 1/8"	1/2"	130	75	65	6
P2029	P2600	2 1/4"	5/8"	130	75	65	6
P2030	P2600	3"	3/4"	355	100	85	6
P2032	P2600	3 5/8"	1"	355	100	85	6
P2034	P2600	4 1/2"	1 1/4"	355	100	85	6
P1430	P2600	5 1/4"	1 1/2"	355	100	85	11
P2040	P2600	6 3/4"	2"	1,165	265	290	11
P2044	P2600	8 1/4"	2 1/2"	1,165	265	290	11
P2048	P2600	10"	3"	1,165	265	290	11
P2052	P2600	11 1/4"	3 1/2"	1,165	265	290	19
P2056	P2600	12 1/2"	4"	1,525	275	435	19

Note:

1) See Page 5d.4 for full product specifications.



16100 S. Lathrop Ave
Harvey, IL 60426
Toll-Free: (800) 882-5543

www.unistrutseismic.com

Rami Elhassan
Structural Engineer: Rami Elhassan
California SE No. 3930

Page:

5d.3

Pipe, Conduit & Tube Clamps

PIPE, CONDUIT & TUBE CLAMP SPECIFICATIONS

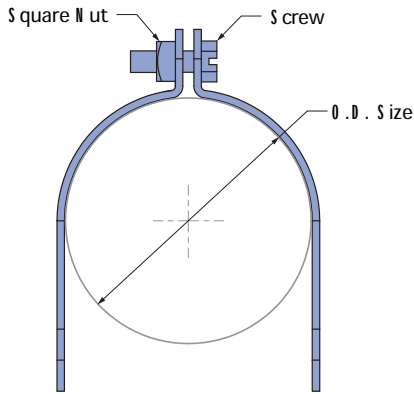

Material / Finish Specifications All Pipe Clamps in Table

Materials:

Clamps: ASTM A1011 SS Gr 33 min.

Screw: SAE J429 GR 2

Square Nut: ASTM A563, Grade A

Finish: ASTM B633 Type III SC1 (EG)

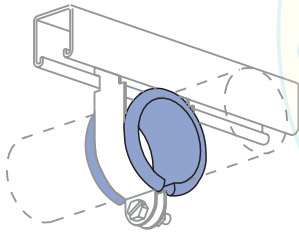

Material / Finish Specifications P2600 Unicushion

Materials: Silicone Elastomer

Durometer: 65 - 75 on a Shore A Scale

Part Number	Nominal Pipe Size	O.D. Size	Thickness	Screw & Nut (Thread)	Weight (lbs)
P1111	1/2"	0.840"	16 ga.	1/4"-20	0.11
P1112	3/4"	1.050"	14 ga.	1/4"-20	0.15
P1113	1"	1.315"	14 ga.	1/4"-20	0.17
P1114	1 1/4"	1.660"	14 ga.	1/4"-20	0.19
P1115	1 1/2"	1.900"	12 ga.	5/16"-18	0.29
P1117	2"	2.375"	12 ga.	5/16"-18	0.34
P1118	2 1/2"	2.875"	12 ga.	5/16"-18	0.40
P1119	3"	3.500"	12 ga.	5/16"-18	0.47
P1120	3 1/2"	4.000"	11 ga.	3/8"-16	0.62
P1121	4"	4.500"	11 ga.	3/8"-16	0.67
P1123	5"	5.563"	11 ga.	3/8"-16	0.80
P1124	6"	6.625"	10 ga.	3/8"-16	1.20
P1126	8"	8.625"	10 ga.	3/8"-16	1.30
P1426	1/2"	0.706"	16 ga.	1/4"-20	0.11
P1427	3/4"	0.922"	16 ga.	1/4"-20	0.12
P1428	1"	1.163"	14 ga.	1/4"-20	0.15
P1429	1 1/4"	1.510"	14 ga.	1/4"-20	0.18
P1430	1 1/2"	1.740"	12 ga.	5/16"-18	0.29
P1431	2"	2.197"	12 ga.	5/16"-18	0.33
P2027	3/8"	0.625"	16 ga.	1/4"-20	0.10
P2028	1/2"	0.750"	16 ga.	1/4"-20	0.11
P2029	5/8"	0.875"	16 ga.	1/4"-20	0.12
P2030	3/4"	1.000"	14 ga.	1/4"-20	0.14
P2032	1"	1.250"	14 ga.	1/4"-20	0.16
P2034	1 1/4"	1.500"	14 ga.	1/4"-20	0.18
P2040	2"	2.250"	12 ga.	5/16"-18	0.33
P2044	2 1/2"	2.750"	12 ga.	5/16"-18	0.38
P2048	3"	3.250"	12 ga.	5/16"-18	0.45
P2052	3 1/2"	3.750"	12 ga.	3/8"-16	0.58
P2056	4"	4.250"	11 ga.	3/8"-16	0.64



16100 S. Lathrop Ave
Harvey, IL 60426
Toll-Free: (800) 882-5543

www.unistrutseismic.com

Rami Elhassan
Structural Engineer: Rami Elhassan
California SE No. 3930

Page:

5d.4

Cable Tray Supports

CABLE TRAY SUPPORTS

MUST BE USED IN PAIRS

9132R

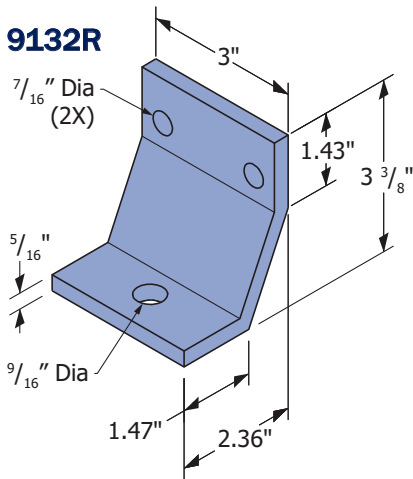

9132S

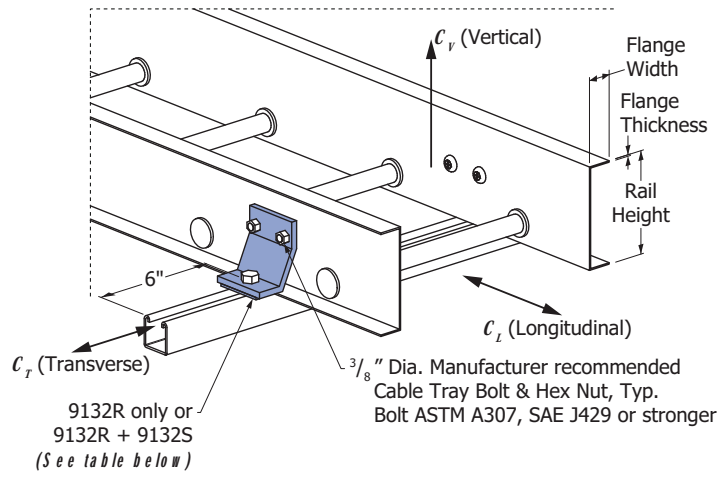
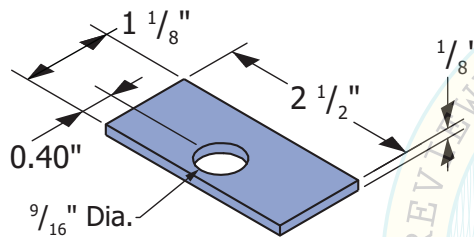

Design Loads (lbs) (Total Per Pair)		
C_V Vertical	C_T Transverse	C_L Longitudinal
1,210	1,370	1,210

Notes: 1) Clamps must be used in pairs, as shown

DETAIL 5E.1-1: CABLE TRAY ATTACHMENT TO STRUT

OPM-0295-13
 BY: Jeffrey Y. Kikumoto
 DATE: 03/02/2020
 Steel Cable Tray
 Rails ASTM A653 Gr 33, ASTM 1008 Gr 33
 ASTM A1011 Gr 33 or stronger
 12 ga. Min. Thickness
 (2) 3/8" Dia. Manufacturer recommended
 Cable Tray Bolt & Hex Nut, Typ.
 Bolt ASTM A307, SAE J429 or stronger
 Connection per Page 5a.1

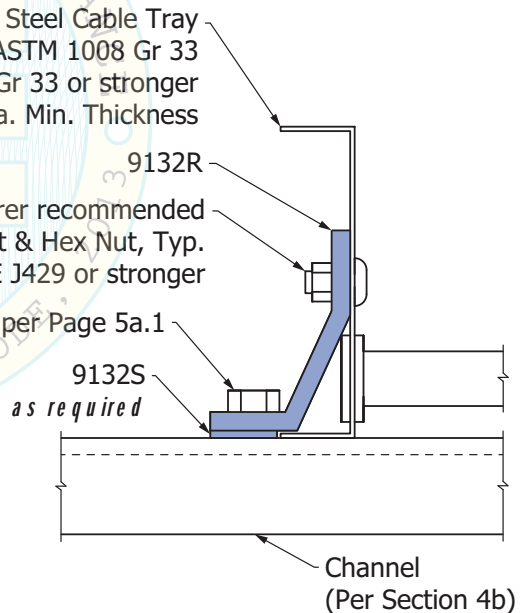







Material / Finish Specifications
9132R, 9132S
Material: ASTM A36 Steel
Finish: ASTM A153 (HDGAF)

Flange	Rail Height	Flange Width	Flange Thickness	Use
Flange Facing Inward	3 1/2" or Greater	Any	Any	9132R Only
Flange Facing Outward	3 5/8" or Greater	1 1/4" Max.	1/8" Max.	9132R + 9132S

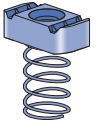
- Notes:**
- 1) Designer shall confirm cable tray attachment values which may govern.
 - 2) Cable Tray shall be approved on a project specific basis, or preapproved by OSHPD. Spacing limits set by the manufacturer shall not be exceeded. Cable Tray brace spacing shall be approved or preapproved by OSHPD.

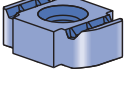
<p>www.unistrutseismic.com</p>	16100 S. Lathrop Ave Harvey, IL 60426 Toll-Free: (800) 882-5543		Page:
			Structural Engineer: Rami Elhassan California SE No. 3930

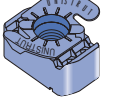
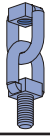
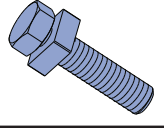
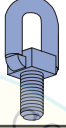
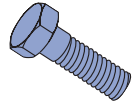
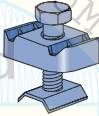
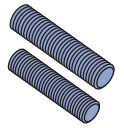
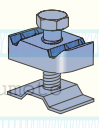
Components: Channel Nuts & Hardware

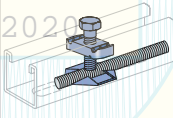
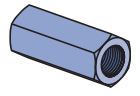
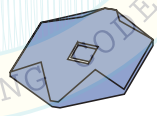
PART NUMBERS		PAGE	PART NUMBERS		PAGE
	P1010 P1012S P5510	6a.1		HFLW	6c.2
	P3008 P1012 P3010	6a.1		HLKW	6c.2
	P1010T	6a.1		M2137 M2150	6c.2
	HSSB050162	6b.1		M2350	6c.2
	HHCS	6c.1		P2486	6d.1 - 6d.3
	HTHR	6c.1		P2486US	6d.1 - 6d.3
	HHXN	6c.1		P2485K	6d.1 - 6d.3
	HRCN	6c.1		P2485	6d.1 - 6d.3



16100 S. Lathrop Ave
Harvey, IL 60426
Toll-Free: (800) 882-5543

www.unistrutseismic.com

Structural Engineer: Rami Elhassan
California SE No. 3930

Page:

6a.0

Channel Nuts

P1010, P1012S, P5510

WITH SPRING

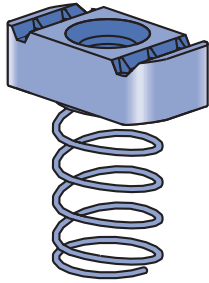

P3008, P1012, P3010

WITHOUT SPRING

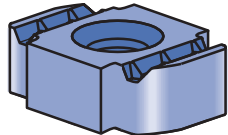

P1010T

TOP GRIP

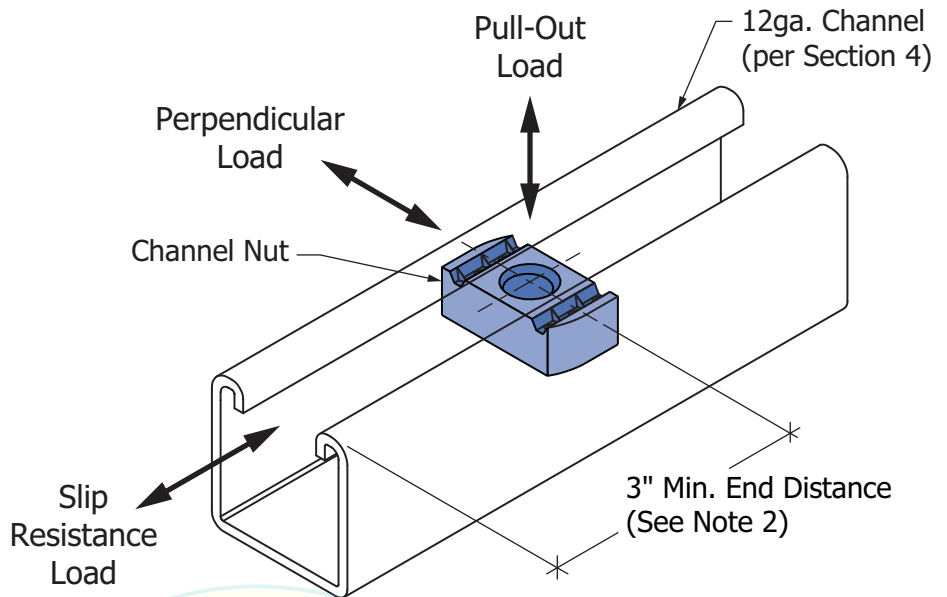
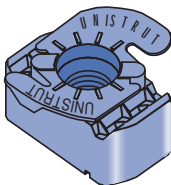

Notes:

- 1) Fitting and Cap Screw not shown for clarity. See Section 5a for full installation requirements.
- 2) For end distances less than 3", use Wolf Washer. Refer to Page 5b.1.
- 3) This information applies only to Unistrut brand Channel Nuts. All Unistrut Channel Nuts are stamped with the name "UNISTRUT".

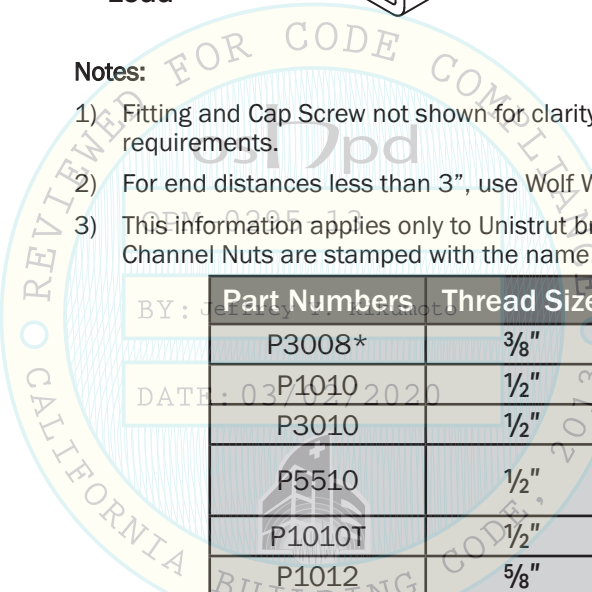

Part Numbers	Thread Size	Use With
P3008*	3/8"	Any Channel in OPM
P1010	1/2"	P1000, P1001
P3010	1/2"	Any Channel in OPM
P5510	1/2"	P5500, P5501, P5000, P5001
P1010T	1/2"	Any Channel in OPM
P1012	5/8"	Any Channel in OPM
P1012S	5/8"	P1000, P1001

*P3008 is not to be used with a seismic brace

Material/Finish Specifications P1010T
Material: ASTM B783, FN-0205-80HT
Finish: ASTM B633 Type III SC1 (EG)
Case Hardened

Material/Finish Specifications P1012S, P1012
Material: ASTM A675 GR 60
Finish: ASTM B633 Type III SC1 (EG)
Case Hardened

Material/Finish Specifications P1010, P5510, P3010, P3008
Material: ASTM A576 GR 1015 Modified
Finish: ASTM B633 Type III SC1 (EG)
Case Hardened



16100 S. Lathrop Ave
Harvey, IL 60426
Toll-Free: (800) 882-5543

www.unistrutseismic.com

Rami Elhassan
Structural Engineer: Rami Elhassan
California SE No. 3930

Page:

6a.1

Break-Off Head Bolt

HSSB050162

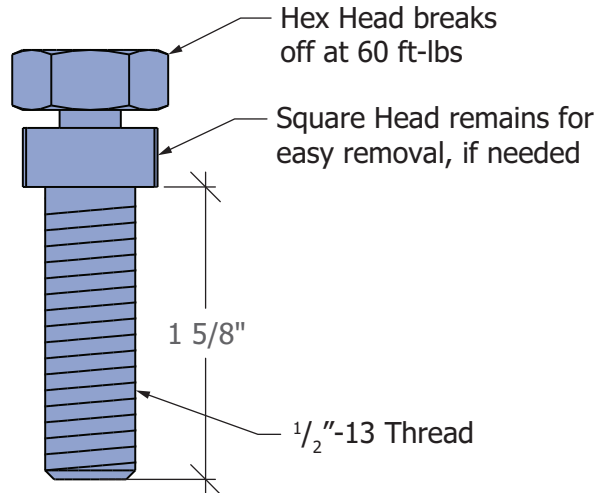
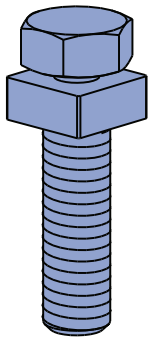

DETAIL 6B.1-1: TYPICAL HSSB050162 CONNECTION TO STRUT

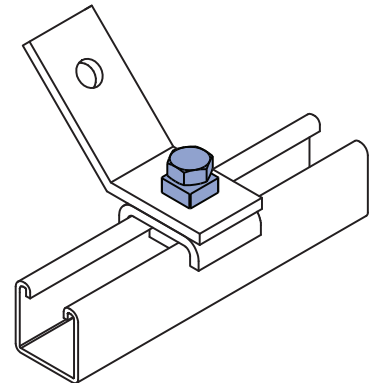
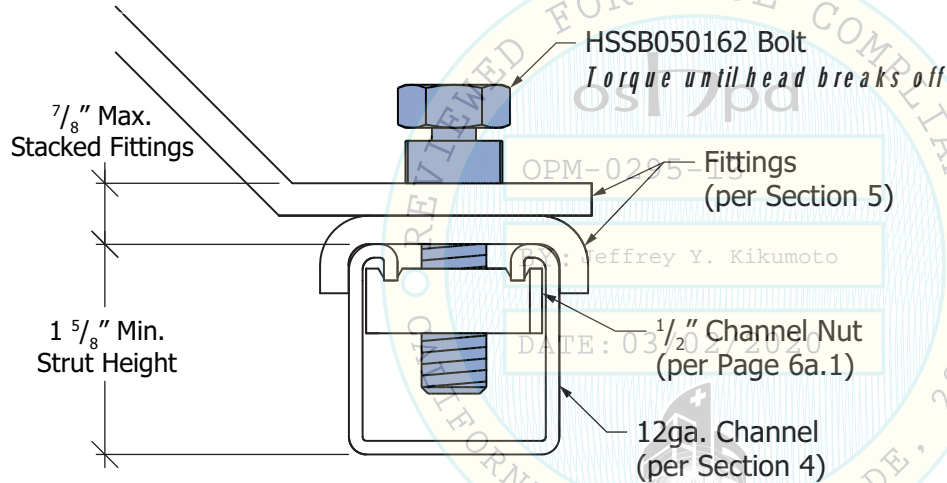

BEFORE HEAD BREAKS OFF

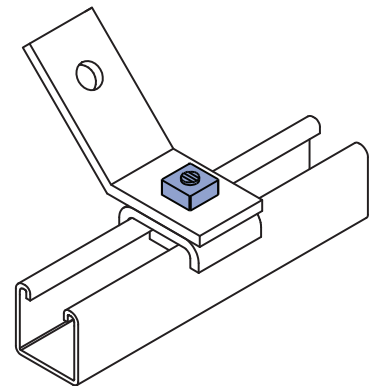

AFTER HEAD BREAKS OFF

Material / Finish Specifications

Material: SAE J429 GR 2

Finish: ASTM B633 Type III SC1 (EG)

Atkore
Unistrut

16100 S. Lathrop Ave
Harvey, IL 60426
Toll-Free: (800) 882-5543

www.unistrutseismic.com

Rami Elhassan

Structural Engineer: Rami Elhassan
California SE No. 3930

Page:

6b.1

General Hardware

HEX HEAD CAP SCREW (HHCS)

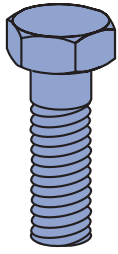

Part Number	Thread Size	Length
HHCS037075	3/8"	3/4"
HHCS037100	3/8"	1"
HHCS037125	3/8"	1 1/4"
HHCS037150	3/8"	1 1/2"
HHCS050094	1/2"	15/16"
HHCS050119	1/2"	1 3/16"
HHCS050150	1/2"	1 1/2"

Material / Finish Specifications

Material: SAE J429 GR 2

Finish: ASTM B633 Type III SC1 (EG)

HEX NUTS (HHXN)

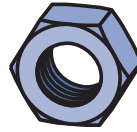

Part Number	Thread Size
HHXN037	3/8"
HHXN050	1/2"
HHXN062	5/8"

Material / Finish Specifications

Material: ASTM A563, Grade A

Finish: ASTM B633 Type III SC1 (EG)

Dimensions in accordance with ANSI B18.2.2

STEEL THREADED ROD (HTHR)

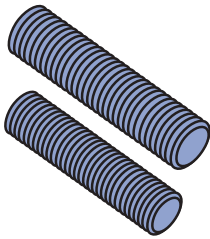

Part Number	Thread Size
HTHR037	3/8"
HTHR050	1/2"
HTHR062	5/8"

Material / Finish Specifications

Material: ASTM A36 or F1554 GR 36 minimum

Finish: ASTM B633 Type III SC1 (EG)

Yield Strength: 36,000 psi minimum

STEEL COUPLER NUTS (HRCN)

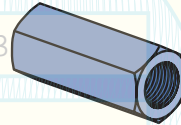

Part Number	Thread Size	Length
HRCN037	3/8"	1 3/4"
HRCN050	1/2"	1 3/4"
HRCN062	5/8"	2 1/8"

Material / Finish Specifications

Material: ASTM A563, Grade A

Finish: ASTM B633 Type III SC1 (EG)

Atkore
Unistrut

16100 S. Lathrop Ave
Harvey, IL 60426
Toll-Free: (800) 882-5543

www.unistrutseismic.com

Rami Elhassan
Structural Engineer: Rami Elhassan
California SE No. 3930

Page:

6c.1

General Hardware

FLAT WASHERS (HFLW)

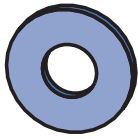

Part Number	Thread Size
HFLW037	3/8"
HFLW050	1/2"
HFLW062	5/8"

Material / Finish Specifications

Material: ASTM F844

Finish: ASTM B633 Type III SC1 (EG)

Dimensions in accordance with ANSI B18.22.1, Type A

LOCK WASHERS (HLKW)

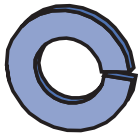

Part Number	Thread Size
HLKW037	3/8"
HLKW050	1/2"
HLKW062	5/8"

Material / Finish Specifications

Material: ASTM A29, Grades 1055-1065

Finish: ASTM B695, Class 5, Type 1 (EG)

Dimensions in accordance with ANSI B18.21.1

SWIVEL HANGERS

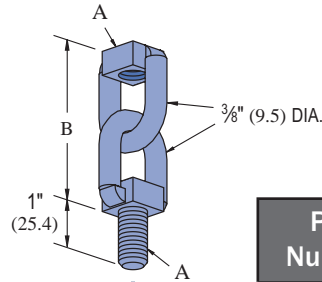

Part Number	Thread Size (A)	Length (B)
M2137	3/8"	2 29/32"
M2150	1/2"	2 3/4"

$F_1 = 600$ lbs

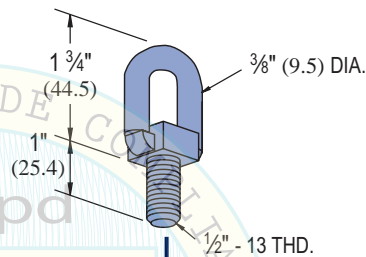

$F_1 = 600$ lbs

Part Number
M2350

Design Load (F_1) = 600 lbs.

Material / Finish Specifications

Materials:

Sq. Head Bolt: Low Carbon Steel Grade 1006 - 1010

Sq. Nut: ASTM A563, Grade A

U-Rod: ASTM A108, Grade 1018

Finish: ASTM B633 Type III SC1 (EG)

Atkore
Unistrut

16100 S. Lathrop Ave
Harvey, IL 60426
Toll-Free: (800) 882-5543

www.unistrutseismic.com

Rami Elhassan
Structural Engineer: Rami Elhassan
California SE No. 3930

Page:

6c.2

Rod Stiffeners

P2486 - SEISMIC ROD STIFFENER

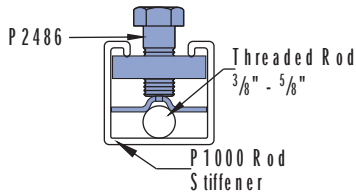
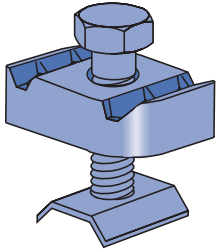

P2486US - SEISMIC ROD STIFFENER

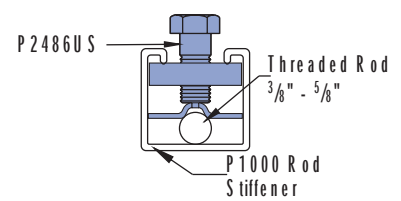
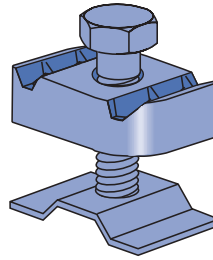

Material / Finish Specifications

Materials:

Channel Nut: ASTM A576 G1015 Mod.

Cap Screw: SAE J429 GR 2

Plate: ASTM A1011 SS GR 33

Finish: ASTM B633 Type III SC1 (EG)

Material / Finish Specifications

Materials:

Channel Nut: ASTM A576 G1015 Mod.

Cap Screw: SAE J429 GR 2

Plate: ASTM A1011 SS GR 33

Finish: ASTM B633 Type III SC1 (EG)

P2485K - CRADLE CLIP ASSEMBLY

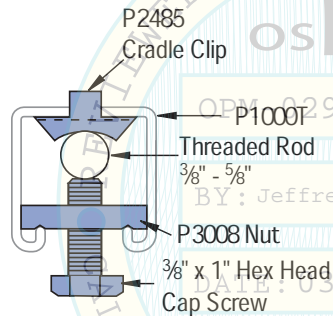
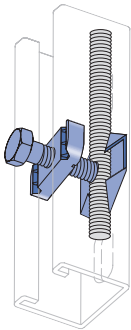

P2485 - CRADLE CLIP

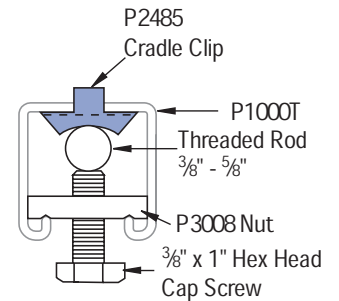
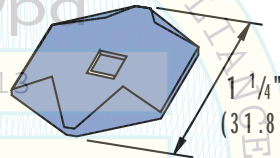

Cradle clip only, order other items separately.

Material / Finish Specifications

Materials:

Channel Nut: ASTM A675 GR 60

Cap Screw: SAE J429 GR 2

Cradle Clip: ASTM A366-85

Finish: ASTM B633 Type III SC1 (EG)

Material / Finish Specifications

Material: ASTM A366-85

Finish: ASTM B633 Type III SC1 (EG)



16100 S. Lathrop Ave
Harvey, IL 60426
Toll-Free: (800) 882-5543

www.unistrutseismic.com

Structural Engineer: Rami Elhassan
California SE No. 3930

Page:

6d.1

Rod Stiffeners

ROD STIFFENER

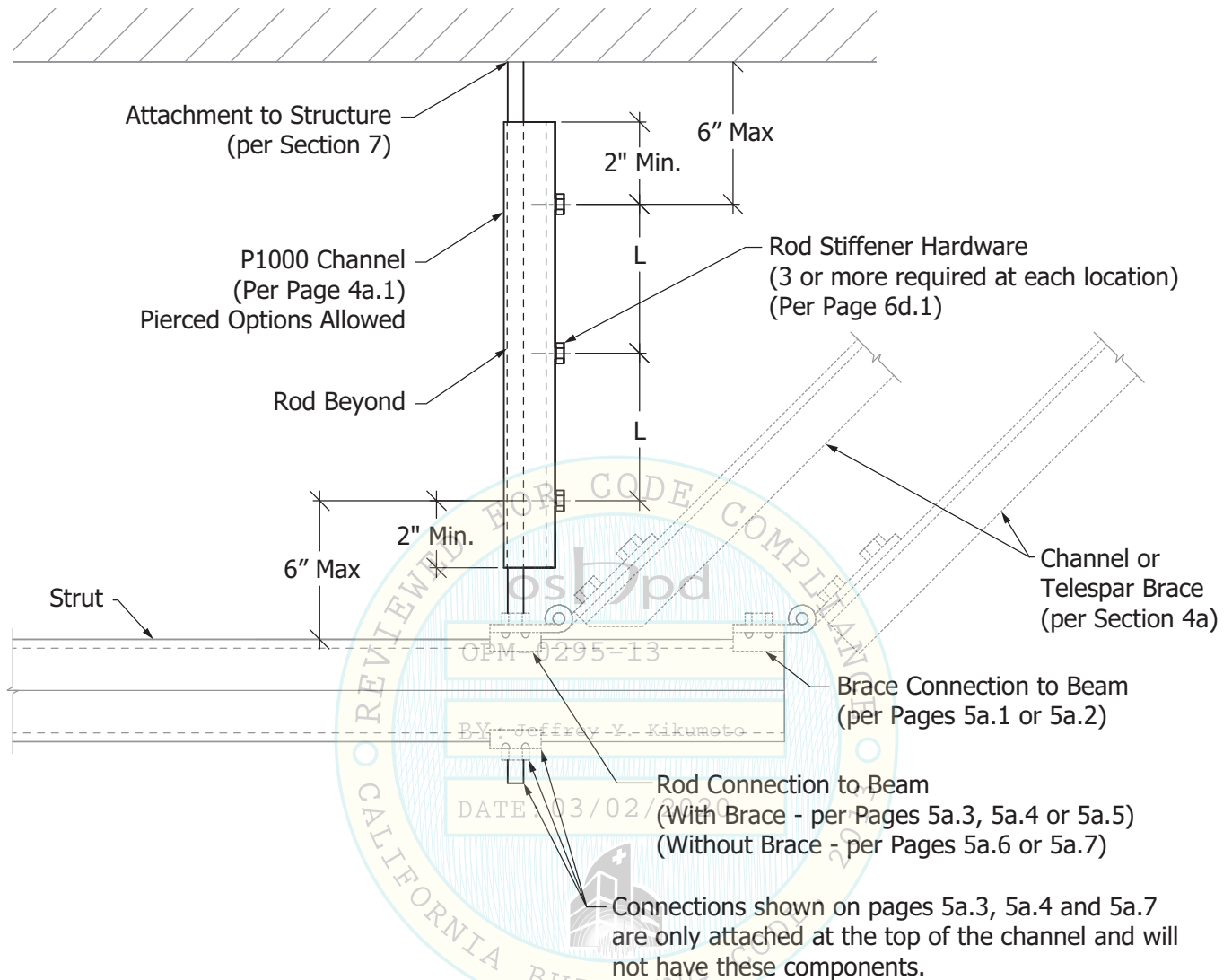

Note:

- 1) Where the length of the rod is less than "L" and the max F_p Force is not exceeded per the tables on sheet 6d.3, rod stiffeners and strut are not required. If the length of the rod exceeds 30", a rod stiffener will be required.

Atkore
Unistrut

16100 S. Lathrop Ave
Harvey, IL 60426
Toll-Free: (800) 882-5543

www.unistrutseismic.com

Structural Engineer: Rami Elhassan
California SE No. 3930

Page:

6d.2

Rod Stiffeners

Maximum Horizontal F_p Force (lbs.) ASD								
3/8" Diameter Rod	"L" Clip/Bolt Spacing (in.)	Max Total Rod Length (ft.)	Lateral Brace Angle (Deg.)					
			0° +5° / -0° (Horizontal)	30° +5° / -25°	45° +5° / -10°	60° +0° / -10°		
			Brace Capacity Governs (See Section 3 for Maximum Horizontal F_p Force for Brace)				1,164	684
9	7.4	685					402	277
12	9.8	438					258	177
15	12.2	304					179	123
18	14.7	224					131	90
21	15.0	171					101	69
24	15.0	135					79	55
27	15.0	110					64	44
30	15.0							

Maximum Horizontal F_p Force (lbs.) ASD								
1/2" Diameter Rod	"L" Clip/Bolt Spacing (in.)	Max Total Rod Length (ft.)	Lateral Brace Angle (Deg.)					
			0° +5° / -0° (Horizontal)	30° +5° / -25°	45° +5° / -10°	60° +0° / -10°		
			Brace Capacity Governs (See Section 3 for Maximum Horizontal F_p Force for Brace)				2,953	1,735
9	5.5	2,176					1,279	880
12	6.6	1,472					865	595
15	8.2	1,022					601	413
18	9.8	751					441	304
21	11.4	575					338	233
24	13.0	368					216	149
30	16.3	256					150	103
30	19.6	245					144	99
30	20.0							

Maximum Horizontal F_p Force (lbs.) ASD								
5/8" Diameter Rod	"L" Clip/Bolt Spacing (in.)	Max Total Rod Length (ft.)	Lateral Brace Angle (Deg.)					
			0° +5° / -0° (Horizontal)	30° +5° / -25°	45° +5° / -10°	60° +0° / -10°		
			Brace Capacity Governs (See Section 3 for Maximum Horizontal F_p Force for Brace)				3,516	2,066
15	6.1	2,599					1,527	1,051
18	7.2	1,462					859	591
24	9.6	936					550	378
30	11.9	650					382	263
30	14.3	365					215	148
30	19.1	333					196	135
30	20.0							



16100 S. Lathrop Ave
Harvey, IL 60426
Toll-Free: (800) 882-5543

www.unistrutseismic.com

Rami Elhassan
Structural Engineer: Rami Elhassan
California SE No. 3930

Page:

6d.3

Connections / Anchors

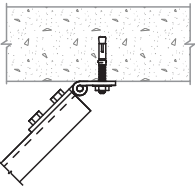
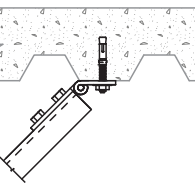
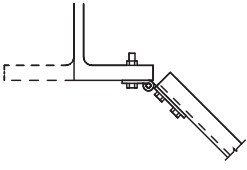
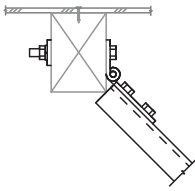
	PART NUMBER	PAGE
	Post-Installed Concrete Connections	7a.1 – 7a.2
	Post-Installed Concrete Filled Metal Deck Connections	7b.1 – 7b.2
	Steel Beam Connections	7c.1 – 7c.2
	Wood Beam Connections	7d.1 – 7d.2

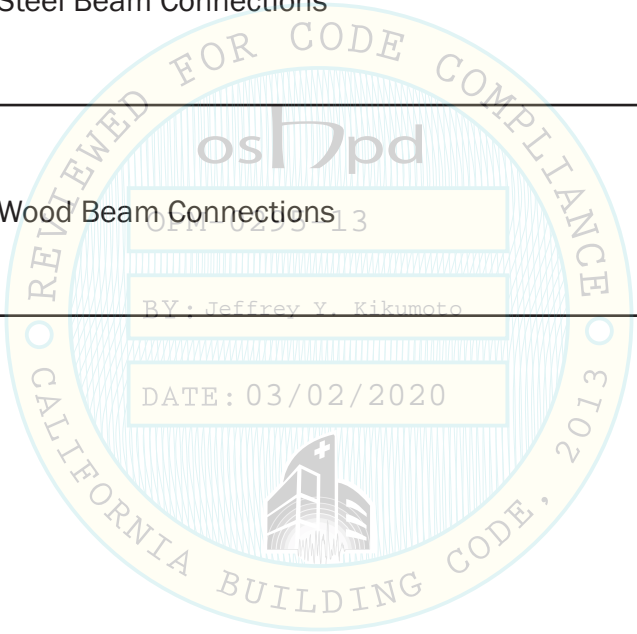

Notes:

- 1) Design is controlled by seismic forces. Non-seismic forces such as gravity are outside the scope of this OPM.
- 2) Hanger Rod at seismic brace locations is subjected to gravity loads as well as lateral and vertical seismic loads and has been designed for such combined loading in compliance with California Building Code, ASCE 7-10, and standard structural steel practices and are not subject to the hanger rod diameters designed for gravity loads only that may be outlined in project specifications, code documents, trade guidelines, etc.

 <p>16100 S. Lathrop Ave Harvey, IL 60426 Toll-Free: (800) 882-5543</p> <p align="center">www.unistrutseismic.com</p>		Page:
	Structural Engineer: Rami Elhassan California SE No. 3930	7a.0

Post Installed Concrete Connections

CONNECTIONS - EXPANSION ANCHORS INSTALLED TO UNDERSIDE OF NWC SLAB.

DETAIL 7A.1-1: SINGLE EXPANSION ANCHOR

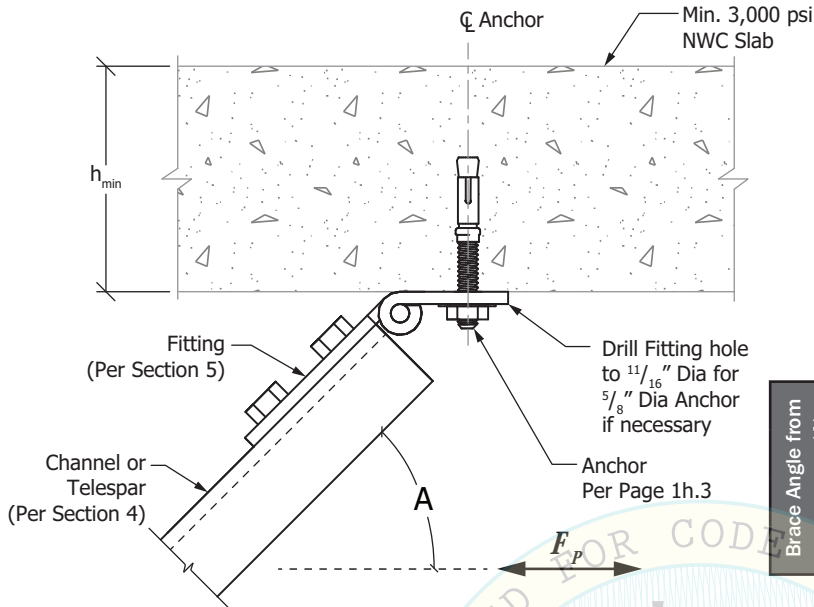

Maximum Horizontal F_p Force (lbs.)					
Anchor Diameter	1/2"		5/8"		
	Effective Embedment	3 1/4"	3 1/4"	4 1/4"	
h_{min}	5"	6"	6"	7"	
Brace Angle from Horizontal (A)	0° +5° / -0°	790	1,296	1,290	1,886
	30° +5° / -25°	514	890	914	1,332
	45° +5° / -10°	344	612	645	936
	60° +0° / -10°	212	385	414	599

DETAIL 7A.1-2: TWO EXPANSION ANCHORS

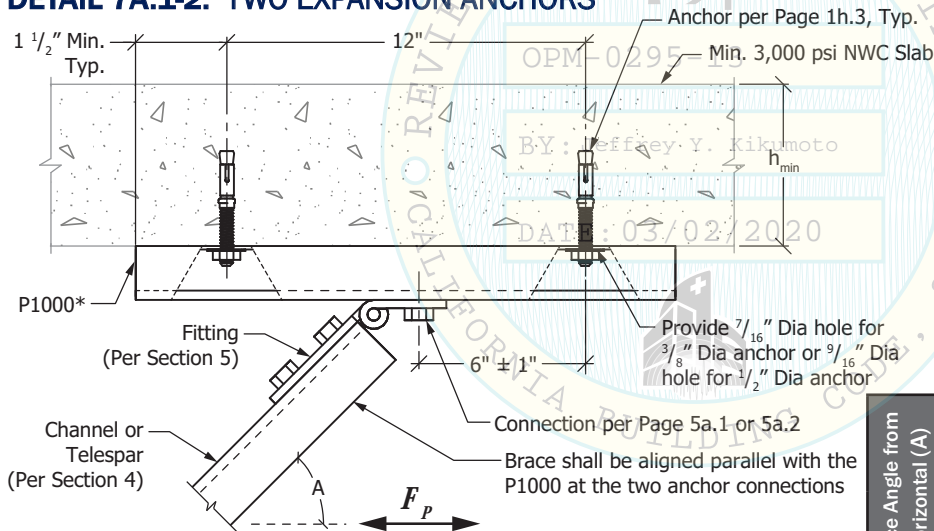

Maximum Horizontal F_p Force (lbs.)				
Anchor Diameter	3/8"		1/2" *	
	Effective Embedment	2"	2 1/4"	3 1/4"
h_{min}	5"	6"	7"	
Brace Angle from Horizontal (A)	0° +5° / -0°	1,020	1,580	2,591
	30° +5° / -25°	714	964	1,662
	45° +5° / -10°	547	709	1,239
	60° +0° / -10°	389	486	860

Notes:

- 1) See sheet 1h.3 for mechanical concrete anchor manufacturer information.
- 2) * P1000T or P1000WT may be used in place of P1000 with a P3892-50 Wolf Washer at each 1/2" \emptyset expansion bolt (see Detail 5b.2-2) with F_p limited to 705 lbs.
- 3) F_p capacities on this page are ASD capacities increased by 1.2 including Ω_0 per ASCE 7-10 §12.4.3.3. For braces at a 0° angle, the F_p capacities listed are the allowable shear capacities of the anchors in concrete divided by Ω_0 .
- 4) These values apply only when using Unistrut brand products with the anchors listed on page 1h.3.



16100 S. Lathrop Ave
Harvey, IL 60426
Toll-Free: (800) 882-5543

www.unistrutseismic.com

Rami Elhassan
Structural Engineer: Rami Elhassan
California SE No. 3930

Page:

7a.1

Post Installed Concrete Connections

CONNECTIONS - EXPANSION ANCHORS INSTALLED TO UNDERSIDE OF NWC SLAB.

DETAIL 7A.2-1: SINGLE EXPANSION ANCHOR

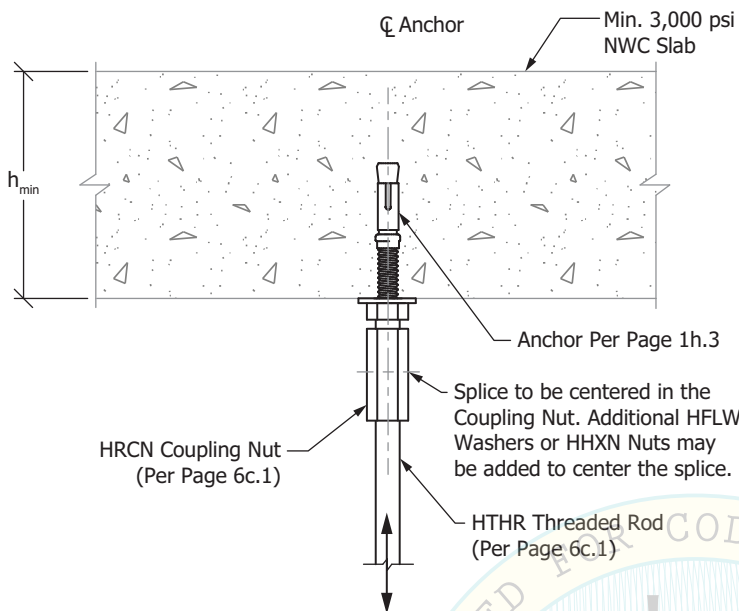

Maximum Tension Capacity (lbs.) ASD				
Anchor Diameter	3/8"	1/2"	5/8"	
Effective Embedment	2"	2 1/4"	3 1/4"	4 1/4"
h_{min}	4"	5"	6"	7 1/4"
With Seismic Load Effect ⁴	481	551	1,002	1,075
Without Seismic Load Effect	800	915	1,670	2,495

DETAIL 7A.2-2: TWO EXPANSION ANCHORS

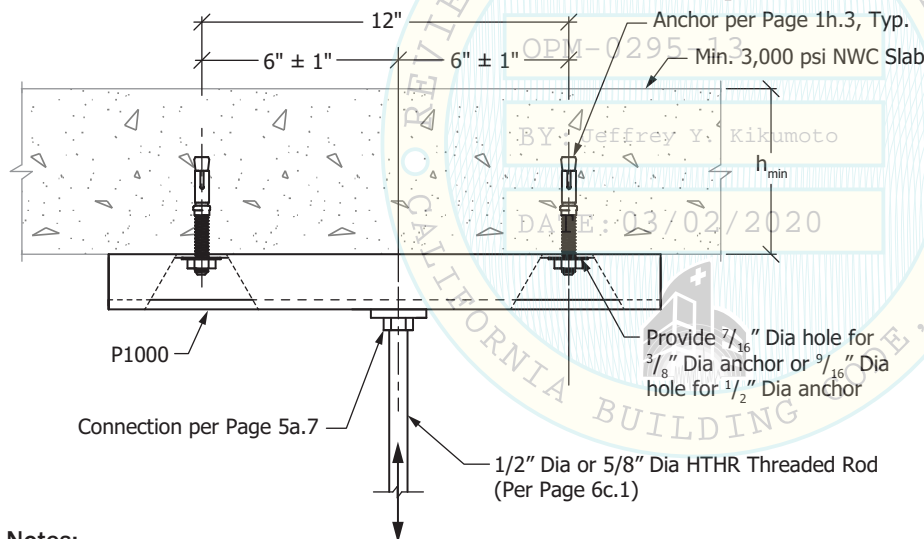

Maximum Tension Capacity (lbs.) ASD		
Anchor Diameter	3/8"	1/2"
Effective Embedment	2"	3 1/4"
h_{min}	4 1/2"	5"
With Seismic Load Effect ⁴	824	944
Without Seismic Load Effect	1,373	2,861

Notes:

- 1) See sheet 1h.3 for mechanical concrete anchor manufacturer information.
- 2) Design is controlled by seismic forces. Non-seismic forces such as gravity are outside the scope of this OPM.
- 3) Hanger Rod at seismic brace location is subjected to gravity loads as well as lateral and vertical seismic loads and has been designed for such combined loading in compliance with California Building Code, ASCE 7-10, and standard structural steel practices and are not subject to the hanger rod diameters designed for gravity loads only that may be outlined in project specifications, code documents, trade guidelines, etc. should adhere to the tables above.
- 4) Tension capacities with seismic load effect are ASD capacities increased by 1.2 including Ω_0 per ASCE 7-10 §12.4.3.

Atkore
Unistrut

16100 S. Lathrop Ave
Harvey, IL 60426
Toll-Free: (800) 882-5543

www.unistrutseismic.com

Rami Elhassan

Structural Engineer: Rami Elhassan
California SE No. 3930

Page:

7a.2

Post Installed Concrete Filled Metal Deck Connections

CONNECTIONS - EXPANSION ANCHORS INSTALLED IN UNDERSIDE OF SAND LWC OVER METAL DECK

DETAIL 7B.1-1: SINGLE EXPANSION ANCHOR

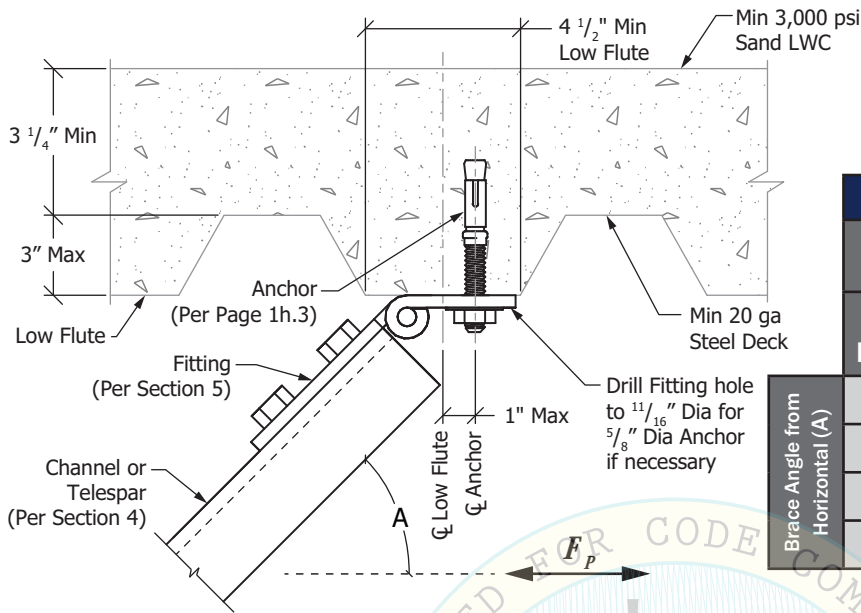

Maximum Horizontal F_p Force (lbs.)				
Anchor Diameter	1/2"		5/8"	
Effective Embedment	2 1/4"	3 1/4"	3 1/4"	4 1/4"
0° +5° / -0°	515	587	677	1,239
30° +5° / -25°	300	432	406	856
45° +5° / -10°	197	317	268	591
60° +0° / -10°	117	207	161	374

DETAIL 7B.1-2: TWO EXPANSION ANCHORS

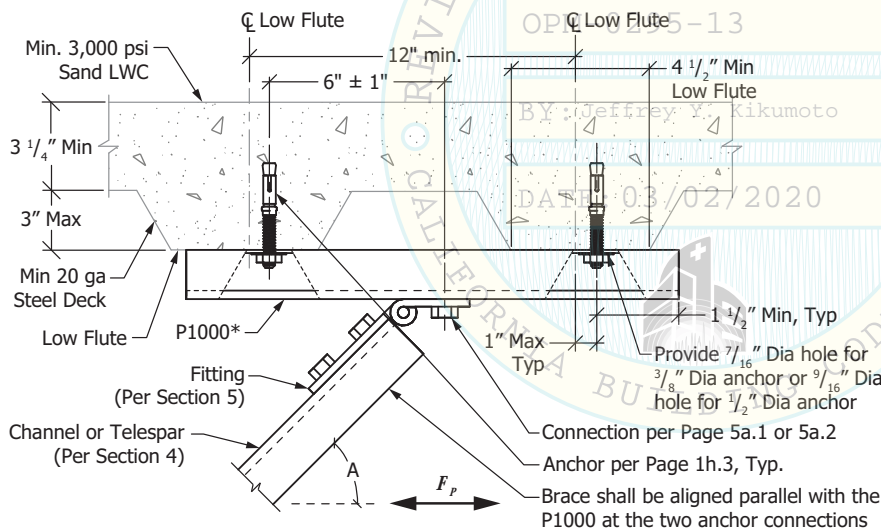

Maximum Horizontal F_p Force (lbs.)			
Anchor Diameter	3/8"	1/2"	
Effective Embedment	2"	2 1/4"	3 1/4"
0° +5° / -0°	747	1,029	1,173
30° +5° / -25°	489	578	815
45° +5° / -10°	367	416	623
60° +0° / -10°	256	280	442

Notes:

- 1) See sheet 1h.3 for mechanical concrete anchor manufacturer information.
- 2) * P1000T or P1000WT may be used in place of P1000 with a P3892-50 Wolf Washer at each 1/2" Ø expansion bolt (see Detail 5b.2-2) with F_p limited to 705 lbs.
- 3) F_p capacities on this page are ASD capacities increased by 1.2 including Ω_0 per ASCE 7-10 §12.4.3.3. For braces at a 0° angle, the F_p capacities listed are the allowable shear capacities of the anchors in concrete divided by Ω_0 .
- 4) These values apply only when using Unistrut brand products with the anchors listed on page 1h.3.



16100 S. Lathrop Ave
Harvey, IL 60426
Toll-Free: (800) 882-5543

www.unistrutseismic.com

Rami Elhassan

Structural Engineer: Rami Elhassan
California SE No. 3930

Page:

7b.1

Post Installed Concrete Filled Metal Deck Connections

CONNECTIONS - EXPANSION ANCHORS INSTALLED IN UNDERSIDE OF SAND LWC OVER METAL DECK

DETAIL 7B.2-1: SINGLE EXPANSION ANCHOR

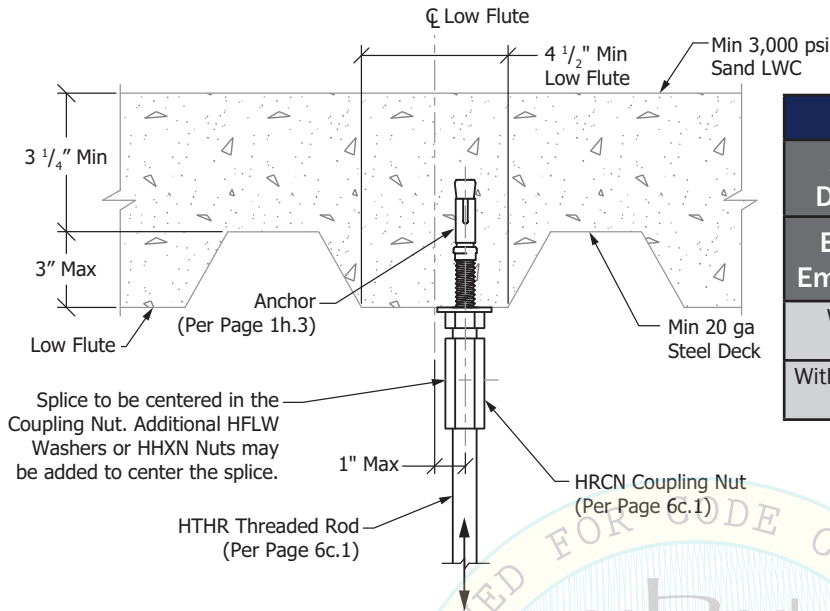

Maximum Tension Capacity (lbs.) ASD				
Anchor Diameter	3/8"	1/2"	5/8"	
Effective Embedment	2"	2 1/4"	3 1/4"	4 1/4"
With Seismic Load Effect ⁴	302	305	543	971
Without Seismic Load Effect	500	505	905	1,615

DETAIL 7B.2-2: TWO EXPANSION ANCHORS

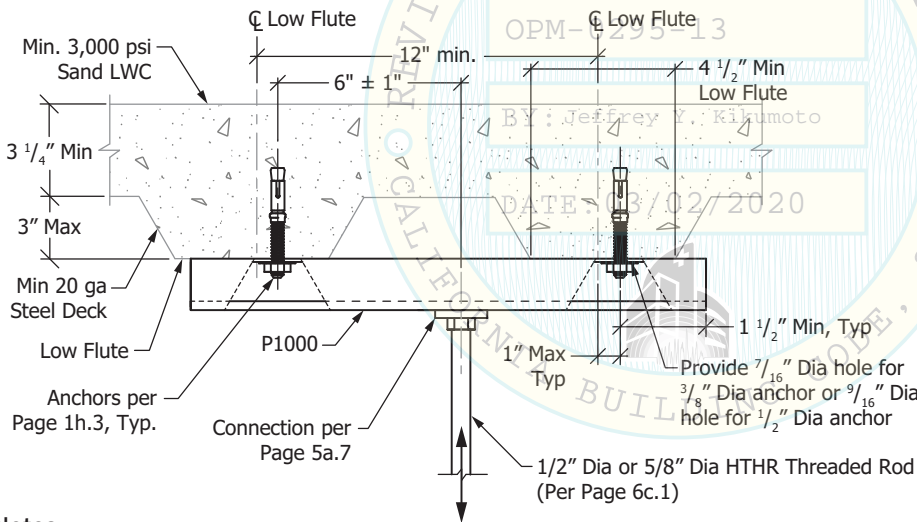

Maximum Tension Capacity (lbs.) ASD		
Anchor Diameter	3/8"	1/2"
Effective Embedment	2"	3 1/4"
With Seismic Load Effect ⁴	518	931
Without Seismic Load Effect	863	1,551

Notes:

- 1) See sheet 1h.3 for mechanical concrete anchor manufacturer information.
- 2) Design is controlled by seismic forces. Non-seismic forces such as gravity are outside the scope of this OPM.
- 3) Hanger Rod at seismic brace location is subjected to gravity loads as well as lateral and vertical seismic loads and has been designed for such combined loading in compliance with California Building Code, ASCE 7-10, and standard structural steel practices and are not subject to the hanger rod diameters designed for gravity loads only that may be outlined in project specifications, code documents, trade guidelines, etc. should adhere to the tables above.
- 4) Tension capacities with seismic load effect are ASD capacities increased by 1.2 including Ω_0 per ASCE 7-10 §12.4.3.

Atkore
Unistrut

16100 S. Lathrop Ave
Harvey, IL 60426
Toll-Free: (800) 882-5543

www.unistrutseismic.com

Rami Elhassan

Structural Engineer: Rami Elhassan
California SE No. 3930

Page:

7b.2

Steel Beam Connections

CONNECTIONS

DETAIL 7C.1-1: BOLT-THRU BEAM FLANGE

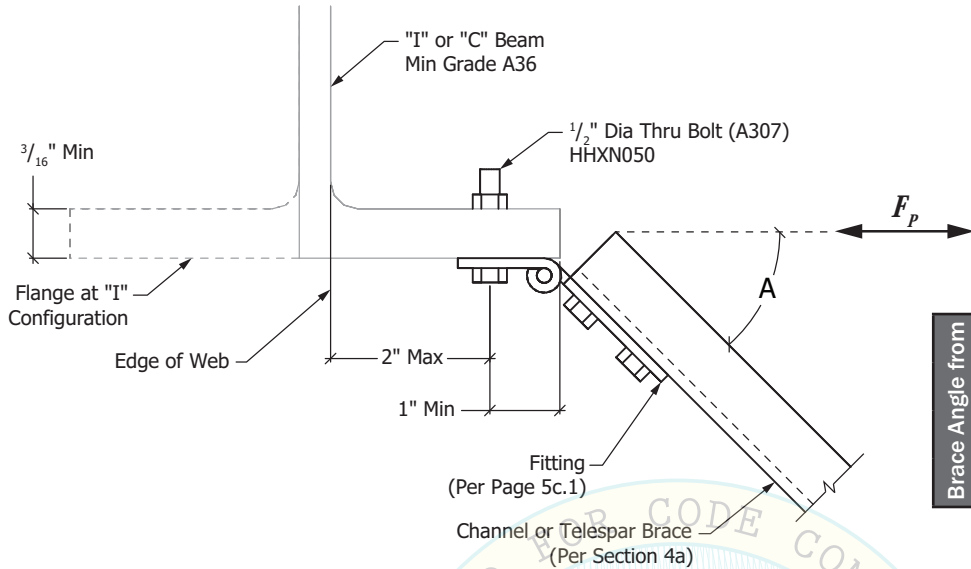

Brace Angle from Horizontal (A)	Maximum Horizontal F_P Force (lbs.) ASD	
	$0^\circ +5^\circ / -0^\circ$	2,135
$30^\circ +5^\circ / -25^\circ$	1,850	
$45^\circ +5^\circ / -10^\circ$	985	
$60^\circ +0^\circ / -10^\circ$	730	

DETAIL 7C.1-2: BOLT-THRU BEAM WEB

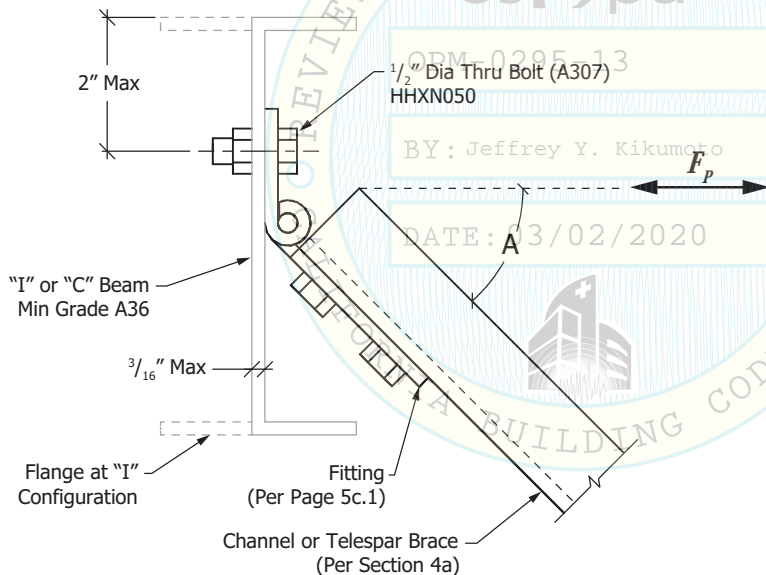

Brace Angle from Horizontal (A)	Maximum Horizontal F_P Force (lbs.) ASD	
	$90^\circ +0^\circ / -5^\circ$	-
$60^\circ +25^\circ / -5^\circ$	1,070	
$45^\circ +10^\circ / -5^\circ$	985	
$30^\circ +10^\circ / -0^\circ$	1,264	

Notes:

- 1) Brace can be located at any plan angle to beam when attached to flange.
- 2) Remove and reinstall fireproofing as needed to install fitting.

Atkore
Unistrut

16100 S. Lathrop Ave
Harvey, IL 60426
Toll-Free: (800) 882-5543

www.unistrutseismic.com

Structural Engineer: Rami Elhassan
California SE No. 3930

Page:

7c.1

Steel Beam Connections

CONNECTIONS

DETAIL 7C.2-1: WELD TO BEAM

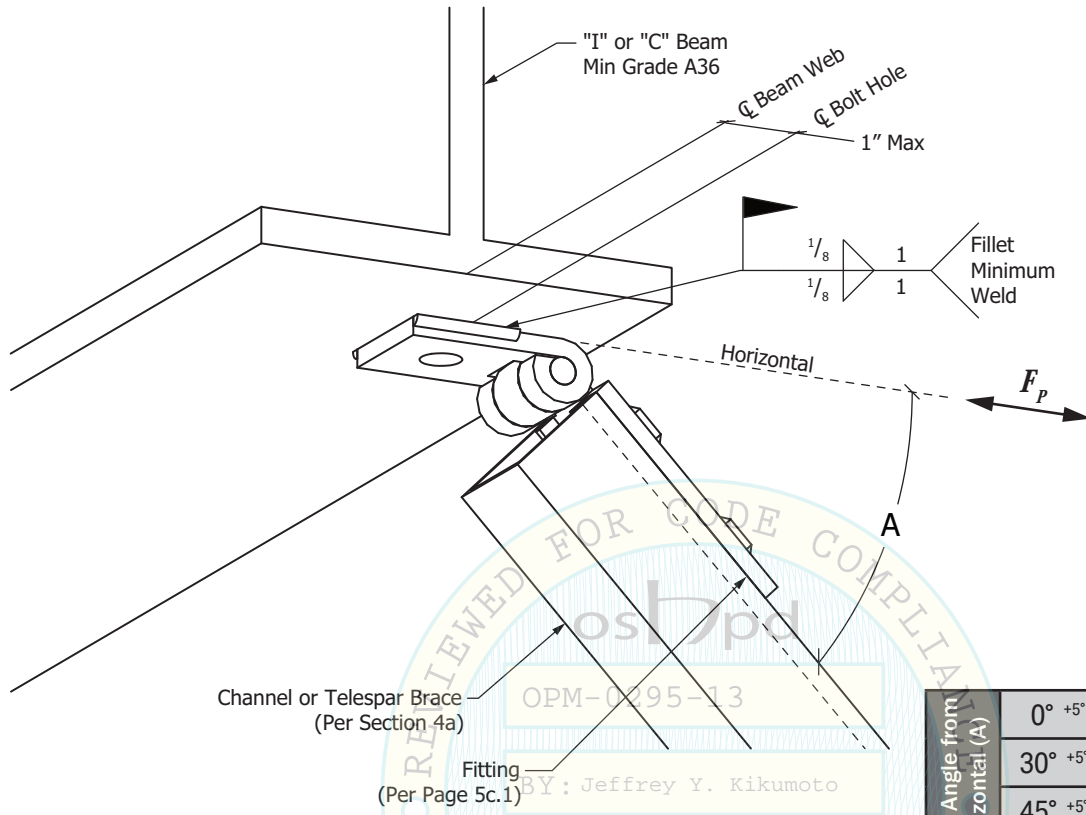

		Maximum Horizontal F_p Force (lbs.) ASD
Brace Angle from Horizontal (A)	0° +5° / -0°	2,135
	30° +5° / -25°	1,850
	45° +5° / -10°	985
	60° +0° / -10°	730

Notes:

- 1) Brace can be located at any plan angle to beam.
- 2) Remove and reinstall fireproofing as needed to install fitting.
- 3) Welded attachment to steel beam shall not be placed within the protected zone as defined in AISC 341.



16100 S. Lathrop Ave
Harvey, IL 60426
Toll-Free: (800) 882-5543

www.unistrutseismic.com

Rami Elhassan
Structural Engineer: Rami Elhassan
California SE No. 3930

Page:
7c.2

Wood Beam Connections

BRACE CONNECTION TO WOOD FRAMING

DETAIL 7D.1-1: BRACE PERPENDICULAR TO FRAMING

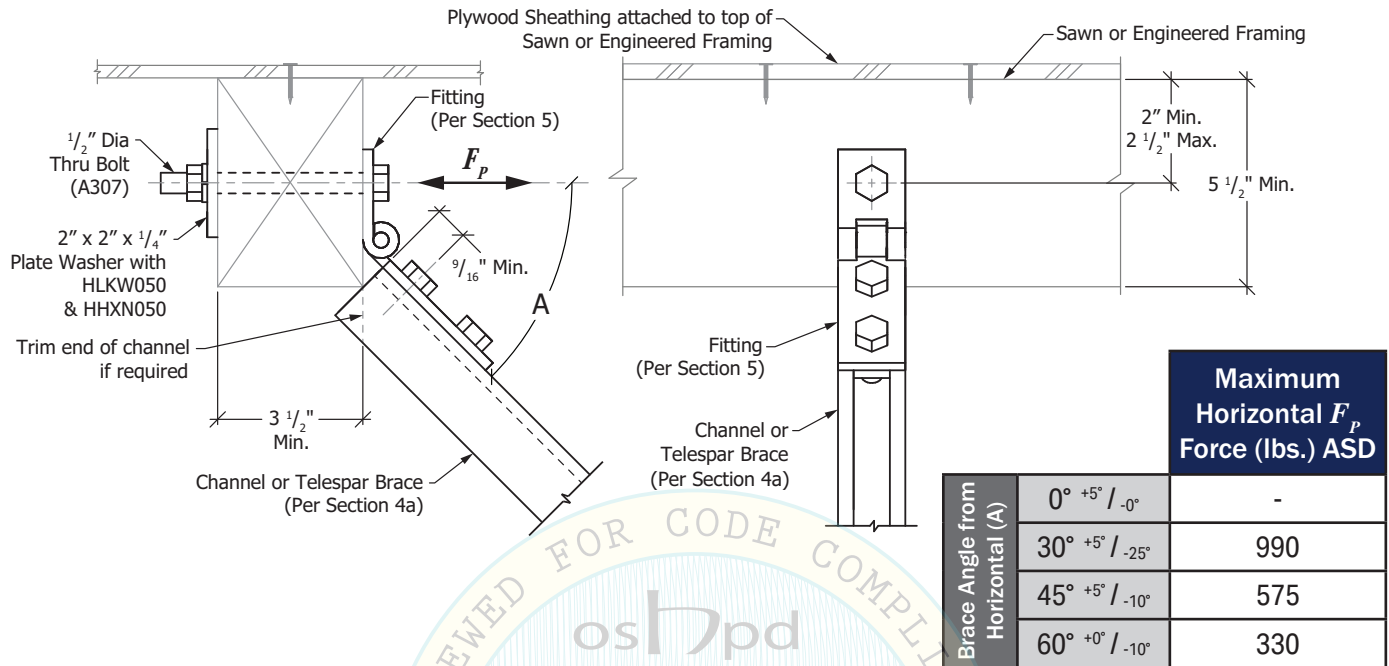

DETAIL 7D.1-2: BRACE PARALLEL TO WOOD FRAMING

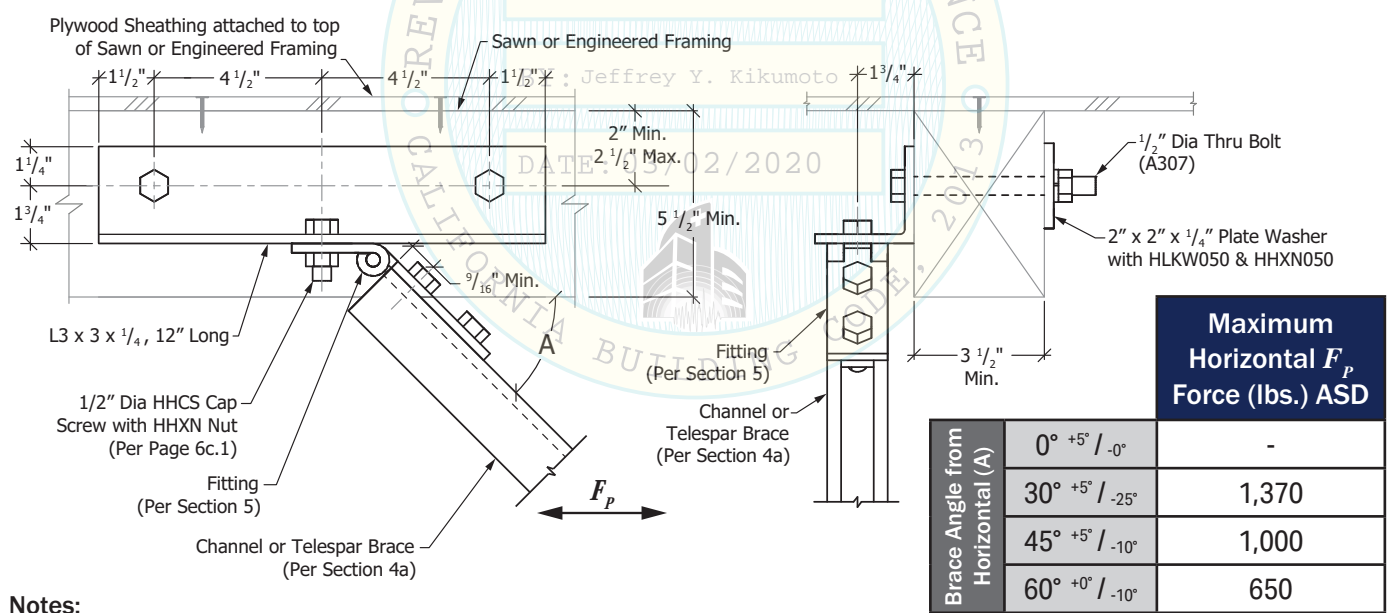

Notes:

- 1) Sawn or Engineered Framing shall be equivalent to Douglas Fir Larch #2 or better. Moisture content ≤ 19%.
- 2) Other detail components (e.g. fitting or brace) may limit system capacity if they have lower F_p force.



16100 S. Lathrop Ave
Harvey, IL 60426
Toll-Free: (800) 882-5543

www.unistrutseismic.com

Rami Elhassan
Structural Engineer: Rami Elhassan
California SE No. 3930

Page:

7d.1

Wood Beam Connections

CONNECTION TO WOOD FRAMING

DETAIL 7D.2-1: SUPPORT FROM FRAMING

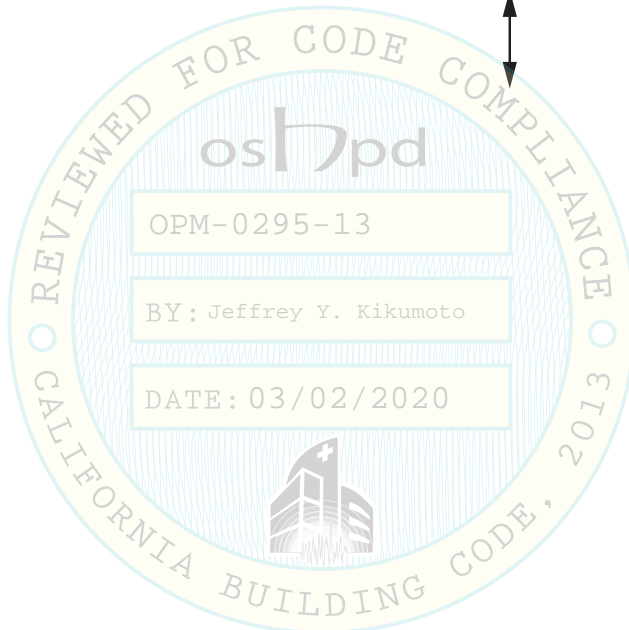
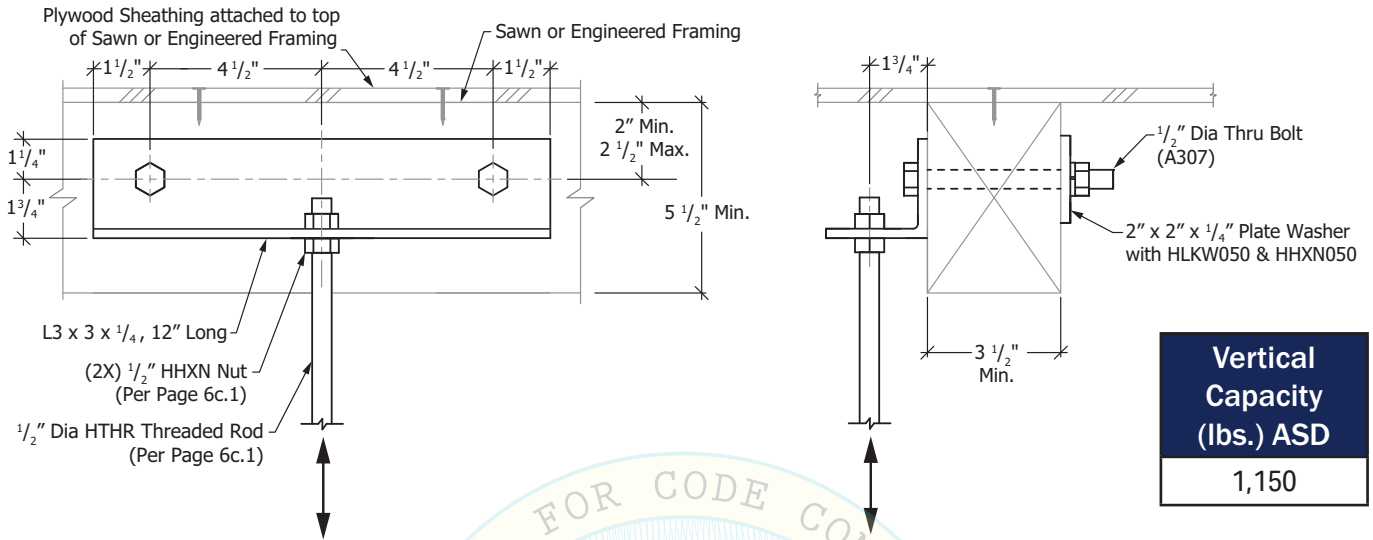

Notes:

- 1) Sawn or Engineered Framing shall be equivalent to Douglas Fir Larch #2 or better. Moisture \leq 19%.
- 2) $\frac{1}{2}$ " \varnothing Rod and Nuts at Fitting may be substituted with $\frac{1}{2}$ " \varnothing Cap Screw and Nut below Fitting with Coupling Nut and Threaded Rod.
- 3) See notes (1) and (2) on page 7a.0.

Atkore
Unistrut

16100 S. Lathrop Ave
Harvey, IL 60426
Toll-Free: (800) 882-5543

www.unistrutseismic.com

Rami Elhassan

Structural Engineer: Rami Elhassan
California SE No. 3930

Page:

7d.2

Design Examples

DESCRIPTION	PAGE
Single Pipe Seismic Restraint Design Example	8a.1 – 8a.6
Trapeze Supported Component(s) Seismic Restraint Design Example	8b.1 – 8b.7
Round Duct Seismic Restraint Design Example	8c.1 – 8c.5

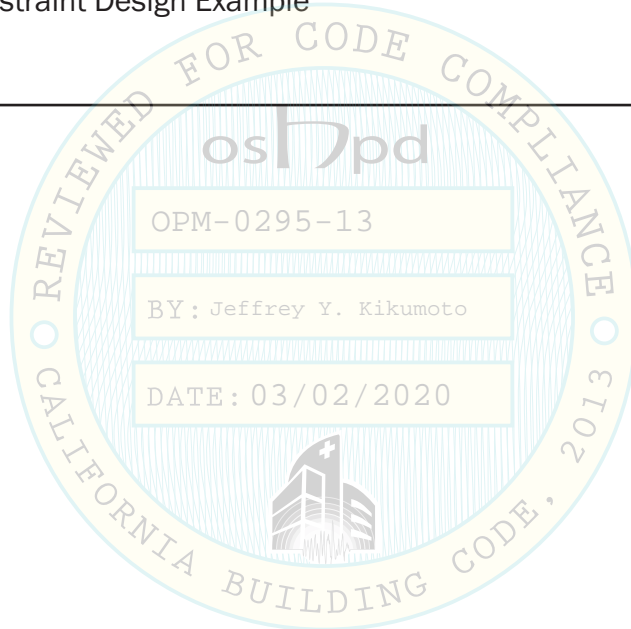

Atkore[™]
Unistrut

16100 S. Lathrop Ave
Harvey, IL 60426
Toll-Free: (800) 882-5543

www.unistrutseismic.com

Structural Engineer: Rami Elhassan
California SE No. 3930

Page:

8a.0

Single Pipe Seismic Restraint Design Example

SINGLE PIPE SEISMIC RESTRAINT DESIGN EXAMPLE

Example Scenario:

A 4" diameter schedule 40 steel pipe is being supported below the fourth floor of a seven story poured in-place concrete building. The floor and roof structure are comprised of a 10" thick concrete slab ($f'c = 4,000$ psi). The floor to floor height for each floor is 10'-0". The pipe is vertically supported at 10'-0" on center maximum. The short period spectral acceleration, S_{DS} , per the provided construct documents is 1.2. The component importance factor, $I_p = 1.5$.

Note: Reference Pages 3a.1 and 3a.2 for transverse and longitudinal bracing details.

Recommendation: Use 1/2" sized hanger rods and anchors wherever possible as there are more fittings available at this size.

Step 1: Determine F_p

Per ASCE 7-10 Table 13.6-1 (reference Page 1i.5):

$$a_p := 2.5 \quad R_p := 6 \quad \text{and} \quad \Omega_0 := 2.0$$

For piping in accordance with ASME B31, including in-line components, constructed of high or limited deformability materials, with joints made by threading, bonding, compression couplings, or grooved couplings.

$$\text{And} \quad S_{DS} := 1.2 \quad I_p := 1.5 \quad z := 30 \text{ ft} \quad h := 70 \text{ ft}$$

Per ASCE 7-10 Chapter 13, Eq 13.3-1 to 13.3-3 (reference Page 1i.2):

$$F_p(W_p) := \frac{0.4 a_p \cdot S_{DS} \cdot \left(1 + 2 \cdot \frac{z}{h}\right) \cdot W_p \cdot \frac{R_p}{I_p}}{\Omega_0} \rightarrow 0.56 \cdot W_p$$

F_p is not required to be taken as greater than

$$F_{pMax}(W_p) := 1.6 S_{DS} \cdot I_p \cdot W_p \rightarrow 2.88 \cdot W_p$$

(Per Page 1i.2)

and F_p shall not be taken as less than

$$F_{pMin}(W_p) := 0.3 S_{DS} \cdot I_p \cdot W_p \rightarrow 0.54 \cdot W_p$$

(Per Page 1i.2)

$$\text{Governing} \quad F_{pLRFD}(W_p) := F_p(W_p) \rightarrow 0.56 \cdot W_p$$

$$\text{And} \quad F_{pASD}(W_p) := 0.7 F_{pLRFD}(W_p) \rightarrow 0.39 \cdot W_p$$

$$\text{Whereas, the vertical seismic force } E_v, \quad E_{vLRFD}(W_p) := 0.2 S_{DS} \cdot W_p \rightarrow 0.24 \cdot W_p$$

$$\text{And} \quad E_{vASD}(W_p) := 0.7 E_{vLRFD}(W_p) \rightarrow 0.17 \cdot W_p$$

Atkore
Unistrut

16100 S. Lathrop Ave
Harvey, IL 60426
Toll-Free: (800) 882-5543

www.unistrutseismic.com



Structural Engineer: Rami Elhassan
California SE No. 3930

Page:

8a.1

Single Pipe Seismic Restraint Design Example

SINGLE PIPE SEISMIC RESTRAINT DESIGN EXAMPLE (CONTINUED...)

Step 2: Determine Weight of Pipe W_p

Per OPM Appendix Page A1.1, the self weight of a 4" diameter insulated schedule 40 pipe filled with water, including fitting allowance of 15% pipe weight ($1.15 \times 10.8 + 5.5 + 1.8 = 19.7$ plf).

$$W_p(l_{trib}) := 19.7 \text{plf} \cdot l_{trib}$$

Step 3: Determine Seismic and Gravity Forces

Seismic force at each transverse brace:

Per OPM Page 1m.1, the maximum span for a 4" diameter insulated schedule 40 pipe when $F_{pASD} = 0.39 W_p < 0.5 W_p$ is 37'-0", use 30'-0". $l_T := 30 \text{ ft}$.

Thus $W_p(l_T) = 591 \text{ lbf}$ and

$$F_{pASD}(W_p(l_T)) = 230.5 \text{ lbf}$$

Gravity and vertical seismic forces at the vertical hanger connection with a brace:

$$l_v := 10 \text{ ft} \quad (\text{Vertical hangers are spaced at } 10'-0" \text{ on center})$$

$$W_p(l_v) = 197 \text{ lbf}$$

$$E_{vASD}(W_p(l_v)) = 33.5 \text{ lbf}$$

θ is the brace angle from horizontal at the vertical hanger. Choose a brace angle of 45°.

$$\theta := 45^\circ$$

Maximum tension in vertical hanger T_{Vert}

$$T_{Vert} := \underbrace{W_p(l_v)}_{\text{Gravity Weight}} + \underbrace{E_{vASD}(W_p(l_v))}_{\text{Vertical Seismic Force}} + \underbrace{F_{pASD}(W_p(l_T)) \cdot \tan(\theta)}_{\text{Vertical Force from Horizontal Seismic Force Through Brace}} = 461 \text{ lbf}$$

Maximum compression in vertical hanger C_{Vert}

$$C_{Vert} := (-0.6) W_p(l_v) + E_{vASD}(W_p(l_v)) + F_{pASD}(W_p(l_T)) \cdot \tan(\theta) = 145.8 \text{ lbf}$$

For anchorage design where Ω_0 is required by governing code:

$$T_{Vert\Omega_0} := W_p(l_v) + E_{vASD}(W_p(l_v)) + \Omega_0 \cdot F_{pASD}(W_p(l_T)) \cdot \tan(\theta) = 691.5 \text{ lbf}$$

Step 4: Determine attachment to structure per Section 7.

As stated above, the supporting structure is a 10" thick concrete slab.

Per OPM Page 7a.1: Single (1) 1/2" diameter expansion anchor with 3 1/4" embedment is acceptable for a maximum horizontal F_{pASD} force = 612 lbf.

$$F_{pASD}(W_p(l_T)) = 230.5 \text{ lbf} < 612 \text{ lbf. Therefore OK at brace. } \checkmark$$

Atkore
Unistrut

16100 S. Lathrop Ave
Harvey, IL 60426
Toll-Free: (800) 882-5543

www.unistrutseismic.com



Structural Engineer: Rami Elhassan
California SE No. 3930

Page:

8a.2

Single Pipe Seismic Restraint Design Example

SINGLE PIPE SEISMIC RESTRAINT DESIGN EXAMPLE (CONTINUED...)

Per OPM Page 1h.4: Single (1) 1/2" diameter expansion anchor with 3 1/4" embedment is acceptable for a maximum vertical $T_{Vert\Omega_0}$ force = 2,003 lbf.

$$T_{Vert\Omega_0} = 691.5 \text{ lbf} < 2,003 \text{ lbf. Therefore OK at hanger. } \checkmark$$

Step 5: Determine brace member, fittings and connections per Sections 4 & 5.

Braces to be at $\theta := 45^\circ$ Try **P3810-050** for the brace fitting.

Per OPM Page 5c.1: A **P3810-050** fitting is acceptable for a maximum horizontal F_{pASD} force = 985 lbf.

$$F_{pASD} (W_p (I_T)) = 230.5 \text{ lbf} < 985 \text{ lbf. Therefore OK at brace. } \checkmark$$

The pipe will be supported 4'-0" maximum from support structure. Provide lateral braces at $\theta = 45^\circ$.

Therefore, the maximum lateral brace length is approximately $\frac{4 \text{ ft}}{\cos(\theta)} = 5.657 \text{ ft}$ use 6'-0".

Try **P1000** for the brace member. Per OPM Page 4a.1: A **P1000** at a max length of 6'-0" is acceptable for a maximum horizontal F_{pASD} force = 1,470 lbf.

$$F_{pASD} (W_p (I_T)) = 230.5 \text{ lbf} < 1,470 \text{ lbf. Therefore OK at brace. } \checkmark$$

For the connection of the brace fitting to the channel beam, try Detail 5a.2-1. Per OPM Page 5a.2: The connection is acceptable for a maximum horizontal F_{pASD} force = 2,375 lbf [use "Slip Resistance" F_p for transverse brace].

$$F_{pASD} (W_p (I_T)) = 230.5 \text{ lbf} < 2,375 \text{ lbf. Therefore OK at brace. } \checkmark$$

Step 6: Determine Pipe Clamp per Section 5.

Per OPM Page 5d.1, the **P1121** (4") Pipe Clamp is acceptable for a maximum horizontal F_{pASD} force = 360 lbf [C_T for transverse] and a T_{Vert} force = 2,090 lbf [C_V for vertical].

$$F_{pASD} (W_p (I_T)) = 230.5 \text{ lbf} < 360 \text{ lbf. Therefore OK at brace. } \checkmark$$

$$T_{Vert} = 461 \text{ lbf} < 2,090 \text{ lbf. Therefore OK at brace. } \checkmark$$

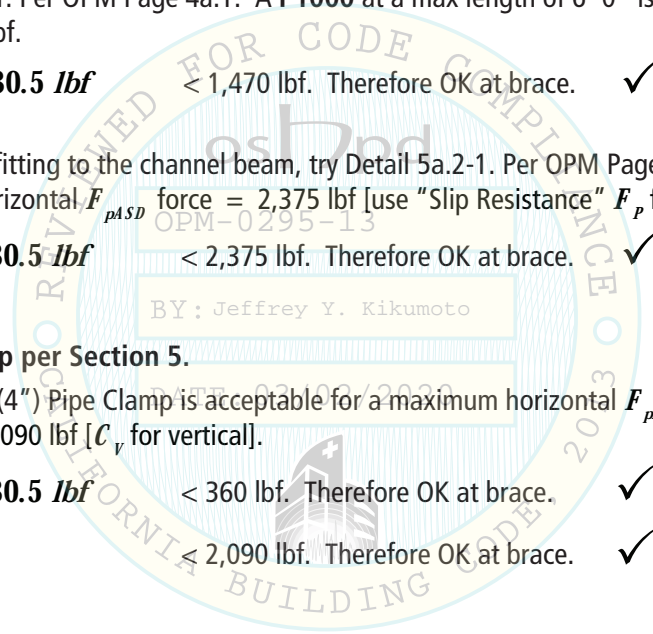

<p style="font-size: small; margin-top: 10px;">16100 S. Lathrop Ave Harvey, IL 60426 Toll-Free: (800) 882-5543</p> <p style="font-size: x-small; margin-top: 5px;">www.unistrutseismic.com</p>		Page:
	Structural Engineer: Rami Elhassan California SE No. 3930	8a.3

Single Pipe Seismic Restraint Design Example

SINGLE PIPE SEISMIC RESTRAINT DESIGN EXAMPLE (CONTINUED...)

Step 7: Determine vertical hanger rod, stiffener and connection to channel per Sections 5 & 6.

For connecting Rod to Channel, try Detail 5a.7-1. Per OPM Page 5a.7: The connection is acceptable for a maximum vertical T_{Vert} or C_{Vert} force = 2,065 lbf when used with a 1/2" threaded rod and a Wolf Washer (Per Table 5a.7-2).

Note: This capacity also includes the vertical capacity of the back-to-back channel as shown on Pages 3a.1 and 5a.7.

$$T_{Vert} = 461 \text{ lbf} \quad \text{and} \quad C_{Vert} = 145.8 \text{ lbf} \quad < 2,065 \text{ lbf. Therefore OK at brace.} \quad \checkmark$$

Per OPM Page 6d.2 Note 1, the length of the threaded rod (4 ft) exceeds 30", thus Rod Stiffeners are required.

Per OPM Page 6d.3, the maximum acceptable compression force for a 1/2" diameter rod with stiffener and bolt spacing at 24" and maximum rod length not exceeding 13.0', $F_{pASD} = 338 \text{ lbf}$.

$$F_{pASD} (W_p (I_T)) = 230.5 \text{ lbf} \quad < 338 \text{ lbf. Therefore OK at brace.} \quad \checkmark$$

Therefore, a rod stiffener is required with a clip spacing (L) of 24" maximum.

Example Notes:

If the capacity is exceeded at Steps 4 through 7, the design should be modified such that braces are spaced closer and the demand force is reduced to meet ALL of the brace component capacities.

Step 8: Continue to design for longitudinal braces.

Continue to design the longitudinal braces, following steps similar to Steps 3 through 7.

Seismic force at each longitudinal brace:

Use a longitudinal brace spacing of $I_L := 60 \text{ ft}$

Thus $W_p (I_L) = 1,182 \text{ lbf}$ and

$$F_{pASD} (W_p (I_L)) = 461 \text{ lbf}$$

Gravity and vertical seismic forces at the vertical hanger connection with a brace:

$I_v := 10 \text{ ft}$ (Vertical hangers are spaced at 10'-0" on center)

$$W_p (I_v) = 197 \text{ lbf}$$

$$E_{vASD} (W_p (I_v)) = 33.5 \text{ lbf}$$

θ is the brace angle from horizontal at the vertical hanger. Choose a brace angle of 45°.

$$\theta_L := 45^\circ$$

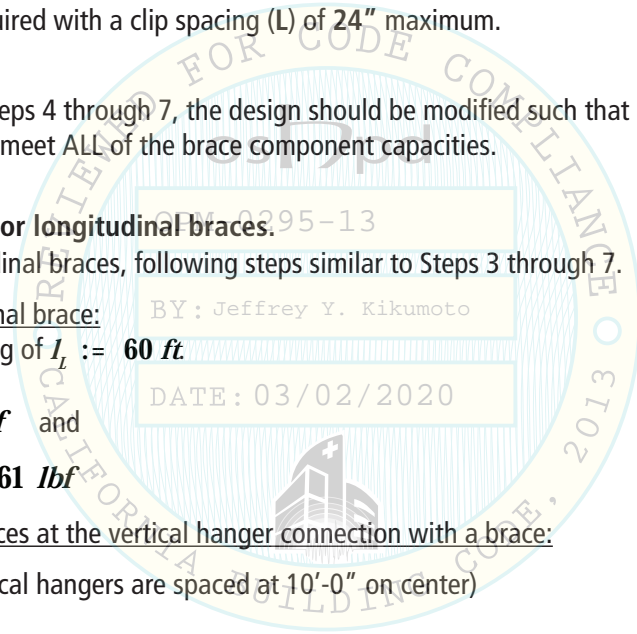

<p style="font-size: small; margin-top: 10px;">16100 S. Lathrop Ave Harvey, IL 60426 Toll-Free: (800) 882-5543</p> <p style="font-size: x-small; text-align: center;">www.unistrutseismic.com</p>		Page: <h2 style="margin: 0;">8a.4</h2>
	Structural Engineer: Rami Elhassan California SE No. 3930	

Single Pipe Seismic Restraint Design Example

SINGLE PIPE SEISMIC RESTRAINT DESIGN EXAMPLE (CONTINUED...)

Maximum tension in vertical hanger T_{Vert}

$$T_{LVert} := \underbrace{W_p(I_v)}_{\text{Gravity Weight}} + \underbrace{E_{vASD}(W_p(I_v))}_{\text{Vertical Seismic Force}} + \underbrace{F_{pASD}(W_p(I_L)) \cdot \tan(\theta)}_{\text{Vertical Force from Horizontal Seismic Force Through Brace}} = 691.5 \text{ lbf}$$

Maximum compression in vertical hanger C_{Vert}

$$C_{LVert} := (-0.6) W_p(I_v) + E_{vASD}(W_p(I_v)) + F_{pASD}(W_p(I_L)) \cdot \tan(\theta) = 376.3 \text{ lbf}$$

For anchorage design where Ω_0 is required by governing code:

$$T_{LVer\Omega_0} := W_p(I_v) + E_{vASD}(W_p(I_v)) + \Omega_0 \cdot F_{pASD}(W_p(I_L)) \cdot \tan(\theta) = 1,152.5 \text{ lbf}$$

Determine attachment to structure per Section 7.

As stated above, the supporting structure is a 10" thick concrete slab.

Per OPM Page 7a.1: Single (1) 1/2" diameter expansion anchor with 3 1/4" embedment is acceptable for a maximum horizontal F_{pASD} force = 612 lbf.

$$F_{pASD}(W_p(I_L)) = 461 \text{ lbf} < 612 \text{ lbf. Therefore OK at brace. } \checkmark$$

Per OPM Page 1h.4 Table 3: Single (1) 1/2" diameter expansion anchor with 3 1/4" embedment is acceptable for a maximum vertical $T_{Ver\Omega_0}$ force = 2,003 lbf.

$$T_{LVer\Omega_0} = 1,152.5 \text{ lbf} < 2,003 \text{ lbf. Therefore OK at hanger. } \checkmark$$

Determine brace member, fittings and connections per Sections 4 & 5.

Choose a single longitudinal brace, attached at the threaded rod connection to the horizontal channel. Reference page 3a.2.

Braces to be at $\theta := 45^\circ$ Try **P3810-050** for the brace fitting. 20

Per OPM Page 5c.1: A **P3810-050** fitting is acceptable for a maximum horizontal F_{pASD} force = 985 lbf.

$$F_{pASD}(W_p(I_L)) = 461 \text{ lbf} < 985 \text{ lbf. Therefore OK at brace. } \checkmark$$

Try **P1000** for the brace member. Per OPM Page 4a.1: A **P1000** at a max length of 6'-0" is acceptable for a maximum horizontal F_{pASD} force = 1,470 lbf.

$$F_{pASD}(W_p(I_L)) = 461 \text{ lbf} < 1,470 \text{ lbf. Therefore OK at brace. } \checkmark$$

For the connection of the brace fitting to the channel beam, try Detail 5a.4-1, which includes the threaded rod connection.

Per OPM Page 5a.4: The 1/2" connection is acceptable for a maximum horizontal F_{pASD} force = 640 lbf [use "Perpendicular" F_p for longitudinal brace] where the brace is attached to the opposite side of the strut from the pipe.

$$F_{pASD}(W_p(I_L)) = 461 \text{ lbf} < 640 \text{ lbf. Therefore OK at brace. } \checkmark$$

Note: This capacity also includes the vertical capacity of the back-to-back channel as shown on Pages 3a.1 and 5a.2.

Atkore
Unistrut

16100 S. Lathrop Ave
Harvey, IL 60426
Toll-Free: (800) 882-5543

www.unistrutseismic.com



Structural Engineer: Rami Elhassan
California SE No. 3930

Page:

8a.5

Single Pipe Seismic Restraint Design Example

SINGLE PIPE SEISMIC RESTRAINT DESIGN EXAMPLE (CONTINUED...)

Determine Pipe Clamp per Section 5.

Per OPM Page 5d.1, the P1121 (4") Pipe Clamp is acceptable for a maximum horizontal F_{pASD} force = 730 lbf [C_L for longitudinal] and a T_{vert} force = 2,090 lbf [C_V for vertical].

$$F_{pASD} (W_P (I_L)) = 461 \text{ lbf} < 730 \text{ lbf. Therefore OK at brace. } \checkmark$$

$$T_{vert} = 691.5 \text{ lbf} < 2,090 \text{ lbf. Therefore OK at brace. } \checkmark$$

Determine vertical hanger rod, stiffener and connection to channel per Sections 5 & 6.

For connecting Rod to Channel, Detail 5a.4-1 was selected on the previous page. Per OPM Page 5a.4: The connection is acceptable for a maximum vertical T_{vert} or C_{vert} force = 2,065 lbf when used with a 1/2" threaded rod.

Note: This capacity also includes the vertical capacity of the back-to-back channel as shown on Pages 3a.1 and 5a.7.

$$T_{vert} = 691.5 \text{ lbf} \quad \text{and} \quad C_{LVert} = 376.3 \text{ lbf} < 2,065 \text{ lbf. Therefore OK at brace. } \checkmark$$

Per OPM Page 6d.2 Note 1, the length of the threaded rod (4 ft) exceeds 30", thus Rod Stiffeners are required.

Per OPM Page 6d.3, the maximum acceptable compression force for a 1/2" diameter rod with stiffener and bolt spacing at 24" and maximum rod length not exceeding 13.0', $F_{pASD} = 338$ lbf.

$$F_{pASD} (W_P (I_L)) = 461 \text{ lbf} > 338 \text{ lbf. Therefore not OK at brace. } \times$$

Since the above stiffener and bolt spacing did not have enough capacity, reevaluate with a shorter spacing.

Per OPM Page 6d.3, the maximum acceptable compression force for a 1/2" diameter rod with stiffener and bolt spacing at 18" and maximum rod length not exceeding 9.8', $F_{pASD} = 601$ lbf.

$$F_{pASD} (W_P (I_L)) = 461 \text{ lbf} < 601 \text{ lbf. Therefore OK at brace. } \checkmark$$

Therefore, a rod stiffener is required with a clip spacing (L) of 18" maximum at the longitudinal brace locations. This spacing can also be used at the transverse brace locations as determined in Step 7, since the 601 lbf capacity exceeds the 245.86 lbf load.

Example Notes:

If the capacity is exceeded at Step 8, the design should be modified such that braces are spaced closer and the demand force is reduced to meet ALL of the brace component capacities.

Atkore
Unistrut

16100 S. Lathrop Ave
Harvey, IL 60426
Toll-Free: (800) 882-5543

www.unistrutseismic.com

Rami Elhassan
Structural Engineer: Rami Elhassan
California SE No. 3930

Page:

8a.6

Trapeze Supported Component(s) Seismic Restraint Design Example

TRAPEZE SUPPORTED COMPONENT(S) SEISMIC RESTRAINT DESIGN EXAMPLE

Note: This procedure can be used to brace pipe, conduit, tube, cable tray or duct supported by a trapeze. Where applicable, commentary has been provided throughout this procedure for systems not used in the example scenario.

Example Scenario:

Two (2) - 4" diameter schedule 40 steel pipes and one (1) - 6" diameter schedule 40 steel pipe are being supported with trapeze below the fourth floor of a seven story poured in-place concrete building. The floor and roof structure are comprised of a 10" thick concrete slab ($f'c = 4,000$ psi). The floor to floor height for each floor is 10'-0". The pipe is vertically supported at 10'-0" on center maximum. The short period spectral acceleration, S_{DS} , per the provided construct documents is 1.2. The component importance factor is, $I_p = 1.5$.

Note: Reference Section 3 for transverse and longitudinal bracing details (Pages 3c.1 and 3c.2 used in this example).

For pipe, conduit and tube, refer to pages 3c.1 & 3c.2

For rectangular duct, refer to pages 3d.1 & 3d.2

For cable tray, refer to pages 3f.1 & 3f.2

Recommendation: Use 1/2" sized hanger rods and anchors wherever possible as there are more fittings available at this size.

Step 1: Determine F_p

Per ASCE 7-10 Table 13.6-1 (reference Page 1i.5):

$$a_p := 2.5 \quad R_p := 6 \quad \text{and} \quad \Omega_0 := 2.0$$

For piping in accordance with ASME B31, including in-line components, constructed of high or limited deformability materials, with joints made by threading, bonding, compression couplings, or grooved couplings.

And $S_{DS} := 1.2 \quad I_p := 1.5 \quad z := 30 \text{ ft} \quad h := 70 \text{ ft}$

Per ASCE 7-10 Chapter 13, Eq 13.3-1 to 13.3-3 (reference Page 1i.2):

$$F_p(W_p) := \frac{0.4 a_p \cdot S_{DS} \cdot \left(1 + 2 \cdot \frac{z}{h}\right) \cdot W_p}{\frac{R_p}{I_p}} \rightarrow 0.56 \cdot W_p$$

F_p is not required to be taken as greater than

(Per Page 1i.2)

$$F_{pMax}(W_p) := 1.6 S_{DS} \cdot I_p \cdot W_p \rightarrow 2.88 \cdot W_p$$

and F_p shall not be taken as less than

(Per Page 1i.2)

$$F_{pMin}(W_p) := 0.3 S_{DS} \cdot I_p \cdot W_p \rightarrow 0.54 \cdot W_p$$



16100 S. Lathrop Ave
Harvey, IL 60426
Toll-Free: (800) 882-5543

www.unistrutseismic.com

Structural Engineer: Rami Elhassan
California SE No. 3930

Page:

8b.1

Trapeze Supported Component(s) Seismic Restraint Design Example

TRAPEZE SUPPORTED COMPONENT(S) SEISMIC RESTRAINT DESIGN EXAMPLE (CONTINUED...)

Governing $F_{pLRFD}(W_p) := F_p(W_p) \rightarrow 0.56 \cdot W_p$

And $F_{pASD}(W_p) := 0.7 F_{pLRFD}(W_p) \rightarrow 0.39 \cdot W_p$

Whereas, the vertical seismic force E_v , $E_{vLRFD}(W_p) := 0.2 S_{DS} \cdot W_p \rightarrow 0.24 \cdot W_p$

And $E_{vASD}(W_p) := 0.7 E_{vLRFD}(W_p) \rightarrow 0.17 \cdot W_p$

Step 2: Determine Weight of Pipes W_p

Per OPM Appendix Page A1.1, the self weight of a 4" diameter insulated schedule 40 pipe filled with water, including fitting allowance of 15% pipe weight is 18.2 plf, and that of an 6" diameter schedule 40 pipe filled with water is 34.9 plf. Therefore, the weight of the three pipes together is,

$$W_p(I_{trib}) := (2 \times 18.2 + 34.9) \text{ plf} \cdot I_{trib} \rightarrow 71.3 \cdot I_{trib} \text{ plf}$$

Note: Reference Appendix Section A1 for self weights of all components.

For steel pipe, reference pages A1.1 & A1.2

For copper pipe and tube, reference page A1.3

For electrical conduit, reference page A1.4

For cable tray, reference page A1.4

For rectangular duct, reference pages A1.5-A1.7

Step 3: Determine Seismic and Gravity Forces

Seismic force at each transverse brace:

For multiple pipes supported by a trapeze, the maximum spacing of the lateral braces is controlled by the one with the least spanning capacity, which is the 4" pipe in this example. Per OPM Page 1m.1, the maximum span for a 4" diameter insulated schedule 40 pipe when $F_{pASD} = 0.39 W_p < 0.5 W_p$ is 37'-0". However, considering the anchorage capacity, a 20'-0" spacing is chosen.

Thus $I_T := 20 \text{ ft}$ and $W_p(I_T) = 1,426 \text{ lbf}$

$$F_{pASD}(W_p(I_T)) = 556.1 \text{ lbf}$$

- Note:
- 1) For no-hub cast iron pipes: Follow transverse and longitudinal brace spacing and other guidance on page 1i.2, note 7.
 - 2) For cable trays: Cable trays shall be approved on a project specific basis, or preapproved by OSHPD. Spacing limits set by the manufacturer shall not be exceeded. Cable tray brace spacing shall be approved or preapproved by OSHPD.
 - 3) For rectangular duct: Follow transverse and longitudinal brace spacing guidance provided on page 1i.3, note 8.

Atkore
Unistrut

16100 S. Lathrop Ave
Harvey, IL 60426
Toll-Free: (800) 882-5543

www.unistrutseismic.com



Structural Engineer: Rami Elhassan
California SE No. 3930

Page:

8b.2

Trapeze Supported Component(s) Seismic Restraint Design Example

TRAPEZE SUPPORTED COMPONENT(S) SEISMIC RESTRAINT DESIGN EXAMPLE (CONTINUED...)

Gravity and vertical seismic forces at the vertical hanger connection with a brace:

Two (2) - vertical hangers are spaced at 10'-0" on center, each vertical hanger is assumed to resist 2/3 of the pipe weight based on actual eccentricity. Therefore,

$$I_v := 10 \text{ ft} \cdot \frac{2}{3} = 6.67 \text{ ft} \quad \text{and} \quad W_p(I_v) = 475.6 \text{ lbf}$$

$$E_{vASD}(W_p(I_v)) = 80.8 \text{ lbf}$$

θ is the brace angle from horizontal at the vertical hanger. Choose a brace angle of 45°.

$$\theta := 45^\circ$$

Maximum tension in vertical hanger T_{vert}

$$T_{vert} := \frac{W_p(I_v)}{\text{Gravity Weight}} + \frac{E_{vASD}(W_p(I_v))}{\text{Vertical Seismic Force}} + \frac{F_{pASD}(W_p(I_T)) \cdot \tan(\theta)}{\text{Vertical Force from Horizontal Seismic Force Through Brace}} = 1,112.5 \text{ lbf}$$

Maximum compression in vertical hanger C_{vert}

$$C_{vert} := (-0.6) W_p(I_v) + E_{vASD}(W_p(I_v)) + F_{pASD}(W_p(I_T)) \cdot \tan(\theta) = 351.5 \text{ lbf}$$

For anchorage design where Ω_0 is required by governing code:

$$T_{Ver\Omega_0} := W_p(I_v) + E_{vASD}(W_p(I_v)) + \Omega_0 \cdot F_{pASD}(W_p(I_T)) \cdot \tan(\theta) = 1,668.6 \text{ lbf}$$

Step 4: Determine attachment to structure per Section 7. Kikumoto

As stated above, the supporting structure is a 10" thick concrete slab.

Per OPM Page 7a.1: Two (2) 1/2" diameter expansion anchors with 3 1/4" embedments at 12" O.C. are acceptable for a maximum horizontal F_{pASD} force = 1,239 lbf. DATE: 03/02/2020

$$F_{pASD}(W_p(I_T)) = 556.1 \text{ lbf} < 1,239 \text{ lbf. Therefore OK at brace.} \quad \checkmark$$

Per OPM Page 1h.4, Table 3: A single (1) 5/8" diameter expansion anchor with a 4 1/4" embedment is acceptable for a maximum vertical $T_{Ver\Omega_0}$ force = 3,113 lbf.

$$T_{Ver\Omega_0} = 1,668.6 \text{ lbf} < 3,113 \text{ lbf. Therefore OK at the hanger connected to a hanger.} \quad \checkmark$$

Step 5: Determine brace member, fittings and connections per Sections 4 & 5.

Braces to be at $\theta := 45^\circ$ Try a P3810-050 for the brace fitting.

Per OPM Page 5c.1: A P3810-050 fitting is acceptable for a maximum horizontal F_{pASD} force = 985 lbf.

$$F_{pASD}(W_p(I_T)) = 556.1 \text{ lbf} < 985 \text{ lbf. Therefore OK at brace.} \quad \checkmark$$

Atkore
Unistrut

16100 S. Lathrop Ave
Harvey, IL 60426
Toll-Free: (800) 882-5543

www.unistrutseismic.com



Structural Engineer: Rami Elhassan
California SE No. 3930

Page:

8b.3

Trapeze Supported Component(s) Seismic Restraint Design Example

TRAPEZE SUPPORTED COMPONENT(S) SEISMIC RESTRAINT DESIGN EXAMPLE (CONTINUED...)

The pipe will be supported 4'-0" maximum from support structure. Provide lateral braces at $\theta = 45^\circ$.

Therefore, the maximum lateral brace length is approximately $\frac{4 \text{ ft}}{\cos(\theta)} = 5.657 \text{ ft}$, use 6'-0".

Try **P1000** for the brace member. Per OPM Page 4a.1: A **P1000** at a max length of 6'-0" is acceptable for a maximum horizontal F_{pASD} force = 1,470 lbf.

$$F_{pASD} (W_p (L_T)) = 556.1 \text{ lbf} < 1,470 \text{ lbf. Therefore OK at brace. } \checkmark$$

For the connection of the brace fitting to the channel beam, try Detail 5a.2-1 where the brace will be attached adjacent to the rod since a 5/8" rod is being used. Per OPM Page 5a.2: The connection is acceptable for a maximum horizontal F_{pASD} force = 2,375 lbf [use "Slip Resistance" F_p for transverse brace].

$$F_{pASD} (W_p (L_T)) = 556.1 \text{ lbf} < 2,375 \text{ lbf. Therefore OK at brace. } \checkmark$$

Step 6: Determine Pipe Clamps per Section 5.

Select a Pipe Clamp for the 6" Pipe. Per OPM Page 5d.1, the **P1124** (6") Pipe Clamp is acceptable for a maximum horizontal F_{pASD} force = 360 lbf [C_T for transverse].

$$F_{pASD} (34.9 \text{ plf} \cdot 20 \text{ ft}) = 272.2 \text{ lbf} < 360 \text{ lbf. Therefore OK for the 6" pipe. } \checkmark$$

Select a Pipe Clamp for the 4" Pipes. Per OPM Page 5d.1, the **P1121** (4") Pipe Clamp is acceptable for a maximum horizontal F_{pASD} force = 360 lbf [C_T for transverse].

$$F_{pASD} (18.2 \text{ plf} \cdot 20 \text{ ft}) = 142.0 \text{ lbf} < 360 \text{ lbf. Therefore OK for the 4" pipes. } \checkmark$$

Step 7: Determine vertical hanger rod, stiffener and connection to channel per Sections 5 & 6.

Per Step 5 above, the transverse brace will be attached adjacent to the rod on one side of the trapeze. For both sides, try Detail 5a.6-1. Per OPM Page 5a.6: The connection is acceptable for a maximum vertical T_{Vert} or C_{Vert} force = 3,000 lbf when used with a 5/8" Threaded Rod.

$$T_{Vert} = 1,112.5 \text{ lbf} \quad \text{and} \quad C_{Vert} = 351.5 \text{ lbf} < 3,000 \text{ lbf. Therefore OK at brace. } \checkmark$$

Per OPM Page 6d.2 Note 1, the length of the threaded rod (4 ft) exceeds 30", thus Rod Stiffeners are required.

Per OPM Page 6d.3, the maximum acceptable compression force for a 5/8" diameter rod with stiffener and bolt spacing at 24" and maximum rod length not exceeding 9.6', $F_{pASD} = 859 \text{ lbf}$.

$$F_{pASD} (W_p (L_T)) = 556.1 \text{ lbf} < 859 \text{ lbf. Therefore OK at brace. } \checkmark$$

Therefore, a rod stiffener is required with a clip spacing (L) of 24" maximum.

Atkore
Unistrut

16100 S. Lathrop Ave
Harvey, IL 60426
Toll-Free: (800) 882-5543

www.unistrutseismic.com

Structural Engineer: Rami Elhassan
California SE No. 3930

Page:

8b.4

Trapeze Supported Component(s) Seismic Restraint Design Example

TRAPEZE SUPPORTED COMPONENT(S) SEISMIC RESTRAINT DESIGN EXAMPLE (CONTINUED...)

Step 8: Determine trapeze beam member per Sections 4.

Total load on a trapeze beam G_{Vert}

$$G_{Vert} := W_p(10 \text{ ft}) + E_{vASD}(W_p(10 \text{ ft})) = 834.2 \text{ lbf}$$

Trapeze beam to span 24", conservatively assuming that load is concentrated at center. Try P1001WT with slots sized for the 5/8" rod. From OPM Page 4b.2, the maximum allowable load for both strength and a span/180 deflection is,

$$G_{allow} := 0.5 \cdot (3,330 \cdot 1 - 3.78) \text{ lbf} = 1,661.2 \text{ lbf}$$

Therefore P1001WT beam is OK at brace. ✓

Note: For rectangular duct, if the duct is support by two channels (top and bottom) per pages 3d.1 & 3d.2, G_{Vert} may be divided by 2, reducing the load through each channel. Note that back-to-back channels as used in this example may not be used with attachment "Option 1" on pages 3d.1 and 3d.2.

Example Notes:

If the capacity is exceeded at Steps 4 through 8, the design should be modified such that braces are spaced closer and the demand force is reduced to meet ALL of the brace component capacities.

Step 9: Continue to design for longitudinal braces.

Continue to design the longitudinal braces, following steps similar to Steps 3 through 7.

Seismic force at each longitudinal brace:

Use a longitudinal brace spacing of $I_L := 30 \text{ ft}$: Jeffrey Y. Kikumoto

Two (2) - longitudinal braces will be used, one at each end of the trapeze beam member. Each longitudinal brace is assumed to resist 2/3 of the pipe seismic load based on actual eccentricity.

Thus $I_L := 30 \text{ ft} \cdot \frac{2}{3} = 20 \text{ ft}$ and $W_p(I_v) = 1,426 \text{ lbf}$
 $E_{vASD}(W_p(I_L)) = 556.1 \text{ lbf}$

Gravity and vertical seismic forces at the vertical hanger connection with a brace:

Two (2) - vertical hangers are spaced at 10'-0" on center, each vertical hanger is assumed to resist 2/3 of the pipe weight based on actual eccentricity. Therefore,

$$I_v := 10 \text{ ft} \cdot \frac{2}{3} = 6.67 \text{ ft} \quad \text{and} \quad W_p(I_v) = 475.6 \text{ lbf}$$

$$E_{vASD}(W_p(I_v)) = 80.8 \text{ lbf}$$

 <p style="font-size: small; margin-top: 10px;">16100 S. Lathrop Ave Harvey, IL 60426 Toll-Free: (800) 882-5543</p> <p style="font-size: x-small; text-align: center;">www.unistrutseismic.com</p>		Page:
	Structural Engineer: Rami Elhassan California SE No. 3930	8b.5

Trapeze Supported Component(s) Seismic Restraint Design Example

TRAPEZE SUPPORTED COMPONENT(S) SEISMIC RESTRAINT DESIGN EXAMPLE (CONTINUED...)

θ is the brace angle from horizontal at the vertical hanger. Choose a brace angle of 45°.

$$\theta := 45^\circ$$

Maximum tension in vertical hanger T_{Vert}

$$T_{Vert} := \frac{W_P(I_V)}{\text{Gravity Weight}} + \frac{E_{vASD}(W_P(I_V))}{\text{Vertical Seismic Force}} + \frac{F_{pASD}(W_P(I_L)) \cdot \tan(\theta)}{\text{Vertical Force from Horizontal Seismic Force Through Brace}} = 1,112.5 \text{ lbf}$$

Maximum compression in vertical hanger C_{Vert}

$$C_{Vert} := (-0.6) W_P(I_V) + E_{vASD}(W_P(I_V)) + F_{pASD}(W_P(I_L)) \cdot \tan(\theta) = 351.5 \text{ lbf}$$

For anchorage design where Ω_0 is required by governing code:

$$T_{Vert\Omega_0} := W_P(I_V) + E_{vASD}(W_P(I_V)) + \Omega_0 \cdot F_{pASD}(W_P(I_L)) \cdot \tan(\theta) = 1,668.6 \text{ lbf}$$

Determine attachment to structure per Section 7.

As stated above, the supporting structure is a 10" thick concrete slab.

Per OPM Page 7a.1: Two (2) 1/2" diameter expansion anchors with 3 1/4" embedments at 12" O.C. are acceptable for a maximum horizontal F_{pASD} force = 1,239 lbf.

$$F_{pASD}(W_P(I_L)) = 556.1 \text{ lbf} < 1,239 \text{ lbf. Therefore OK at brace. } \checkmark$$

Per OPM Page 1h.4, Table 3: A single (1) 5/8" diameter expansion anchor with a 4 1/4" embedment is acceptable for a maximum vertical $T_{Vert\Omega_0}$ force = 3,113 lbf.

$$T_{Vert\Omega_0} = 1,668.6 \text{ lbf} < 3,113 \text{ lbf. Therefore OK at the hanger connected to a hanger. } \checkmark$$

Determine brace member, fittings and connections per Sections 4 & 5.

Braces to be at $\theta := 45^\circ$ Try a P3810-050 for the brace fitting.

Per OPM Page 5c.1: A P3810-050 fitting is acceptable for a maximum horizontal F_{pASD} force = 985 lbf.

$$F_{pASD}(W_P(I_L)) = 556.1 \text{ lbf} < 985 \text{ lbf. Therefore OK at brace. } \checkmark$$

The pipe will be supported 4'-0" maximum from support structure. Provide lateral braces at $\theta = 45^\circ$.

Therefore, the maximum lateral brace length is approximately $\frac{4 \text{ ft}}{\cos(\theta)} = 5.657 \text{ ft}$, use 6'-0".

Try P1000 for the brace member. Per OPM Page 4a.1: A P1000 at a max length of 6'-0" is acceptable for a maximum horizontal F_{pASD} force = 1,470 lbf.

$$F_{pASD}(W_P(I_L)) = 556.1 \text{ lbf} < 1,470 \text{ lbf. Therefore OK at brace. } \checkmark$$

Atkore
Unistrut

16100 S. Lathrop Ave
Harvey, IL 60426
Toll-Free: (800) 882-5543

www.unistrutseismic.com

Rami Elhassan
Structural Engineer: Rami Elhassan
California SE No. 3930

Page:

8b.6

Trapeze Supported Component(s) Seismic Restraint Design Example

TRAPEZE SUPPORTED COMPONENT(S) SEISMIC RESTRAINT DESIGN EXAMPLE (CONTINUED...)

For the connection of the brace fitting to the channel beam, try Detail 5a.2-1 where the brace will be attached adjacent to the rod since a 5/8" rod is being used. Per OPM Page 5a.2: The connection is acceptable for a maximum horizontal F_{pASD} force = 2,375 lbf [use "Slip Resistance" F_p for transverse brace].

$$F_{pASD} (W_p (I_L)) = 556.1 \text{ lbf} < 2,375 \text{ lbf. Therefore OK at brace. } \checkmark$$

Determine Pipe Clamps per Section 5.

Select a Pipe Clamp for the 6" Pipe. Per OPM Page 5d.1, the **P1124** (6") Pipe Clamp is acceptable for a maximum horizontal F_{pASD} force = 525 lbf [C_L for longitudinal].

$$F_{pASD} (34.9 \text{ plf} \cdot 30 \text{ ft}) = 408.3 \text{ lbf} < 525 \text{ lbf. Therefore OK for the 6" pipes. } \checkmark$$

Select a Pipe Clamp for the 4" Pipes. Per OPM Page 5d.1, the **P1121** (4") Pipe Clamp is acceptable for a maximum horizontal F_{pASD} force = 730 lbf [C_L for longitudinal].

$$F_{pASD} (18.2 \text{ plf} \cdot 30 \text{ ft}) = 212.9 \text{ lbf} < 730 \text{ lbf. Therefore OK for the 4" pipes. } \checkmark$$

Determine vertical hanger rod, stiffener and connection to channel per Sections 5 & 6.

As stated above, longitudinal braces will be attached adjacent to the rods at both ends of the trapeze. For both other sides, try Detail 5a.6-1. Per OPM Page 5a.6: The connection is acceptable for a maximum vertical T_{Vert} or C_{Vert} force = 3,000 lbf when used with a 5/8" Threaded Rod.

$$T_{Vert} = 1,112.5 \text{ lbf} \text{ and } C_{Vert} = 351.5 \text{ lbf} < 3,000 \text{ lbf. Therefore OK at brace. } \checkmark$$

Per OPM Page 6d.2 Note 1, the length of the threaded rod (4 ft) exceeds 30", thus Rod Stiffeners are required.

Per OPM Page 6d.3, the maximum acceptable compression force for a 5/8" diameter rod with stiffener and bolt spacing at 24" and maximum rod length not exceeding 9.6', $F_{pASD} = 859 \text{ lbf}$.

$$F_{pASD} (W_p (I_L)) = 556.1 \text{ lbf} < 859 \text{ lbf. Therefore OK at brace. } \checkmark$$

Therefore, a rod stiffener is required with a clip spacing (L) of 24" maximum.

Example Notes:

If the capacity is exceeded at Step 9, the design should be modified such that braces are spaced closer and the demand force is reduced to meet ALL of the brace component capacities.

 <p style="text-align: center;">www.unistrutseismic.com</p>	16100 S. Lathrop Ave Harvey, IL 60426 Toll-Free: (800) 882-5543	 Structural Engineer: Rami Elhassan California SE No. 3930	Page: <h2 style="margin: 0;">8b.7</h2>
	DATE: 03/02/2020 BY: Jeffrey Y. Kikumoto OPM-0295-13		

Round Duct Seismic Restraint Design Example

ROUND DUCT SEISMIC RESTRAINT DESIGN EXAMPLE

Example Scenario:

A 36" diameter, 16 gage spiral galvanized steel round duct, in compliance with SMACNA standards, is being supported below the fourth floor of a seven story poured in-place concrete building. The floor and roof structure are comprised of a 10" thick concrete slab ($f'c = 4,000$ psi). The floor to floor height for each floor is 10'-0". The duct is vertically supported at 10'-0" on center maximum. The short period spectral acceleration, S_{DS} , per the provided construct documents is 1.2. The component importance factor is, $I_p = 1.5$.

Note: Reference Pages 3e.1 and 3e.2 for transverse and longitudinal bracing details.

Step 1: Determine F_p

Per ASCE 7-10 Table 13.6-1 (or Page 1i.5):

$$a_p := 2.5 \quad R_p := 6 \quad \text{and} \quad \Omega_o := 2.0$$

For ductwork, including in-line components, constructed of high- or limited-deformability materials with joints made by means other than welding or brazing.

$$\text{And} \quad S_{DS} := 1.2 \quad I_p := 1.5 \quad z := 30 \text{ ft} \quad h := 70 \text{ ft}$$

Per ASCE 7-10 Chapter 13, Eq 13.3-1 to 13.3-3 (or Page 1i.2):

$$F_p(W_p) := \frac{0.4 a_p \cdot S_{DS} \cdot \left(1 + 2 \cdot \frac{z}{h}\right) \cdot W_p}{\frac{R_p}{I_p}} \rightarrow 0.56 \cdot W_p$$

F_p is not required to be taken as greater than (Per Page 1i.2)

$$F_{pMax}(W_p) := 1.6 S_{DS} \cdot I_p \cdot W_p \rightarrow 2.88 \cdot W_p$$

and F_p shall not be taken as less than (Per Page 1i.2)

$$F_{pMin}(W_p) := 0.3 S_{DS} \cdot I_p \cdot W_p \rightarrow 0.54 \cdot W_p$$

$$\text{Governing} \quad F_{pLRFD}(W_p) := F_p(W_p) \rightarrow 0.56 \cdot W_p$$

$$\text{And} \quad F_{pASD}(W_p) := 0.7 F_{pLRFD}(W_p) \rightarrow 0.39 \cdot W_p$$

$$\text{Whereas, the vertical seismic force } E_v, \quad E_{vLRFD}(W_p) := 0.2 S_{DS} \cdot W_p \rightarrow 0.24 \cdot W_p$$

$$\text{And} \quad E_{vASD}(W_p) := 0.7 E_{vLRFD}(W_p) \rightarrow 0.17 \cdot W_p$$

Atkore
Unistrut

16100 S. Lathrop Ave
Harvey, IL 60426
Toll-Free: (800) 882-5543

www.unistrutseismic.com



Structural Engineer: Rami Elhassan
California SE No. 3930

Page:

8c.1

Round Duct Seismic Restraint Design Example

ROUND DUCT SEISMIC RESTRAINT DESIGN EXAMPLE (CONTINUED...)

Step 2: Determine Weight of Duct W_p

Per OPM Appendix Page A1.8, the self weight of a 36" diameter 16 gage spiral galvanized duct is,

$$W_p(I_{trib}) := 30.0plf \cdot I_{trib}$$

Step 3: Determine Seismic and Gravity Forces

Seismic force at each transverse brace:

Per OPM Page 1m.3, the maximum span for a 36" diameter round duct is 30', use 30'.

$$I_T := 30 \text{ ft}$$

Thus $W_p(I_T) = 900 \text{ lbf}$ and

$$F_{pASD}(W_p(I_T)) = 351 \text{ lbf}$$

Gravity and vertical seismic forces at the vertical hanger connection with a brace:

Split steel straps are used to clamp the duct as shown on OPM Pages 3e.1 and 3e.2.

Two (2) - vertical hangers connecting to the split steel straps are spaced at 10'-0" on center, each vertical hanger is assumed to resist 2/3 of the duct weight based on actual eccentricity. Therefore,

$$I_v := 10 \text{ ft} \cdot \frac{2}{3} = 6.67 \text{ ft} \quad \text{and} \quad W_p(I_v) = 200.1 \text{ lbf}$$

$$E_{vASD}(W_p(I_v)) = 34.1 \text{ lbf}$$

θ is the brace angle from horizontal at the vertical hanger. Choose a brace angle of 45°.

$$\theta := 45^\circ$$

Maximum tension in vertical hanger T_{Vert}

$$T_{Vert} := \underbrace{W_p(I_v)}_{\text{Gravity Weight}} + \underbrace{E_{vASD}(W_p(I_v))}_{\text{Vertical Seismic Force}} + \underbrace{F_{pASD}(W_p(I_T)) \cdot \tan(\theta)}_{\text{Vertical Force from Horizontal Seismic Force Through Brace}} = 585.2 \text{ lbf}$$

Maximum compression in vertical hanger C_{Vert}

$$C_{Vert} := (-0.6) W_p(I_v) + E_{vASD}(W_p(I_v)) + F_{pASD}(W_p(I_T)) \cdot \tan(\theta) = 265 \text{ lbf}$$

For anchorage design where Ω_0 is required by governing code:

$$T_{Vert\Omega_0} := W_p(I_v) + E_{vASD}(W_p(I_v)) + \Omega_0 \cdot F_{pASD}(W_p(I_T)) \cdot \tan(\theta) = 936.2 \text{ lbf}$$

Atkore
Unistrut

16100 S. Lathrop Ave
Harvey, IL 60426
Toll-Free: (800) 882-5543

www.unistrutseismic.com



Structural Engineer: Rami Elhassan
California SE No. 3930

Page:

8c.2

Round Duct Seismic Restraint Design Example

ROUND DUCT SEISMIC RESTRAINT DESIGN EXAMPLE (CONTINUED...)

Step 4: Determine attachment to structure per Section 7.

As stated above, the supporting structure is a 10" thick concrete slab.

Per OPM Page 7a.1: Single (1) 1/2" diameter expansion anchor with a 3 1/4" embedment is acceptable for a maximum horizontal F_{pASD} force = 612 lbf.

$$F_{pASD} (W_p (I_T)) = 351 \text{ lbf} < 612 \text{ lbf. Therefore OK at brace. } \checkmark$$

Per OPM Page 1h.4: Single (1) 1/2" diameter expansion anchor with a 3 1/4" embedment is acceptable for a maximum vertical $T_{Ver\Omega_0}$ force = 2,003 lbf.

$$T_{Ver\Omega_0} = 936.2 \text{ lbf} < 2,003 \text{ lbf. Therefore OK at hanger. } \checkmark$$

Step 5: Determine brace member, fittings and connections per Sections 4 & 5.

Braces to be at $\theta := 45^\circ$ Try **P3810-050** for the brace fitting.

Per OPM Page 5c.1: A **P3810-050** fitting is acceptable for a maximum horizontal F_{pASD} force = 985 lbf.

$$F_{pASD} (W_p (I_T)) = 351 \text{ lbf} < 985 \text{ lbf. Therefore OK at brace. } \checkmark$$

The duct will be supported 4'-0" maximum from support structure. Provide lateral braces at $\theta = 45^\circ$.

Therefore, the maximum lateral brace length is approximately $\frac{4 \text{ ft}}{\cos(\theta)} = 5.657 \text{ ft}$, use 6'-0".

Try **P1000** for the brace member. Per OPM Page 4a.1: A **P1000** at a max length of 6'-0" is acceptable for a maximum horizontal F_{pASD} force = 1,470 lbf.

$$F_{pASD} (W_p (I_T)) = 351 \text{ lbf} < 1,470 \text{ lbf. Therefore OK at brace. } \checkmark$$

Step 6: Determine vertical hanger rod, stiffener and connection to channel per Sections 5 & 6.

For connecting rod to steel duct strap, refer to Page 3e.1.

$$T_{Vert} = 585.2 \text{ lbf} \quad \text{and} \quad C_{Vert} = 265 \text{ lbf}$$

Per OPM Page 6d.2 Note 1, the length of the threaded rod (4 ft) exceeds 30", thus Rod Stiffeners are required.

Per OPM Page 6d.3, the maximum acceptable compression force for a 1/2" diameter rod with stiffener and bolt spacing at 21" and maximum rod length not exceeding 11.4', $F_{pASD} = 441 \text{ lbf}$.

$$F_{pASD} (W_p (I_T)) = 351 \text{ lbf} < 441 \text{ lbf. Therefore OK at brace. } \checkmark$$

Therefore, a rod stiffener is required with a clip spacing (L) of 21" maximum.

Example Notes:

If the capacity is exceeded at Steps 4 through 6, the design should be modified such that braces are spaced closer and the demand force is reduced to meet ALL of the brace component capacities.

 <p style="text-align: center;">www.unistrutseismic.com</p>	16100 S. Lathrop Ave Harvey, IL 60426 Toll-Free: (800) 882-5543	 Structural Engineer: Rami Elhassan California SE No. 3930	Page: <h2 style="margin: 0;">8c.3</h2>

Round Duct Seismic Restraint Design Example

ROUND DUCT SEISMIC RESTRAINT DESIGN EXAMPLE (CONTINUED...)

Step 7: Continue to design for longitudinal braces.

Continue to design the longitudinal braces, following steps similar to Steps 3 through 6.

Split steel straps are used to clamp the duct as shown on OPM Pages 3e.1 and 3e.2.

Two (2) - longitudinal braces will be used, one on each side of the split steel strap at the hanger rod. Each longitudinal brace is assumed to resist 2/3 of the duct seismic loads based on actual eccentricity.

Seismic force at each longitudinal brace:

Use a longitudinal brace spacing of $I_L := 60 \text{ ft}$

$$\text{Thus } I_L := 60 \text{ ft} \cdot \frac{2}{3} = 40 \text{ ft} \quad \text{and} \quad W_p(I_L) = 1,200 \text{ lbf}$$

$$F_{pASD}(W_p(I_L)) = 468 \text{ lbf}$$

Gravity and vertical seismic forces at the vertical hanger connection with a brace:

Two (2) - vertical hangers are spaced at 10'-0" on center, each vertical hanger is assumed to resist 2/3 of the pipe weight based on actual eccentricity. Therefore,

$$I_v := 10 \text{ ft} \cdot \frac{2}{3} = 6.67 \text{ ft} \quad \text{and} \quad W_p(I_v) = 200.1 \text{ lbf}$$

$$E_{vASD}(W_p(I_v)) = 34.1 \text{ lbf}$$

θ is the brace angle from horizontal at the vertical hanger. Choose a brace angle of 45°.

$$\theta_L := 45^\circ$$

Maximum tension in vertical hanger T_{Vert}

$$T_{LVert} := \underbrace{W_p(I_v)}_{\text{Gravity Weight}} + \underbrace{E_{vASD}(W_p(I_v))}_{\text{Vertical Seismic Force}} + \underbrace{F_{pASD}(W_p(I_L)) \cdot \tan(\theta)}_{\text{Vertical Force from Horizontal Seismic Force Through Brace}} = 702.2 \text{ lbf}$$

Maximum compression in vertical hanger C_{Vert}

$$C_{LVert} := (-0.6) W_p(I_v) + E_{vASD}(W_p(I_v)) + F_{pASD}(W_p(I_L)) \cdot \tan(\theta) = 382 \text{ lbf}$$

For anchorage design where Ω_0 is required by governing code:

$$T_{LVer\Delta_0} := W_p(I_v) + E_{vASD}(W_p(I_v)) + \Omega_0 \cdot F_{pASD}(W_p(I_L)) \cdot \tan(\theta) = 1,170.2 \text{ lbf}$$

Atkore
Unistrut

16100 S. Lathrop Ave
Harvey, IL 60426
Toll-Free: (800) 882-5543

www.unistrutseismic.com

Structural Engineer: Rami Elhassan
California SE No. 3930

Page:

8c.4

Round Duct Seismic Restraint Design Example

ROUND DUCT SEISMIC RESTRAINT DESIGN EXAMPLE (CONTINUED...)

Determine attachment to structure per Section 7.

As stated above, the supporting structure is a 10" thick concrete slab.

Per OPM Page 7a.1: Single (1) 1/2" diameter expansion anchor with a 3 1/4" embedment is acceptable for a maximum horizontal F_{pASD} force = 612 lbf.

$$F_{pASD} (W_P (I_L)) = 468 \text{ lbf} < 612 \text{ lbf. Therefore OK at brace. } \checkmark$$

Per OPM Page 1h.4: Single (1) 1/2" diameter expansion anchor with a 3 1/4" embedment is acceptable for a maximum vertical $T_{Ver\Omega_0}$ force = 2,003 lbf.

$$T_{LVer\Omega_0} = 1,170.2 \text{ lbf} < 2,003 \text{ lbf. Therefore OK at hanger. } \checkmark$$

Determine brace member, fittings and connections per Sections 4 & 5.

Braces to be at $\theta := 45^\circ$ Try P3810-050 for the brace fitting.

Per OPM Page 5c.1: A P3810-050 fitting is acceptable for a maximum horizontal F_{pASD} force = 985 lbf.

$$F_{pASD} (W_P (I_L)) = 468 \text{ lbf} < 985 \text{ lbf. Therefore OK at brace. } \checkmark$$

Try P1000 for the brace member. Per OPM Page 4a.1: A P1000 at a max length of 6'-0" is acceptable for a maximum horizontal F_{pASD} force = 1,470 lbf.

$$F_{pASD} (W_P (I_L)) = 468 \text{ lbf} < 1,470 \text{ lbf. Therefore OK at brace. } \checkmark$$

Determine vertical hanger rod, stiffener and connection to channel per Sections 5 & 6.

For connecting rod to steel duct strap, refer to Page 3e.1.

$$T_{Vert} = 702.2 \text{ lbf} \text{ and } C_{Vert} = 382 \text{ lbf} / 2020$$

Per OPM Page 6d.2 Note 1, the length of the threaded rod (4 ft) exceeds 30", thus Rod Stiffeners are required.

Per OPM Page 6d.3, the maximum acceptable compression force for a 1/2" diameter rod with stiffener and bolt spacing at 18" and maximum rod length not exceeding 9.8', $F_{pASD} = 601 \text{ lbf}$.

$$F_{pASD} (W_P (I_L)) = 468 \text{ lbf} < 601 \text{ lbf. Therefore OK at brace. } \checkmark$$

Therefore, a rod stiffener is required with a clip spacing (L) of 18" maximum.

Example Notes:

If the capacity is exceeded at Step 7, the design should be modified such that braces are spaced closer and the demand force is reduced to meet ALL of the brace component capacities.

 <p style="font-size: small; margin-top: 10px;">www.unistrutseismic.com</p>	16100 S. Lathrop Ave Harvey, IL 60426 Toll-Free: (800) 882-5543	 Structural Engineer: Rami Elhassan California SE No. 3930	Page: <h2 style="margin: 0;">8c.5</h2>
	www.unistrutseismic.com		

Appendices

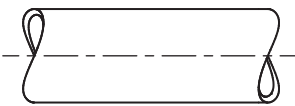
TYPE	PAGE
 <div style="display: inline-block; vertical-align: middle; margin-left: 20px;"> <p>System Weights - Reference</p> </div>	<p>A1.1 - A1.9</p>

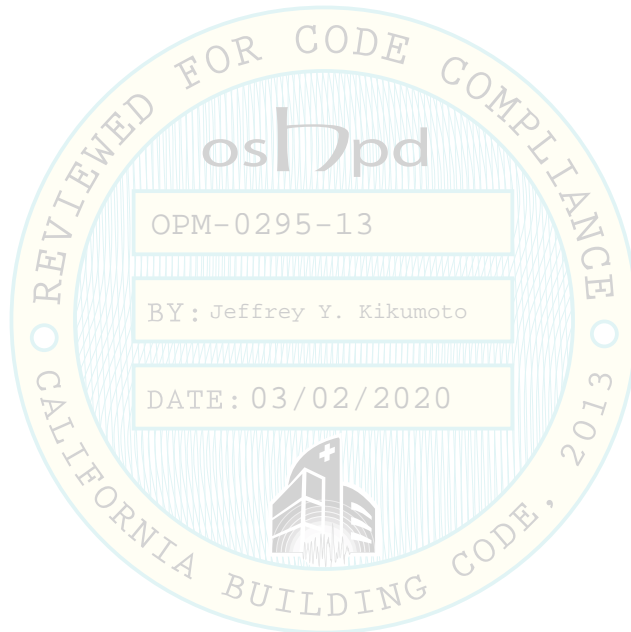

Appendix is not approved by OSHPD and is for reference only.

 <p style="margin-left: 100px;">16100 S. Lathrop Ave Harvey, IL 60426 Toll-Free: (800) 882-5543</p> <p style="text-align: center; margin-top: 10px;">www.unistrutseismic.com</p>		<p>Page:</p>
	<p>Structural Engineer: Rami Elhassan California SE No. 3930</p>	<p>A1.0</p>

System Self Weight

SCHEDULE 10 STEEL PIPE

Water Filled Pipe		
Pipe Diameter (in.)	Weight/Foot (lbs/ft)	
	Water Filled Pipe	Total ²
1	1.81	2.08
1 ¼	2.52	2.90
1 ½	3.04	3.50
2	4.22	4.85
2 ½	5.89	6.77
3	7.94	9.13
3 ½	9.78	11.25
4	11.78	13.55
5	17.30	19.90
6	23.03	26.48
8	40.08	46.09

¹Weights are based on NFPA 13 (2013 Edition), Table A.9.3.5.9
² Total includes a 15% fittings allowance

Water Filled Pipe + Insulation			
Pipe Diameter (in.)	Weight/Foot (lbs/ft)		
	Water Filled Pipe	Insulation	Total ²
1	1.81	0.7	2.89
1 ¼	2.52	0.8	3.82
1 ½	3.04	0.9	4.53
2	4.22	1.0	6.00
2 ½	5.89	1.2	8.15
3	7.94	1.3	10.63
3 ½	9.78	1.6	13.09
4	11.78	1.8	15.62
5	17.30	2.9	23.23
6	23.03	3.3	30.28
8	40.08	4.1	50.81

¹Weights are based on NFPA 13 (2013 Edition), Table A.9.3.5.9
² Total includes a 15% fittings allowance

SCHEDULE 40 STEEL PIPE

Water Filled Pipe			
Pipe Diameter (in.)	Weight/Foot (lbs/ft)		
	Pipe	Water	Total
1	1.7	0.4	2.1
1 ¼	2.3	0.6	2.9
1 ½	2.7	0.9	3.6
2	3.7	1.5	5.1
2 ½	5.8	2.1	7.9
3	7.6	3.2	10.8
3 ½	9.1	4.3	13.4
4	10.8	5.5	16.3
5	14.7	8.7	23.3
6	19.0	12.5	31.5
8	28.6	21.6	50.3

Water Filled Pipe + Insulation					
Pipe Diameter (in.)	Insulation Thickness (in.)	Weight/Foot (lbs/ft)			
		Pipe	Water	Insulation	Total
1	1	1.7	0.4	0.7	2.8
1 ¼	1	2.3	0.6	0.8	3.8
1 ½	1	2.7	0.9	0.9	4.6
2	1	3.7	1.5	1.0	6.2
2 ½	1	5.8	2.1	1.2	9.1
3	1	7.6	3.2	1.3	12.1
3 ½	1	9.1	4.3	1.5	15.0
4	1	10.8	5.5	1.8	18.2
5	1 ½	14.7	8.7	2.9	26.3
6	1 ½	19.0	12.5	3.3	34.9
8	1 ½	28.6	21.6	4.1	54.4



16100 S. Lathrop Ave
 Harvey, IL 60426
 Toll-Free: (800) 882-5543

www.unistrutseismic.com

Structural Engineer: Rami Elhassan
 California SE No. 3930

Page:

A1.1

System Self Weight

SCHEDULE 80 STEEL PIPE

Pipe Diameter (in.)	Insulation Thickness (in.)	Weight/Foot (lbs/ft)			
		Pipe	Water	Insulation	Total
1	1	2.2	0.3	0.7	3.2
1 ¼	1	3.0	0.6	0.8	4.4
1 ½	1	3.6	0.8	0.9	5.4
2	1	5.0	1.3	1.0	7.4
2 ½	1	7.7	1.8	1.2	10.8
3	1	10.3	2.9	1.3	14.5
3 ½	1	12.5	3.8	1.5	17.9
4	1	15.0	5.0	1.8	21.8
5	1 ½	20.8	7.9	2.9	31.7
6	1 ½	28.6	11.3	3.3	43.3
8	1 ½	43.5	19.8	4.1	67.4
10	1 ½	64.6	31.1	5.2	100.9
12	1 ½	88.8	44.0	6.0	138.9

NO-HUB CAST IRON PIPE

TYPICAL USES: WASTE, VENT, STORM DRAIN

Pipe Diameter (in.)	Weight/Foot (lbs/ft)		
	Pipe	Water	Total
1 ½	3.3	0.8	4.1
2	4.1	1.3	5.4
3	6.0	3.0	9.0
4	8.9	5.3	14.2
5	9.0	8.3	17.3
6	10.7	12.0	22.7
8	17.5	21.4	38.9
10	28.0	34.0	62.0
12	33.3	48.4	81.7

AWWA DUCTILE IRON PIPE

VALID FOR PRESSURE CLASSES 50 THRU 200 OR THICKNESS CLASSES 50 THRU 56

Pipe Diameter (in.)	Weight/Foot (lbs/ft)		
	Pipe	Water	Total
3	13.8	3.4	17.2
4	17.5	5.4	22.9
6	27.0	12.4	39.4
8	37.6	22.6	60.2
10	48.6	35.1	83.6
12	60.5	50.7	111.3



16100 S. Lathrop Ave
Harvey, IL 60426
Toll-Free: (800) 882-5543

www.unistrutseismic.com

Structural Engineer: Rami Elhassan
California SE No. 3930

Page:

A1.2

System Self Weight

COPPER TYPE K

Pipe Diameter (in.)	Insulation Thickness (in.)	Weight/Foot (lbs/ft)			
		Pipe	Water	Insulation	Total
1/4	1	0.145	0.032	0.2	0.377
3/8	1	0.269	0.055	0.3	0.624
1/2	1	0.344	0.094	0.4	0.838
5/8	1	0.418	0.144	0.5	1.062
3/4	1	0.641	0.188	0.6	1.429
1	1	0.839	0.336	0.7	1.88
1 1/4	1	1.040	0.526	0.8	2.37
1 1/2	1	1.36	0.74	0.9	3.00
2	1	2.06	1.30	1.0	4.36
2 1/2	1	2.93	2.01	1.2	6.14
3	1	4.00	2.87	1.3	8.17
3 1/2	1	5.12	3.89	1.5	10.51
4	1	6.51	5.05	1.8	13.36
5	1 1/2	9.67	7.84	2.9	20.41
6	1 1/2	13.9	11.2	3.3	28.4
8	1 1/2	25.9	19.5	4.1	49.5
10	1 1/2	40.3	30.3	5.2	75.8
12	1 1/2	57.8	43.5	6.0	107.3

COPPER TYPE L

Pipe Diameter (in.)	Insulation Thickness (in.)	Weight/Foot (lbs/ft)			
		Tube	Water	Insulation	Total
1/4	1	0.126	0.034	0.2	0.360
3/8	1	0.198	0.063	0.3	0.561
1/2	1	0.285	0.101	0.4	0.786
5/8	1	0.362	0.151	0.5	1.013
3/4	1	0.455	0.209	0.6	1.264
1	1	0.655	0.357	0.7	1.71
1 1/4	1	0.884	0.543	0.8	2.23
1 1/2	1	1.14	0.77	0.9	2.81
2	1	1.75	1.34	1.0	4.09
2 1/2	1	2.48	2.06	1.2	5.74
3	1	3.33	2.95	1.3	7.58
3 1/2	1	4.29	3.98	1.5	9.77
4	1	5.38	5.18	1.8	12.36
5	1 1/2	7.61	8.07	2.9	18.58
6	1 1/2	10.2	11.6	3.3	25.1
8	1 1/2	19.3	20.3	4.1	43.7
10	1 1/2	30.1	31.5	5.2	66.8
12	1 1/2	40.4	45.4	6.0	91.8

COPPER TYPE M

Pipe Diameter (in.)	Insulation Thickness (in.)	Weight/Foot (lbs/ft)			
		Tube	Water	Insulation	Total
3/8	1	0.145	0.069	0.3	0.514
1/2	1	0.204	0.110	0.4	0.714
3/4	1	0.328	0.223	0.6	1.151
1	1	0.465	0.378	0.7	1.54
1 1/4	1	0.682	0.566	0.8	2.05
1 1/2	1	0.94	0.79	0.9	2.63
2	1	1.46	1.37	1.0	3.83
2 1/2	1	2.03	2.11	1.2	5.34
3	1	2.68	3.02	1.3	7.00
3 1/2	1	3.58	4.06	1.5	9.14
4	1	4.66	5.26	1.8	11.72
5	1 1/2	6.7	8.18	2.9	17.74
6	1 1/2	8.9	11.7	3.3	24.0
8	1 1/2	16.5	20.6	4.1	41.2
10	1 1/2	25.6	32.0	5.2	62.8
12	1 1/2	36.7	45.8	6.0	88.5



16100 S. Lathrop Ave
Harvey, IL 60426
Toll-Free: (800) 882-5543

www.unistrutseismic.com

Structural Engineer: Rami Elhassan
California SE No. 3930

Page:

A1.3

System Self Weight

ELECTRICAL CONDUIT WEIGHTS

Conduit Diameter (in.)	Weight/Foot (lbs/ft)					
	Electrical Metallic Tubing (EMT)		Intermediate Metal Conduit (IMC)		Rigid Metal Conduit (RMC)	
	Conduit	Total ¹	Conduit	Total ¹	Conduit	Total ¹
1/2	0.30	0.52	0.62	0.84	0.82	1.04
3/4	0.46	0.87	0.84	1.25	1.09	1.50
1	0.67	1.33	1.19	1.85	1.61	2.27
1 1/4	1.01	2.18	1.58	2.75	2.18	3.50
1 1/2	1.16	2.76	1.94	3.54	2.63	4.40
2	1.48	4.10	2.56	5.18	3.50	7.02
2 1/2	2.16	5.90	4.41	8.15	5.59	9.97
3	2.63	8.39	5.43	11.69	7.27	14.15
3 1/2	3.49	11.22	6.29	14.02	8.80	17.10
4	3.93	13.87	7.00	16.99	10.30	20.91
5	-	-	-	-	14.00	29.99
6	-	-	-	-	18.40	42.61

¹ Total is the weight of the conduit plus the weight of the heaviest conductor combination (from the National Electrical Code Handbook).

CABLE TRAY WEIGHTS (WITH CABLE FILL)

NEMA (VE-1) LOADINGS¹

Tray / Load Designation	Class A	Class B	Class C
lbs/ft	50	75	100

POWER CABLES (MAX WEIGHTS/LOADS)^{1,2}

Tray Dimensions	6" Wide	9" Wide	12" Wide	18" Wide	24" Wide	30" Wide	36" Wide
Cable Fill Weight (lbs/ft)	25	35	45	70	90	115	140

DATA/COMMUNICATION CABLES (MAX WEIGHTS/LOADS)^{1,3,4}

Tray Depth (in.)	Tray Width (in.)						
	6" Wide	9" Wide	12" Wide	18" Wide	24" Wide	30" Wide	36" Wide
2" Depth	5	8	10	15	20	25	30
3" Depth	8	12	15	23	30	37	45
4" Depth	10	15	20	30	40	49	59
5" Depth	13	19	25	37	49	62	74
6" Depth	15	23	30	45	59	74	89

Notes:

- 1) All Cables Weights/Loads are in lbs/ft unless otherwise noted.
- 2) Larger diameter cables used in weight estimation, assuming cables weigh less than 3.8 lbs per inch width of cable tray and installed in a single layer.
- 3) Max 50% fill ratio used in calculations for Data/Communication Cables.
- 4) CAT6/CAT6E cables, O.D. = 0.25" nominal, weight = 0.040 lbs/ft.



16100 S. Lathrop Ave
Harvey, IL 60426
Toll-Free: (800) 882-5543

www.unistrutseismic.com

Structural Engineer: Rami Elhassan
California SE No. 3930

Page:

A1.4

System Self Weight

GALVANIZED RECTANGULAR DUCT

24 GAGE: SIZES 3" X 3" TO 28" X 28"

		Weight/Foot (lbs/ft)																
		Height (in.)																
		3	4	5	6	7	8	9	10	12	14	16	18	20	22	24	26	28
Width (in.)	3	1.3	1.5	1.7	2.0	2.2	2.4	2.6	2.8	3.3	3.7	4.1	4.6	5.0	5.4	5.9	6.3	6.7
	4		1.7	2.0	2.2	2.4	2.6	2.8	3.0	3.5	3.9	4.4	4.8	5.2	5.7	6.1	6.5	7.0
	5			2.2	2.4	2.6	2.8	3.0	3.3	3.7	4.1	4.6	5.0	5.4	5.9	6.3	6.7	7.2
	6				2.6	2.8	3.0	3.3	3.5	3.9	4.4	4.8	5.2	5.7	6.1	6.5	7.0	7.4
	7					3.0	3.3	3.5	3.7	4.1	4.6	5.0	5.4	5.9	6.3	6.7	7.2	7.6
	8						3.5	3.7	3.9	4.4	4.8	5.2	5.7	6.1	6.5	7.0	7.4	7.8
	9							3.9	4.1	4.6	5.0	5.4	5.9	6.3	6.7	7.2	7.6	8.1
	10								4.4	4.8	5.2	5.7	6.1	6.5	7.0	7.4	7.8	8.3
	12									5.2	5.7	6.1	6.5	7.0	7.4	7.8	8.3	8.7
	14										6.1	6.5	7.0	7.4	7.8	8.3	8.7	9.1
	16											7.0	7.4	7.8	8.3	8.7	9.1	9.6
	18												7.8	8.3	8.7	9.1	9.6	10.0
	20													8.7	9.1	9.6	10.0	10.5
	22														9.6	10.0	10.5	10.9
24															10.5	10.9	11.3	
26																11.3	11.8	
28																	12.2	

Notes: 1) Weights include allowance for laps and seams

Gage Conversion Chart - Weight/Foot (lbs/ft)								
Gage		To						
		28	26	24	22	20	18	16
From	28	1.00	1.16	1.48	1.80	2.12	2.76	3.40
	26	0.86	1.00	1.28	1.55	1.83	2.38	2.93
	24	0.68	0.78	1.00	1.22	1.43	1.87	2.30
	22	0.56	0.64	0.82	1.00	1.18	1.53	1.89
	20	0.47	0.55	0.70	0.85	1.00	1.30	1.60
	18	0.36	0.42	0.54	0.65	0.77	1.00	1.23
	16	0.29	0.34	0.44	0.53	0.62	0.81	1.00

Notes: 1) Weight conversions can be used for any galvanized sheet duct.



16100 S. Lathrop Ave
Harvey, IL 60426
Toll-Free: (800) 882-5543

www.unistrutseismic.com

Structural Engineer: Rami Elhassan
California SE No. 3930

Page:

A1.5

System Self Weight

GALVANIZED RECTANGULAR DUCT

22 GAGE: SIZES 30" x 3" TO 40" x 40"

20 GAGE: SIZES 42" x 3" TO 58" x 58"

		Weight/Foot (lbs/ft)					
		Height (in.)					
		30	32	34	36	38	40
Width (in.)	3	8.6	9.1	9.7	10.2	10.7	11.2
	4	8.9	9.4	9.9	10.5	11.0	11.5
	5	9.1	9.7	10.2	10.7	11.2	11.8
	6	9.4	9.9	10.5	11.0	11.5	12.0
	7	9.7	10.2	10.7	11.2	11.8	12.3
	8	9.9	10.5	11.0	11.5	12.0	12.5
	9	10.2	10.7	11.2	11.8	12.3	12.8
	10	10.5	11.0	11.5	12.0	12.5	13.1
	12	11.0	11.5	12.0	12.5	13.1	13.6
	14	11.5	12.0	12.5	13.1	13.6	14.1
	16	12.0	12.5	13.1	13.6	14.1	14.6
	18	12.5	13.1	13.6	14.1	14.6	15.2
	20	13.1	13.6	14.1	14.6	15.2	15.7
	22	13.6	14.1	14.6	15.2	15.7	16.2
	24	14.1	14.6	15.2	15.7	16.2	16.7
	26	14.6	15.2	15.7	16.2	16.7	17.2
28	15.2	15.7	16.2	16.7	17.2	17.8	
30	15.7	16.2	16.7	17.2	17.8	18.3	
32		16.7	17.2	17.8	18.3	18.8	
34			17.8	18.3	18.8	19.3	
36				18.8	19.3	19.9	
38					19.9	20.4	
40						20.9	

Notes:

1) Weights include allowance for laps and seams

		Weight/Foot (lbs/ft)									
		Height (in.)									
		42	44	46	48	50	52	54	56	58	
Width (in.)	3	13.4	13.9	14.5	15.1	15.7	16.3	16.9	17.5	18.1	
	4	13.6	14.2	14.8	15.4	16.0	16.6	17.2	17.8	18.4	
	5	13.9	14.5	15.1	15.7	16.3	16.9	17.5	18.1	18.7	
	6	14.2	14.8	15.4	16.0	16.6	17.2	17.8	18.4	19.0	
	7	14.5	15.1	15.7	16.3	16.9	17.5	18.1	18.7	19.3	
	8	14.8	15.4	16.0	16.6	17.2	17.8	18.4	19.0	19.6	
	9	15.1	15.7	16.3	16.9	17.5	18.1	18.7	19.3	19.9	
	10	15.4	16.0	16.6	17.2	17.8	18.4	19.0	19.6	20.2	
	12	16.0	16.6	17.2	17.8	18.4	19.0	19.6	20.2	20.8	
	14	16.6	17.2	17.8	18.4	19.0	19.6	20.2	20.8	21.4	
	16	17.2	17.8	18.4	19.0	19.6	20.2	20.8	21.4	22.0	
	18	17.8	18.4	19.0	19.6	20.2	20.8	21.4	22.0	22.5	
	20	18.4	19.0	19.6	20.2	20.8	21.4	22.0	22.5	23.1	
	22	19.0	19.6	20.2	20.8	21.4	22.0	22.5	23.1	23.7	
	24	19.6	20.2	20.8	21.4	22.0	22.5	23.1	23.7	24.3	
	26	20.2	20.8	21.4	22.0	22.5	23.1	23.7	24.3	24.9	
	28	20.8	21.4	22.0	22.5	23.1	23.7	24.3	24.9	25.5	
	30	21.4	22.0	22.5	23.1	23.7	24.3	24.9	25.5	26.1	
	32	22.0	22.5	23.1	23.7	24.3	24.9	25.5	26.1	26.7	
	34	22.5	23.1	23.7	24.3	24.9	25.5	26.1	26.7	27.3	
36	23.1	23.7	24.3	24.9	25.5	26.1	26.7	27.3	27.9		
38	23.7	24.3	24.9	25.5	26.1	26.7	27.3	27.9	28.5		
40	24.3	24.9	25.5	26.1	26.7	27.3	27.9	28.5	29.1		
42	24.9	25.5	26.1	26.7	27.3	27.9	28.5	29.1	29.7		
44		26.1	26.7	27.3	27.9	28.5	29.1	29.7	30.3		
46			27.3	27.9	28.5	29.1	29.7	30.3	30.9		
48				28.5	29.1	29.7	30.3	30.9	31.5		
50					29.7	30.3	30.9	31.5	32.0		
52						30.9	31.5	32.0	32.6		
54							32.0	32.6	33.2		
56								33.2	33.8		
58									34.4		

Notes: 1) Weights include allowance for laps and seams



16100 S. Lathrop Ave
Harvey, IL 60426
Toll-Free: (800) 882-5543

www.unistrutseismic.com

Structural Engineer: Rami Elhassan
California SE No. 3930

Page:

A1.6

System Self Weight

GALVANIZED RECTANGULAR DUCT

18 GAGE: SIZES 60" x 6" TO 98" x 98"

		Weight/Foot (lbs/ft)																			
		Height (in.)																			
		60	62	64	66	68	70	72	74	76	78	80	82	84	86	88	90	92	94	96	98
Width (in.)	6	25.5	26.3	27.0	27.8	28.6	29.4	30.1	30.9	31.7	32.4	33.2	34.0	34.8	35.5	36.3	37.1	37.9	38.6	39.4	40.2
	8	26.3	27.0	27.8	28.6	29.4	30.1	30.9	31.7	32.4	33.2	34.0	34.8	35.5	36.3	37.1	37.9	38.6	39.4	40.2	40.9
	10	27.0	27.8	28.6	29.4	30.1	30.9	31.7	32.4	33.2	34.0	34.8	35.5	36.3	37.1	37.9	38.6	39.4	40.2	40.9	41.7
	12	27.8	28.6	29.4	30.1	30.9	31.7	32.4	33.2	34.0	34.8	35.5	36.3	37.1	37.9	38.6	39.4	40.2	40.9	41.7	42.5
	14	28.6	29.4	30.1	30.9	31.7	32.4	33.2	34.0	34.8	35.5	36.3	37.1	37.9	38.6	39.4	40.2	40.9	41.7	42.5	43.3
	16	29.4	30.1	30.9	31.7	32.4	33.2	34.0	34.8	35.5	36.3	37.1	37.9	38.6	39.4	40.2	40.9	41.7	42.5	43.3	44.0
	18	30.1	30.9	31.7	32.4	33.2	34.0	34.8	35.5	36.3	37.1	37.9	38.6	39.4	40.2	40.9	41.7	42.5	43.3	44.0	44.8
	20	30.9	31.7	32.4	33.2	34.0	34.8	35.5	36.3	37.1	37.9	38.6	39.4	40.2	40.9	41.7	42.5	43.3	44.0	44.8	45.6
	22	31.7	32.4	33.2	34.0	34.8	35.5	36.3	37.1	37.9	38.6	39.4	40.2	40.9	41.7	42.5	43.3	44.0	44.8	45.6	46.4
	24	32.4	33.2	34.0	34.8	35.5	36.3	37.1	37.9	38.6	39.4	40.2	40.9	41.7	42.5	43.3	44.0	44.8	45.6	46.4	47.1
	26	33.2	34.0	34.8	35.5	36.3	37.1	37.9	38.6	39.4	40.2	40.9	41.7	42.5	43.3	44.0	44.8	45.6	46.4	47.1	47.9
	28	34.0	34.8	35.5	36.3	37.1	37.9	38.6	39.4	40.2	40.9	41.7	42.5	43.3	44.0	44.8	45.6	46.4	47.1	47.9	48.7
	30	34.8	35.5	36.3	37.1	37.9	38.6	39.4	40.2	40.9	41.7	42.5	43.3	44.0	44.8	45.6	46.4	47.1	47.9	48.7	49.4
	32	35.5	36.3	37.1	37.9	38.6	39.4	40.2	40.9	41.7	42.5	43.3	44.0	44.8	45.6	46.4	47.1	47.9	48.7	49.4	50.2
	34	36.3	37.1	37.9	38.6	39.4	40.2	40.9	41.7	42.5	43.3	44.0	44.8	45.6	46.4	47.1	47.9	48.7	49.4	50.2	51.0
	36	37.1	37.9	38.6	39.4	40.2	40.9	41.7	42.5	43.3	44.0	44.8	45.6	46.4	47.1	47.9	48.7	49.4	50.2	51.0	51.8
	38	37.9	38.6	39.4	40.2	40.9	41.7	42.5	43.3	44.0	44.8	45.6	46.4	47.1	47.9	48.7	49.4	50.2	51.0	51.8	52.5
	40	38.6	39.4	40.2	40.9	41.7	42.5	43.3	44.0	44.8	45.6	46.4	47.1	47.9	48.7	49.4	50.2	51.0	51.8	52.5	53.3
	42	39.4	40.2	40.9	41.7	42.5	43.3	44.0	44.8	45.6	46.4	47.1	47.9	48.7	49.4	50.2	51.0	51.8	52.5	53.3	54.1
	44	40.2	40.9	41.7	42.5	43.3	44.0	44.8	45.6	46.4	47.1	47.9	48.7	49.4	50.2	51.0	51.8	52.5	53.3	54.1	54.9
	46	40.9	41.7	42.5	43.3	44.0	44.8	45.6	46.4	47.1	47.9	48.7	49.4	50.2	51.0	51.8	52.5	53.3	54.1	54.9	55.6
	48	41.7	42.5	43.3	44.0	44.8	45.6	46.4	47.1	47.9	48.7	49.4	50.2	51.0	51.8	52.5	53.3	54.1	54.9	55.6	56.4
	50	42.5	43.3	44.0	44.8	45.6	46.4	47.1	47.9	48.7	49.4	50.2	51.0	51.8	52.5	53.3	54.1	54.9	55.6	56.4	57.2
	52	43.3	44.0	44.8	45.6	46.4	47.1	47.9	48.7	49.4	50.2	51.0	51.8	52.5	53.3	54.1	54.9	55.6	56.4	57.2	57.9
	54	44.0	44.8	45.6	46.4	47.1	47.9	48.7	49.4	50.2	51.0	51.8	52.5	53.3	54.1	54.9	55.6	56.4	57.2	57.9	58.7
	56	44.8	45.6	46.4	47.1	47.9	48.7	49.4	50.2	51.0	51.8	52.5	53.3	54.1	54.9	55.6	56.4	57.2	57.9	58.7	59.5
	58	45.6	46.4	47.1	47.9	48.7	49.4	50.2	51.0	51.8	52.5	53.3	54.1	54.9	55.6	56.4	57.2	57.9	58.7	59.5	60.3
	60	46.4	47.1	47.9	48.7	49.4	50.2	51.0	51.8	52.5	53.3	54.1	54.9	55.6	56.4	57.2	57.9	58.7	59.5	60.3	61.0
62		47.9	48.7	49.4	50.2	51.0	51.8	52.5	53.3	54.1	54.9	55.6	56.4	57.2	57.9	58.7	59.5	60.3	61.0	61.8	
64			49.4	50.2	51.0	51.8	52.5	53.3	54.1	54.9	55.6	56.4	57.2	57.9	58.7	59.5	60.3	61.0	61.8	62.6	
66				51.0	51.8	52.5	53.3	54.1	54.9	55.6	56.4	57.2	57.9	58.7	59.5	60.3	61.0	61.8	62.6	63.4	
68					52.5	53.3	54.1	54.9	55.6	56.4	57.2	57.9	58.7	59.5	60.3	61.0	61.8	62.6	63.4	64.1	
70						54.1	54.9	55.6	56.4	57.2	57.9	58.7	59.5	60.3	61.0	61.8	62.6	63.4	64.1	64.9	
72							55.6	56.4	57.2	57.9	58.7	59.5	60.3	61.0	61.8	62.6	63.4	64.1	64.9	65.7	
74								57.2	57.9	58.7	59.5	60.3	61.0	61.8	62.6	63.4	64.1	64.9	65.7	66.4	
76									58.7	59.5	60.3	61.0	61.8	62.6	63.4	64.1	64.9	65.7	66.4	67.2	
78										60.3	61.0	61.8	62.6	63.4	64.1	64.9	65.7	66.4	67.2	68.0	
80											61.8	62.6	63.4	64.1	64.9	65.7	66.4	67.2	68.0	68.8	
82												63.4	64.1	64.9	65.7	66.4	67.2	68.0	68.8	69.5	
84													64.9	65.7	66.4	67.2	68.0	68.8	69.5	70.3	
86														66.4	67.2	68.0	68.8	69.5	70.3	71.1	
88															68.0	68.8	69.5	70.3	71.1	71.8	
90																69.5	70.3	71.1	71.8	72.6	
92																	71.1	71.8	72.6	73.4	
94																		72.6	73.4	74.2	
96																			74.2	74.9	
98																				75.7	

Notes: 1) Weights include allowance for laps and seams

 <p>16100 S. Lathrop Ave Harvey, IL 60426 Toll-Free: (800) 882-5543</p> <p style="text-align: center;">www.unistrutseismic.com</p>	 Structural Engineer: Rami Elhassan California SE No. 3930	Page: <h2 style="margin: 0;">A1.7</h2>
	<p>02/27/2020 146 of 151</p>	

System Self Weight

GALVANIZED ROUND DUCT

30 TO 24 GAGE: SIZES 3" x 84"

Weight/Foot (lbs/ft)								
Diameter (in.)	30 Gage Seam Gage		28 Gage Seam Gage		26 Gage Seam Gage		24 Gage Seam Gage	
	Spiral	Long.	Spiral	Long.	Spiral	Long.	Spiral	Long.
3	0.6	0.60	0.7	0.71	0.9	0.82	1.0	1.05
4	0.8	0.77	0.9	0.92	1.2	1.06	1.3	1.36
5	0.9	0.94	1.1	1.12	1.4	1.30	1.6	1.66
6	1.1	1.11	1.4	1.32	1.7	1.54	2.0	1.96
7	1.3	1.28	1.6	1.53	1.9	1.77	2.4	2.26
8	1.5	1.46	1.9	1.73	2.1	2.01	2.6	2.57
9	1.6	1.63	2.0	1.94	2.3	2.25	3.0	2.87
10	1.9	1.80	2.2	2.14	2.5	2.48	3.3	3.17
11	2.0	1.97	2.4	2.35	2.8	2.72	3.6	3.48
12	2.2	2.14	2.6	2.55	3.0	2.96	3.8	3.78
14		2.49	3.0	2.96	3.5	3.43	4.4	4.38
16		2.83	3.4	3.37	4.0	3.91	5.1	4.99
18		3.18	3.8	3.78	4.4	4.38	5.7	5.59
20			4.2	4.19	5.0	4.86	6.4	6.20
22			4.7	4.60	5.4	5.33	7.0	6.80
24			5.2	5.01	6.0	5.80	7.8	7.41
26					6.6	6.28	8.5	8.02
28					7.0	6.75	8.9	8.62
30					7.1	7.23	9.3	9.23
32						7.70	10.1	9.83
34						8.18		10.44
36						8.65	11.5	11.05
40						9.60	12.8	12.26
44						10.55	14.4	13.47
48						11.50	15.4	14.68
50							16.0	15.28
54								16.50
56								17.10
60								18.31
72								21.95
84								25.58

Notes: 1) Weights include allowance for laps and seams



16100 S. Lathrop Ave
Harvey, IL 60426
Toll-Free: (800) 882-5543

www.unistrutseismic.com

Structural Engineer: Rami Elhassan
California SE No. 3930

Page:

A1.8

System Self Weight

GALVANIZED ROUND DUCT

22 TO 16 GAGE: SIZES 3" x 84"

Diameter (in.)	Weight/Foot (lbs/ft)							
	22 Gage Seam Gage		20 Gage Seam Gage		18 Gage Seam Gage		16 Gage Seam Gage	
	Spiral	Long.	Spiral	Long.	Spiral	Long.	Spiral	Long.
3	1.2	1.28	1.3	1.51	2.0	1.97		2.42
4	1.5	1.65	1.8	1.94	2.6	2.53		3.12
5	2.0	2.02	2.3	2.38	3.2	3.10		3.81
6	2.4	2.39	2.6	2.81	3.7	3.66	5.0	4.51
7	2.8	2.75	3.3	3.24	4.3	4.23	5.8	5.20
8	3.2	3.12	3.7	3.68	4.8	4.79	6.7	5.90
9	3.5	3.49	4.0	4.11	5.3	5.36	7.5	6.60
10	4.0	3.86	4.7	4.54	6.0	5.92	8.3	7.29
11	4.4	4.23	5.1	4.98	6.7	6.49		7.99
12	4.7	4.60	5.2	5.41	7.2	7.05	10.0	8.68
14	5.4	5.33	6.4	6.28	8.3	8.19	11.7	10.08
16	6.2	6.07	7.3	7.15	9.4	9.32	13.4	11.47
18	6.9	6.80	8.1	8.01	10.5	10.45	15.0	12.86
20	7.8	7.54	9.0	8.88	11.7	11.58	16.7	14.25
22	8.4	8.28	9.9	9.75	12.9	12.71	18.4	15.64
24	9.5	9.01	11.0	10.62	14.4	13.84	20.0	17.04
26	10.3	9.75	12.2	11.48	15.8	14.97	21.7	18.43
28	11.0	10.49	12.9	12.35	16.5	16.10	23.4	19.82
30	11.8	11.22	13.6	13.22	17.2	17.23	25.0	21.21
32	12.6	11.96	14.6	14.09	18.9	18.36	26.7	22.60
34		12.70		14.95		19.49		24.00
36	14.2	13.43	16.6	15.82	21.5	20.62	30.0	25.39
40	15.5	14.91	18.5	17.56	23.8	22.88	33.4	28.17
44	17.4	16.38	20.5	19.29	26.7	25.15	36.7	30.96
48	18.7	17.85	22.2	21.03	29.2	27.41	40.1	33.74
50	19.5	18.59	23.3	21.89	30.0	28.54	41.7	35.13
54		20.06		23.63		30.80	45.1	37.91
56		20.79		24.50		31.93	46.7	39.31
60		22.27		26.23		34.19	50.1	42.09
72		26.69		31.44		40.98		50.44
84		31.11		36.64		47.76		58.79

Notes: 1) Weights include allowance for laps and seams



16100 S. Lathrop Ave
Harvey, IL 60426
Toll-Free: (800) 882-5543

www.unistrutseismic.com

Structural Engineer: Rami Elhassan
California SE No. 3930

Page:

A1.9



Atkore

16100 South Lathrop Avenue
Harvey, IL 60426

TOLL FREE / 800-882-5543

FAX / 708-339-7814

www.atkore.com