



OFFICE OF STATEWIDE HEALTH PLANNING AND DEVELOPMENT
FACILITIES DEVELOPMENT DIVISION

APPLICATION FOR OSHPD PREAPPROVAL OF
MANUFACTURER'S CERTIFICATION (OPM)

OFFICE USE ONLY

APPLICATION #: OPM-0321

OSHPD Preapproval of Manufacturer's Certification (OPM)

Type: [] New [X] Renewal/Update

Manufacturer Information

Manufacturer: Shimadzu Medical Systems

Manufacturer's Technical Representative: Jim Mekker

Mailing Address: 20101 S. Vermont Ave., Torrance, CA 60502

Telephone: (216) 288-0709 Email: mekker@shimadzu-usa.com

Product Information

Product Name: D150BC-40S GENERATOR CABINET

Product Type: Generator

Product Model Number: D150BC-40S

General Description: Subcomponent of Sonialvision G4 System

Applicant Information

Applicant Company Name: EASE LLC.

Contact Person: Tiffany Tonn

Mailing Address: 1515 FAIRVIEW AVE, STE 205, MISSOULA, MT 59801

Telephone: (406) 541-3273 Email: tiffany@easeco.com

Title:

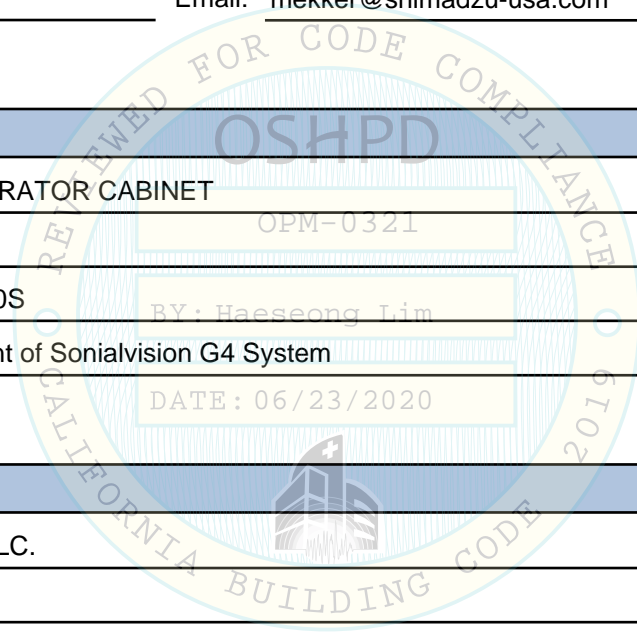



**OFFICE OF STATEWIDE HEALTH PLANNING AND DEVELOPMENT
FACILITIES DEVELOPMENT DIVISION**

Registered Design Professional Preparing Engineering Recommendations

Company Name: EASE LLC
Name: Jonathan Roberson California License Number: S4197
Mailing Address: 5877 Pine Ave., Suite 210, Chino Hills, CA 91709
Telephone: (909) 606-7622 Email: jon@easeco.com

OSHPD Special Seismic Certification Preapproval (OSP)

Special Seismic Certification is preapproved under OSP OSP Number: _____

Certification Method

Testing in accordance with: ICC-ES AC156 FM 1950-16
 Other(s) (Please Specify): _____

*Use of criteria other than those adopted by the California Building Standards Code, 2019 (CBSC 2019) for component supports and attachments are not permitted. For distribution system, interior partition wall, and suspended ceiling seismic bracings, test criteria other than those adopted in the CBSC 2019 may be used when approved by OSHPD prior to testing.

- Analysis
- Experience Data
- Combination of Testing, Analysis, and/or Experience Data (Please Specify): _____

OSHPD Approval

Date: 6/23/2020
Name: Haeseong Lim Title: Senior Structural Engineer
Condition of Approval (if applicable): _____

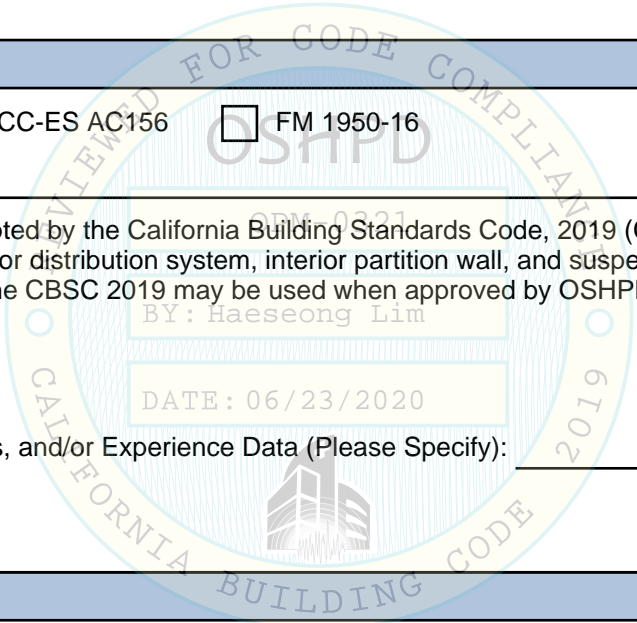



**EQUIPMENT ANCHORAGE
& SEISMIC ENGINEERING**

5877 Pine Ave, Ste. 210
Chino Hills, CA. 91709
Phn: (909) 606-7622

Office of Statewide Health Planning and Development
PREAPPROVAL OF MANUFACTURER'S CERTIFICATION
OPM-0321

THIS PREAPPROVAL CONFORMS TO THE 2019 CALIFORNIA BUILDING CODE

MANUFACTURER: **SHIMADZU MEDICAL SYSTEMS**
EQUIPMENT NAME: **D150BC-40S GENERATOR CABINET**

Sheet: 1 of 6
Date: 6/19/20

GENERAL NOTES

1. THIS OSHPD PREAPPROVAL OF MANUFACTURER'S CERTIFICATION (OPM) IS BASED ON THE 2019 CBC. THE DEMANDS (DESIGN FORCES) FOR USE WITH THIS OPM SHALL BE BASED ON THE 2019 CBC
2. THIS DOCUMENT MAY ONLY BE USED WITH THE EXPRESS WRITTEN CONSENT OF THE MANUFACTURER LISTED ABOVE FOR THE SPECIFIC PROJECT SITE AND INSTALLATION LOCATION. THIS DOCUMENT IS INVALID WITHOUT SUCH CONSENT.
3. THIS PREAPPROVAL CONFORMS TO THE 2019 CALIFORNIA BUILDING CODE WHERE S_Ds IS NOT GREATER THAN 1.75.
4. FORCES PER ASCE 7-16 SECTION 13.3.1, EQUATIONS 13.3-1, 13.3-2 & 13.3-3, WHERE $S_Ds = 1.75$, $a_p = 1.0$, $I_p = 1.5$, $R_p = 2.5$, $z/h = 0$ AT CONCRETE SLAB & $z/h \leq 1$ AT CONCRETE SLAB ON METAL DECK. SEE FOLLOWING SHEETS FOR Ω_o .
5. THIS PREAPPROVAL COVERS ONLY THE SUPPORTS AND ATTACHMENTS OF THE EQUIPMENT TO THE STRUCTURE.
6. ALL DESIGN FORCES SHOWN ON THE DRAWINGS ARE FACTORED LOADS THAT SHALL BE USED FOR STRENGTH DESIGN.
7. CONCRETE SLAB ON METAL DECK DETAIL VALID FOR DEMANDS SHOWN AT ANY ELEVATION IN THE BUILDING. (i.e. $z/h \leq 1$)
8. CONCRETE SLAB DETAIL VALID FOR DEMANDS SHOWN AT ANY ELEVATION AT OR BELOW GRADE. (i.e. $z/h = 0$)
9. SHEET METAL SCREWS SHALL BE TEKS SCREWS BY ITW BUILDEX (ICC ESR-1976).
10. **RESPONSIBILITIES OF THE STRUCTURAL ENGINEER OF RECORD OF THE BUILDING**
 - A. PROVIDE SUPPORTING STRUCTURE TO SUPPORT WEIGHTS AND FORCES SHOWN IN ADDITION TO ALL OTHER LOADS.
 - B. VERIFY THAT THE INSTALLATION IS IN CONFORMANCE WITH THE 2013 CBC AND WITH THE DETAILS, MATERIAL AND GAGE OF THE UNIT WHERE ATTACHMENTS ARE MADE AGREE WITH THE INFORMATION SHOWN ON THE PREAPPROVAL DOCUMENTS.
 - C. VERIFY THAT PROJECT SPECIFIC VALUES OF S_Ds & z/h RESULT IN SEISMIC FORCES (E_h , E_v) THAT DO NOT EXCEED THE VALUES ON THE DETAILS.
 - D. VERIFY THAT THE CONCRETE SLAB TO WHICH THE EQUIPMENT IS ANCHORED MEETS THE REQUIREMENTS OF THE APPLICABLE ICC ESR AND THIS OPM.
 - E. VERIFY THAT THE ANCHORS ARE AN ADEQUATE DISTANCE FROM ANY SLAB EDGES OR OPENINGS (SEE TYPICAL DETAIL ON SHEET 2).
 - F. VERIFY THAT ALL NEW OR EXISTING ANCHORS ARE AN ADEQUATE DISTANCE FROM THE UNIT ATTACHMENTS AND CHECK FOR INTERACTION WHERE OTHER ANCHORS ARE WITHIN 18" OR $6h_{ef}$ FROM THIS UNIT'S ANCHORS.



SHIMADZU MEDICAL SYSTEMS

DES. J. ROBERSON

SHEET

2

JOB NO. 11-1932

D150BC-40S GENERATOR CABINET

DATE 6/19/20

OF 6 SHEETS

11. EXPANSION ANCHORS:

A. ATTACHMENT IS TO BE MADE WITH THE ANCHORS LISTED BELOW AND INSTALLED AS DESCRIBED IN THE CORRESPONDING ICC REPORT.

Anchor Diameter	Concrete Type	Min. f'c (psi)	Anchor Type	ICC Report No.	Min. Embed.	Min. Spacing	Min. Edge Dist.	Min. Conc. Thickness	Torque Test	Direct Tension
1/2"	Normal Weight	3000	Hilti Kwik Bolt TZ	ESR-1917	2"	3"	9"	4"	40 FT-LB	1204 lb

B. THIS PREAPPROVAL ALLOWS FOR UP TO A MAXIMUM OF 2 ADJACENT CONCRETE SLAB EDGES, 9" AWAY MINIMUM (i.e. - CORNER). SEE ADJACENT DETAIL FOR ADDITIONAL MINIMUM ALLOWABLE CONCRETE EDGE DISTANCES.

C. TESTING AND SPECIAL INSPECTION OF EXPANSION ANCHORS SHALL BE PERFORMED BY AN APPROVED INDEPENDENT AGENCY EMPLOYED BY THE FACILITY OWNER PER CBC 1704A & 1910A.5 AND CAC 7-149. ALL REPORTS SHALL BE SENT TO THE INSPECTOR OF RECORD, OWNER AND THE ARCHITECT OR ENGINEER IN RESPONSIBLE CHARGE.

(i) AFTER AT LEAST 24 HOURS HAVE ELAPSED SINCE INSTALLATION, DIRECT PULL TENSION TEST AT LEAST 50% OF THE ANCHORS.

(ii) ACCEPTANCE CRITERIA:

- DIRECT TENSION TEST: THE ANCHOR SHOULD HAVE NO OBSERVABLE MOVEMENT AT THE TEST LOAD. A PRACTICAL WAY TO DETERMINE OBSERVABLE MOVEMENT IS THAT THE WASHER BECOMES LOOSE.
- TORQUE TEST: THE APPLICABLE TORQUE MUST BE ACHIEVED WITHIN THE FOLLOWING LIMITS: WEDGE TYPE: 1/2 TURN OF THE NUT

(iii) IF ANY ANCHOR FAILS, TEST ALL ANCHORS.

D. AVOID DAMAGING EXISTING STEEL REINFORCING IN CONCRETE SLAB WHEN INSTALLING CONCRETE EXPANSION ANCHORS.

E. PROVIDE FOR FULL THREAD ENGAGEMENT OF NUT & WASHER.

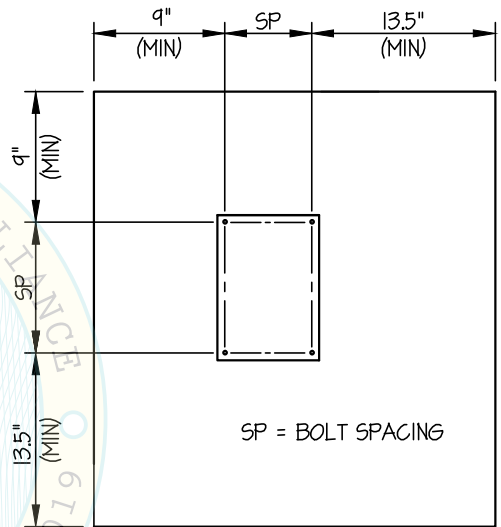

TYPICAL CONCRETE EDGE DETAIL



SHIMADZU MEDICAL SYSTEMS

D150BC-40S GENERATOR CABINET

DES. J. ROBERSON

JOB NO. 11-1932

DATE 6/19/20

SHEET

3

OF 6 SHEETS

SEISMIC SUPPORTS & ATTACHMENTS

CONCRETE SLAB / CONCRETE SLAB ON METAL DECK

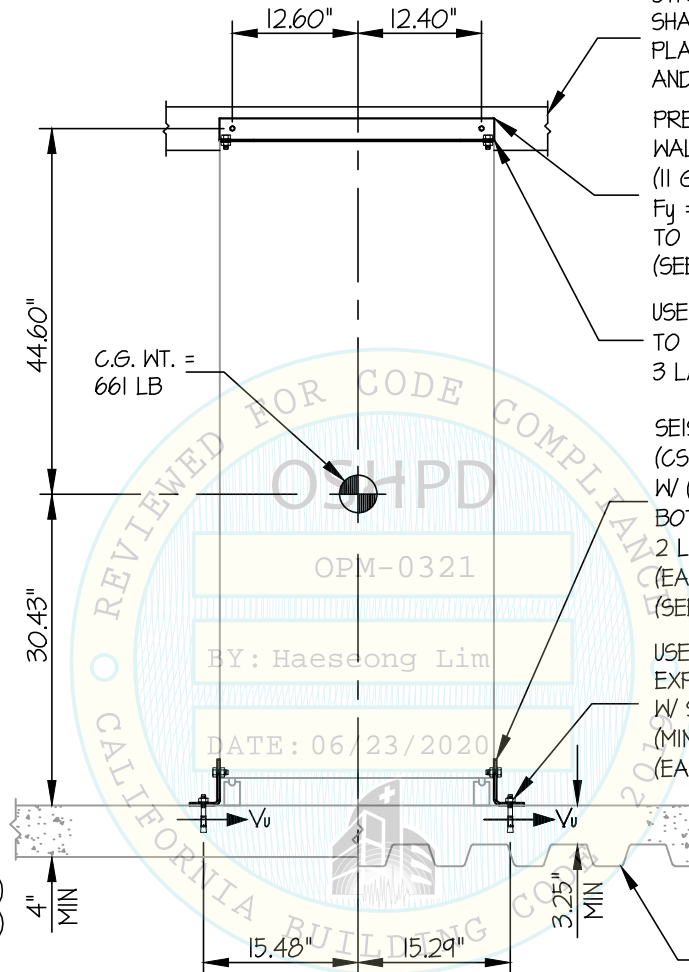

STRUCTURAL ENGINEER OF RECORD SHALL DESIGN THE BACKING PLATE (16 GA., 50 KSI MIN.) AND THE WALL STRUCTURE

PRE-MANUFACTURED WALL BRACKET (BY SHIMADZU) (11 GA, ASTM A1008 LOW CRS, Fy = 20 KSI) W/ 2- 1/4"Φ TEK SCREWS TO BACKING PLATE (SEE WALL BRACKET DETAIL "A")

USE (2)- M12 (CLASS 8.8 MIN) BOLT TO TOP UNIT FRAME (0.217" THK TOTAL, 3 LAYERS CRS Fy=23 KSI)

SEISMIC BRACKET (BY SHIMADZU) (CS HRS 0.25 ASTM A36) W/ (4) - 3/8"Φ (GR 5) CAP SCREW TO BOTTOM UNIT FRAME (0.153" THK TOTAL, 2 LAYERS CR STEEL Fy=23 KSI) (EA BRACKET 4 PLACES, 8 TOTAL) (SEE SEISMIC BRACKET DETAIL "B")

USE 2- 1/2" HILTI KB-TZ EXPANSION ANCHORS W/ STANDARD WASHER (MIN. EMBED. (h_{ef}) = 2") (EA BRACKET 2 PLACES, 4 TOTAL)

AT CONCRETE SLAB NORMAL WEIGHT CONCRETE (f'c = 3000 PSI MIN) AT OR BELOW GRADE LEVEL OR AT CONCRETE SLAB ON METAL DECK N.W. OR SAND L.W. (f'c = 3000 PSI MIN)

T_{U WALL} = 216 LB/SCREW (MAX)
 V_{U WALL} = 169 LB/SCREW (MAX)
 V_{U FLOOR} = 348 LB/BOLT (MAX)
 (V_{U FLOOR} INCLUDES Ω)

FRONT ELEVATION

NOTES:

- FORCES ARE DETERMINED PER 2019 CALIFORNIA BUILDING CODE AND ASCE 7-16.

STRENGTH DESIGN IS USED. (S_{Ds} = 1.75, α_p = 1.0, I_p = 1.5, R_p = 2.5, Ω_o = 2.0, z/h ≤ 1)

HORIZONTAL FORCE (E_h) = 1.26 W_p

HORIZONTAL FORCE (E_{mh}) = 2.52 W_p (FOR CONCRETE ANCHORAGE)

VERTICAL FORCE (E_v) = 0.35 W_p

- CENTER OF GRAVITY (C.G.) AND WEIGHT ARE THE GOVERNING PARAMETERS FOR DESIGN. THIS PREAPPROVAL ENCOMPASSES ALL WEIGHTS UP TO THE MAXIMUM WEIGHT SHOWN.

- STRUCTURAL ENGINEER OF RECORD FOR THE BUILDING SHALL PROVIDE SUPPORT STRUCTURE DESIGNED TO SUPPORT WEIGHTS AND FORCES SHOWN IN COMBINATION WITH ALL OTHER LOADS THAT MAY BE PRESENT.

- SEE GENERAL NOTES: SHEET 1 AND 2



SHIMADZU MEDICAL SYSTEMS

D150BC-40S GENERATOR CABINET

DES. **J. ROBERSON**

JOB NO. **11-1932**

DATE **6/19/20**

SHEET

4

OF **6** SHEETS

SEISMIC SUPPORTS & ATTACHMENTS

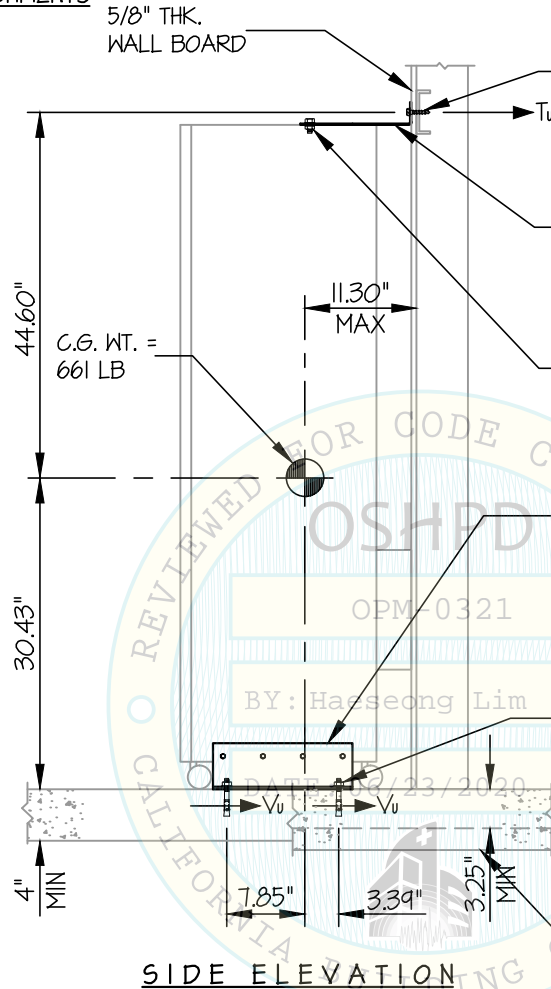

CONCRETE SLAB / CONCRETE SLAB ON METAL DECK

STRUCTURAL ENGINEER OF RECORD SHALL DESIGN THE BACKING PLATE (16 GA., 50 KSI MIN.) AND THE WALL STRUCTURE

PRE-MANUFACTURED WALL BRACKET (BY SHIMADZU) (11 GA, ASTM A1008 LOW CRS, Fy = 20 KSI) W/ 2- 1/4"Φ TEK SCREWS TO BACKING PLATE (SEE WALL BRACKET DETAIL "A")

USE (2)- M12 (CLASS 8.8 MIN) BOLT TO TOP UNIT FRAME (0.217" THK TOTAL, 3 LAYERS CRS Fy=23 KSI)

SEISMIC BRACKET (BY SHIMADZU) (CS HRS 0.25 ASTM A36) W/ (4) - 3/8"Φ (GR 5) CAP SCREW TO BOTTOM UNIT FRAME (0.153" THK TOTAL, 2 LAYERS CR STEEL Fy=23 KSI) (EA BRACKET 4 PLACES, 8 TOTAL) (SEE SEISMIC BRACKET DETAIL "B")

USE 2- 1/2" HILTI KB-TZ EXPANSION ANCHORS W/ STANDARD WASHER (MIN. EMBED, (net) = 2") (EA BRACKET 2 PLACES, 4 TOTAL)

AT CONCRETE SLAB
NORMAL WEIGHT CONCRETE
(f'c = 3000 PSI MIN)
AT OR BELOW GRADE LEVEL

OR
AT CONCRETE SLAB ON METAL DECK
N.W. OR SAND L.W.
(f'c = 3000 PSI MIN)

SIDE ELEVATION

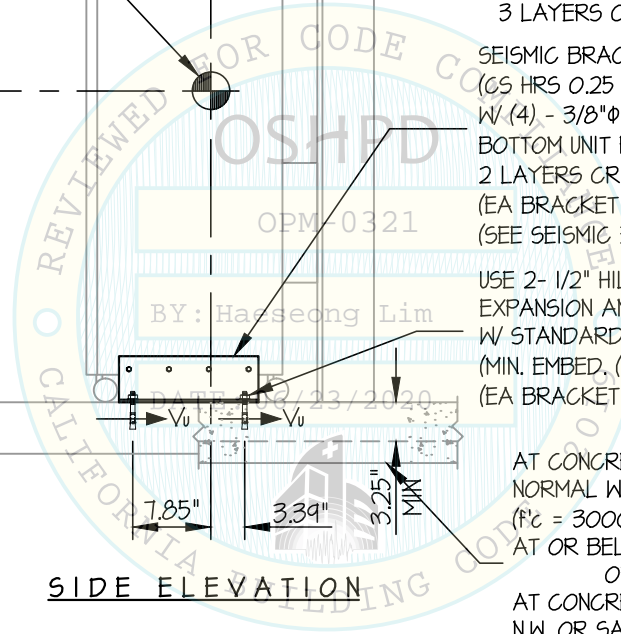

Jonathan Roberson
 REGISTERED PROFESSIONAL ENGINEER
 JONATHAN ROBERSON
 No. 4197
 EXP. 6-30-2020
 6/19/20
 STRUCTURAL
 STATE OF CALIFORNIA

SHIMADZU MEDICAL SYSTEMS

DES. J. ROBERSON

SHEET

5

JOB NO. 11-1932

OF 6

SHEETS

D150BC-40S GENERATOR CABINET

DATE 6/19/20

SEISMIC SUPPORTS & ATTACHMENTS

BRACKET DETAIL

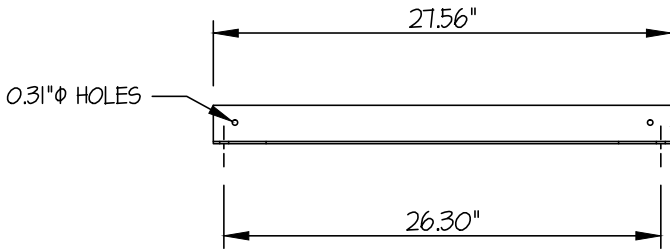

BRACKET SUPPLIED BY SHIMADZU
(11 GA, ASTM A36 LOW CRS)

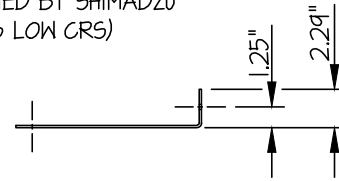

ELEVATION

SIDE

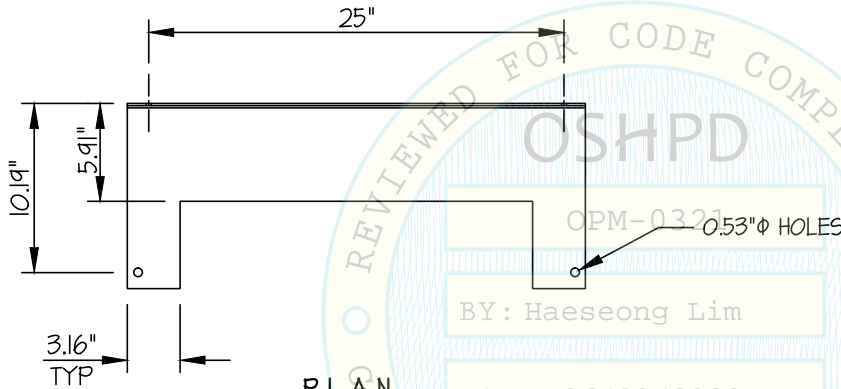

PLAN

WALL BRACKET DETAIL (A)

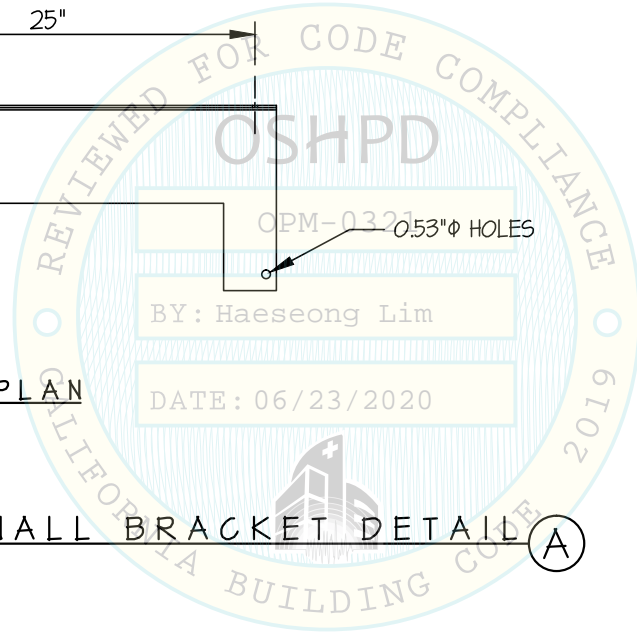

SHIMADZU MEDICAL SYSTEMS

DES. J. ROBERSON

SHEET

6

D150BC-40S GENERATOR CABINET

JOB NO. 11-1932

DATE 6/19/20

OF 6 SHEETS

SEISMIC SUPPORTS & ATTACHMENTS

BRACKET DETAIL

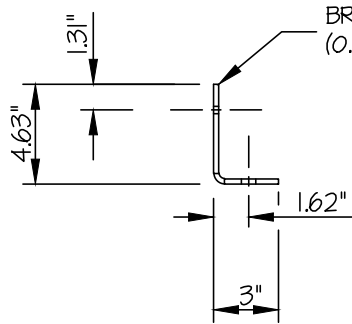

SIDE

BRACKET SUPPLIED BY SHIMADZU
(0.25" THK ASTM A36 LOW CRS)

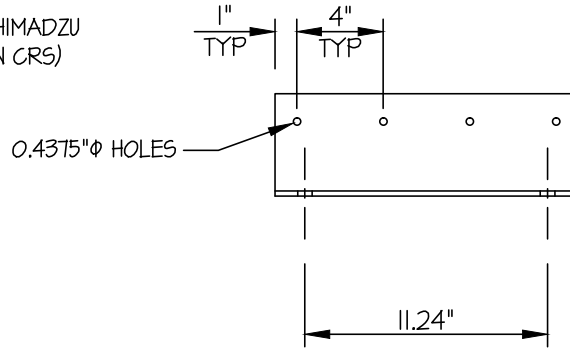

ELEVATION

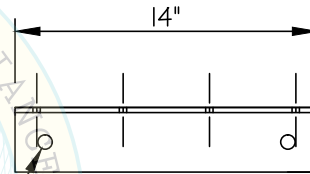

PLAN

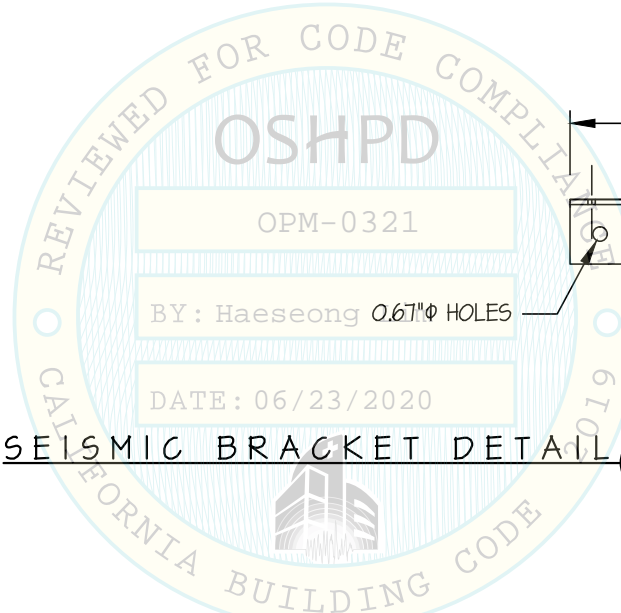

SEISMIC BRACKET DETAIL (B)

