



OFFICE OF STATEWIDE HEALTH PLANNING AND DEVELOPMENT
FACILITIES DEVELOPMENT DIVISION

APPLICATION FOR OSHPD PREAPPROVAL
OF MANUFACTURER'S CERTIFICATION (OPM)

OFFICE USE ONLY
APPLICATION #: OPM-0342-13

OSHPD Preapproval of Manufacturer's Certification (OPM)

Type: [X] New [] Renewal [] Update to Pre-CBC 2013 OPA Number:

Manufacturer Information

Manufacturer: MAVIG CORPORATION

Manufacturer's Technical Representative: Ben Wiesenberg

Mailing Address: 22 Hytec Circle, Rochester, NY. 14606

Telephone: On File Email: On File

Product Information

Product Name: GD60 Monitor Support

Product Type: Cantilevered Element

Product Model Number: GD60

General Description: Ceiling supported monitor arm system

Applicant Information

Applicant Company Name: EASE Co.

Contact Person: Jonathan Roberson, S.E.

Mailing Address: 5877 Pine Ave. Suite 210, Chino Hills, CA. 91709

Telephone: (909) 606-7622 Email: J.Roberson@EASECo.com

I hereby agree to reimburse the Office of Statewide Health Planning and Development review fees in accordance with the California Administrative Code, 2016.

Signature of Applicant: [Signature] Date: 4/19/16

Title: Principal Engineer Company Name: EASE Co.

"Access to Safe, Quality Healthcare Environments that Meet California's Diverse and Dynamic Needs"





**OFFICE OF STATEWIDE HEALTH PLANNING AND DEVELOPMENT
FACILITIES DEVELOPMENT DIVISION**

Registered Design Professional Preparing Engineering Recommendations

Company Name: EASE Co.

Name: Jonathan Roberson, S.E. California License Number: S4197

Mailing Address: 5877 Pine Ave. Suite 210, Chino Hills, CA. 91709

Telephone: 909-606-7622 Email: J.Roberson@EASECo.com

OSHPD Special Seismic Certification Preapproval (OSP)

- Special Seismic Certification is preapproved under OSP-
(Separate application for OSP is required)
- Special Seismic Certification is not preapproved

Certification Method(s)

- Testing in accordance with: ICC-ES AC156 FM 1950-16
- Other* (Please Specify): _____

*Use of criteria other than those adopted by the California Building Standards Code, 2016 (CBSC 2016) for component supports and attachments are not permitted. For distribution system, interior partition wall, and suspended ceiling seismic bracings, test criteria other than those adopted in the CBSC 2016 may be used when approved by OSHPD prior to testing.

- Analysis
- Experience Data
- Combination of Testing, Analysis, and/or Experience Data (Please Specify): _____

List of Attachments Supporting the Manufacturer's Certification

- Test Report Drawings Calculations Manufacturer's Catalog
- Other(s) (Please Specify): _____

OFFICE USE ONLY – OSHPD APPROVAL VALID FOR CBC 2016 & ALL PRE-2016 CODE BASED PROJECTS

Signature: *William Staehlin* Date: 11-06-2017

Print Name: William Staehlin

Title: SSE

Condition of Approval (if applicable): _____

"Access to Safe, Quality Healthcare Environments that Meet California's Diverse and Dynamic Needs"





**EQUIPMENT ANCHORAGE
& SEISMIC ENGINEERING**

5877 Pine Ave, Ste. 210
Chino Hills, CA. 91709
Phn: (909) 606-7622

Office of Statewide Health Planning and Development
PREAPPROVAL OF MANUFACTURER'S CERTIFICATION
OPM-0342-13

THIS PREAPPROVAL CONFORMS TO THE 2016 CALIFORNIA BUILDING CODE

MANUFACTURER: **MAVIG**
EQUIPMENT NAME: **GD60 DOUBLE ARM SUSPENSION**

Sheet: 1 of 9
Date: 8/7/17

GENERAL NOTES

1. THIS OSHPD PREAPPROVAL OF MANUFACTURER'S CERTIFICATION (OPM) IS BASED ON THE 2016 CBC. THE DEMANDS (DESIGN FORCES) FOR USE WITH THIS OPM SHALL BE BASED ON THE 2016 CBC
2. THIS DOCUMENT MAY ONLY BE USED WITH THE EXPRESS WRITTEN CONSENT OF THE MANUFACTURER LISTED ABOVE FOR THE SPECIFIC PROJECT SITE AND INSTALLATION LOCATION. THIS DOCUMENT IS INVALID WITHOUT SUCH CONSENT.
3. THIS PREAPPROVAL CONFORMS TO THE 2016 CALIFORNIA BUILDING CODE WHERE S_{Ds} IS NOT GREATER THAN 2.20.
4. FORCES PER ASCE 7-10 SECTION 13.3.1, EQUATIONS 13.3-1, 13.3-2 & 13.3-3, WHERE $S_{Ds} = 2.20$, $a_p = 2.5$, $I_p = 1.5$, $R_p = 2.5$, $z/h \leq 1$ AT CONCRETE SLAB ON METAL DECK. SEE FOLLOWING SHEETS FOR Ω_0 .
5. THIS PREAPPROVAL COVERS ONLY THE SUPPORTS AND ATTACHMENTS OF THE EQUIPMENT TO THE STRUCTURE.
6. ALL DESIGN FORCES SHOWN ON THE DRAWINGS ARE FACTORED LOADS THAT SHALL BE USED FOR STRENGTH DESIGN.
7. **RESPONSIBILITIES OF THE STRUCTURAL ENGINEER OF RECORD OF THE BUILDING**
 - A. PROVIDE SUPPORTING STRUCTURE TO SUPPORT WEIGHTS AND FORCES SHOWN IN ADDITION TO ALL OTHER LOADS.
 - B. VERIFY THAT THE INSTALLATION IS IN CONFORMANCE WITH THE 2016 CBC AND WITH THE DETAILS, MATERIAL AND GAGE OF THE UNIT WHERE ATTACHMENTS ARE MADE AGREE WITH THE INFORMATION SHOWN ON THE PREAPPROVAL DOCUMENTS.
 - C. VERIFY THAT PROJECT SPECIFIC VALUES OF S_{Ds} & z/h RESULT IN SEISMIC FORCES (E_h , E_v) THAT DO NOT EXCEED THE VALUES ON THE DETAILS.
 - D. VERIFY THAT THE CONCRETE SLAB TO WHICH THE EQUIPMENT IS ANCHORED MEETS THE REQUIREMENTS OF THE APPLICABLE ICC ESR.
 - E. VERIFY THAT THE ANCHORS ARE AN ADEQUATE DISTANCE FROM ANY SLAB EDGES OR OPENINGS (SEE TYPICAL DETAIL ON SHEET 2).
 - F. VERIFY THAT ALL NEW OR EXISTING ANCHORS ARE AN ADEQUATE DISTANCE FROM THE UNIT ATTACHMENTS AND CHECK FOR INTERACTION WHERE OTHER ANCHORS ARE WITHIN 18" OR $6h_{ef}$ FROM THIS UNIT'S ANCHORS.



MAVIG

GD60 DOUBLE ARM SUSPENSION

DES. **J. ROBERSON**

JOB NO. **11-1530**

DATE **8/7/17**

SHEET

2

OF

9

SHEETS

8. EXPANSION ANCHORS:

A. ATTACHMENT IS TO BE MADE WITH THE ANCHORS LISTED BELOW AND INSTALLED AS DESCRIBED IN THE CORRESPONDING ICC REPORT.

Anchor Diameter	Concrete Type	Min. f'c (psi)	Anchor Type	ICC Report No.	Min. Embed.	Min. Spacing	Min. Edge Dist.	Min. Conc. Over Flutes	Torque Test	Direct Tension Test
1/2"	Sand Light Weight	3000	Hilti Kwik Bolt TZ	ESR-1917	3.25"	9.75"	24"	3.25"	40 FT-LB	N/A
5/8"	Sand Light Weight	3000	Hilti Kwik Bolt TZ	ESR-1917	4"	12"	24"	3.25"	60 FT-LB	N/A

B. THIS PREAPPROVAL ALLOWS FOR UP TO A MAXIMUM OF 2 ADJACENT CONCRETE SLAB EDGES, 24" AWAY MINIMUM (i.e. - CORNER). SEE ADJACENT DETAIL FOR ADDITIONAL MINIMUM ALLOWABLE CONCRETE EDGE DISTANCES.

C. TESTING OF EXPANSION ANCHORS PER 2016 CBC, 1910A.5: TESTING SHALL BE DONE IN THE PRESENCE OF THE SPECIAL INSPECTOR AND A REPORT OF THE TEST RESULTS SHALL BE SUBMITTED TO OSHPD

(i) AFTER AT LEAST 24 HOURS HAVE ELAPSED SINCE INSTALLATION, DIRECT PULL TENSION TEST OR TORQUE TEST AT LEAST 50% OF THE ANCHORS.

(ii) ACCEPTANCE CRITERIA:

- DIRECT TENSION TEST: THE ANCHOR SHOULD HAVE NO OBSERVABLE MOVEMENT AT THE TEST LOAD. A PRACTICAL WAY TO DETERMINE OBSERVABLE MOVEMENT IS THAT THE WASHER BECOMES LOOSE.
- TORQUE TEST: THE APPLICABLE TORQUE MUST BE ACHIEVED WITHIN THE FOLLOWING LIMITS: WEDGE TYPE : 1/2 TURN OF THE NUT

(iii) IF ANY ANCHOR FAILS, TEST ALL ANCHORS.

D. AVOID DAMAGING EXISTING STEEL REINFORCING IN CONCRETE SLAB WHEN INSTALLING CONCRETE EXPANSION ANCHORS.

E. PROVIDE FOR FULL THREAD ENGAGEMENT OF NUT & WASHER.



MAVIG

DES. **J. ROBERSON**

SHEET

3

JOB NO. **11-1530**

GD60 DOUBLE ARM SUSPENSION

DATE **8/7/17**

OF **9** SHEETS

SEISMIC SUPPORTS & ATTACHMENTS

CEILING MOUNTED

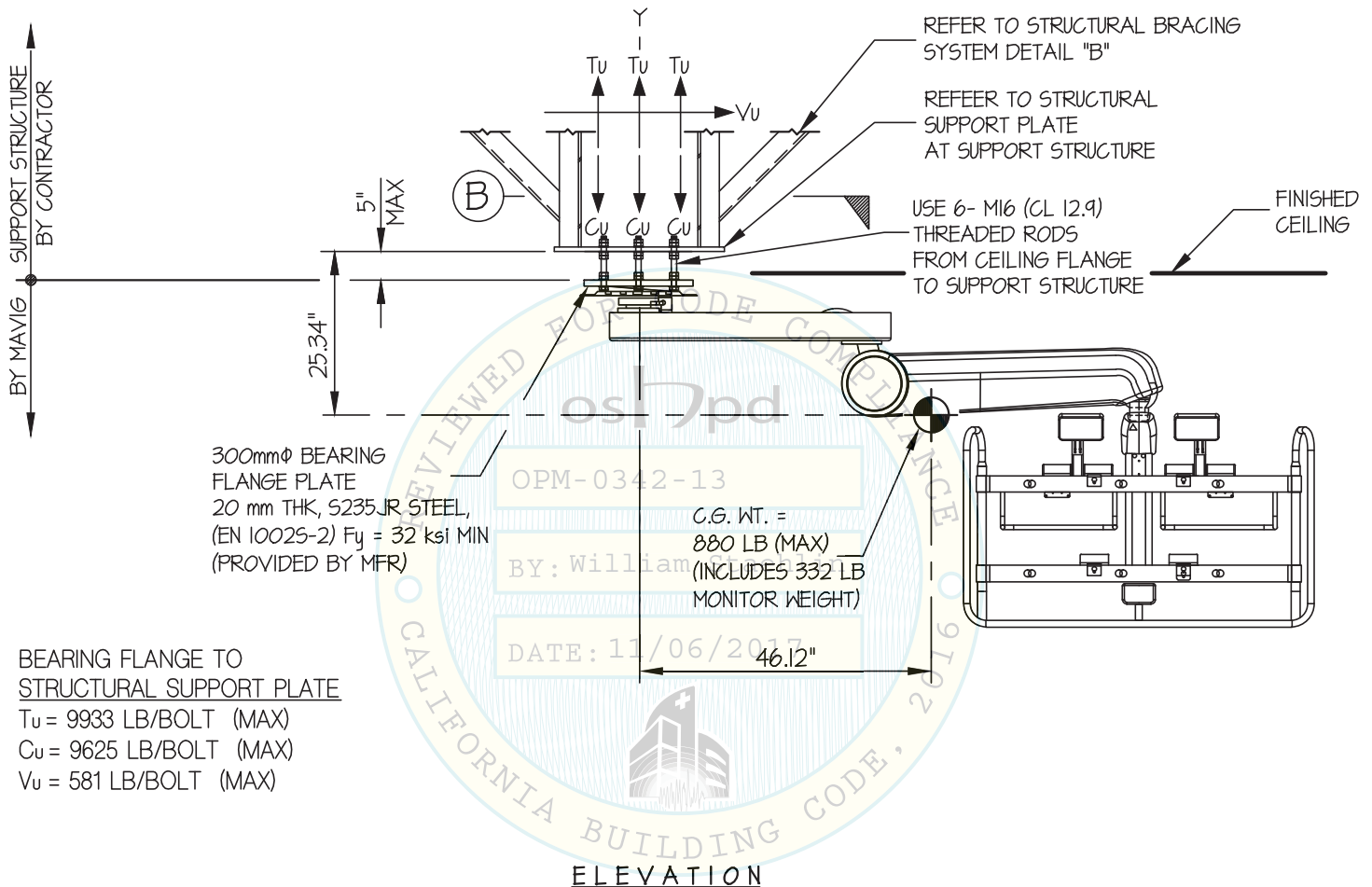

NOTES:

1. **FORCES ARE DETERMINED PER 2016 CALIFORNIA BUILDING CODE AND ASCE 7-10.**

STRENGTH DESIGN IS USED. ($S_{ds} = 2.20$, $a_p = 2.5$, $I_p = 1.5$, $R_p = 2.5$, $\Omega_o = 2.5$, $z/h \leq 1$)

HORIZONTAL FORCE (E_h) = $3.96 W_p$

VERTICAL FORCE (E_v) = $0.44 W_p$

2. CENTER OF GRAVITY (C.G.) AND WEIGHT ARE THE GOVERNING PARAMETERS FOR DESIGN. THIS PREAPPROVAL ENCOMPASSES ALL WEIGHTS UP TO THE MAXIMUM WEIGHT SHOWN.

3. STRUCTURAL ENGINEER OF RECORD FOR THE BUILDING SHALL PROVIDE SUPPORT STRUCTURE DESIGNED TO SUPPORT WEIGHTS AND FORCES SHOWN IN COMBINATION WITH ALL OTHER LOADS THAT MAY BE PRESENT.



MAVIG

DES. J. ROBERSON

SHEET

4

JOB NO. 11-1530

GD60 DOUBLE ARM SUSPENSION

DATE 8/7/17

OF 9 SHEETS

SEISMIC SUPPORTS & ATTACHMENTS

CEILING FLANGE TO STRUCTURAL SUPPORT PLATE

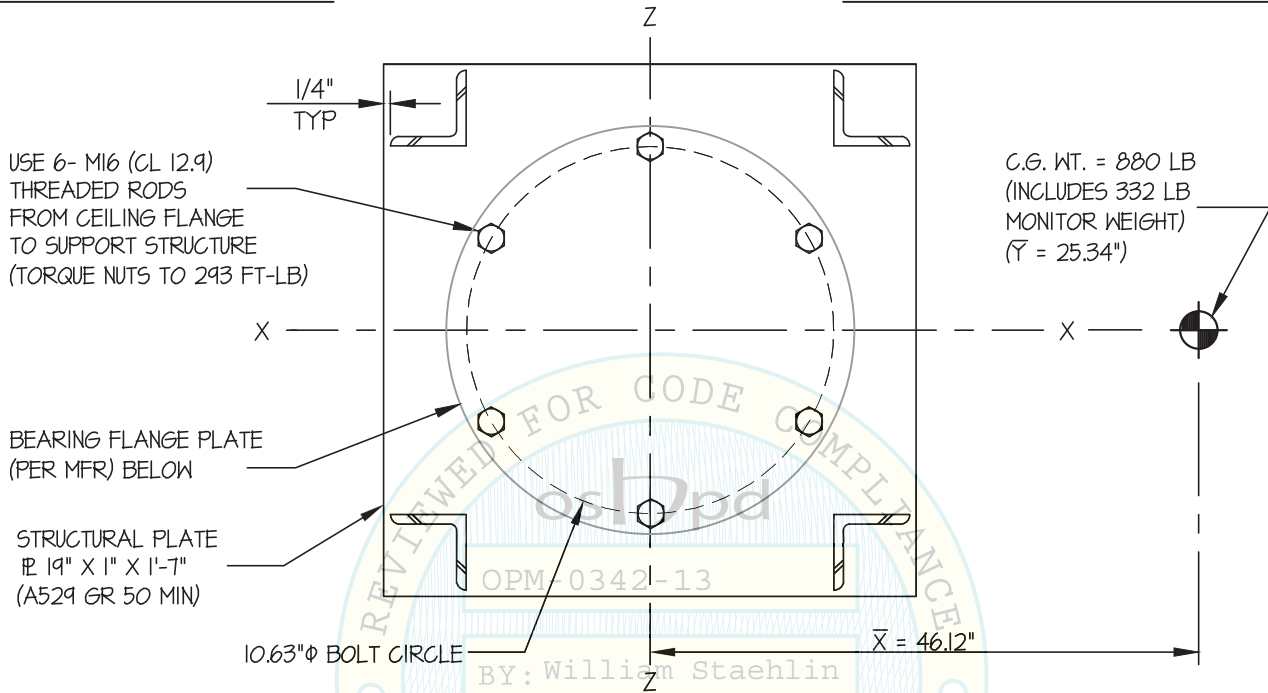

PLAN AT STRUCTURAL PLATE

DATE: 11/06/2017



MAVIG

GD60 DOUBLE ARM SUSPENSION

DES. **J. ROBERSON**

JOB NO. **11-1530**

DATE **8/7/17**

SHEET

5

OF **9** SHEETS

SEISMIC SUPPORTS & ATTACHMENTS

BRACING DETAILS

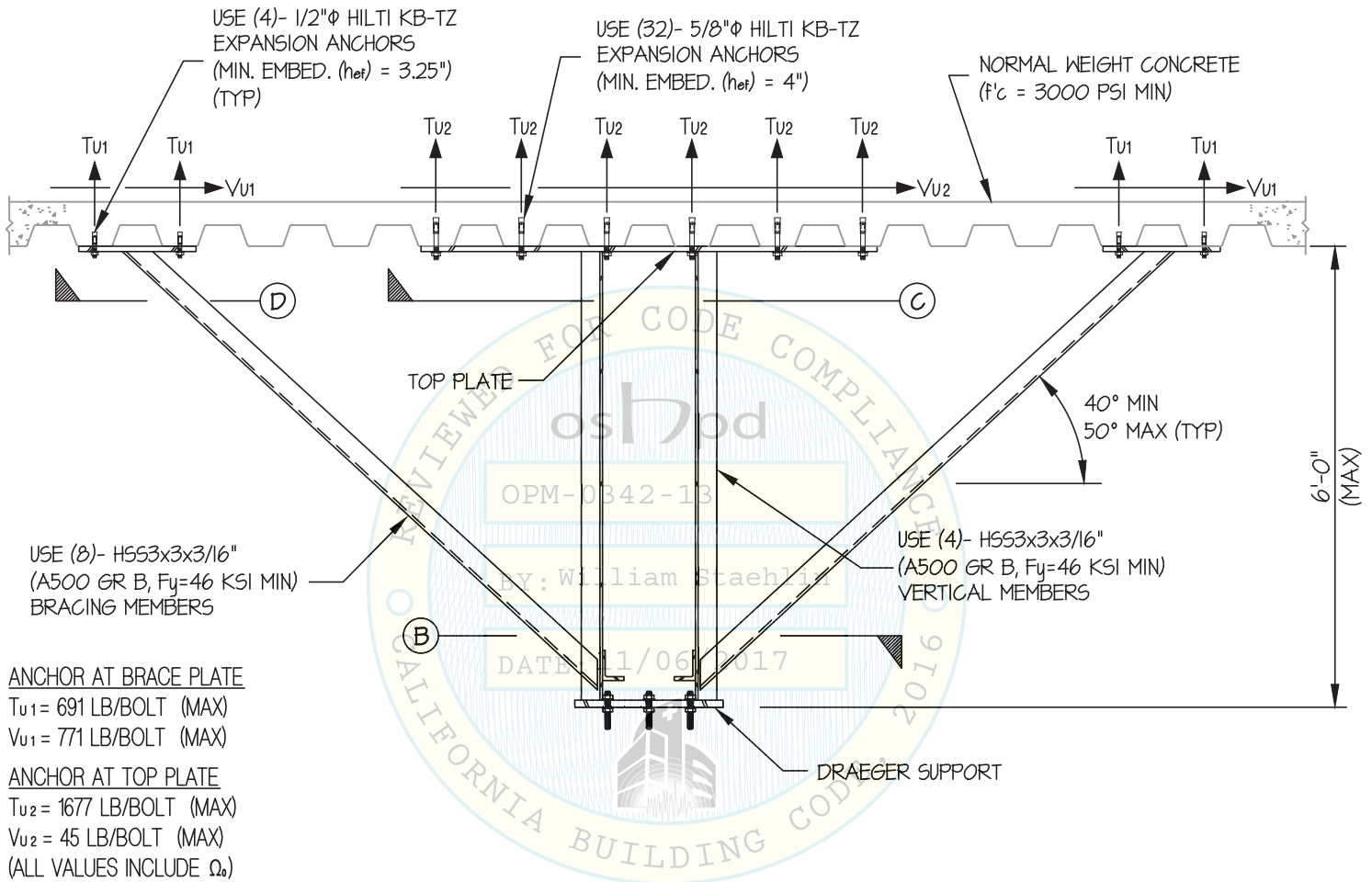

ANCHOR AT BRACE PLATE

T_{u1} = 691 LB/BOLT (MAX)
V_{u1} = 771 LB/BOLT (MAX)

ANCHOR AT TOP PLATE

T_{u2} = 1677 LB/BOLT (MAX)
V_{u2} = 45 LB/BOLT (MAX)
(ALL VALUES INCLUDE Ω_b)

STRUCTURAL BRACING DETAIL **(A)**



MAVIG

DES. J. ROBERSON

SHEET

6

JOB NO. 11-1530

GD60 DOUBLE ARM SUSPENSION

DATE 8/7/17

OF 9 SHEETS

SEISMIC SUPPORTS & ATTACHMENTS

BRACING DETAILS

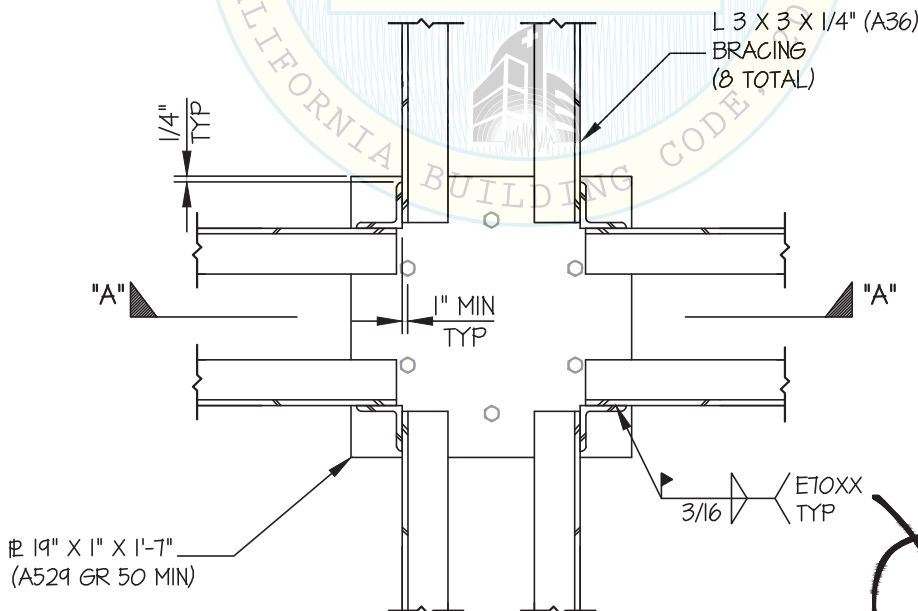
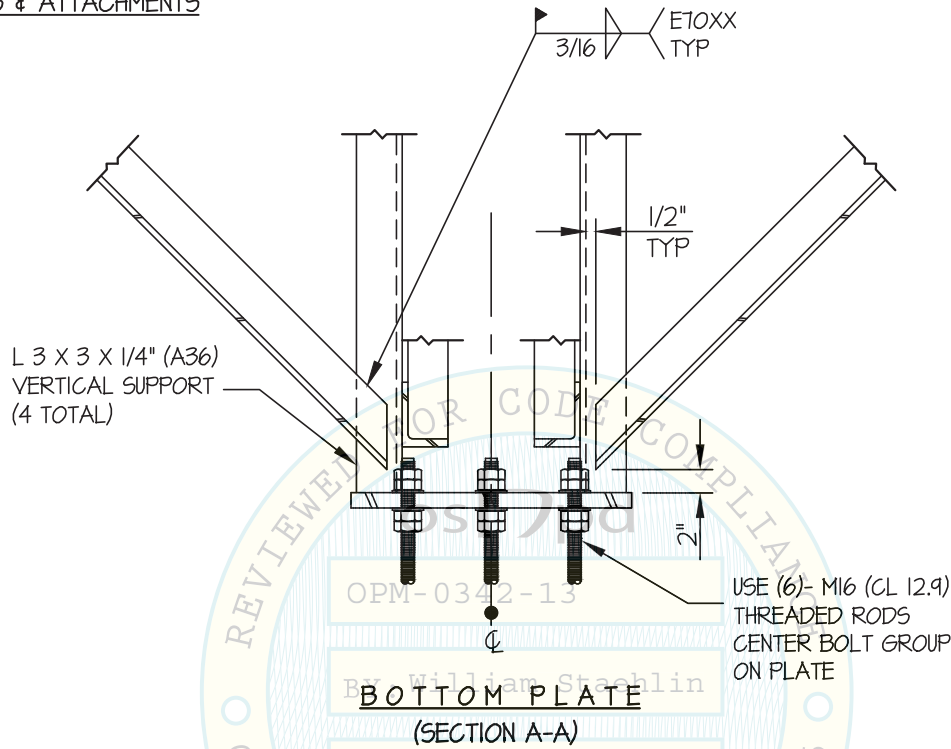

Jonathan Roberson

REGISTERED PROFESSIONAL ENGINEER
 JONATHAN ROBERSON
 No. 4197
 EXP. 6-30-2018
 8/7/17
 STRUCTURAL
 STATE OF CALIFORNIA

MAVIG

DES. **J. ROBERSON**

SHEET

7

JOB NO. **11-1530**

GD60 DOUBLE ARM SUSPENSION

DATE **8/7/17**

OF **9** SHEETS

SEISMIC SUPPORTS & ATTACHMENTS

BRACING DETAILS

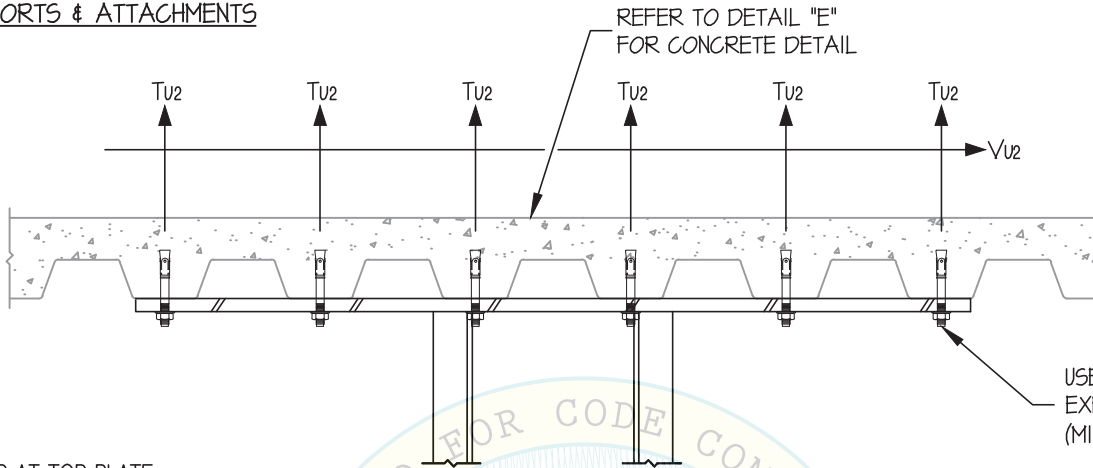

ANCHOR AT TOP PLATE
T_{u2} = 1677 LB/BOLT (MAX)
V_{u2} = 45 LB/BOLT (MAX)
(VALUES INCLUDE Ω_e)

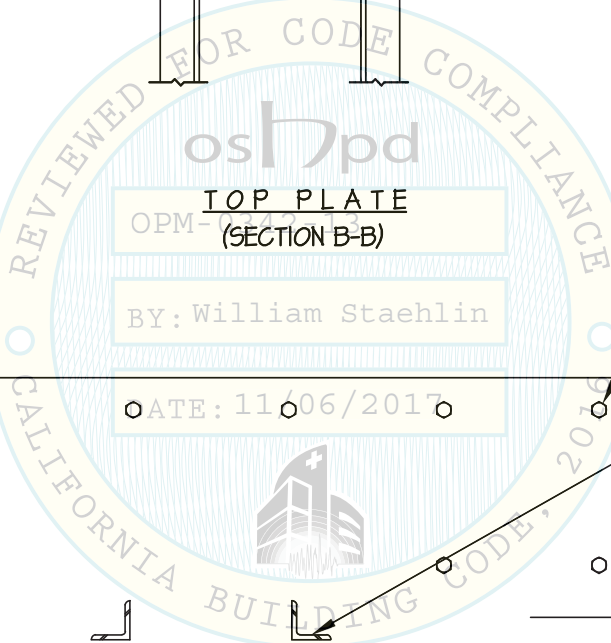

TOP PLATE (SECTION B-B)

USE (24)- 5/8"φ HILTI KB-TZ EXPANSION ANCHORS (MIN. EMBED. (h_{ef}) = 4")

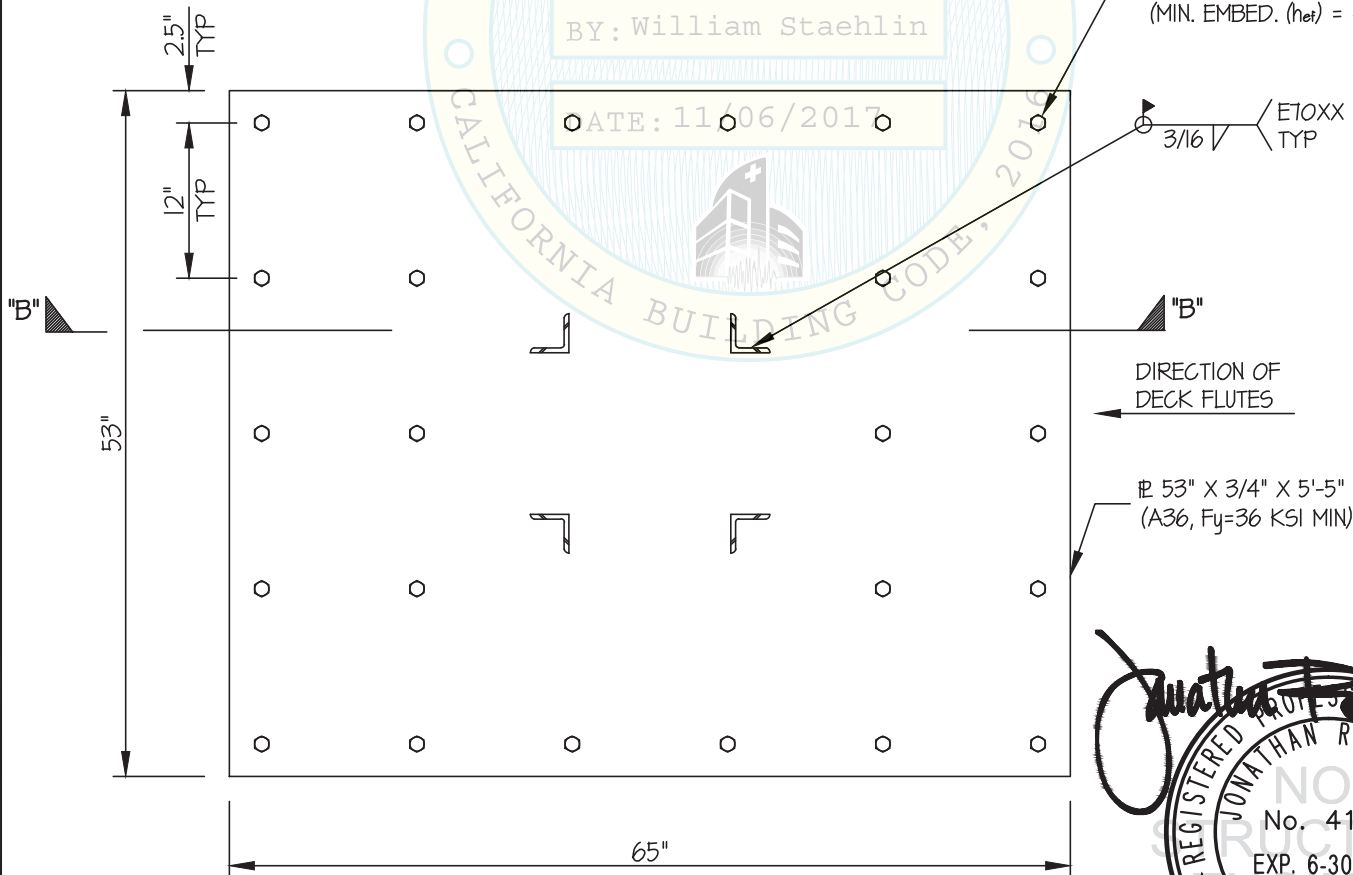

TOP PLATE DETAIL (C)



MAVIG

DES. J. ROBERSON

SHEET

8

JOB NO. 11-1530

GD60 DOUBLE ARM SUSPENSION

DATE 8/7/17

OF 9 SHEETS

SEISMIC SUPPORTS & ATTACHMENTS

BRACING DETAILS

USE (4)- 1/2"φ HILTI KB-TZ
EXPANSION ANCHORS
(MIN. EMBED. (h_{ef}) = 3.25")
W/ STANDARD WASHERS

3/8"φ (A36, MIN)

BRACING MEMBER
(ORIENTATION MAY VARY)
CENTERED ON PLATE

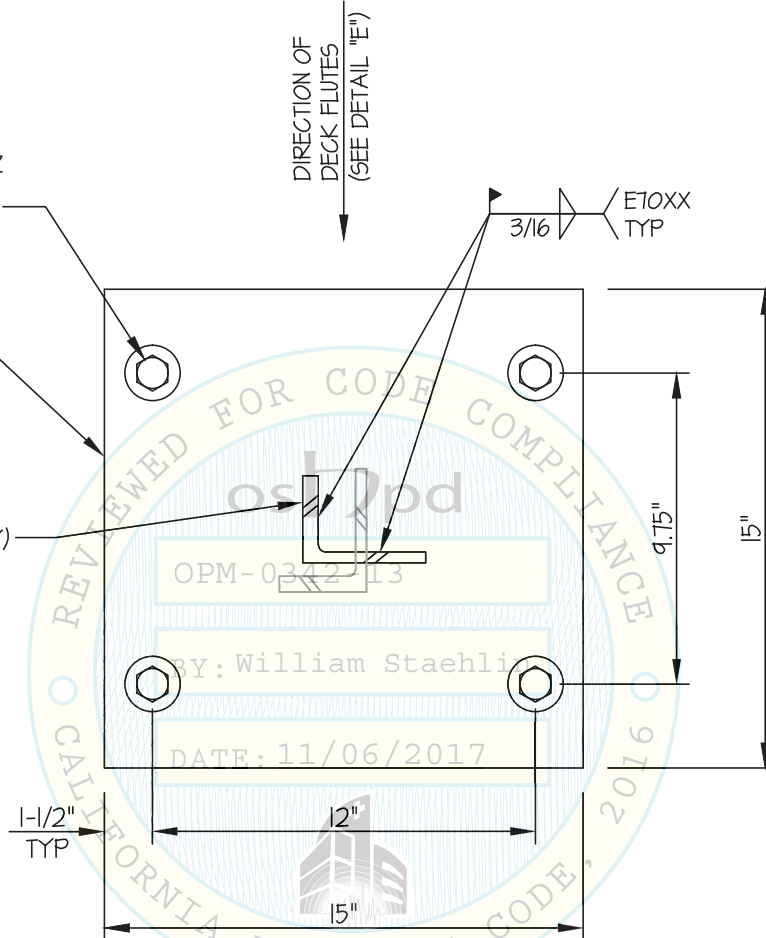

BRACE PLATE DETAIL (D)

ANCHOR AT BRACE PLATE

T_{u1} = 691 LB/BOLT (MAX)

V_{u1} = 771 LB/BOLT (MAX)



MAVIG

GD60 DOUBLE ARM SUSPENSION

DES. **J. ROBERSON**

JOB NO. **11-1530**

DATE **8/7/17**

SHEET

9

OF **9** SHEETS

SEISMIC SUPPORTS & ATTACHMENTS

BRACING DETAILS

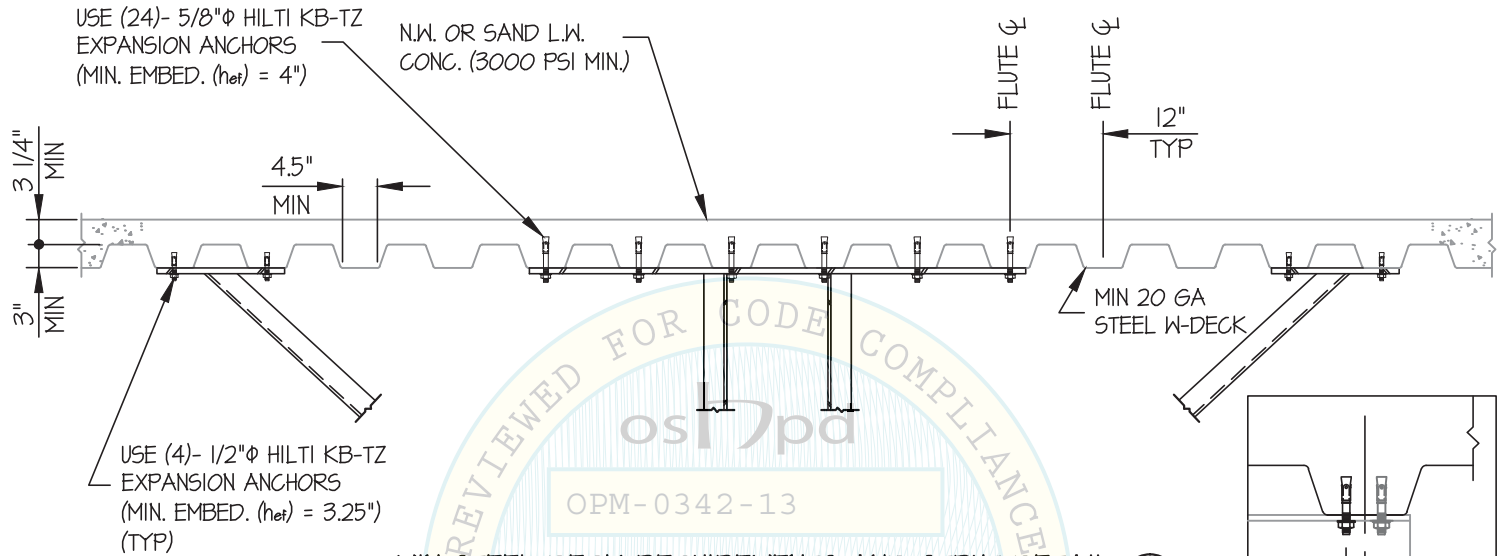

MIN STEEL DECK REQUIREMENTS AND STRUT DETAIL (E)

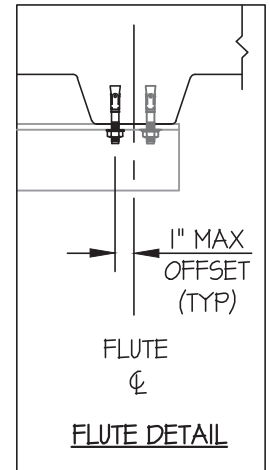

Jonathan Roberson
 REGISTERED PROFESSIONAL ENGINEER
 JONATHAN ROBERSON
 No. 4197
 EXP. 6-30-2018
 8/7/17
 STRUCTURAL
 STATE OF CALIFORNIA