



OFFICE OF STATEWIDE HEALTH PLANNING AND DEVELOPMENT
FACILITIES DEVELOPMENT DIVISION

APPLICATION FOR OSHPD PREAPPROVAL OF MANUFACTURER'S CERTIFICATION (OPM)

OFFICE USE ONLY
APPLICATION #: OPM-0351-13

OSHPD Preapproval of Manufacturer's Certification (OPM)

Type: [X] New [] Renewal [X] Update to Pre-CBC 2013 OPA Number: OPA-2804-10

Manufacturer Information

Manufacturer: Anvil International, LLC
Manufacturer's Technical Representative: Gregory Ohnemus
Mailing Address: 160 Frenchtown Road, North Kingstown, RI 02852
Telephone: (401) 558-2584 Email: gohnmus@anvilintl.com

Product Information

Product Name: Seismic Sway Bracing for Fire Protection Systems
Product Type: Seismic Sway Bracing OPM-0351-13
Product Model Number: Figures 770, 771, 772, 775, 776, and 778
General Description: Pipe clamp & brace pipe supports, & attachment of supports to wood, steel & conc. structure

Applicant Information

Applicant Company Name: Anvil International
Contact Person: Gregory Ohnemus
Mailing Address: 160 Frenchtown Road, North Kingston, RI 02852
Telephone: (401) 558-2584 Email: gohnmus@anvilintl.com

I hereby agree to reimburse the Office of Statewide Health Planning and Development review fees in accordance with the California Administrative Code, 2016.

Signature of Applicant: [Handwritten Signature] Date: 05/26/2016
Title: Product Engineer Company Name: Anvil International, LLC. (anvilintl.com)

"Access to Safe, Quality Healthcare Environments that Meet California's Diverse and Dynamic Needs"





**OFFICE OF STATEWIDE HEALTH PLANNING AND DEVELOPMENT
FACILITIES DEVELOPMENT DIVISION**

Registered Design Professional Preparing Engineering Recommendations

Company Name: CYS Structural Engineers, Inc.

Name: Dieter T. Siebald California License Number: S4346

Mailing Address: 2495 Natomas Park Drive, Suite # 650, Sacramento, CA 95833

Telephone: (916) 920-2020 Email: dieters@cyseng.com

OSHPD Special Seismic Certification Preapproval (OSP)

- Special Seismic Certification is preapproved under OSP-
(Separate application for OSP is required)
- Special Seismic Certification is not preapproved

Certification Method(s)

- Testing in accordance with: ICC-ES AC156 FM 1950-10
- Other* (Please Specify): _____

*Use of criteria other than those adopted by the California Building Standards Code, 2016 (CBSC 2016) for component supports and attachments are not permitted. For distribution system, interior partition wall, and suspended ceiling seismic bracings, test criteria other than those adopted in the CBSC 2016 may be used when approved by OSHPD prior to testing.

- Analysis
- Experience Data
- Combination of Testing, Analysis, and/or Experience Data (Please Specify): Testing per FM 1950-10 and Analysis per pertinent chapters of 2013 CBC.

List of Attachments Supporting the Manufacturer's Certification

- Test Report Drawings Calculations Manufacturer's Catalog
- Other(s) (Please Specify): (3) FM Approval Reports, (3) FM Certificates of Compliance, OPA-2804-10, FM Approval Standard 1950 March 2010,

OFFICE USE ONLY – OSHPD APPROVAL VALID FOR CBC 2016 & ALL PRE-2016 CODE BASED PROJECTS

Signature:  Date: 09/26/2016

Print Name: Jeffrey Kikumoto

Title: SSE

Condition of Approval (if applicable): _____

"Access to Safe, Quality Healthcare Environments that Meet California's Diverse and Dynamic Needs"



SEISMIC SWAY BRACING FOR FIRE PROTECTION SYSTEMS

TABLE OF CONTENTS
OPM-0351-13

PAGE

1. GENERAL INFORMATION	2
1.1. PRE-APPROVAL GUIDE SCOPE & ABBREVIATIONS	
1.2. BRACE SPACING GUIDELINES PER NFPA 13 - 2013	
1.3. RESPONSIBILITIES OF THE CALIFORNIA REGISTERED DESIGN PROFESSIONAL (CRDP)	
1.4. USING ANVIL INTERNATIONAL'S PRE-APPROVAL GUIDE	
1.5. SEISMIC DESIGN CRITERIA	
1.6. ALLOWABLE CAPACITIES OF SEISMIC BRACE COMPONENTS	
1.7. CERTIFICATES OF COMPLIANCE	
2. ANCHORAGES TO CONCRETE STRUCTURE	19
2.1. EXPANSION ANCHORS	
2.2. SUPPORTS & ATTACHMENTS	
3. ANCHORAGES TO WOOD STRUCTURE	26
3.1. SUPPORTS & ATTACHMENTS	
3.2. MAXIMUM ALLOWABLE LOADS	
3.3. MATERIAL SPECIFICATIONS	
4. ANCHORAGES TO STEEL STRUCTURE	28
4.1. FIGURE 771 - SWAY BRACE SWIVEL ATTACHMENT	
4.2. FIGURE 772 - ADJUSTABLE STEEL BEAM ATTACHMENT	
4.3. FIGURE 778 - BAR JOIST BEAM ATTACHMENT	
5. SEISMIC PIPE CLAMPS	39
5.1. FIGURE 770 - Q BRACE CLAMP	
5.2. FIGURE 775 - LATERAL/LONGITUDINAL BRACE CLAMP	
5.3. FIGURE 776 - BRACE CLAMP	
6. MATERIAL SPECIFICATIONS	49
6.1. FIGURE 770 - Q BRACE CLAMP	
6.2. FIGURE 771 - SWAY BRACE SWIVEL ATTACHMENT	
6.3. FIGURE 772 - ADJUSTABLE STEEL BEAM ATTACHMENT	
6.4. FIGURE 775 - LATERAL/LONGITUDINAL BRACE CLAMP	
6.5. FIGURE 776 - BRACE CLAMP	
6.6. FIGURE 778 - BAR JOIST BEAM ATTACHMENT	
7. RISER FOUR-WAY SEISMIC BRACES	52
7.1. FIGURE 770 - Q BRACE CLAMP	
7.2. FIGURE 775 - LATERAL BRACE CLAMP	
7.3. FIGURE 776 - BRACE CLAMP	
8. TYPICAL SWAY BRACE DESIGN PROCEDURE	55

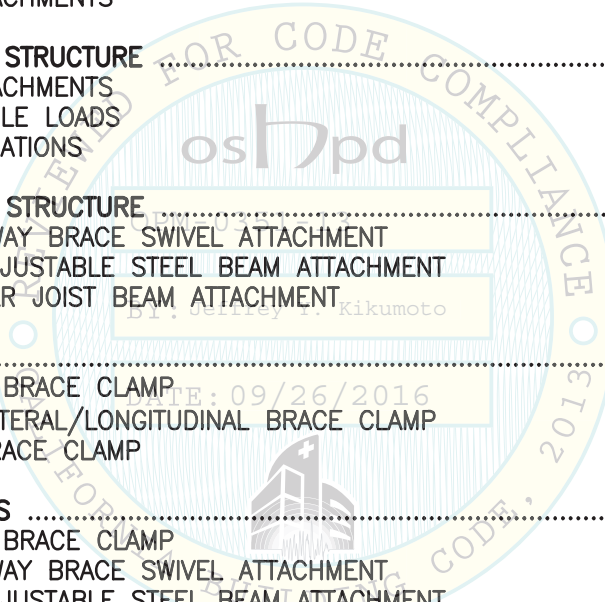

SHEET TITLE: TABLE OF CONTENTS



CYS STRUCTURAL ENGINEERS, INC.

2495 NATOMAS PARK DRIVE, SUITE 650
SACRAMENTO, CA 95833

TEL (916) 920-2020
www.cyseng.com

Job No:	14090
Date:	09-22-2016
Page:	1 of 60

L:\Jobs\14090 Anvil - Fire Sprinkler System OPM-0351-13\ACAD\STRU\S1.dwg Time:Sep22,2016-02:14pm Login:camachom DimScale:1 LTScale:4

SEISMIC SWAY BRACING FOR FIRE PROTECTION SYSTEMS

1. GENERAL INFORMATION:

1.1. PRE-APPROVAL GUIDE SCOPE & ABBREVIATIONS

- 1.1.1. THIS OSHPD PRE-APPROVAL OF MANUFACTURER'S CERTIFICATION (OPM) IS BASED ON THE 2013 CALIFORNIA BUILDING CODE (CBC 2013). THE DEMAND (DESIGN FORCES) FOR USE W/ THIS OPM SHALL BE BASED ON THE CBC 2013.
- 1.1.2. THE PURPOSE OF THIS PRE-APPROVAL MANUAL IS FOR THE DESIGN OF SUPPORTS & ATTACHMENTS OF THE SEISMIC SWAY BRCG OF INTERIOR PIPING FOR FIRE SPRINKLER SYSTEMS SUBJECT TO SEISMIC LOADS.
- 1.1.3. INTERMEDIATE HANGERS & RESTRAINTS FOR OTHER LOADS (I.E. THERMAL LOADS, WATER HAMMER, PRESSURE, OR WATER JET LOADS) ARE BY OTHERS & ARE NOT ADDRESSED IN THIS OPM. FURTHERMORE, DOES NOT ADDRESS COMPONENTS THAT CROSS SEISMIC SEPARATIONS, NOR DOES IT ADDRESS COMPONENTS (OTHER THAN PIPE RISERS) ATTACHED TO PORTIONS OF THE STRUCTURE OR EQUIPMENT THAT WILL EXPERIENCE RELATIVE SEISMIC DISPLACEMENT.
- 1.1.4. THIS PRE-APPROVAL IS INTENDED FOR PIPING SYSTEMS W/ THE PIPE COMPONENT SIZES LISTED IN TABLE 1.1.1 & TABLE 1.1.2.

SERVICE PIPE SCHED	NOMINAL PIPE SIZE (NPS)										
	1	1¼	1½	2	2½	3	3½	4	5	6	-
LIGHTWALL (LW)	1	1¼	1½	2	2½	3	3½	4	5	6	-
10	1	1¼	1½	2	2½	3	3½	4	5	6	8 ¹
40	1	1¼	1½	2	2½	3	3½	4	5	6	8

TABLE 1.1.1 – FIRE SPRINKLER SERVICE PIPE
¹ WALL THK IS 0.188". SEE SECTION 1.7.5.

BRACE PIPE SCHED	MATERIAL GRADE	NOMINAL PIPE SIZE (NPS)
40	ASTM A-53 GR A OR B	1 ¼

TABLE 1.1.2 – BRACE PIPE

- 1.1.5. THE SEISMIC SWAY BRCG SYSTEM SHALL BE ATTACHED TO CONC, STL, OR WOOD SUBSTRATES SUITABLE FOR SUPPORT OF THE REQ LOAD. FOR ATTACHMENT TO THE UNDERSIDE OF CONC FLRS OR A ROOF W/ OR WITHOUT MTL DECK, TO THE FACE OF CONC WALLS, OR TO THE UNDERSIDE OF CONC BMS, SEE SECTION 2. FOR ATTACHMENT TO WOOD BMS, SEE SECTION 3. FOR ATTACHMENT TO WF STL BMS & BAR JOISTS, SEE SECTIONS 4.2 & 4.3.

- 1.1.6. THIS OPM IS INTENDED FOR THE DESIGN OF SUPPORTS & ATTACHMENTS OF SEISMIC SWAY BRCG FOR FIRE PROTECTION SYSTEMS LOCATED IN THE INTERIOR OF A BLDG.

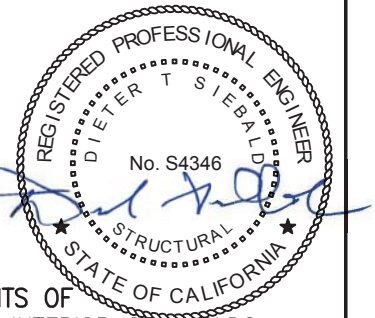

SHEET TITLE: GENERAL INFORMATION
 PRE-APPROVAL GUIDE SCOPE & ABBREVIATIONS



CYS STRUCTURAL ENGINEERS, INC.

2495 NATOMAS PARK DRIVE, SUITE 650
 SACRAMENTO, CA 95833

TEL (916) 920-2020
 www.cyseng.com

Job No:	14090
Date:	09-22-2016
Page:	2 of 60

L:\Jobs\14090 Anvil - Fire Sprinkler System OPM-0351-13\ACAD\STRU\S1.dwg Time:Sep22,2016-02:15pm Login:camachom Dimscale:1 L1Scale:4

SEISMIC SWAY BRACING FOR FIRE PROTECTION SYSTEMS

1.1. PRE-APPROVAL GUIDE SCOPE & ABBREVIATIONS (CONTINUED)

1.1.7. ABBREVIATIONS:

@	AT		
AB	ANCHOR BOLT	FM	FM APPROVALS (AKA FACTORY MUTUAL)
ABV	ABOVE	Fp	HORIZONTAL SEISMIC FORCE PER
ACI	AMERICAN CONCRETE INSTITUTE		ASCE 7-10 SEISMIC FORCE
ADDNL	ADDITIONAL		REQUIREMENTS
AISC	AMERICAN INSTITUTE OF STEEL	Fpv	VERTICAL SEISMIC FORCE PER
	CONSTRUCTION		ASCE 7-10 SEISMIC FORCE
ASD	ALLOWABLE STRENGTH DESIGN		REQUIREMENTS
ALT	ALTERNATE	Fpw	HORIZONTAL SEISMIC FORCE PER
ASCE	AMERICAN SOCIETY OF CIVIL ENGINEERS		NFPA 13 2013 EDITION SEISMIC FORCE
ASME	AMERICAN SOCIETY OF MECHANICAL		REQUIREMENTS
	ENGINEERS	Fvnet	VERTICAL FORCE RESULTANT FROM Fpw
ASD	ALLOWABLE STRENGTH DESIGN	Fy	SPECIFIED MINIMUM YIELD STRESS OF
ASTM	AMERICAN SOCIETY FOR TESTING &		STEEL, KSI
	MATERIALS	GA	GAUGE
BM	BEAM	GR	GRADE
BLDG	BUILDING	HORIZ	HORIZONTAL
BLKG	BLOCKING	HT	HEIGHT
BLW	BELOW	ICC	INTERNATIONAL CODE COUNCIL
BOTT	BOTTOM	IN ("")	INCH
BRCC	BRACING	INFO	INFORMATION
CAC	CALIFORNIA ADMINISTRATIVE CODE	IOR	INSPECTOR OF RECORD
CBC	CALIFORNIA BUILDING CODE	KSI	KIPS PER SQUARE INCH
CG	CENTER OF GRAVITY : Jeffrey Y. Kikumoto	L	LENGTH
CLSE	CALIFORNIA LICENSED STRUCTURAL	LBS	POUNDS
	ENGINEER	LONG	LONGITUDINAL
☒	CENTERLINE	LRFD	LOAD & RESISTANCE FACTOR DESIGN
CONC	CONCRETE	LW	LIGHTWALL
CONT	CONTINUOUS	LWC	LIGHTWEIGHT CONCRETE
CRDP	CALIFORNIA REGISTERED DESIGN	MAX	MAXIMUM
	PROFESSIONAL	MFR	MANUFACTURER
DEG	DEGREE	MIN	MINIMUM
DTL(S)	DETAIL(S)	MTL	METAL
DIA (∅)	DIAMETER		
DIM(S)	DIMENSION(S)		
(E)	EXISTING CONDITION		
EA	EACH		
ELEV	ELEVATION		
EQ	EQUAL		
f'c	SPECIFIED COMPRESSIVE STRENGTH		
	OF CONCRETE		
FLR	FLOOR		
FT (')	FOOT/FEET		

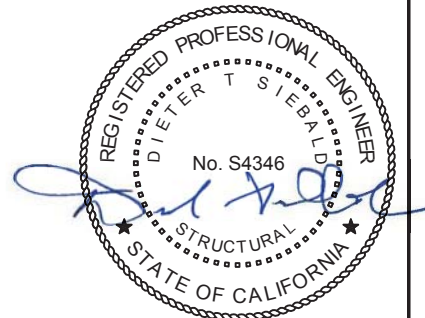
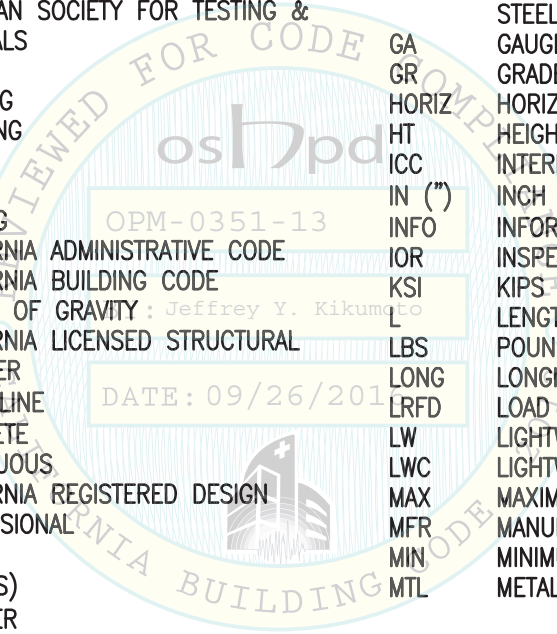

SHEET TITLE: GENERAL INFORMATION
PRE-APPROVAL GUIDE SCOPE & ABBREVIATIONS

 CYS STRUCTURAL ENGINEERS, INC. 2495 NATOMAS PARK DRIVE, SUITE 650 SACRAMENTO, CA 95833	TEL (916) 920-2020 www.cyseng.com	Job No: 14090 Date: 09-22-2016 Page: 3 of 60
---	--------------------------------------	--

L:\Jobs\14090 Anvil - Fire Sprinkler System OPM-0351-13\ACAD\STRU\S1.dwg Time:Sep22,2016-02:15pm Login:camachom DimScale:1 LScale:4

SEISMIC SWAY BRACING FOR FIRE PROTECTION SYSTEMS

1.1. PRE-APPROVAL GUIDE SCOPE & ABBREVIATIONS (CONTINUED)

1.1.7. ABBREVIATIONS:

N/A	NOT APPLICABLE	VERT	VERTICAL
NDS	NATIONAL DESIGN SPECIFICATION FOR WOOD CONSTRUCTION	Vn	NOMINAL SHEAR STRENGTH PER ACI APPENDIX D
NFPA	NATIONAL FIRE PROTECTION ASSOCIATION	VSB	VERTICAL SEISMIC BRACE
Nn	NOMINAL STRENGTH IN TENSION PER ACI 318 APPENDIX D	Vua	FACTORED SHEAR FORCE APPLIED TO A SINGLE ANCHOR OR GROUP OF ANCHORS PER ACI 318 APPENDIX D
NPS	NORMAL PIPE SIZE	W/	WITH
Nua	FACTORED TENSILE FORCE APPLIED TO ANCHOR OR INDIVIDUAL ANCHOR IN A GROUP OF ANCHORS PER ACI 318 APPENDIX D	WF	WIDE FLANGE
NWC	NORMAL WEIGHT CONCRETE	Wp	WEIGHT OF WATER-FILLED PIPE x 1.15 AS PER NFPA 13 SECTION 9.3.5.9.2
OPM	OSHPD PRE-APPROVAL OF MANUFACTURER'S CERTIFICATION	WT	WEIGHT
OSHPD	OFFICE OF STATEWIDE HEALTH PLANNING & DEVELOPMENT		
PERP	PERPENDICULAR		
PG	PAGE		
PSI	POUNDS PER SQUARE INCH		
r	RADIUS OF GYRATION		
REINF	REINFORCING		
REQ	REQUIRED		
SCHED	SCHEDULE		
SEOR	STRUCTURAL ENGINEER OF RECORD		
SIM	SIMILAR		
SLWC	SAND LIGHTWEIGHT CONCRETE		
SPECS	SPECIFICATIONS		
SPCG	SPACING		
STD	STANDARD		
STL	STEEL		
STRUC	STRUCTURAL		
T	ANCHORAGE TENSION REACTION DUE TO SEISMIC FORCE		
T/C	TENSION OR COMPRESSION		
THK	THICK/THICKNESS		
THRD	THREAD/THREADED		
TRANS	TRANSVERSE		
TYP	TYPICAL		
UNO	UNLESS NOTED OTHERWISE		
V	ANCHORAGE SHEAR REACTION DUE TO SEISMIC FORCES		
UL	UNDERWRITERS' LABORATORIES		
USD	ULTIMATE STRENGTH DESIGN		

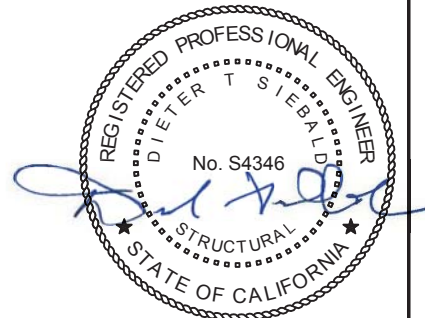
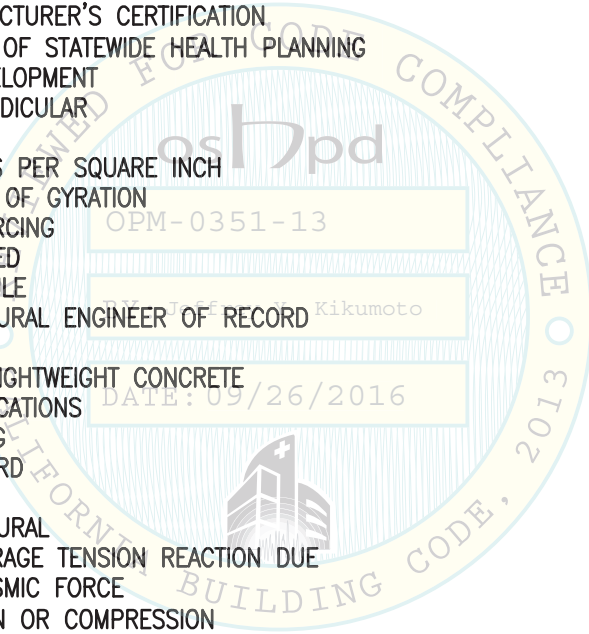

SHEET TITLE: GENERAL INFORMATION
PRE-APPROVAL GUIDE SCOPE & ABBREVIATIONS



CYS STRUCTURAL ENGINEERS, INC.

2495 NATOMAS PARK DRIVE, SUITE 650
SACRAMENTO, CA 95833

TEL (916) 920-2020
www.cyseng.com

Job No:	14090
Date:	09-22-2016
Page:	4 of 60

L:\Jobs\14090 Anvil - Fire Sprinkler System OPM-0351-13\ACAD\STRU\S1.dwg Time:Sep22,2016 -02:15pm Login:camachom DimScale:1 LTScale:4

SEISMIC SWAY BRACING FOR FIRE PROTECTION SYSTEMS

1.2. BRACE SPACING GUIDELINES PER NFPA 13 – 2013

- 1.2.1. A RUN OF PIPE IS CONSIDERED A CONT STRAIGHT LENGTH IF THE MAX OFFSET IS LESS THAN 24". IF THE OFFSET IS 24" OR GREATER, EA CONT STRAIGHT LENGTH SHALL BE TREATED AS AN INDEPENDENT RUN & BRACED APPROPRIATELY. SEE FIGURE 1.2.1.
- 1.2.2. TRANS SEISMIC BRCC
- 1.2.2.1. TRANS BRCC MAY ALSO BE REFERRED TO AS LATERAL BRCC.
- 1.2.2.2. TRANS BRCC LIMITS SEISMIC MOVEMENT PERP TO THE SERVICE PIPE RUN IN THE HORIZ DIRECTION.
- 1.2.2.3. TRANS BRCC SHALL BE PROVIDED ON ALL FEED & CROSS MAINS REGARDLESS OF SERVICE PIPE SIZE & ALL OTHER PIPING (E.G. BRANCH LINES, ETC.) W/ A SERVICE PIPE DIA OF 2½" & LARGER. THE LAST LENGTH OF PIPE AT THE END OF A FEED OR CROSS MAIN SHALL BE PROVIDED W/ A TRANS BRACE.
- 1.2.2.4. TRANS BRCC MAX SPCG FOR PIPING CONSTRUCTED OF DUCTILE MATERIALS (E.G. STL) SHALL BE 40 FT (2½" DIA PIPING & LARGER); 30 FT MAX SPAN (PIPING SMALLER THAN 2½" DIA), SEE FIGURE 1.2.2. NOTE THAT THE FLEXURAL CAPACITY OF THE SERVICE PIPE OR THE BRACE ASSEMBLY OR THE MAX CALCULATED LOAD IN THE NFPA ZONE OF INFLUENCE MAY REDUCE THE SPCG OF THE TRANS BRCC. REFER TO SECTION 8, STEP 4.
- 1.2.2.5. A TRANS BRACE PLACED WITHIN 24" OF A 90 DEG CHANGE OF DIRECTION OF THE SERVICE PIPE (E.G. ELBOW, TEE, CROSS, ETC.) MAY ACT AS A LONG BRACE; SEE FIGURE 1.2.2.
- 1.2.2.6. THE MIN BRACE REQUIREMENTS FOR SERVICE PIPE RUNS EXCEEDING 5 FT IS A TRANS BRACE AT EA END OF THE RUN & A LONG BRACE AT ONE OF THOSE TWO POSITIONS; SEE FIGURE 1.2.3.
- 1.2.2.7. BRCC INSTALLED ON SMALLER PIPING SHALL NOT BE USED TO BRACE LARGER DIA PIPING.
- 1.2.2.8. EXCEPTIONS: ALL PIPING SUSPENDED BY INDIVIDUAL HANGER RODS 6" OR LESS IN LENGTH FROM THE TOP OF THE PIPE TO THE BOTT OF THE SUPPORT STRUCTURE WHERE HANGER IS CONNECTED. ALL OF THE HANGERS OF A RUN MUST COMPLY W/ THE 6-INCH RULE OR BRCC IS REQ.

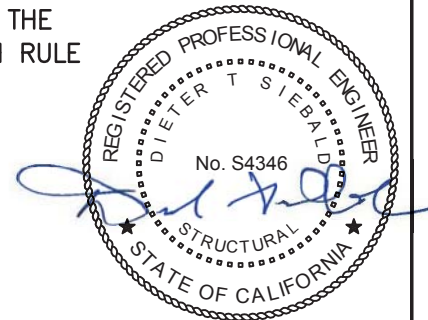

SHEET TITLE: GENERAL INFORMATION
BRACE SPACING GUIDELINES PER NFPA 13 - 2013



CYS STRUCTURAL ENGINEERS, INC.

2495 NATOMAS PARK DRIVE, SUITE 650
SACRAMENTO, CA 95833

TEL (916) 920-2020
www.cyseng.com

Job No:	14090
Date:	09-22-2016
Page:	5 of 60

L:\Jobs\14090 Anvil - Fire Sprinkler System OPM-0351-13\ACAD\STRU\S1.dwg Time:Sep22,2016-02:15pm Login:camachom Dimstyle:1 LTScale:4

SEISMIC SWAY BRACING FOR FIRE PROTECTION SYSTEMS

1.2. BRACE SPACING GUIDELINES PER NFPA 13 – 2013

1.2.3. LONG SEISMIC BRCG

1.2.3.1. LONG BRCG LIMITS SEISMIC MOVEMENT PARALLEL TO THE SERVICE PIPE RUN.

1.2.3.2. LONG BRCG MAX SPCG FOR PIPING CONSTRUCTED OF DUCTILE MATERIALS (E.G. STL) SHALL BE 80 FT (2½" DIA PIPING & LARGER); 60 FT MAX SPAN (PIPING SMALLER THAN 2½" DIA); SEE FIGURE 1.2.2.

1.2.3.3. EA PIPE RUN MUST HAVE AT LEAST ONE LONG BRACE. ADDNL LONG BRACES ARE REQ WHEN THE MAX LONG SPCG IS EXCEEDED; SEE FIGURES 1.2.1, 1.2.2, & 1.2.3.

1.2.4. VERT SEISMIC BRCG

1.2.4.1. VERT BRCG LIMITS SEISMIC MOVEMENT PERP TO THE SERVICE PIPE IN THE VERT DIRECTION.

1.2.4.2. VERT BRCG SHALL BE PLACED NO MORE THAN 6" FROM EA TRANS & LONG SEISMIC BRACE. SEE FIGURES 1.2.1 THRU 1.2.4.

1.2.4.3. WHEN A TRANS & LONG SEISMIC BRACE OCCUR AT THE SAME LOCATION, A VERT SEISMIC BRACE SHALL BE PLACED BETWEEN THE TRANS & LONG SEISMIC BRACES.

1.2.5. VERT OFFSETS/RISERS

1.2.5.1. A FOUR-WAY BRACE SHALL BE PROVIDED WITHIN 24" OF THE TOP OF A VERT OFFSET OR RISER EXCEEDING 3 FT. SEE FIGURE 1.2.4.

1.2.5.2. FOUR-WAY BRCG MAX SPCG FOR PIPE CONSTRUCTED OF DUCTILE MATERIALS (E.G. STL) SHALL BE 25 FT. SEE FIGURE 1.2.4.

1.2.6. WHEN CALCULATING HORIZ & VERT SEISMIC LOAD REQUIREMENTS, USE TABLE 1.2.1 TO CALCULATE THE WT OF WATER-FILLED PIPE.

1.2.7. FOR SWAY BRACE PIPE AXIAL CAPACITY & ALLOWABLE PIPE LENGTH, USE TABLE 1.2.2 & TABLE 1.2.3

1.2.8. SERVICE PIPES THAT CROSS A BLDG SEPARATION OR SEISMIC JOINT MUST BE DESIGNED TO ACCOMMODATE THE SEISMIC RELATIVE DISPLACEMENT AS PER ASCE 7-10, SECTION 13.3.2 OR AS SPECIFIED BY THE SEOR ON THE OSHPD APPROVED CONSTRUCTION DOCUMENTS.



SHEET TITLE: GENERAL INFORMATION
BRACE SPACING GUIDELINES PER NFPA 13 - 2013



CYS STRUCTURAL ENGINEERS, INC.

2495 NATOMAS PARK DRIVE, SUITE 650
SACRAMENTO, CA 95833

TEL (916) 920-2020
www.cyseng.com

Job No:	14090
Date:	09-22-2016
Page:	6 of 60

L:\Jobs\14090 Anvil - Fire Sprinkler System OPM-0351-13\ACAD\STRU\S1.dwg Time:Sep22,2016--02:15pm Login:camachom DimScale:1 LScale:4

SEISMIC SWAY BRACING FOR FIRE PROTECTION SYSTEMS

1.2. BRACE SPACING GUIDELINES PER NFPA 13 - 2013 (CONTINUED)

A PIPE HANGER IS NOT A VERT SEISMIC BRACE. PIPE HANGERS ARE NOT PART OF THIS OPM & ARE NOT SHOWN IN THIS OPM

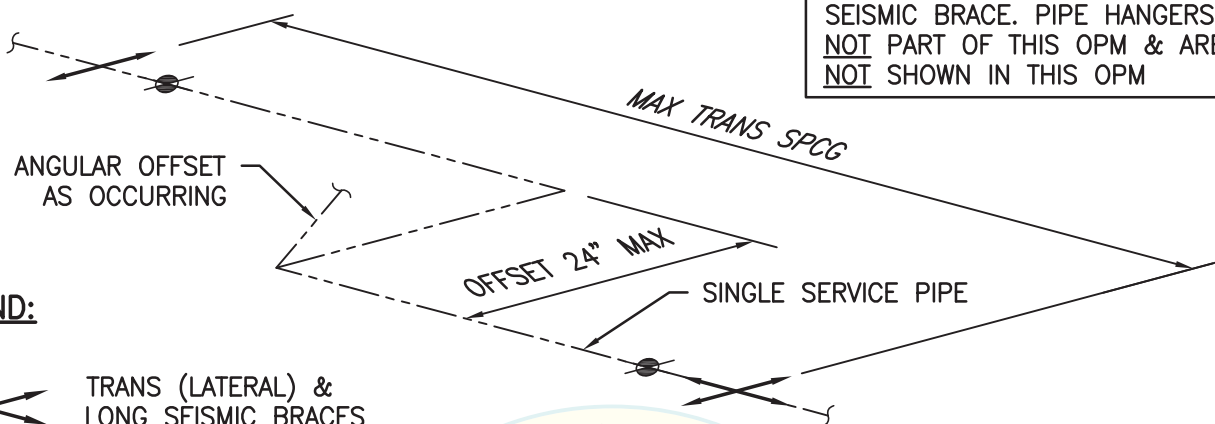

LEGEND:

- TRANS (LATERAL) & LONG SEISMIC BRACES
- TRANS (LATERAL) SEISMIC BRACE

A VERT SEISMIC BRACE - MUST BE WITHIN 6" OF EA TRANS & EA LONG BRACE

FIGURE 1.2.1 - BRCG FOR PIPING W/ A 24" MAX OFFSET

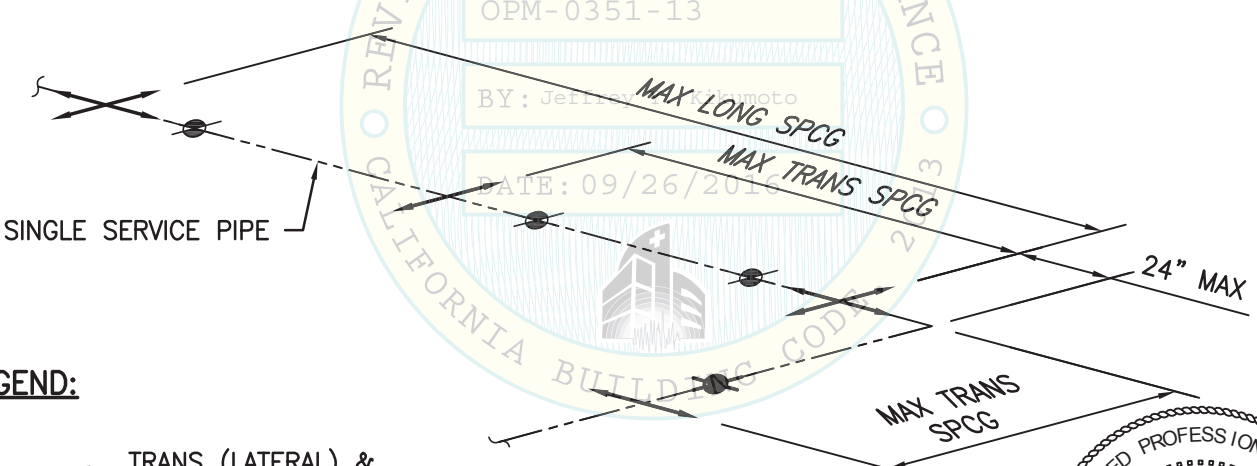

LEGEND:

- TRANS (LATERAL) & LONG SEISMIC BRACES
- TRANS (LATERAL) SEISMIC BRACE

A VERT SEISMIC BRACE - MUST BE WITHIN 6" OF EA TRANS & EA LONG BRACE

FIGURE 1.2.2 - BRCG FOR PIPING W/ MAX LONG & TRANS SPCG



SHEET TITLE: GENERAL INFORMATION
BRACE SPACING GUIDELINES PER NFPA 13 - 2013

<p>CYS STRUCTURAL ENGINEERS, INC. 2495 NATOMAS PARK DRIVE, SUITE 650 SACRAMENTO, CA 95833</p>	TEL (916) 920-2020 www.cyseng.com	Job No: 14090 Date: 09-22-2016 Page: 7 of 60
--	--------------------------------------	--

L:\Jobs\14090 Anvil - Fire Sprinkler System OPM-0351-13\ACAD\STRU\S1.dwg Time: Sep 22, 2016 - 02:15pm Login: camachom DimScale: 1 LTScale: 4

SEISMIC SWAY BRACING FOR FIRE PROTECTION SYSTEMS

1.2. BRACE SPACING GUIDELINES PER NFPA 13 – 2013 (CONTINUED)

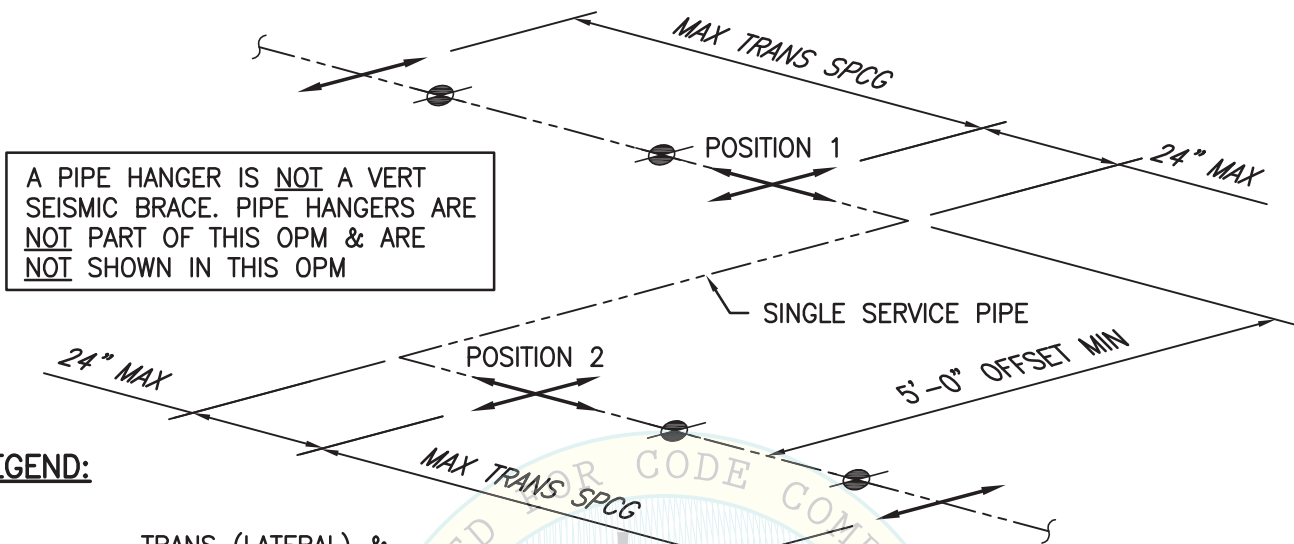

A PIPE HANGER IS NOT A VERT SEISMIC BRACE. PIPE HANGERS ARE NOT PART OF THIS OPM & ARE NOT SHOWN IN THIS OPM

LEGEND:

- TRANS (LATERAL) & LONG SEISMIC BRACES
- TRANS (LATERAL) SEISMIC BRACE

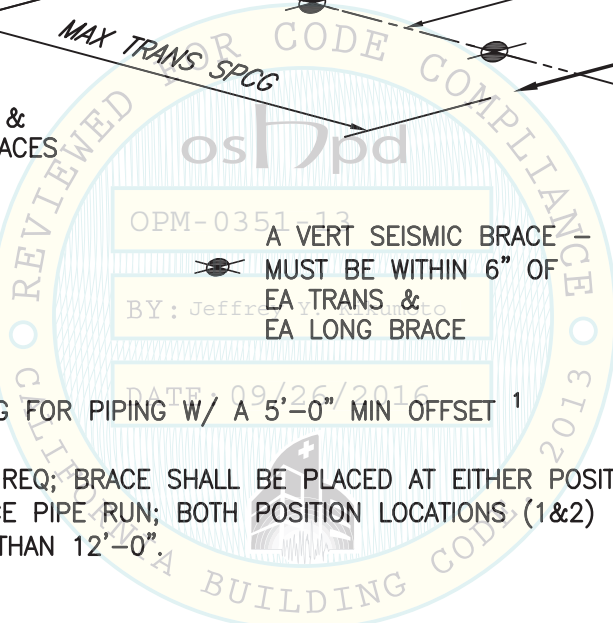

A VERT SEISMIC BRACE MUST BE WITHIN 6" OF EA TRANS & EA LONG BRACE

FIGURE 1.2.3 – MIN REQ BRCG FOR PIPING W/ A 5'-0" MIN OFFSET ¹

¹ AT LEAST ONE LONG BRACE REQ; BRACE SHALL BE PLACED AT EITHER POSITION 1 OR POSITION 2 UP TO 12'-0" LONG SERVICE PIPE RUN; BOTH POSITION LOCATIONS (1&2) PLUS OWN INDIVIDUAL LATERAL BRCG IF GREATER THAN 12'-0"



SHEET TITLE: GENERAL INFORMATION
BRACE SPACING GUIDELINES PER NFPA 13 - 2013

<p>CYS STRUCTURAL ENGINEERS, INC. 2495 NATOMAS PARK DRIVE, SUITE 650 SACRAMENTO, CA 95833</p>	TEL (916) 920-2020 www.cyseng.com	Job No: 14090 Date: 09-22-2016 Page: 8 of 60
--	--------------------------------------	--

L:\Jobs\14090 Anvil - Fire Sprinkler System OPM-0351-13\ACAD\STRU\S1.dwg Time: Sep 22, 2016 - 02:15pm Login: camachom DimScale: 1 LScale: 4

SEISMIC SWAY BRACING FOR FIRE PROTECTION SYSTEMS

1.2. BRACE SPACING GUIDELINES PER NFPA 13 – 2013 (CONTINUED)

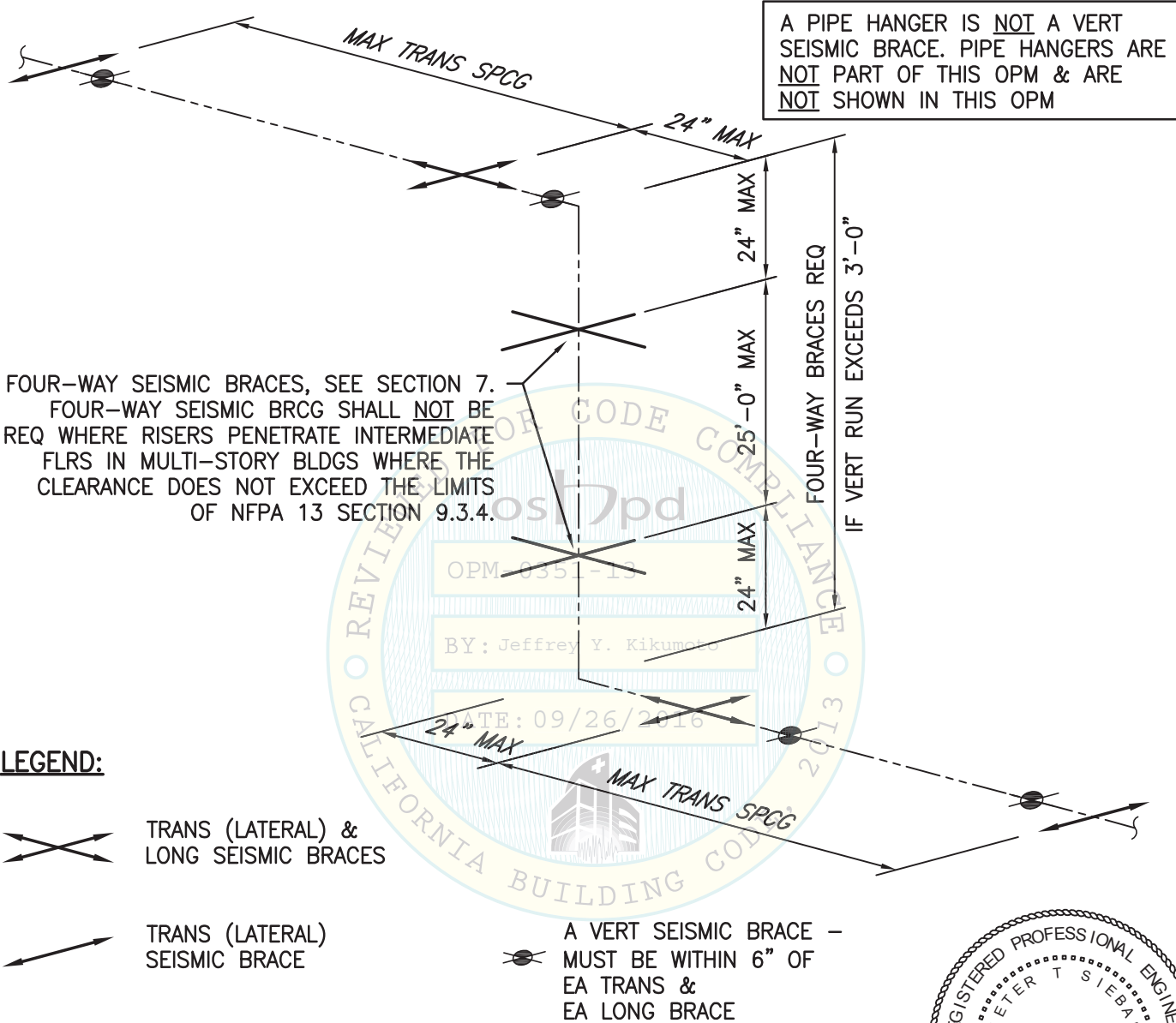

FIGURE 1.2.4 – BRCG FOR PIPING W/ A VERT RISER



SHEET TITLE: GENERAL INFORMATION
BRACE SPACING GUIDELINES PER NFPA 13 - 2013

<p>CYS STRUCTURAL ENGINEERS, INC. 2495 NATOMAS PARK DRIVE, SUITE 650 SACRAMENTO, CA 95833</p>	TEL (916) 920-2020 www.cyseng.com	Job No: 14090 Date: 09-22-2016 Page: 9 of 60
--	--------------------------------------	--

L:\Jobs\14090 Anvil - Fire Sprinkler System OPM-0351-13\ACAD\STRU\S1.dwg Time:Sep22,2016-02:15pm Login:camachom DimScale:1 LScale:4

SEISMIC SWAY BRACING FOR FIRE PROTECTION SYSTEMS

SERVICE PIPE SIZE (NPS)	WT OF SCHED 40 WATER-FILLED PIPE ¹ (LBS/FT)	WT OF SCHED 10 WATER-FILLED PIPE ¹ (LBS/FT)	WT OF SCHED LW WATER-FILLED PIPE ⁴ (LBS/FT)
1	2.05	1.81	1.35
1¼	2.93	2.52	1.91
1½	3.61	3.04	2.59
2	5.13	4.22	3.63
2½	7.89	5.89	5.32
3	10.82	7.94	6.81
3½	13.48	9.78	N/A
4	16.40	11.78	10.68
5	23.47	17.30	N/A
6	31.69	23.03	21.92
8	47.70 ²	40.08 ³	N/A

TABLE 1.2.1 – WT OF WATER-FILLED SERVICE PIPE

¹ PIPING WTS PER NFPA 13, TABLE A.9.3.5.9 FOR DETERMINING VERT & HORIZ LOADS.

² SCHED 30.

³ WALL THK IS 0.188". SEE SECTION 1.7.5. ⁴ PIPING WTS PER TABLE 8.5.3.

BRACE PIPE ¹ (NPS)	PIPE SCHED	NOMINAL OUTSIDE DIA (INCH)	NOMINAL WALL THK (INCH)	DESIGN WALL THK (INCH)	CROSS SECTIONAL AREA (A) (IN ²)	D/t	RADIUS OF GYRATION (r) (IN)
1	40	1.315	0.133	0.124	0.463	10.6	0.423
1¼	40	1.660	0.140	0.130	0.626	12.8	0.543

TABLE 1.2.2 – BRACE PIPE DIMS & PROPERTIES

¹ BRACE PIPE DIMS PER AISC STEEL CONSTRUCTION MANUAL, 14TH EDITION, TABLE 1-14.

BRACE PIPE (NPS)	BRACE PIPE LENGTH	SLENDERNESS KL/r	ECCENTRICITY e (IN)	AXIAL CAPACITY ASTM A-53 GR A ¹ (LBS)	AXIAL CAPACITY ASTM A-53 GR B ¹ (LBS)
1	3'-6"	100	0.524	3015	3377
1	7'-0"	200	0.524	1406	1448
1	10'-6"	300	0.524	706	716
1¼	4'-6"	100	0.690	4009	4491
1¼	9'-0"	200	0.690	1875	1933
1¼	13'-6"	300	0.690	943	958

TABLE 1.2.3 – BRACE PIPE MEMBER LENGTH & AXIAL CAPACITY – COMBINED FLEXURE & AXIAL LOAD

¹ AXIAL CAPACITY CALCULATED W/ DIMS FROM TABLE 1.2.2. & PER AISC STEEL CONSTRUCTION MANUAL, 14TH EDITION, PART 2. LOADS CONTROLLED BY CRITICAL COLUMN LOAD. K=1; MODULUS OF ELASTICITY TAKEN AS 29,000,000 PSI; ASTM A53 GR A, Fy=30 KSI; e=D/2-t nom ASTM A53 GR B, Fy=35 KSI. AXIAL CAPACITY SHOWN IS ASD. MULTIPLY VALUE BY 1.5 TO CONVERT TO LOAD IN LRFD.



SHEET TITLE: GENERAL INFORMATION

BRACE SPACING GUIDELINES PER NFPA 13 - 2013

 CYS STRUCTURAL ENGINEERS, INC. 2495 NATOMAS PARK DRIVE, SUITE 650 SACRAMENTO, CA 95833	TEL (916) 920-2020 www.cyseng.com	Job No: 14090 Date: 09-22-2016 Page: 10 of 60
---	--------------------------------------	---

L:\Jobs\14090 Anvil - Fire Sprinkler System OPM-0351-13\ACAD\STRU\S1.dwg Time:Sep22,2016 -02:15pm Login:camachom DimScale:1 LTScale:4

SEISMIC SWAY BRACING FOR FIRE PROTECTION SYSTEMS

1.3. RESPONSIBILITIES OF THE CALIFORNIA REGISTERED DESIGN PROFESSIONAL (CRDP)

- 1.3.1. ANVIL INTERNATIONAL'S DESIGN GUIDELINES FOR SEISMIC BRCG OF INTERIOR FIRE SPRINKLER SYSTEMS ARE IN COMPLIANCE W/ THE FOLLOWING:
 - 1.3.1.1. 2013 CBC, TITLE 24, PART 2, VOLUME 2
 - 1.3.1.2. ASCE 7-10 INCLUDING SUPPLEMENTS #1 & #2
 - 1.3.1.3. NFPA 13, 2013 EDITION
 - 1.3.1.4. ANSI/AWC NDS-2012
 - 1.3.1.5. ACI 318-11

- 1.3.2. IT IS THE RESPONSIBILITY OF THE CRDP DESIGNING THE BRCG SYSTEM, TO VERIFY THAT THE SYSTEM DESIGN IS IN CONFORMANCE W/ THE 2013 CBC INCLUDING SECTION 1616A. MODIFICATIONS TO ASCE 7 SECTION 13 & THE APPLICATIONS & DETAILS SHOWN WITHIN THIS PRE-APPROVAL.

- 1.3.3. THE CRDP MUST SHOW THE OSHPD APPROVED PRE-APPROVAL NUMBER (OPM-0351-13) & THE SUPPORT & BRCG OF ALL INTERIOR SERVICE PIPES ON THE LAYOUT DRAWINGS & PREPARE THEM FOR SUBMITTAL TO THE DISCIPLINE IN RESPONSIBLE CHARGE OF THE PROJECT FOR REVIEW & APPROVAL. THE CRDP MUST STAMP & SIGN THE LAYOUT DRAWINGS.

- 1.3.4. THE CRDP MUST REVIEW SECTION 1.1 TO VERIFY THAT THE SIZES & TYPES OF COMPONENTS & THE SUBSTRATES ON HIS/HER PROJECT ARE INCLUDED IN THIS PRE-APPROVAL PRIOR TO LISTING THE OPM ON THE LAYOUT DRAWINGS AS AN OPTION FOR THE BRCG OF THE DISTRIBUTION SYSTEM. IF THE PROJECT INCLUDES ANY COMPONENTS OR CONNECTIONS TO SUBSTRATES THAT ARE NOT INCLUDED IN THIS PRE-APPROVAL, THEN THEY MUST BE ENGINEERED & DETAILED ON THE LAYOUT DRAWINGS THAT ARE BEING SUBMITTED.

- 1.3.5. THE CRDP MUST REVIEW SECTION 1.2 TO BE FAMILIAR W/ ALL REQUIREMENTS FOR SEISMIC SWAY BRCG.

- 1.3.6. PER SECTION 1.2.4, THE CRDP SHALL ARRANGE & DESIGN THE TRANS, LONG & VERT SEISMIC BRACES SO THAT THERE IS A VERT SEISMIC BRACE NO MORE THAN 6" FROM EA TRANS & EA LONG BRACE MEMBER. PLEASE NOTE THAT A GRAVITY SERVICE PIPE HANGER IS NOT A VERT SEISMIC BRACE.

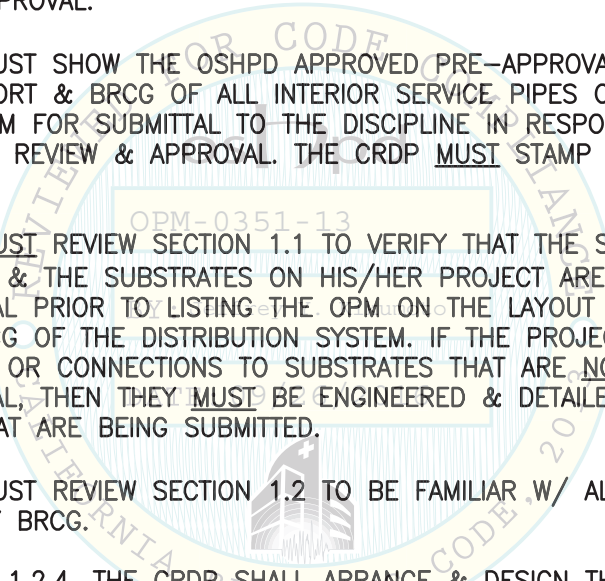

SHEET TITLE: GENERAL INFORMATION
 RESPONSIBILITIES OF THE CALIFORNIA REGISTERED DESIGN PROFESSIONAL

	CYS STRUCTURAL ENGINEERS, INC.	Job No: 14090	
	2495 NATOMAS PARK DRIVE, SUITE 650 SACRAMENTO, CA 95833	TEL (916) 920-2020 www.cyseng.com	Date: 09-22-2016

L:\Jobs\14090 Anvil - Fire Sprinkler System OPM-0351-13\ACAD\STRU\S1.dwg Time:Sep22,2016-02:15pm Login:camachom DimScale:1 LTScale:4

SEISMIC SWAY BRACING FOR FIRE PROTECTION SYSTEMS

1.3. **RESPONSIBILITIES OF THE CALIFORNIA REGISTERED DESIGN PROFESSIONAL (CRDP)**

- 1.3.7. THE CRDP SHALL CHECK THE VERT SEISMIC BRACE ASSEMBLY FOR BOTH TENSION & COMPRESSION LOADS & DETERMINE WHETHER THE VERT SEISMIC BRACE ASSEMBLY OF THE BRG SYSTEM IS ADEQUATE. THE TENSION LOADS ON THE VERT SEISMIC BRACE ASSEMBLY MUST INCLUDE THE MAX TRIBUTARY DEAD LOAD, THE VERT COMPONENTS OF THE TRANS &/OR LONG BRACES, & THE TRIBUTARY VERT SEISMIC LOAD. COMPRESSION LOADS ON THE VERT SEISMIC BRACE ASSEMBLY MUST INCLUDE THE VERT COMPONENTS OF THE TRANS &/OR LONG BRACES, & THE TRIBUTARY VERT SEISMIC LOAD, BUT MUST NOT BE OFFSET BY TRIBUTARY DEAD LOADS UNLESS IT CAN BE VERIFIED THAT THE DEAD LOADS WILL, IN FACT, BE APPLIED TO THE VERT SEISMIC BRACE ASSEMBLY IN QUESTION.
- 1.3.8. THE CRDP SHALL ARRANGE THE ANCHORS TO ENSURE THAT THEY CAN BE INSTALLED IN ACCORDANCE W/ THIS PRE-APPROVAL & THAT THERE ARE NO SLAB EDGES, OPENINGS, OR OTHER ANCHORS NEAR THE ANCHORS TO REDUCE THEIR CAPACITIES. THE CAPACITIES INDICATED IN THIS PRE-APPROVAL ARE BASED ON A MIN DISTANCE TO EDGE OF CONC, AS SHOWN IN TABLE 2.1.1 & APPLICABLE LRFD LOAD COMBINATIONS PER ASCE 7 SECTION 12.4 IN THE ANALYSIS. THE ANCHOR CAPACITIES ARE FOR USE IN THE INTERACTION EQUATION PER ACI 318-11 SECTION D.7.

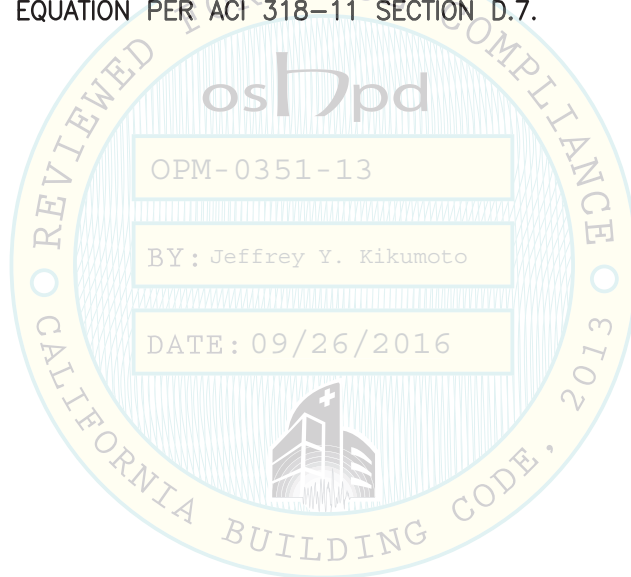

SHEET TITLE: GENERAL INFORMATION
 RESPONSIBILITIES OF THE CALIFORNIA REGISTERED DESIGN PROFESSIONAL

 CYS STRUCTURAL ENGINEERS, INC. 2495 NATOMAS PARK DRIVE, SUITE 650 SACRAMENTO, CA 95833	TEL (916) 920-2020 www.cyseng.com	Job No: 14090 Date: 09-22-2016 Page: 12 of 60

L:\Jobs\14090 Anvil - Fire Sprinkler System OPM-0351-13\ACAD\STRU\S1.dwg Time:Sep22,2016-02:15pm Login:camachom Dimscale:1 LScale:4

SEISMIC SWAY BRACING FOR FIRE PROTECTION SYSTEMS

1.4. USING ANVIL INTERNATIONAL'S PRE-APPROVAL GUIDE

IT IS THE RESPONSIBILITY OF THE USER OF THIS MANUAL TO BE FAMILIAR W/ ALL REQUIREMENTS FOR SEISMIC SWAY BRCG INTENDED FOR USE W/ FIRE SPRINKLER PIPING SYSTEMS & SHALL BE PROFICIENT IN DETERMINING & APPLYING PIPE LOADS FOR THEIR APPLICATION.

PER NFPA 13, THE USER SHALL DETERMINE THE SPCG & LAYOUT FOR THE REQ BRCG. THE USER SHALL DETERMINE THE MAX HORIZ, VERT, & AXIAL FORCE COMPONENT OF THE EARTHQUAKE DEMAND LOADS ACCORDING TO NFPA 13 – SECTION 9.3. USER'S CALCULATION MUST TAKE INTO CONSIDERATION THE INCREASES IN LOADS CAUSED BY CONSTRUCTION TOLERANCES. CONSTRUCTION TOLERANCES FOR ANGLES OF ALL SEISMIC BRACES FROM VERT OR HORIZ SHALL BE LIMITED TO ±5.0 DEGREES. CONSTRUCTION TOLERANCES FOR VERT SEISMIC BRACES FROM VERT SHALL BE LIMITED TO ±5.0 DEGREES.

BASED ON THE USER'S DETERMINED MAX HORIZ, VERT, & AXIAL FORCES, THE USER MUST SELECT THE APPROPRIATE SEISMIC BRACE CLAMP(S) FROM SECTION 5. THE SEISMIC BRACE CLAMP'S DESIGN LOAD CAPACITY, FOR THE GIVEN PIPE SIZE, MUST BE GREATER THAN THE MAX USER CALCULATED FORCES.

AFTER SELECTING A SEISMIC BRACE CLAMP FROM SECTION 5, THE USER IS TO SELECT THE APPROPRIATE BRACE PIPE AS PER TABLES 1.2.2 & 1.2.3, & THE APPROPRIATE ATTACHMENT TO SUPPORTING STRUCTURE FROM SECTIONS 2, 3, OR 4. THE ATTACHMENT'S DESIGN LOAD CAPACITY, FOR THE GIVEN PIPE SIZE, MUST BE GREATER THAN THE MAX USER CALCULATED FORCES.

SEE SECTION 8 FOR AN EXAMPLE OF A TYP SWAY BRACE DESIGN PROCEDURE.

1.4.1. THIS PRE-APPROVAL MAY BE USED FOR THE DESIGN OF SEISMIC SWAY BRCG OF INTERIOR FIRE SPRINKLER SYSTEMS. A CLSE HAS DESIGNED THIS PRE-APPROVAL, ALONG W/ SUPPORTING CALCULATIONS. THEREFORE, THE PRE-APPROVED DETAILS & CALCULATIONS ARE NOT TO BE RE-REVIEWED BY OSHPD REGIONAL STAFF. HOWEVER, EA FIRE SPRINKLER SYSTEM REQUIRES SUBMITTALS THAT MUST BE REVIEWED & APPROVED BY OSHPD.

1.4.2. AS W/ ALL PRE-APPROVED DETAILS, SYSTEMS, ETC., PLANS ARE STILL REQ SHOWING HOW & WHERE THIS PRE-APPROVED ANCHORAGE & BRCG SYSTEM WILL BE APPLIED TO THE FIRE SPRINKLER SYSTEM ON A PROJECT SPECIFIC BASIS. THIS PROCESS IS NEEDED TO VERIFY THAT THE APPROPRIATE DETAIL HAS BEEN SELECTED & APPLIED FOR EA CONDITION & FOR THE ACTUAL SUBSTRATE THAT IT WILL BE CONNECTED/ATTACHED TO. FOR THE FIRE SPRINKLER SYSTEM, THESE LAYOUT PLANS MUST BE PREPARED BY A CRDP. SEE CALIFORNIA ADMINISTRATIVE CODE (CAC) 2013, TITLE 24, PART 1, SECTION 7-115.

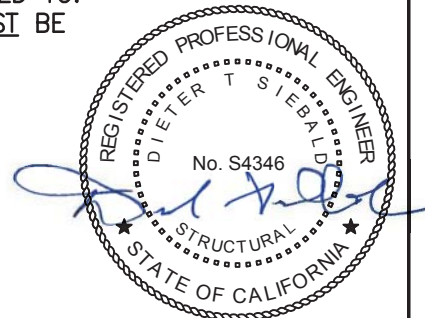

SHEET TITLE: GENERAL INFORMATION
USING ANVIL INTERNATIONAL'S PRE-APPROVAL GUIDE



CYS STRUCTURAL ENGINEERS, INC.

2495 NATOMAS PARK DRIVE, SUITE 650
SACRAMENTO, CA 95833

TEL (916) 920-2020
www.cyseng.com

Job No:	14090
Date:	09-22-2016
Page:	13 of 60

L:\Jobs\14090 Anvil - Fire Sprinkler System OPM-0351-13\ACAD\STRU\S1.dwg Time:Sep22,2016-02:15pm Login:camachom Dimstyle:1 LTScale:4

SEISMIC SWAY BRACING FOR FIRE PROTECTION SYSTEMS

1.4. USING ANVIL INTERNATIONAL'S PRE-APPROVAL GUIDE (CONTINUED)

- 1.4.3. THE PRE-APPROVED DETAILS CONTAINED WITHIN THIS PRE-APPROVAL HAVE RELATED TABLES & CHARTS WHICH MUST BE USED TO SELECT THE APPROPRIATE DETAIL FOR EA LOCATION THAT AN ANCHOR OR BRACE IS TO BE INSTALLED. THE APPLICATION OF THESE CRITERIA SHOULD NEVER BECOME THE RESPONSIBILITY OF THE "INSPECTOR OF RECORD" (IOR), WHOSE RESPONSIBILITY IS TO INSPECT ONLY, NOT DESIGN.
- 1.4.4. THE OSHPD REGIONAL STAFF, ON A PROJECT SPECIFIC BASIS, MUST REVIEW SUPPORTS, ATTACHMENTS & BRCG DETAILS & SUPPORTING CALCULATIONS THAT ARE NOT PART OF THIS PRE-APPROVAL. REVIEW OF SUPPORTS, ATTACHMENTS & BRCG DETAILS OF THIS NATURE DO NOT CONSTITUTE A PRE-APPROVAL THAT MAY BE USED ON OTHER PROJECTS WITHOUT THE BENEFIT OF PLAN REVIEW.
- 1.4.5. LAYOUT DRAWINGS:
 - 1.4.5.1. LAYOUT DRAWINGS OF THE SUPPORT ATTACHMENTS, & BRCG SYSTEMS PER THIS PRE-APPROVAL SHALL BE SUBMITTED TO THE DISCIPLINE IN RESPONSIBLE CHARGE OF THE PROJECT FOR REVIEW TO VERIFY THAT THE DETAILS ARE IN CONFORMANCE W/ ALL CODE REQUIREMENTS. THE LAYOUT DRAWINGS SHALL BE IN ACCORDANCE W/ ASCE 7-10 SECTION 13.6 (INCLUDING SUPPLEMENTS 1 & 2) AS MODIFIED BY CBC 2013 SECTION 1616A.
 - 1.4.5.1.1. THE SEOR SHALL VERIFY THAT THE SUPPORTING STRUCTURE IS ADEQUATE FOR THE LOADS IMPOSED ON IT BY THE SUPPORTS & BRACES INSTALLED PER THE PRE-APPROVAL IN ADDITION TO ALL OTHER DESIGN LOADS.
 - 1.4.5.1.2. THE SEOR MUST REVIEW & FORWARD THE SUPPORTS, ATTACHMENTS & BRCG PLANS (INCLUDING APPROVED CHANGE ORDERS FOR THE SUPPLEMENTARY FRAMING WHERE REQ) FOR PLAN CHECK W/ A NOTATION INDICATING THAT THE PLANS HAVE BEEN REVIEWED & ARE IN GENERAL CONFORMANCE W/ THIS PRE-APPROVAL, THE DESIGN OF THE PROJECT (CAC 2013, SECTION 7-153), & NFPA 13, 2013 EDITION.
 - 1.4.5.1.3. A "SHOP DRAWING STAMP" MAY BE USED TO INDICATE COMPLIANCE W/ THE REQUIREMENT IN 1.4.5.1.2.
 - 1.4.5.1.4. THE CALIFORNIA REGISTERED DESIGN PROFESSIONAL (CRDP OTHER THAN THE SEOR) MAY PROVIDE THE SHOP DRAWING STAMP FOR SMALL INSTALLATIONS AT THE DISCRETION OF THE OSHPD DISTRICT STRUCTURAL ENGINEER.

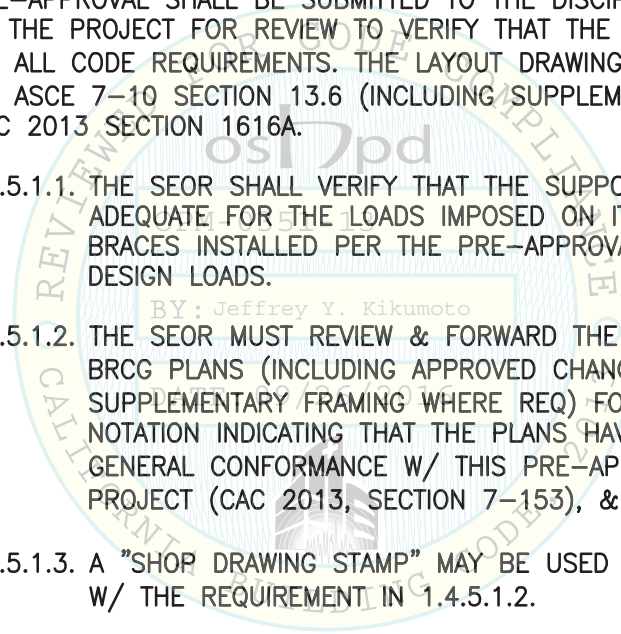

SHEET TITLE: GENERAL INFORMATION
 USING ANVIL INTERNATIONAL'S PRE-APPROVAL GUIDE

 CYS STRUCTURAL ENGINEERS, INC. 2495 NATOMAS PARK DRIVE, SUITE 650 SACRAMENTO, CA 95833	TEL (916) 920-2020 www.cyseng.com	Job No: 14090 Date: 09-22-2016 Page: 14 of 60
---	--------------------------------------	---

L:\Jobs\14090 Anvil - Fire Sprinkler System OPM-0351-13\ACAD\STRU\S1.dwg Time:Sep22,2016-02:15pm Login:camachom DimScale:1 LScale:4

SEISMIC SWAY BRACING FOR FIRE PROTECTION SYSTEMS

1.4. USING ANVIL INTERNATIONAL'S PRE-APPROVAL GUIDE (CONTINUED)

- 1.4.5.2. THE SEOR SHALL DESIGN ANY SUPPLEMENTARY FRAMING THAT IS NEEDED TO RESIST THE LOADS, MAINTAIN STABILITY &/OR IS REQ FOR INSTALLATION OF THIS PRE-APPROVAL. THE SUPPLEMENTARY FRAMING SHALL BE SUBMITTED TO OSHPD AS AN AMENDED CONSTRUCTION DOCUMENT (ACD).
- 1.4.5.3. THE LAYOUT DRAWINGS (W/ THE SHOP DRAWING STAMP) SHALL BE SUBMITTED TO OSHPD FOR REVIEW OF THE FOLLOWING:
 - a. STRUCTURE SUPPORTING THE DISTRIBUTION SYSTEM HAS ADEQUATE CAPACITY.
 - b. SEISMIC DESIGN FORCES (F_p) & (F_{pv}) ARE IN ACCORDANCE W/ CBC 2013 & W_p SHALL COMPLY W/ NFPA 13 PROVISIONS.
 - c. VERIFY THAT THE SUBMITTAL IS WITHIN THE SCOPE OF OPM.
 - SIZE & DISTRIBUTION SYSTEM COMPONENTS
 - SPCG & BRCG OF FLEX JOINTS CLEARLY IDENTIFIED WHERE THEY OCCUR, &
 - SUBSTRATE FOR ATTACHMENT
- 1.0.5.1. THE LAYOUT DRAWINGS (W/ THE SHOP DRAWING STAMP) SHALL BE KEPT ON THE JOBSITE & MAY BE USED AS REFERENCE FOR INSTALLATION FOR THE SUPPORTS & BRCG CONTAINED WITHIN THIS PRE-APPROVAL. OSHPD FIELD STAFF WILL REVIEW THE INSTALLATION.
- 1.0.5.2. A COPY OF THIS PRE-APPROVAL SHALL BE ON THE JOBSITE PRIOR TO STARTING THE INSTALLATION OF HANGERS &/OR BRACES. THE IOR & THE CONTRACTOR SHALL EA OBTAIN A COPY OF THIS PRE-APPROVAL FROM THE OSHPD PRE-APPROVAL PROGRAMS WEBSITE.
- 1.0.5.3. COMPONENTS OF TWO OR MORE PRE-APPROVED BRCG SYSTEMS SHALL NOT BE MIXED. ONLY THIS PRE-APPROVAL MAY BE USED FOR THE FIRE SPRINKLER SYSTEM. ANY SUBSTITUTION OF COMPONENT OF THIS PRE-APPROVAL SHALL REQUIRE OSHPD REVIEW & APPROVAL.

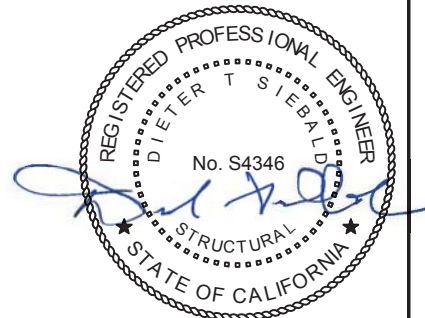
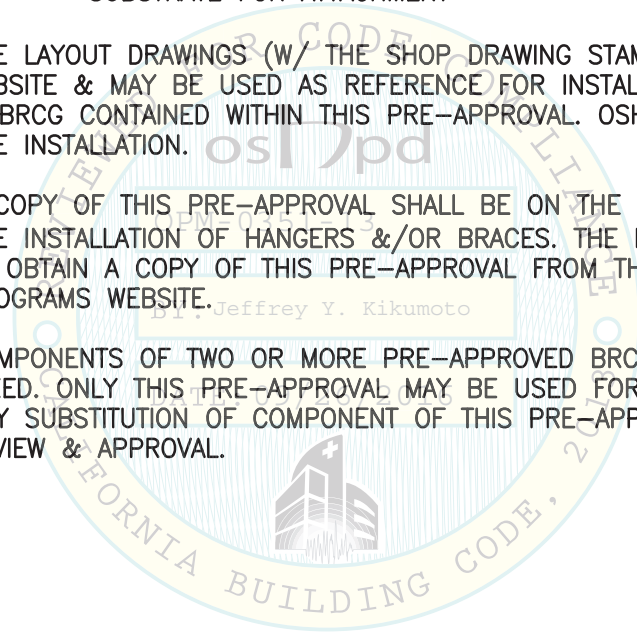

L:\Jobs\14090 Anvil - Fire Sprinkler System OPM-0351-13\ACAD\STRU\S1.dwg Time:Sep22,2016 -02:15pm Login:camachom DimScale:1 LTScale:4

SHEET TITLE: GENERAL INFORMATION
 USING ANVIL INTERNATIONAL'S PRE-APPROVAL GUIDE

 CYS STRUCTURAL ENGINEERS, INC. 2495 NATOMAS PARK DRIVE, SUITE 650 SACRAMENTO, CA 95833	TEL (916) 920-2020 www.cyseng.com	Job No: 14090 Date: 09-22-2016 Page: 15 of 60
---	--------------------------------------	---

SEISMIC SWAY BRACING FOR FIRE PROTECTION SYSTEMS

1.5. SEISMIC DESIGN CRITERIA

THE SEISMIC DEMAND CALCULATION IN THIS REPORT USES THE METHOD FROM NFPA 13 ANNEX E.3 "COMPUTING THE SEISMIC DEMAND ON PIPING SYSTEMS". THE SEISMIC FORCES ARE DETERMINED TO CONFORM TO THE METHOD IN ASCE 7-10. THIS SECTION SHOWS THE DESIGN CRITERIA, HOW THE LRFD SEISMIC FORCE IS CALCULATED USING THE METHODS IN ASCE 7-10, & HOW THE CALCULATED LRFD FORCE IS CONVERTED TO THE ASD FORCE USED IN NFPA 13.

VARIABLE	DESCRIPTION	VALUE
α_p	COMPONENT AMPLIFICATION FACTOR, TAKEN AS 2.5 FOR PIPING SYSTEMS	2.5
I_p	COMPONENT IMPORTANCE FACTOR, TAKEN AS 1.5 FOR FIRE SPRINKLER SYSTEMS (EMERGENCY SYSTEMS – PIPING NOT IN CONFORMANCE W/ ASME B31)	1.5
R_p	COMPONENT RESPONSE MODIFICATION FACTOR, TAKEN AS FOLLOWS:	
	<ul style="list-style-type: none"> • HIGH-DEFORMABILITY PIPING W/ JOINTS MADE BY WELDING OR BRAZING • HIGH OR LIMITED-DEFORMABILITY PIPING W/ JOINTS MADE BY THREADING, BONDING, COMPRESSION COUPLINGS, OR GROOVED COUPLINGS. 	9 4.5
S_{Ds}	SHORT PERIOD SPECTRAL ACCELERATION IS TAKEN AS NOT GREATER THAN 2.5 FOR THE STATE OF CALIFORNIA. CRDP SHALL DETERMINE SITE SPECIFIC S_{Ds}	2.5
Ω_0	OVERSTRENGTH FACTOR FOR ANCHORAGE TO CONC	2.5
z	HT OF THE COMPONENT ATTACHMENT W/ RESPECT TO THE BASE	USER DEFINED
h	AVERAGE ROOF HT OF THE STRUCTURE W/ RESPECT TO THE BASE	USER DEFINED
W_p^1	COMPONENT OPERATING WT : 09/26/2016	USER DEFINED
F_p	LRFD HORIZ SEISMIC DESIGN FORCE	OUTPUT
F_{pw}	NFPA-13 ASD HORIZ SEISMIC DESIGN FORCE ($F_{pw}=0.7F_p$)	OUTPUT

¹ PER NFPA 13 SECTION 9.3.5.9.2, THE WT OF SYSTEM BEING BRACED (W_p) SHALL BE TAKEN AS 1.15 TIMES THE WT OF THE WATER-FILLED PIPING. THE FACTOR IS INTENDED TO APPROXIMATE THE ADDNL WT OF ALL THE VALVES, FITTINGS, & OTHER DEVICES ATTACHED TO THE SYSTEM.

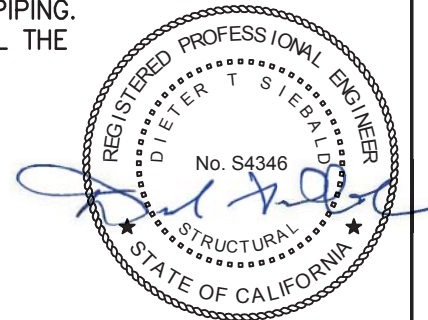

SHEET TITLE: GENERAL INFORMATION
SEISMIC DESIGN CRITERIA



CYS STRUCTURAL ENGINEERS, INC.

2495 NATOMAS PARK DRIVE, SUITE 650
SACRAMENTO, CA 95833

TEL (916) 920-2020
www.cyseng.com

Job No:	14090
Date:	09-22-2016
Page:	16 of 60

SEISMIC SWAY BRACING FOR FIRE PROTECTION SYSTEMS

1.5. SEISMIC DESIGN CRITERIA (CONTINUED)

1.5.1. HORIZ SEISMIC DESIGN FORCE (F_p) PER ASCE 7-10, SECTION 13.3.1

F_p SHALL BE TAKEN AS:

$$F_p = 0.4 a_p S_{DS} I_p W_p (1+2z/h)/R_p$$

F_p SHALL NOT BE TAKEN AS LESS THAN:

$$F_p (\text{min}) = 0.3 S_{DS} I_p W_p$$

AND F_p IS NOT REQ TO BE TAKEN AS GREATER THAN:

$$F_p (\text{max}) = 1.6 S_{DS} I_p W_p$$

NOTE: VERT SEISMIC LOAD EFFECT IS APPLIED AS A DEAD LOAD FACTOR ADJUSTMENT & IS ACCOUNTED FOR IN THE ASD & LRFD LOAD COMBINATIONS BLW.

1.5.2. DETERMINE FORCES

ASSUMING THE USE OF GROOVED COUPLINGS, $R_p = 4.5$ AND $a_p = 2.5$

ASSUMING MAX HT OF COMPONENT, $z/h \leq 1$

ASSUMING MAX S_{DS} FOR THE STATE OF CALIFORNIA, $S_{DS} = 2.50$

$$F_p = 0.4(2.5)(2.50)(1.5)W_p(3)/4.5$$

$$F_p = 2.50W_p \text{ GOVERNS DESIGN}$$

$$F_p(\text{min}) = 0.3(2.50)(1.5)W_p$$

$$F_p(\text{min}) = 1.125W_p$$

$$F_p(\text{max}) = 1.6(2.50)(1.5)W_p$$

$$F_p(\text{max}) = 6.00W_p$$

1.5.3. ASD LOAD COMBINATIONS FOR SUPPORTS & ATTACHMENTS EXCEPT CONC ANCHORS

$$1.5.3.1. (1.0 + 0.14 S_{DS}) W_p \pm 0.7 F_p$$

$$1.5.3.2. (0.6 - 0.14 S_{DS}) W_p \pm 0.7 F_p$$

1.5.4. LRFD LOAD COMBINATIONS FOR CONC ANCHORS

$$1.5.4.1. (1.2 + 0.2 S_{DS}) W_p \pm \Omega_0 F_p$$

$$1.5.4.2. (0.9 - 0.2 S_{DS}) W_p \pm \Omega_0 F_p$$

1.5.5. CONVERTING FROM LRFD TO ASD

TO CONVERT TO THE NFPA 13 ASD HORIZ SEISMIC DESIGN FORCE (F_{pw}), THE ASCE 7 LRFD HORIZ SEISMIC DESIGN FORCE (F_p) IS MULTIPLIED BY A LOAD FACTOR OF 0.7. ASSUMING THE USE OF VARIABLES FROM SECTION 1.5.2 ABV, IT FOLLOWS:

$$F_{pw} = 0.7F_p = (0.7)(2.50W_p)$$

$$F_{pw} = 1.75W_p$$



SHEET TITLE: GENERAL INFORMATION
SEISMIC DESIGN CRITERIA



CYS STRUCTURAL ENGINEERS, INC.

2495 NATOMAS PARK DRIVE, SUITE 650
SACRAMENTO, CA 95833

TEL (916) 920-2020
www.cyseng.com

Job No:	14090
Date:	09-22-2016
Page:	17 of 60

SEISMIC SWAY BRACING FOR FIRE PROTECTION SYSTEMS

1.6. ALLOWABLE CAPACITIES OF SEISMIC BRACE COMPONENTS

ALLOWABLE CAPACITIES OF SEISMIC BRACE COMPONENTS ARE BASED ON TESTING PER THE FM APPROVAL STD FOR SEISMIC SWAY BRACES FOR AUTOMATIC SPRINKLER SYSTEMS, CLASS NUMBER 1950, MARCH 2010, & EFFECTIVE DATE OF JUNE 30, 2010. FM CERTIFICATES OF COMPLIANCE HAVE BEEN FILED W/ OSHPD. SEE TABLE 1.6.1

APPROVAL IDENTIFICATION NUMBERS	APPROVAL GRANTED	ANVIL FIGURE NUMBERS
3039348	MAY 17, 2011	770, 772, 776
3041475	MAY 16, 2011	771, 775
3047205	JANUARY 2, 2013	778

TABLE 1.6.1 – FM CERTIFICATES OF COMPLIANCE

ALLOWABLE CAPACITY OF BRACE SUB-ASSEMBLIES HAVE BEEN DETERMINED BY RESOLVING THE LOAD RATING (I.E. THE LOAD RESULTING IN FAILURE OR EXCEEDING OF DEFORMATION LIMITS) TO THE HORIZ DIRECTION & DIVIDING BY 1.5 TO ALLOW VALUES TO BE USED DIRECTLY FOR ASD. FOR LRFD CAPACITIES, THE VALUES WILL NEED TO BE MULTIPLIED BY 1.5.

1.7. CERTIFICATES OF COMPLIANCE

- 1.7.1. ALLOWABLE HORIZ CAPACITY FOR THINNER WALLED SERVICE PIPES MAY BE USED FOR THICKER WALLED PIPES. HOWEVER, ALLOWABLE HORIZ CAPACITY FOR THICKER WALLED SERVICE PIPES SHALL NOT BE USED FOR THINNER WALLED PIPES.
- 1.7.2. LOAD RATINGS FOR LW PIPE REFERS TO FM APPROVED LW PIPE, COMMONLY REFERRED TO AS SCHED 7. THESE RATINGS MAY ALSO BE APPLIED TO EN10220 & GB/T 8163 PIPE.
- 1.7.3. LOAD RATING FOR SCHED 10 MAY BE APPLIED TO GB/T 3091, GB/T 3092, EN 10255 M & H, JIS G3452, FM APPROVED THIN WALL & SCHED 40 PIPE.
- 1.7.4. COMPONENTS 770, 771, 775, & 776 FM APPROVED WHEN USED W/ 1" OR 1¼" SCHED 40, GB/T 3091, EN 10255 H, & JIS G3454 BRACE PIPE.
- 1.7.5. FM APPROVALS DO NOT APPROVE SEISMIC BRCG PRODUCTS FOR USE W/ 8" NPS SERVICE PIPE W/ A WALL THK LESS THAN 0.188". ASME B36.10M-2004 DEFINES SCHED 10 MIN WALL THK FOR 8" NPS SERVICE PIPES AS 0.134". THEREFORE, CERTIFICATES OF COMPLIANCE SPECIFY THE PIPE AS "0.188" RATHER THAN "SCHED 10". IT IS TYP IN THE UNITED STATES THAT 8" NPS PIPE THAT IS MARKETED AS "SCHED 10" HAS A WALL THK OF 0.188", WHICH IS GREATER THAN THE MIN WALL THK SPECIFIED BY ASME B36.10M-2004.



SHEET TITLE: GENERAL INFORMATION:

ALLOWABLE CAPACITIES OF SEISMIC BRACE COMPONENTS & CERTIFICATES OF COMPLIANCE

 <p>CYS STRUCTURAL ENGINEERS, INC. 2495 NATOMAS PARK DRIVE, SUITE 650 SACRAMENTO, CA 95833</p>	TEL (916) 920-2020	Job No: 14090
	www.cyseng.com	Date: 09-22-2016
		Page: 18 of 60

L:\Jobs\14090 Anvil - Fire Sprinkler System OPM-0351-13\ACAD\STRU\S1.dwg Time:Sep22,2016-02:16pm Login:camachom DimScale:1 LTScale:4

SEISMIC SWAY BRACING FOR FIRE PROTECTION SYSTEMS

2. ANCHORAGES TO CONCRETE STRUCTURE:

2.1. EXPANSION ANCHORS

2.1.1. EXPANSION ANCHORS INSTALLED IN NWC, OR TO THE UNDERSIDE (SOFFIT) OF CONC FILLED (NWC OR SLWC) PROFILE MTL DECK ASSEMBLIES, SHALL BE EITHER:

HILTI KWIK BOLT TZ CARBON STEEL (KB-TZ) EXPANSION ANCHORS
PER ICC ESR-1917, REISSUED MAY 2015

ITW REDHEAD CARBON STEEL TRUBOLT+ WEDGE ANCHORS
PER ICC ESR-2427, REISSUED NOVEMBER 2015

POWERS POWER-STUD+ SD1 CARBON STEEL EXPANSION ANCHORS
PER ICC ESR-2818, REISSUED DECEMBER 2015.

INSTALLATION SHALL COMPLY W/ CBC SECTION 1616A.1.19. OTHER TYPES & BRANDS OF EXPANSION ANCHORS MAY BE USED PROVIDED THEIR CAPABILITIES & STRENGTHS ARE EQ OR BETTER THAN THE ABV SPECIFIED ANCHORS, & ALL HAVE CURRENT ICC REPORTS W/ CRACKED CONC COMPLIANCE IN ACCORDANCE W/ AC193 ACCEPTANCE CRITERIA FOR MECHANICAL ANCHORS IN CONC ELEMENTS. AN OSHPD CHANGE ORDER IS REQ FOR ANY SUBSTITUTION OF A SPECIFIED MECHANICAL ANCHOR.

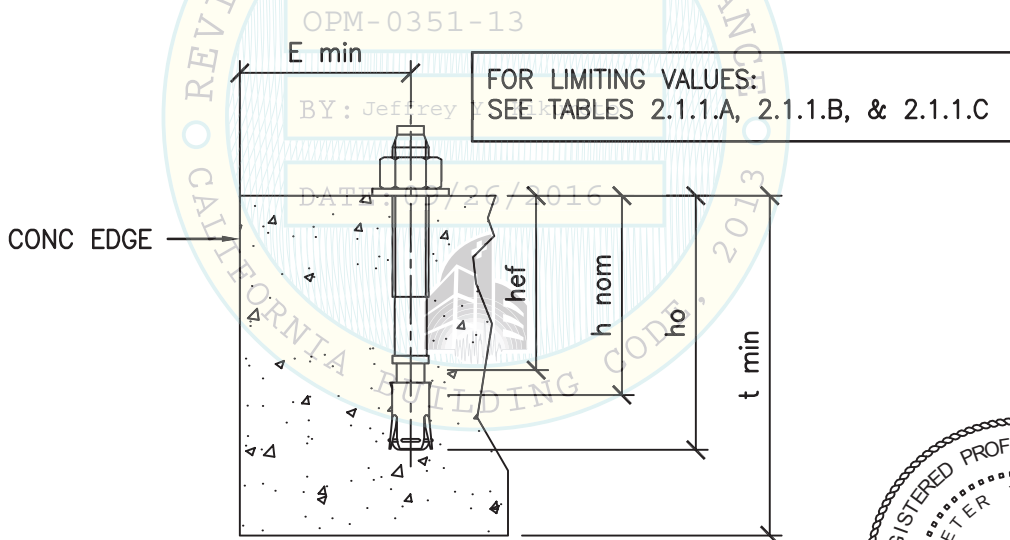

FIGURE 2.1.1 - ANCHOR INSTALLATION INFO



SHEET TITLE: ANCHORAGES TO CONCRETE STRUCTURE
EXPANSION ANCHORS



CYS STRUCTURAL ENGINEERS, INC.

2495 NATOMAS PARK DRIVE, SUITE 650
SACRAMENTO, CA 95833

TEL (916) 920-2020
www.cyseng.com

Job No:	14090
Date:	09-22-2016
Page:	19 of 60

L:\Jobs\14090 Anvil - Fire Sprinkler System OPM-0351-13\ACAD\STRU\S1.dwg Time:Sep22,2016-02:16pm Login:camachom Dimscale:1 LScale:4

SEISMIC SWAY BRACING FOR FIRE PROTECTION SYSTEMS

2.1. EXPANSION ANCHORS (CONTINUED)

INSTALLATION INFO	SYMBOL	½" NOMINAL ANCHOR DIA (INCH)	
EFFECTIVE MIN EMBEDMENT	hef	2	¾
NOMINAL EMBEDMENT	h nom	2⅜	3⅝
MIN HOLE DEPTH	ho	2⅝	4
MIN CONC THK	t min	4	6
MIN EDGE DISTANCE ¹	E min	6	6

TABLE 2.1.1.A – HILTI KWIK BOLT TZ INSTALLATION INFO PER ICC-ES REPORT ESR-1917 TABLE 1 & TABLE 3

¹ EDGE DISTANCE USED IN DESIGN TO OBTAIN ALLOWABLE SHEAR & TENSION VALUES.

INSTALLATION INFO	SYMBOL	½" NOMINAL ANCHOR DIA (INCH)	
EFFECTIVE MIN EMBEDMENT	hef	2	¾
NOMINAL EMBEDMENT	h nom	2½	3¾
MIN HOLE DEPTH	ho	2¾	4
MIN CONC THK	t min	4	6
MIN EDGE DISTANCE ¹	E min	6	6

TABLE 2.1.1.B – ITW REDHEAD TRUBOLT+ INSTALLATION INFO PER ICC-ES REPORT ESR-2427 TABLE 2

¹ EDGE DISTANCE USED IN DESIGN TO OBTAIN ALLOWABLE SHEAR & TENSION VALUES.

INSTALLATION INFO	SYMBOL	½" NOMINAL ANCHOR DIA (INCH)	
EFFECTIVE MIN EMBEDMENT	hef	2	¾
NOMINAL EMBEDMENT	h nom	2½	3¾
MIN HOLE DEPTH	ho	2¾	4
MIN CONC THK	t min	4	6
MIN EDGE DISTANCE ¹	E min	6	6

TABLE 2.1.1.C – POWERS POWER-STUD+ SD1 INSTALLATION INFO PER ICC-ES REPORT ESR-2818 TABLE 1

¹ EDGE DISTANCE USED IN DESIGN TO OBTAIN ALLOWABLE SHEAR & TENSION VALUES.



**SHEET TITLE: ANCHORAGES TO CONCRETE STRUCTURE
EXPANSION ANCHORS**

 CYS STRUCTURAL ENGINEERS, INC. 2495 NATOMAS PARK DRIVE, SUITE 650 SACRAMENTO, CA 95833	TEL (916) 920-2020 www.cyseng.com	Job No: 14090 Date: 09-22-2016 Page: 20 of 60
---	--------------------------------------	---

L:\Jobs\14090 Anvil - Fire Sprinkler System OPM-0351-13\ACAD\STRU\S1.dwg Time:Sep22,2016-02:16pm Login:camachom DimScale:1 LTScale:4

SEISMIC SWAY BRACING FOR FIRE PROTECTION SYSTEMS

2.1. **EXPANSION ANCHORS (CONTINUED)**

2.1.2. EXPANSION ANCHOR TESTING

- 2.1.2.1. ALL TESTS SHALL BE CONDUCTED BY A TESTING LABORATORY CONTRACTED BY THE FACILITY IN THE PRESENCE OF THE SPECIAL INSPECTOR & THE IOR. A REPORT OF THE TEST RESULTS SHALL BE SUBMITTED TO THE ENFORCEMENT AGENCY.
- 2.1.2.2. TESTING MAY BE DONE PRIOR TO SEISMIC BRACE INSTALLATION.
- 2.1.2.3. REFER TO THE 2013 CBC, SECTION 1913A.7 "TESTS FOR POST-INSTALLED ANCHORS IN CONCRETE" FOR DETERMINATION OF TEST LOAD & ACCEPTANCE CRITERIA. TEST LOADS ARE GIVEN IN TABLES 2.1.2.A & 2.1.2.B & ACCEPTANCE CRITERIA IS GIVEN IN SECTION 2.1.2.7 BLW.
- 2.1.2.4. EXPANSION ANCHORS SHALL HAVE 50 PERCENT OF THE INSTALLED ANCHORS PROOF TESTED. IF ANY ANCHOR FAILS TESTING, TEST 20 CONSECUTIVE ANCHORS, ALL INSTALLED BY THE SAME TRADE, UNTIL 20 CONSECUTIVE ANCHORS PASS. ONLY AFTER 20 CONSECUTIVE ANCHORS PASS SHALL THE 50 PERCENT TESTING RESUME.
- 2.1.2.5. TESTING SHALL OCCUR A MIN OF 24 HOURS AFTER ANCHOR INSTALLATION.
- 2.1.2.6. TEST EQUIPMENT SHALL BE CALIBRATED BY AN APPROVED TESTING & CALIBRATION FACILITY.
- 2.1.2.7. THERE ARE TWO ACCEPTABLE TEST METHODS, HYDRAULIC RAM & TORQUE WRENCH METHOD.
 - **HYDRAULIC RAM METHOD:**
DIRECT PULL W/ A HYDRAULIC JACK OR CALIBRATED SPRING LOADING DEVICE. APPLY & HOLD TEST LOAD FOR A MIN OF 15 SECONDS. THE ANCHOR SHALL HAVE NO OBSERVABLE MOVEMENT AT THE APPLICABLE TEST LOAD WHERE WASHERS ARE USED. A PRACTICAL WAY TO DETERMINE OBSERVABLE MOVEMENT IS THAT THE WASHER UNDER THE NUT BECOMES LOOSE.
 - **TORQUE WRENCH METHOD:**
MFR'S TORQUE CRITERIA TESTING MUST BE REACHED WITHIN 1/2 TURN OF THE NUT.

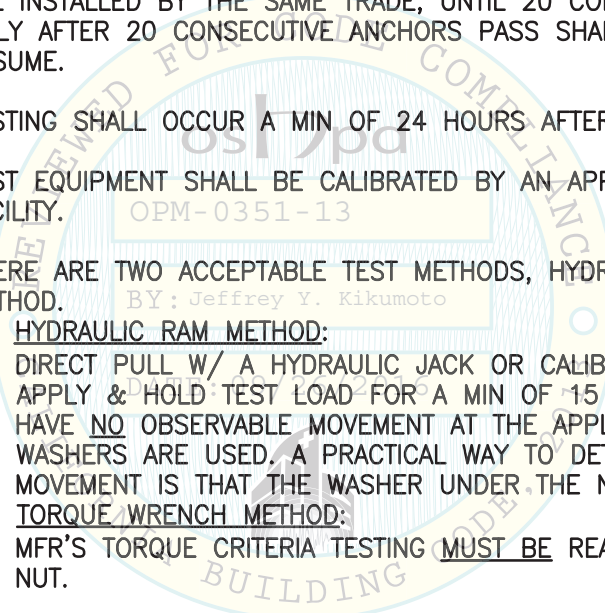

L:\Jobs\14090 Anvil - Fire Sprinkler System OPM-0351-13\ACAD\STRU\S1.dwg Time:Sep22,2016-02:16pm Login:camachom DimScale:1 LTScale:4

SHEET TITLE: ANCHORAGES TO CONCRETE STRUCTURE
EXPANSION ANCHORS

 CYS STRUCTURAL ENGINEERS, INC. 2495 NATOMAS PARK DRIVE, SUITE 650 SACRAMENTO, CA 95833	TEL (916) 920-2020 www.cyseng.com	Job No: 14090 Date: 09-22-2016 Page: 21 of 60
---	--------------------------------------	---

SEISMIC SWAY BRACING FOR FIRE PROTECTION SYSTEMS

2.1. EXPANSION ANCHORS (CONTINUED)

CONC STRENGTH f'c (PSI)	EFFECTIVE MIN EMBEDMENT (hef) - 2"						EFFECTIVE MIN EMBEDMENT (hef) - 3/4"					
	TENSION TEST LOAD (LBS) ¹			TORQUE (FT-LBS)			TENSION TEST LOAD (LBS) ¹			TORQUE (FT-LBS)		
	HILTI	ITW	POWERS	HILTI	ITW	POWERS	HILTI	ITW	POWERS	HILTI	ITW	POWERS
3000	890	1085	1456	40	45	40	1597	2453	1456	40	45	40

TABLE 2.1.2.A - TESTING CRITERIA FOR 1/2" DIA ANCHORS IN SOFFIT OF MTL DECK W/ NWC OR SLWC, SEE FIGURE 2.1.2 BLW

¹ APPLY PROOF TENSION TEST LOAD TO ANCHOR WITHOUT REMOVING THE NUT IF POSSIBLE.

CONC STRENGTH f'c (PSI)	EFFECTIVE MIN EMBEDMENT (hef) - 2"						EFFECTIVE MIN EMBEDMENT (hef) - 3/4"					
	TENSION TEST LOAD (LBS) ¹			TORQUE (FT-LBS)			TENSION TEST LOAD (LBS) ¹			TORQUE (FT-LBS)		
	HILTI	ITW	POWERS	HILTI	ITW	POWERS	HILTI	ITW	POWERS	HILTI	ITW	POWERS
3000	1605	1605	1605	40	45	40	3281	3324	1672	40	45	40
4000	1853	1853	1853	40	45	40	3788	3839	1931	40	45	40

TABLE 2.1.2.B - TESTING CRITERIA FOR 1/2" DIA ANCHORS IN NWC

¹ APPLY PROOF TENSION TEST LOAD TO ANCHOR WITHOUT REMOVING THE NUT IF POSSIBLE.

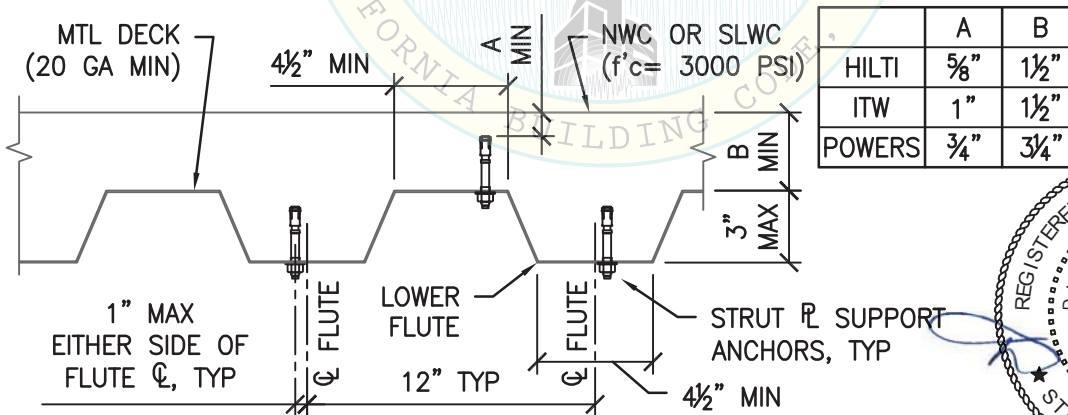

FIGURE 2.1.2 - ANCHOR IN SOFFIT OF MTL DECK



SHEET TITLE: ANCHORAGES TO CONCRETE STRUCTURE
EXPANSION ANCHORS



CYS STRUCTURAL ENGINEERS, INC.

2495 NATOMAS PARK DRIVE, SUITE 650
SACRAMENTO, CA 95833

TEL (916) 920-2020
www.cyseng.com

Job No: 14090
Date: 09-22-2016
Page: 22 of 60

L:\Jobs\14090 Anvil - Fire Sprinkler System OPM-0351-13\ACAD\STRU\S1.dwg Time:Sep22,2016 -02:16pm Login:camachom Dimscale:1 LTScale:4

SEISMIC SWAY BRACING FOR FIRE PROTECTION SYSTEMS

2.2. SUPPORTS & ATTACHMENTS

2.2.1. ELEVATED SLAB & VERT FACE OF WALLS & BMS.

2.2.1.1. BRACE ANGLE (θ) PER NFPA FIGURE 9.3.5.12.1.

2.2.1.2. SEE TABLE 2.2.1 FOR ADDNL ANCHOR INSTALLATION INFO.

2.2.1.3. SEE SECTION 4.1 FOR ADDNL INFO ON ANVIL FIGURE 771 INSTALLATION.

2.2.1.4. INTERACTION OF TENSILE & SHEAR FORCES SHALL BE VERIFIED BY THE CRDP PER THE ICC REPORTS & ACI 318-11 APPENDIX D. SEOR SHALL VERIFY THE SUITABILITY OF THE STRUCTURE FOR DETERMINED LOADS.

2.2.1.5. STRENGTH DESIGN CAPACITIES IN SHEAR & TENSION ARE PROVIDED FOR ANCHORS INSTALLED IN CONC OF MIN COMPRESSIVE STRENGTH AS LISTED IN TABLE 2.2.1 AT THE TIME OF INSTALLATION. THE CAPACITIES WERE DETERMINED FOR ANCHORS IN CRACKED CONC PER THE ICC REPORTS OF THE MFR'S LISTED IN SECTION 2.1.1 & ARE PRESENTED ONLY AS AN AID TO THE CRDP. THE CRDP MAY COMPUTE CONC ANCHOR CAPACITIES PER ICC REPORTS & ACI 318-11 APPENDIX D FOR ANY CONDITION NOT COVERED.

2.2.1.6. WHEN INSTALLING ANCHORS, AVOID DAMAGING REINF OR PRE-STRESSING STL.

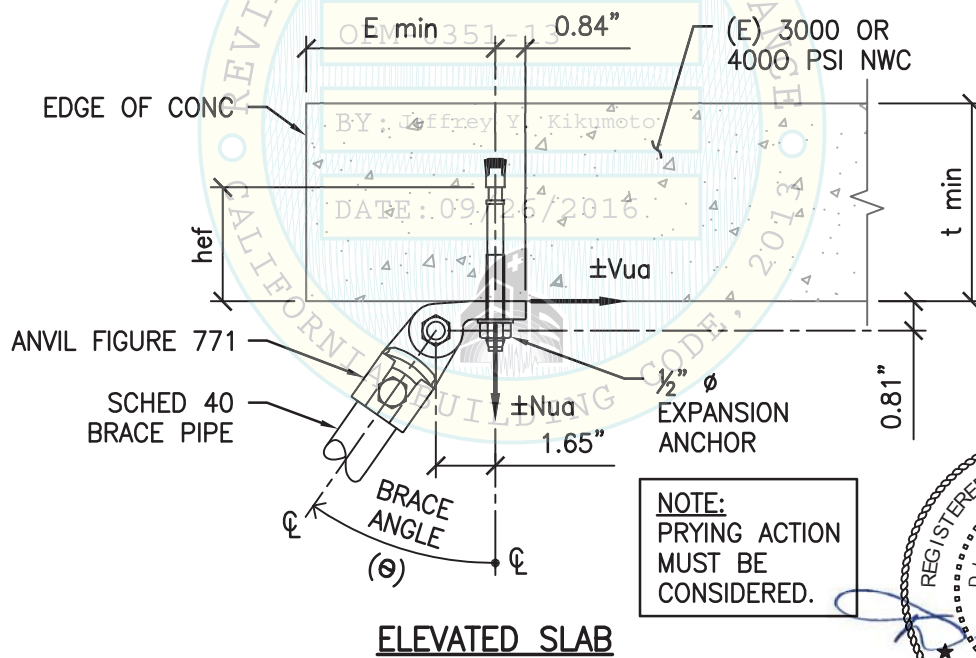

FIGURE 2.2.1a – ANCHORING DETAILS FOR
3000 PSI & 4000 PSI NWC

SHEET TITLE: ANCHORAGES TO CONCRETE STRUCTURE
SUPPORTS & ATTACHMENTS



CYS STRUCTURAL ENGINEERS, INC.

2495 NATOMAS PARK DRIVE, SUITE 650
SACRAMENTO, CA 95833

TEL (916) 920-2020
www.cyseng.com

Job No:	14090
Date:	09-22-2016
Page:	23 of 60

SEISMIC SWAY BRACING FOR FIRE PROTECTION SYSTEMS

2.2. SUPPORTS & ATTACHMENTS (CONTINUED)

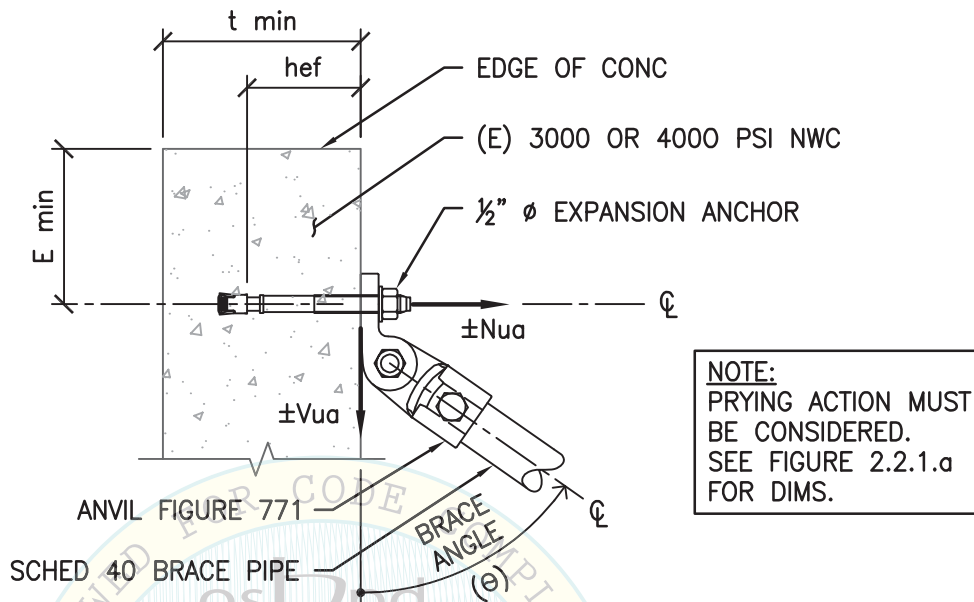

VERT FACE OF WALLS & BMS

FIGURE 2.2.1b - ANCHORING DETAILS FOR 3000 PSI & 4000 PSI NWC

CONC STRENGTH f'c (PSI)	ANCHOR DIA (INCH)	EFFECTIVE EMBED hef (INCH)	MIN CONC EDGE DISTANCE E _{min} (INCH)	MIN SPCG S _{min}	MIN CONC THK t _{min}	TENSION CAPACITY φNn (LBS)	SHEAR CAPACITY φVn (LBS)
3000	1/2	2	6	18	4	1280	1840
3000	1/2	3/4	6	18	6	2620 ¹	2480
4000	1/2	2	6	18	4	1480	2120
4000	1/2	3/4	6	18	6	3030 ²	2860 ³

TABLE 2.2.1 - ANCHORING TO 3000 PSI & 4000 PSI NWC (USE W/ LRFD)
(VALUES ENVELOPE ALL THREE MFR'S EXPANSION ANCHORS)

- ¹ TENSION CAPACITY FOR POWERS IS 1330 LBS.
- ² TENSION CAPACITY FOR POWERS IS 1540 LBS.
- ³ SHEAR CAPACITY FOR POWERS IS 2570 LBS.

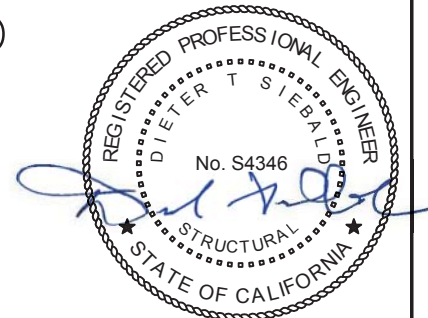

SHEET TITLE: ANCHORAGES TO CONCRETE STRUCTURE
SUPPORTS & ATTACHMENTS



CYS STRUCTURAL ENGINEERS, INC.

2495 NATOMAS PARK DRIVE, SUITE 650
SACRAMENTO, CA 95833

TEL (916) 920-2020
www.cyseng.com

Job No:	14090
Date:	09-22-2016
Page:	24 of 60

SEISMIC SWAY BRACING FOR FIRE PROTECTION SYSTEMS

2.2. SUPPORTS & ATTACHMENTS (CONTINUED)

2.2.2. CONC FILL OVER MTL DECK

2.2.2.1. BRACE ANGLE (Θ) PER NFPA FIGURE 9.3.5.12.1.

2.2.2.2. SEE TABLE 2.2.2 FOR ADDNL ANCHOR INSTALLATION INFO.

2.2.2.3. SEE SECTION 4.1 FOR ADDNL INFO ON ANVIL FIGURE 771 INSTALLATION.

2.2.2.4. INTERACTION OF TENSILE & SHEAR FORCES SHALL BE VERIFIED BY THE CRDP PER THE ICC REPORTS & ACI 318-11 APPENDIX D. SEOR SHALL VERIFY THE SUITABILITY OF THE STRUCTURE FOR DETERMINED LOADS.

2.2.2.5. STRENGTH DESIGN CAPACITIES IN SHEAR & TENSION ARE PROVIDED FOR ANCHORS INSTALLED IN CONC OF MIN COMPRESSIVE STRENGTH AS LISTED IN TABLE 2.2.2 AT THE TIME OF INSTALLATION. FOR ADDNL COMMENTS REGARDING CAPACITIES PROVIDED, SEE SECTION 2.2.1.5.

2.2.1.6. WHEN INSTALLING ANCHORS, AVOID DAMAGING REINF OR PRE-STRESSING STL.

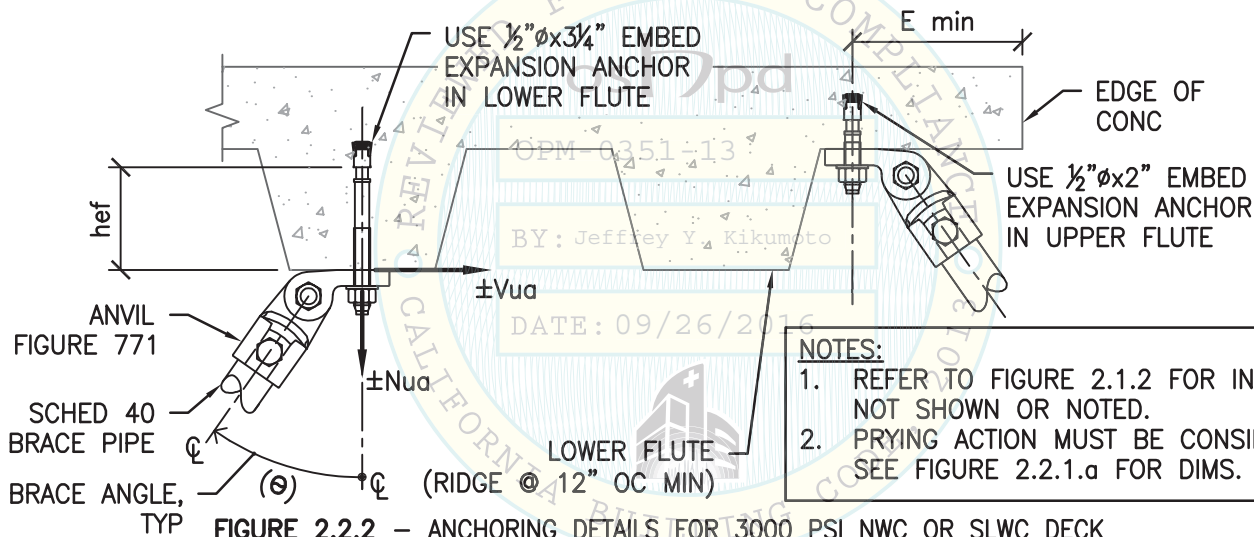

NOTES:
 1. REFER TO FIGURE 2.1.2 FOR INFO NOT SHOWN OR NOTED.
 2. PRYING ACTION MUST BE CONSIDERED. SEE FIGURE 2.2.1.a FOR DIMS.

ANCHOR DIA (INCH)	EFFECTIVE EMBED hef (INCH)	MIN CONC EDGE DISTANCE E _{min} (INCH)	MIN SPCG ¹ S _{min}	TENSION CAPACITY ϕN_n (LBS)	SHEAR CAPACITY ϕV_n (LBS)
1/2	2	6	6 3/4	710	1430
1/2	3/4	6	9 3/4	1270	2450

TABLE 2.2.2 - ANCHORING TO 3000 PSI NWC OR SLWC DECK (USE W/ LRFD)
 (VALUES ENVELOPE ALL THREE MFR'S EXPANSION ANCHORS)

¹ PARALLEL TO FLUTES

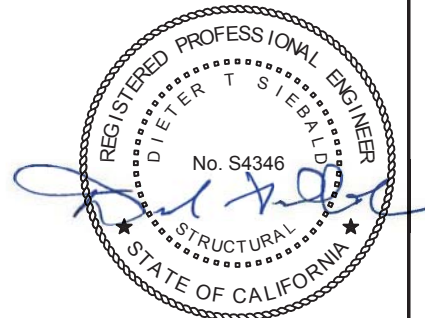

**SHEET TITLE: ANCHORAGES TO CONCRETE STRUCTURE
 SUPPORTS & ATTACHMENTS**

	CYS STRUCTURAL ENGINEERS, INC.	Job No: 14090	
	2495 NATOMAS PARK DRIVE, SUITE 650 SACRAMENTO, CA 95833	TEL (916) 920-2020 www.cyseng.com	Date: 09-22-2016
			Page: 25 of 60

L:\Jobs\14090 Anvil - Fire Sprinkler System OPM-0351-13\ACAD\STRU\S1.dwg Time: Sep 22, 2016 - 02:16pm Login: camachom DimScale: 1 LScale: 4

SEISMIC SWAY BRACING FOR FIRE PROTECTION SYSTEMS

3. ANCHORAGES TO WOOD STRUCTURE:

3.1. SUPPORTS & ATTACHMENTS

3.1.1. MIN WOOD MEMBER THK = 1.5"

3.1.2. ANVIL FIGURE 771 SWAY BRACE SWIVEL ATTACHMENT SHALL BE MOUNTED TO THE MOUNTING BOLT. SEE SECTION 4.1 FOR ANVIL FIGURE 771 INSTALLATION INSTRUCTIONS. BRACE ANGLE (θ) PER NFPA 13, FIGURE 9.3.5.12.1.

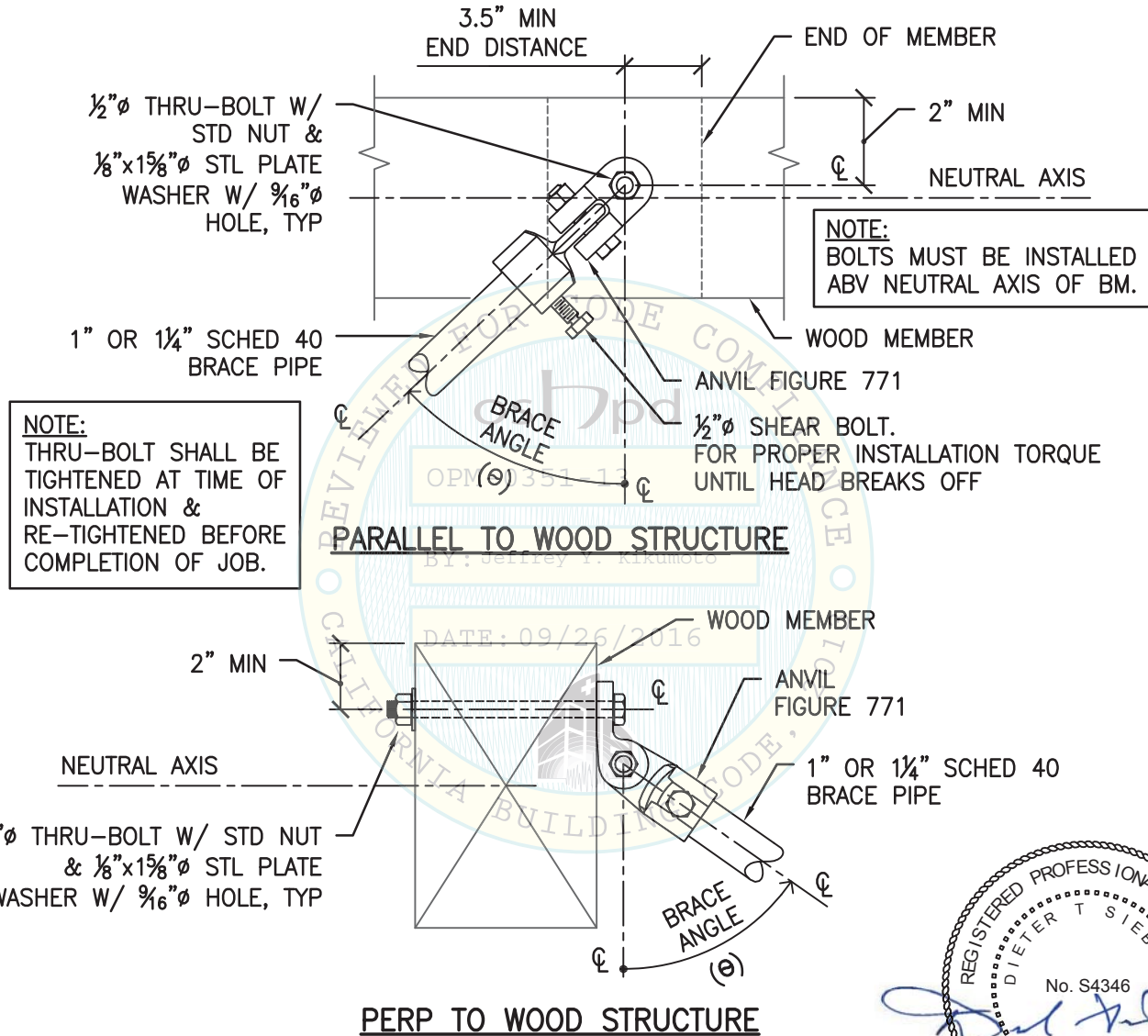
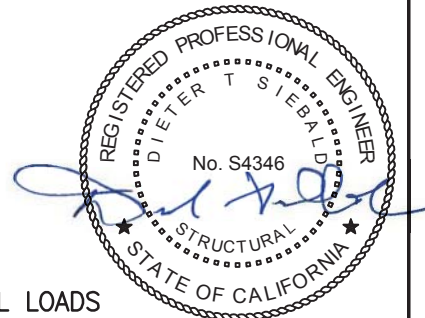

FIGURE 3.1.1 – ANCHORING TO WOOD FOR PERP & PARALLEL LOADS



SHEET TITLE: ANCHORAGES TO WOOD STRUCTURE
SUPPORTS & ATTACHMENTS

 <p>CYS STRUCTURAL ENGINEERS, INC. 2495 NATOMAS PARK DRIVE, SUITE 650 SACRAMENTO, CA 95833</p>	Job No: 14090
	Date: 09-22-2016
	Page: 26 of 60

L:\Jobs\14090 Anvil - Fire Sprinkler System OPM-0351-13\ACAD\STRU\S1.dwg Time:Sep22,2016-02:16pm Login:camachom Dimscale:1 LScale:4

SEISMIC SWAY BRACING FOR FIRE PROTECTION SYSTEMS

3.2. MAX ALLOWABLE LOADS

3.2.1 FOR THE MAX ALLOWABLE HORIZ & VERT LOADS FOR TRANS, LONG, & VERT SEISMIC BRACES USING THE 1/2" DIA MOUNTING BOLT, SEE TABLE 3.2.1.

BOLT DIA (INCH)	SEISMIC APPLICATIONS	BRACE ANGLE ³ (θ) (DEG)	MAX LOAD ^{1, 2, 5} (LBS)
1/2	LONG & TRANS	30 – 44	501
		45 – 59	562
		60 – 90	643
	VERT ⁴	0	436

TABLE 3.2.1 – ANCHORING TO WOOD MAX ALLOWABLE LOADS FOR BRACES PARALLEL TO WOOD STRUCTURE

¹ VALUES PER NDS 2012.

² VALUES BASED ON MIN SPECIFIC GRAVITY, G=0.50 FOR DOUGLAS FIR-LARCH WOOD SPECIES.

³ BRACE PIPE INSTALLATION ANGLES ARE DETERMINED FROM VERT.

⁴ MAX ALLOWABLE VERT SEISMIC LOAD IS AN AXIAL LOAD.

⁵ MAX ALLOWABLE LOADS DO NOT INCLUDE PRYING ACTION. SEOR TO CALCULATE ALLOWABLE LOADS FOR BRACES PARALLEL TO WOOD STRUCTURE INCLUDING PRYING ACTION.

3.2.2 SEOR TO CALCULATE ALLOWABLE LOADS FOR BRACES PERPENDICULAR TO WOOD STRUCTURE INCLUDING PRYING ACTION.

3.3 FASTENER SPECIFICATION

MOUNTING BOLT	1/2"	ASTM A307, GR A (60,000 KSI MIN TENSILE STRENGTH)
WASHER	1/2"	ASTM F844
NUT	1/2"	ASTM A563, GR A



SHEET TITLE: ANCHORAGES TO WOOD STRUCTURE
MAXIMUM ALLOWABLE LOADS & MATERIAL SPECIFICATIONS



CYS STRUCTURAL ENGINEERS, INC.

2495 NATOMAS PARK DRIVE, SUITE 650
SACRAMENTO, CA 95833

TEL (916) 920-2020
www.cyseng.com

Job No:	14090
Date:	09-22-2016
Page:	27 of 60

SEISMIC SWAY BRACING FOR FIRE PROTECTION SYSTEMS

4. ANCHORAGES TO STEEL STRUCTURE

4.1. FIGURE 771 – SWAY BRACE SWIVEL ATTACHMENT

4.1.1. PRODUCT OVERVIEW

- 4.1.1.1. ANVIL'S FIGURE 771 IS A SEISMIC SWIVEL CONNECTOR DESIGNED TO CONNECT BRACE PIPE TO A STRUC MEMBER OR SEISMIC SUPPORT. STRUC MEMBERS & SEISMIC SUPPORTS INCLUDE CONC, WOOD, ANVIL'S FIGURE 772, & ANVIL'S FIGURE 778. SEE SECTION 2.2, SECTION 3.1, SECTION 4.2, & SECTION 4.3 RESPECTIVELY FOR THE RELATED STRUC MEMBER & SEISMIC ATTACHMENT INSTALLATION INSTRUCTIONS.
- 4.1.1.2. ANVIL'S FIGURE 771 MAY BE INSTALLED IN LONG, TRANS, & VERT SEISMIC BRACE ORIENTATIONS.
- 4.1.1.3. REFER TO SECTION 6.2 FOR THE MATERIAL SPECS FOR THE FIGURE 771.

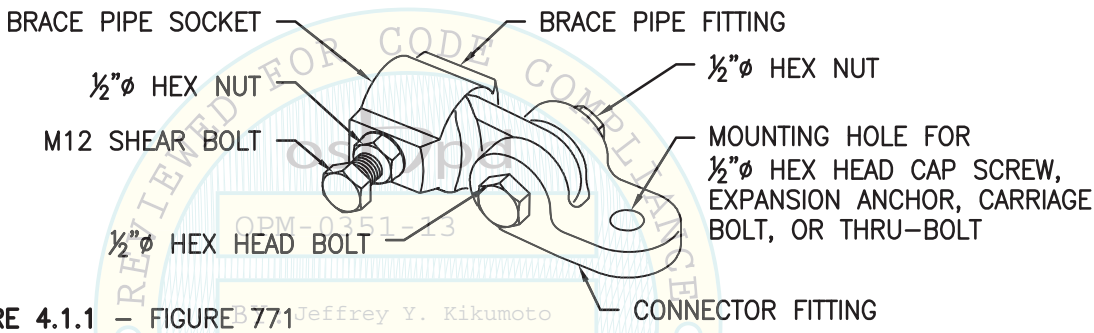
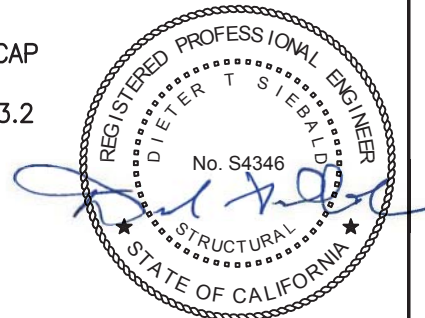

FIGURE 4.1.1 – FIGURE 771 Jeffrey Y. Kikumoto

4.1.2. INSTALLATION INSTRUCTIONS

- 4.1.2.1. INSERT BRACE PIPE INTO BRACE SOCKET UNTIL BRACE PIPE BOTTOMS OUT.
- 4.1.2.2. TORQUE SHEAR BOLT UNTIL BOLT HEAD SHEARS OFF. SEE FIGURE 4.1.3.
- 4.1.2.3. INSERT 1/2 inch diameter hex head cap screw, expansion anchor, carriage bolt, or thru-bolt THRU THE MOUNTING HOLE. SEE FIGURE 4.1.1 FOR MOUNTING HOLE LOCATION.
- 4.1.2.4. FOR TIGHTENING OR TORQUEING OF THE HEX HEAD CAP SCREW, EXPANSION ANCHOR, CARRIAGE BOLT, OR THRU-BOLT, SEE SECTIONS 2.1.2, 3.1, 4.2.2, OR 4.3.2 RESPECTIVELY.



SHEET TITLE: ANCHORAGES TO STEEL STRUCTURE
 FIGURE 771 - SWAY BRACE SWIVEL ATTACHMENT

 CYS STRUCTURAL ENGINEERS, INC. 2495 NATOMAS PARK DRIVE, SUITE 650 SACRAMENTO, CA 95833	TEL (916) 920-2020 www.cyseng.com	Job No: 14090
		Date: 09-22-2016
		Page: 28 of 60

L:\Jobs\14090 Anvil - Fire Sprinkler System OPM-0351-13\ACAD\STRU\S1.dwg Time: Sep 22, 2016 - 02:16pm Login: camachom DimScale: 1 LScale: 4

SEISMIC SWAY BRACING FOR FIRE PROTECTION SYSTEMS

4.1. **FIGURE 771 – SWAY BRACE SWIVEL ATTACHMENT (CONTINUED)**

4.1.2.5 ENSURE BRACE PIPE IS SET TO THE DESIRED BRACE INSTALLATION ANGLE FROM VERT. SEE EXAMPLES IN FIGURE 4.1.2 & FIGURE 4.1.4 FOR INSTALLATION BRACE ANGLE (θ) PER NFPA 13, SECTION 9.

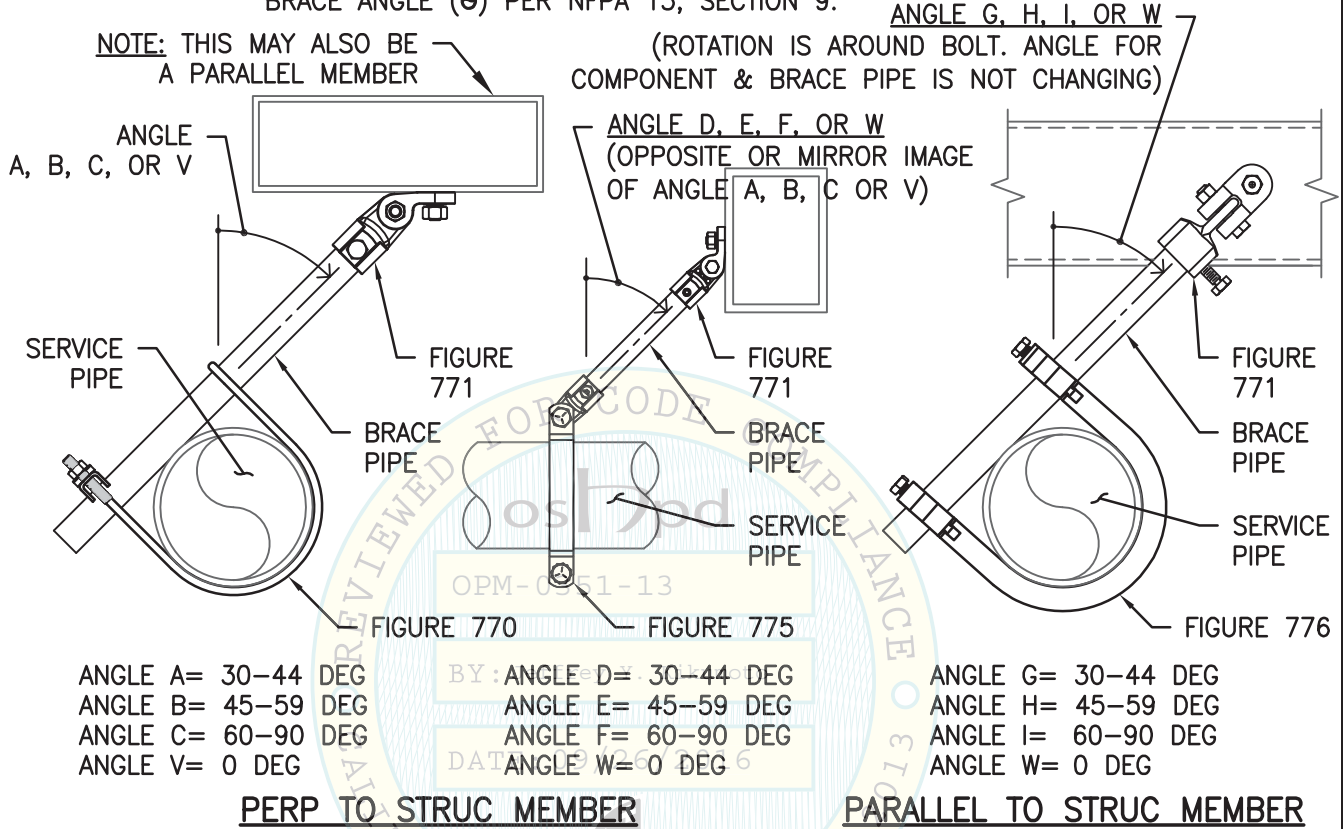
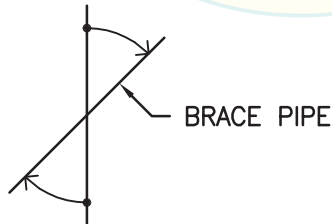

FIGURE 4.1.2 – FIGURE 770, FIGURE 775, & FIGURE 776

NOTE: INSTALLATION BRACE ANGLE IS ALWAYS MEASURED FROM VERT.



THUS ANGLES "A" THROUGH "I" AND "V" & "W" ARE THE SAME AS THE BRACE ANGLE (θ) USED IN THIS OPM.



SHEET TITLE: ANCHORAGES TO STEEL STRUCTURE
FIGURE 771 - SWAY BRACE SWIVEL ATTACHMENT



CYS STRUCTURAL ENGINEERS, INC.

2495 NATOMAS PARK DRIVE, SUITE 650
SACRAMENTO, CA 95833

TEL (916) 920-2020
www.cyseng.com

Job No:	14090
Date:	09-22-2016
Page:	29 of 60

L:\Jobs\14090 Anvil - Fire Sprinkler System OPM-0351-13\ACAD\STRU\S1.dwg Time:Sep22,2016-02:16pm Login:camachom DimScale:1 LScale:4

SEISMIC SWAY BRACING FOR FIRE PROTECTION SYSTEMS

4.1. FIGURE 771 – SWAY BRACE SWIVEL ATTACHMENT (CONTINUED)

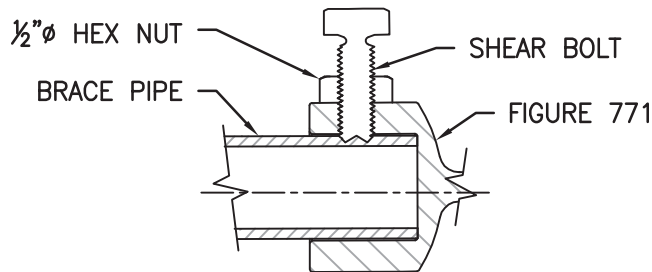

FIGURE 4.1.3 – SHEAR BOLT – BRACE PIPE INTERACTION DETAIL

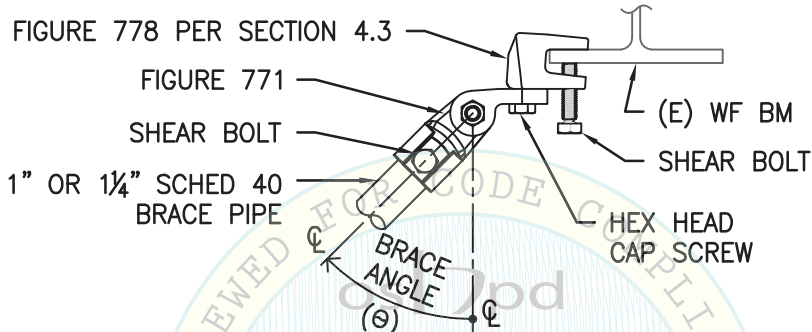

FIGURE 4.1.4 – EXAMPLE OF FIGURE 771 CONNECTED TO FIGURE 778 BM CLAMP

4.1.2.6. FIGURE 778 MAY BE REPLACE W/ FIGURE 772 WHERE WF BM & LOADS ALLOW.

4.1.3. MAX ALLOWABLE LOADS

4.1.3.1. FOR THE MAX ALLOWABLE HORIZ & VERT LOADS FOR TRANS, LONG, & VERT SEISMIC BRACES USING THE FIGURE 771 – SWAY BRACE SWIVEL SUPPORT, SEE TABLE 4.1.1.

NOTES:
 1. PRYING ACTION MUST BE CONSIDERED. SEE FIGURE 2.2.1.a FOR DIMS.
 2. FOR BRACE ANGLE, SEE FIGURE 4.1.2.

BRACE PIPE (NPS)	SEISMIC APPLICATIONS	INSTALLATION ORIENTATIONS	BRACE ANGLE ² (θ) (DEG)	MAX LOAD (LBS)
1 & 1¼	LONG & TRANS	A, D, G	30 – 44	1800
		B, E, H	45 – 59	2540 ⁴
		C, F, I	60 – 90	3110 ⁴
	VSB ³	V, W	0	1800

TABLE 4.1.1 – FIGURE 771 – MAX ALLOWABLE HORIZ & VERT SEISMIC LOADS (ASD)

¹ LOADS DETERMINED FROM FM APPROVAL. SEE SECTION 1.6 FOR ASD/LRFD DESIGN FACTORS.
² BRACE PIPE INSTALLATION ANGLES ARE DETERMINED FROM VERT, SEE FIGURE 4.1.2.
³ MAX ALLOWABLE VSB LOAD IS AN AXIAL LOAD.
⁴ 1800 FOR INSTALLATION ORIENTATIONS H & I.

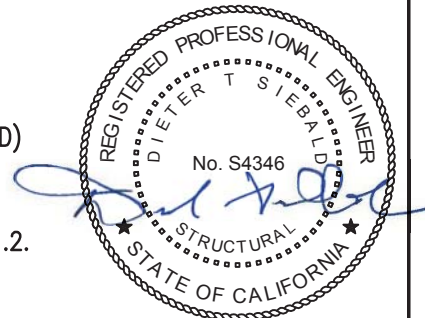

SHEET TITLE: ANCHORAGES TO STEEL STRUCTURE
 FIGURE 771 - SWAY BRACE SWIVEL ATTACHMENT

 CYS STRUCTURAL ENGINEERS, INC. 2495 NATOMAS PARK DRIVE, SUITE 650 SACRAMENTO, CA 95833	TEL (916) 920-2020 www.cyseng.com	Job No: 14090 Date: 09-22-2016 Page: 30 of 60
---	--------------------------------------	---

L:\Jobs\14090 Anvil - Fire Sprinkler System OPM-0351-13\ACAD\STRU\S1.dwg Time:Sep22,2016-02:17pm Login:camachom Dimscale:1 LScale:4

SEISMIC SWAY BRACING FOR FIRE PROTECTION SYSTEMS

4.2. FIGURE 772 – ADJUSTABLE STEEL BEAM ATTACHMENT

4.2.1. PRODUCT OVERVIEW

4.2.1.1. ANVIL'S FIGURE 772 IS A SEISMIC SUPPORT DESIGNED TO RIGIDLY ATTACH TO A WF BEAM & TO ANVIL'S FIGURE 771 (NOT SHOWN HERE IN FIGURE 4.2.1 FOR CLARITY).

4.2.1.2. ANVIL'S FIGURE 772 MAY BE INSTALLED IN LONG, TRANS, & VERT SEISMIC BRACE ORIENTATIONS.

4.2.1.3. REFER TO SECTION 6.3 FOR THE MATERIAL SPECS FOR THE FIGURE 772.

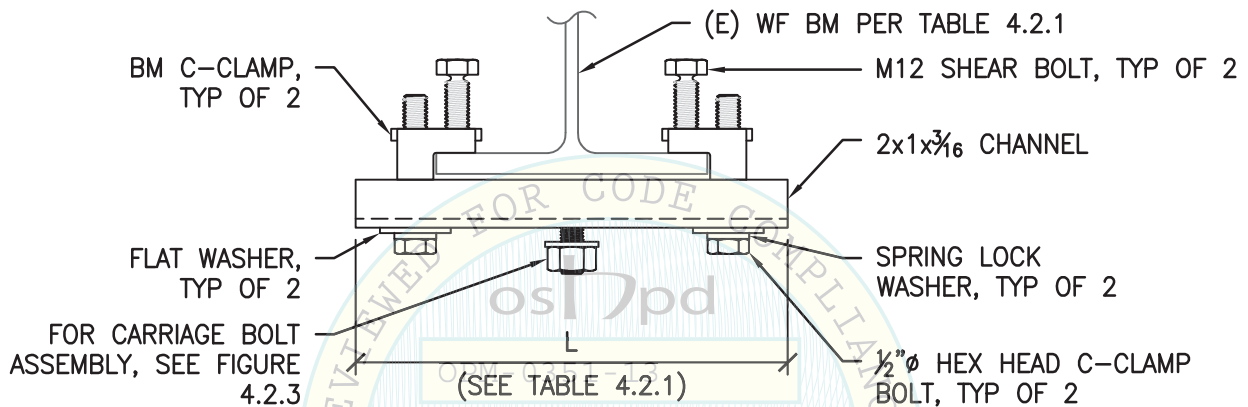

FIGURE 4.2.1 – FIGURE 772 MOUNTING DETAILS

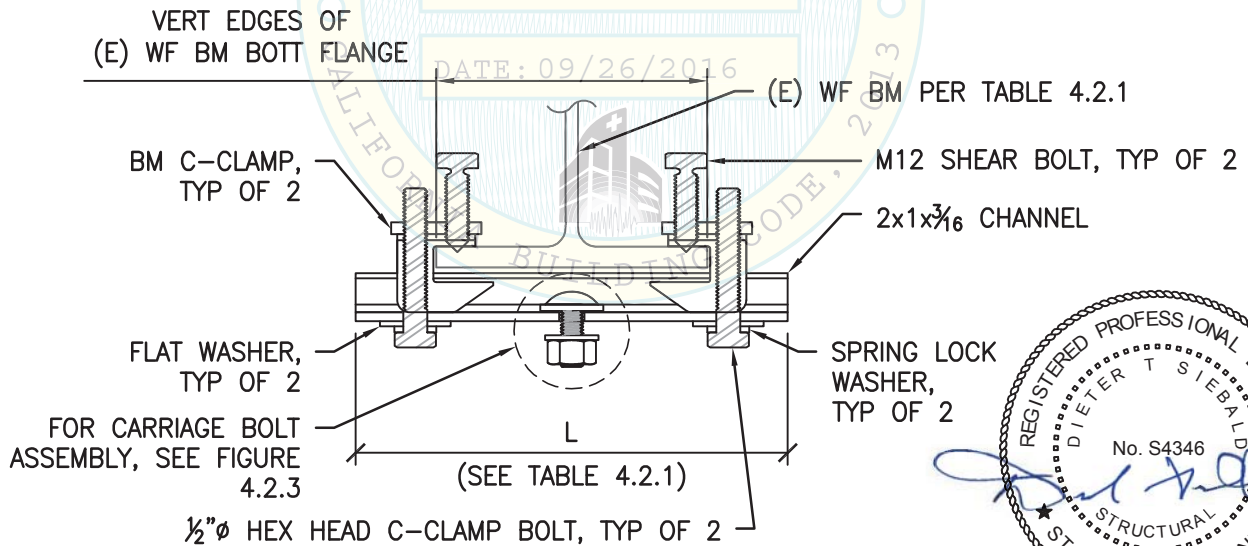

FIGURE 4.2.2 – SECTION VIEW OF FIGURE 772



SHEET TITLE: ANCHORAGES TO STEEL STRUCTURE
 FIGURE 772 - ADJUSTABLE STEEL BEAM ATTACHMENT



CYS STRUCTURAL ENGINEERS, INC.

2495 NATOMAS PARK DRIVE, SUITE 650
 SACRAMENTO, CA 95833

TEL (916) 920-2020
 www.cyseng.com

Job No:	14090
Date:	09-22-2016
Page:	31 of 60

L:\Jobs\14090 Anvil - Fire Sprinkler System OPM-0351-13\ACAD\STRU\S1.dwg Time:Sep22,2016 -02:17pm Login:camachom DimScale:1 LScale:4

SEISMIC SWAY BRACING FOR FIRE PROTECTION SYSTEMS

4.2. FIGURE 772 – ADJUSTABLE STEEL BEAM ATTACHMENT (CONTINUED)

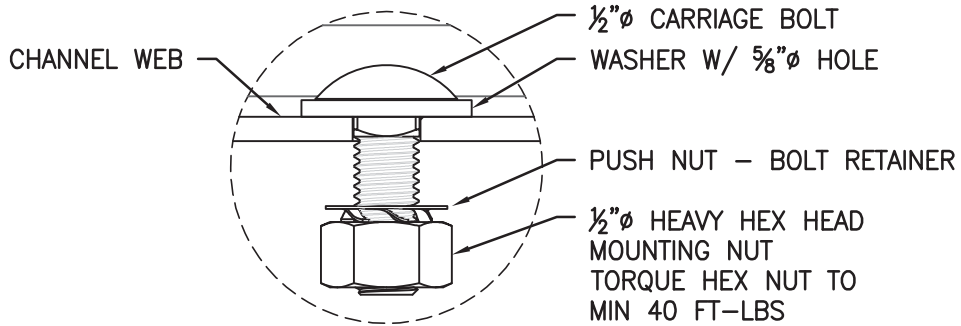

FIGURE 4.2.3 – DETAIL OF CARRIAGE BOLT ASSEMBLY

4.2.2. INSTALLATION INSTRUCTIONS

4.2.2.1. SEE TABLE 4.2.1 & TABLE 4.2.2 TO DETERMINE RECOMMENDED FIGURE 772 SIZE BASED ON (E) WF BM DIMS. MIN FLANGE THK IS 3/8".

4.2.2.2. C-CLAMP BOLTS SHALL BE ADJUSTED ALONG THE 1/2" DIA SLOT IN THE CHANNEL WEB UNTIL THE C-CLAMPS FULLY ENGAGE THE VERT EDGES OF THE (E) WF BM BOTT FLANGE.

4.2.2.3. TORQUE EA M12 SHEAR BOLT UNTIL HEAD SHEARS OFF TO PROPERLY ANCHOR THE BM C-CLAMP TO THE WF BM.

4.2.2.4. TORQUE EA BM C-CLAMP BOLT TO 55 FT-LBS TO SECURE CHANNEL TO THE (E) WF BM.

4.2.2.5. ASSEMBLE CARRIAGE BOLT & CORRESPONDING FLAT WASHER & INSERT THRU THE MOUNTING HOLE IN THE CHANNEL. SEE FIGURE 4.2.3 FOR SECTIONED VIEW.

4.2.2.6. FIGURE 771 SWAY BRACE SWIVEL ATTACHMENT SHALL BE MOUNTED TO FIGURE 772 CARRIAGE BOLT. SEE SECTION 4.1 FOR FIGURE 771 SWIVEL CONNECTOR INSTALLATION INSTRUCTIONS. INSTALLATION BRACE ANGLE (Θ) FROM VERT FOR FIGURE 771 IS PER NFPA 13, SECTION 9.

OPM-0351-13
 BY: Jeffrey Y. Kikumoto
 DATE: 09/26/2016



SHEET TITLE: ANCHORAGES TO STEEL STRUCTURE
 FIGURE 772 - ADJUSTABLE STEEL BEAM ATTACHMENT



CYS STRUCTURAL ENGINEERS, INC.

2495 NATOMAS PARK DRIVE, SUITE 650
 SACRAMENTO, CA 95833

TEL (916) 920-2020
 www.cyseng.com

Job No:	14090
Date:	09-22-2016
Page:	32 of 60

L:\Jobs\14090 Anvil - Fire Sprinkler System OPM-0351-13\ACAD\STRU\S1.dwg Time:Sep22,2016 -02:17pm Login:camachom DimScale:1 LScale:4

SEISMIC SWAY BRACING FOR FIRE PROTECTION SYSTEMS

4.2. FIGURE 772 – ADJUSTABLE STEEL BEAM ATTACHMENT (CONTINUED)

TYPE	A ($\frac{3}{8}$ " – $\frac{3}{4}$ " FLANGE THK)				B ($\frac{3}{4}$ " – $\frac{1}{4}$ " FLANGE THK)		
	9	12	14	17	12	14	17
CHANNEL LENGTH (L) (IN)	9	12	14	17	12	14	17
BM WIDTH RANGE (IN)	4 – 7	7 – 10	9 – 12	12 – 15	7 – 10	9 – 12	12 – 15
BM SIZE	W4x13	W8x35	W10x49	W12x65	W8x67	W10x77	W12x96
	W5x16	W8x40	W10x54	W12x72	W21x93	W10x88	W12x106
	W6x16	W8x48	W10x60	W12x79	W24x94	W10x100	W12x120
	W6x20	W10x39	W10x68	W14x90	–	W10x112	W12x136
	W8x21	W10x45	W12x58	W14x99	–	W14x82	W14x109
	W8x24	W10x49	W12x65	W24x104	–	W16x89	W14x120
	W10x22	W12x40	W14x61	–	–	W16x100	W14x132
	W10x30	W12x45	W14x68	–	–	W18x97	W21x111
	W12x26	W12x50	W16x67	–	–	W18x106	W21x122
	W12x35	W12x53	W16x77	–	–	W18x119	W21x132
	W14x30	W12x58	W18x76	–	–	W24x94	W21x147
	W14x38	W14x43	W18x86	–	–	W27x94	W24x117
	W16x26	W14x48	W24x84	–	–	W27x114	W24x131
	W16x40	W14x53	W27x84	–	–	–	W24x146
	W18x40	W14x61	W27x102	–	–	–	W24x162
	W18x46	W14x68	–	–	–	–	W27x146
	W21x50	W16x45	–	–	–	–	W27x161
	W21x57	W16x50	–	–	–	–	W27x178
	–	W16x57	–	–	–	–	–
	–	W18x50	–	–	–	–	–
	–	W18x55	–	–	–	–	–
	–	W18x60	–	–	–	–	–
–	W18x65	–	–	–	–	–	
–	W21x62	–	–	–	–	–	
–	W21x68	–	–	–	–	–	
–	W24x68	–	–	–	–	–	
–	W24x76	–	–	–	–	–	
–	W27x84	–	–	–	–	–	
–	W27x94	–	–	–	–	–	

TABLE 4.2.1 – FIGURE 772 SIZE CHART



SHEET TITLE: ANCHORAGES TO STEEL STRUCTURE
 FIGURE 772 - ADJUSTABLE STEEL BEAM ATTACHMENT



CYS STRUCTURAL ENGINEERS, INC.

2495 NATOMAS PARK DRIVE, SUITE 650
 SACRAMENTO, CA 95833

TEL (916) 920-2020
 www.cyseng.com

Job No:	14090
Date:	09-22-2016
Page:	33 of 60

L:\Jobs\14090 Anvil - Fire Sprinkler System OPM-0351-13\ACAD\STRU\S1.dwg Time:Sep22,2016-02:17pm Login:camachom Dimstyle:1 LTScale:4

SEISMIC SWAY BRACING FOR FIRE PROTECTION SYSTEMS

4.2. **FIGURE 772 – ADJUSTABLE STEEL BEAM ATTACHMENT (CONTINUED)**

4.2.3. MAX ALLOWABLE LOADS

4.2.3.1. FOR THE MAX ALLOWABLE HORIZ & VERT LOADS FOR TRANS, LONG, & VERT SEISMIC BRACES USING THE FIGURE 771 & FIGURE 772 SUPPORTS PERP & PARALLEL TO WF BM FLANGES, SEE TABLE 4.2.2.

TYPE ³	SEISMIC APPLICATIONS	BRACE ANGLE ² (θ) (DEG)	FLANGE THK (IN)	FLANGE WIDTH (IN)	FIGURE 772 LENGTH (L) (IN)	MAX LOAD PERP TO BM (x)(LBS)	MAX LOAD ¹ PARALLEL TO BM (z)(LBS)
A	LONG & TRANS	30 - 44	3/8 - 3/4	4-7	9	540	470
				7-10	12		
				9-12	14		
				12-15	17		
		45 - 59	3/8 - 3/4	4-7	9	710	480
				7-10	12		
				9-12	14		
				12-15	17		
		60 - 90	3/8 - 3/4	4-7	9	880	580
				7-10	12		
				9-12	14		
				12-15	17		
VSB ⁴	0	3/8 - 3/4	4-7	9	470		
			7-10	12			
			9-12	14			
			12-15	17			
B	LONG & TRANS	30 - 44	3/4 - 1 1/4	7-10	12	470	330
				9-12	14		
				12-15	17		
				7-10	12		
		45 - 59	3/4 - 1 1/4	9-12	14	740	640
				12-15	17		
				7-10	12		
				9-12	14		
		60 - 90	3/4 - 1 1/4	12-15	17	910	790
				7-10	12		
				9-12	14		
				12-15	17		
VSB ⁴	0	3/4 - 1 1/4	7-10	12	330		
			9-12	14			
			12-15	17			
			7-10	12			

TABLE 4.2.2 – FIGURE 772 – MAX ALLOWABLE HORIZ & VERT SEISMIC LOADS (ASD)

¹ LOADS DETERMINED FROM FM APPROVAL. SEE SECTION 1.6 FOR ASD/LRFD DESIGN FACTORS.

² BRACE PIPE INSTALLATION ANGLES ARE DETERMINED FROM VERT.

³ FOR WF BM SIZE CORRESPONDING TO TYPE A OR B, SEE TABLE 4.2.1

⁴ MAX ALLOWABLE VSB LOAD IS AN AXIAL LOAD.

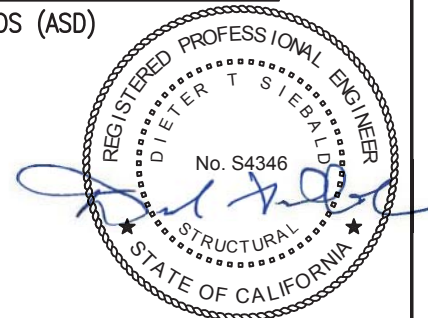

SHEET TITLE: ANCHORAGES TO STEEL STRUCTURE
 FIGURE 772 - ADJUSTABLE STEEL BEAM ATTACHMENT



CYS STRUCTURAL ENGINEERS, INC.

2495 NATOMAS PARK DRIVE, SUITE 650
 SACRAMENTO, CA 95833

TEL (916) 920-2020
 www.cyseng.com

Job No:	14090
Date:	09-22-2016
Page:	34 of 60

L:\Jobs\14090 Anvil - Fire Sprinkler System OPM-0351-13\ACAD\STRU\S1.dwg Time:Sep22,2016-02:17pm Login:camachom DimScale:1 LTScale:4

SEISMIC SWAY BRACING FOR FIRE PROTECTION SYSTEMS

4.3. FIGURE 778 – BAR JOIST BEAM ATTACHMENT

4.3.1. PRODUCT OVERVIEW

- 4.3.1.1. ANVIL'S FIGURE 778 IS A SEISMIC SUPPORT DESIGNED TO RIGIDLY ATTACH TO A WF BM OR BAR JOIST & TO ANVIL'S FIGURE 771.
- 4.3.1.2. ANVIL'S FIGURE 778 MAY BE INSTALLED IN LONG, TRANS, & VERT SEISMIC BRACE ORIENTATIONS.
- 4.3.1.3. REFER TO SECTION 6.6 FOR THE MATERIAL SPECS FOR THE FIGURE 778.

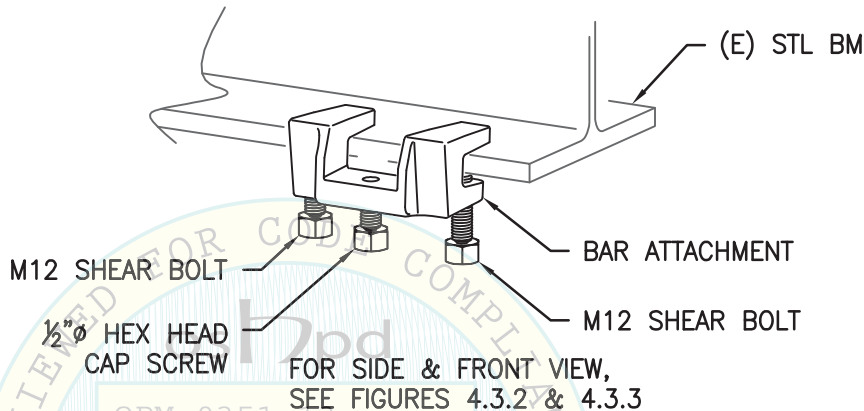
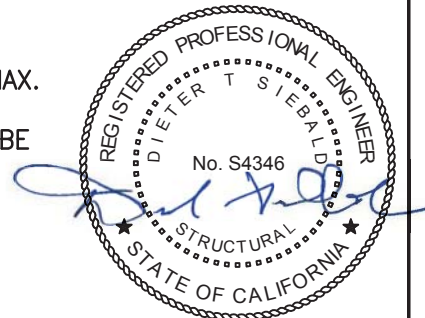

FIGURE 4.3.1 – FIGURE 778

4.3.2. INSTALLATION INSTRUCTIONS

- 4.3.2.1. PLACE THE BAR ATTACHMENT ON THE (E) WF BM OR BAR JOIST. THE FLANGE OF THE WF BM OR THE TOP CHORD OF THE BAR JOIST MUST FULLY ENGAGE W/ THE THROAT OF THE FIGURE 778 BAR JOIST ATTACHMENT. SEE FIGURES 4.3.2 OR 4.3.4.
- 4.3.2.2. TORQUE SHEAR BOLTS EQUALLY & ALTERNATELY UNTIL BOTH BOLT HEADS SHEAR OFF. SEE FIGURES 4.3.3 OR 4.3.5; (2) TYP PER CLAMP.
- 4.3.2.3. FIGURE 771 SWAY BRACE SWIVEL SHALL BE MOUNTED TO FIGURE 778 W/ A HEX HEAD CAP SCREW. SEE SECTION 4.1 FOR FIGURE 771 INSTALLATION INSTRUCTIONS. INSTALLATION BRACE ANGLE (θ) PER NFPA 13, SECTION 9.
- 4.3.2.4. SEE TABLE 4.3.1 FOR COMPATIBLE BM & BAR JOIST FLANGE THICKNESSES. FLANGE THK IS $\frac{1}{8}$ " MIN, $\frac{3}{4}$ " MAX.
- 4.3.2.5. AT BAR JOIST, ATTACHMENT TO STL MEMBER SHALL BE WITHIN 6" ON CHORD PANEL POINT.



SHEET TITLE: ANCHORAGES TO STEEL STRUCTURE
 FIGURE 778 - BAR JOIST BEAM ATTACHMENT

	CYS STRUCTURAL ENGINEERS, INC.	Job No: 14090	
	2495 NATOMAS PARK DRIVE, SUITE 650	TEL (916) 920-2020	Date: 09-22-2016
	SACRAMENTO, CA 95833	www.cyseng.com	Page: 35 of 60

L:\Jobs\14090 Anvil - Fire Sprinkler System OPM-0351-13\ACAD\STRU\S1.dwg Time: Sep 22, 2016 - 02:17pm Login: camachom Dimscale: 1 LScale: 4

SEISMIC SWAY BRACING FOR FIRE PROTECTION SYSTEMS

4.3. FIGURE 778 – BAR JOIST BEAM ATTACHMENT (CONTINUED)

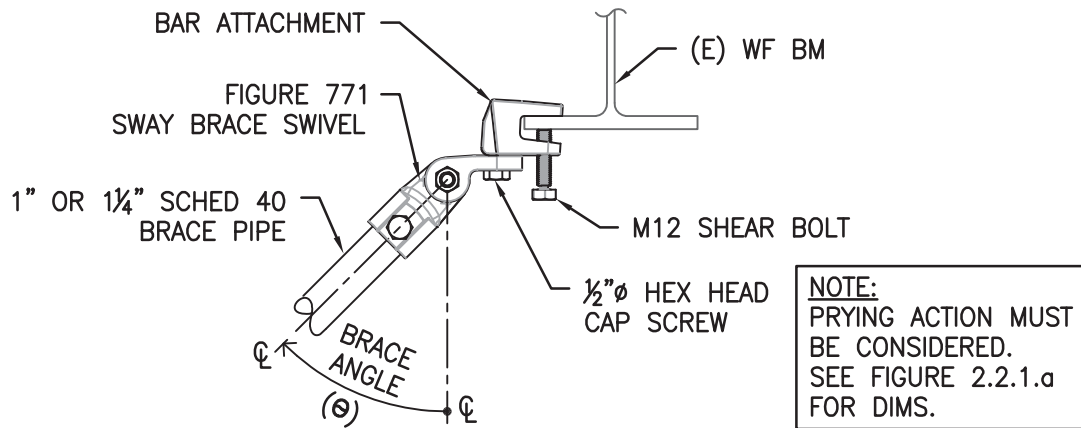

FIGURE 4.3.2 – FIGURE 778 & FIGURE 771 HORIZ ORIENTATION, SIDE VIEW

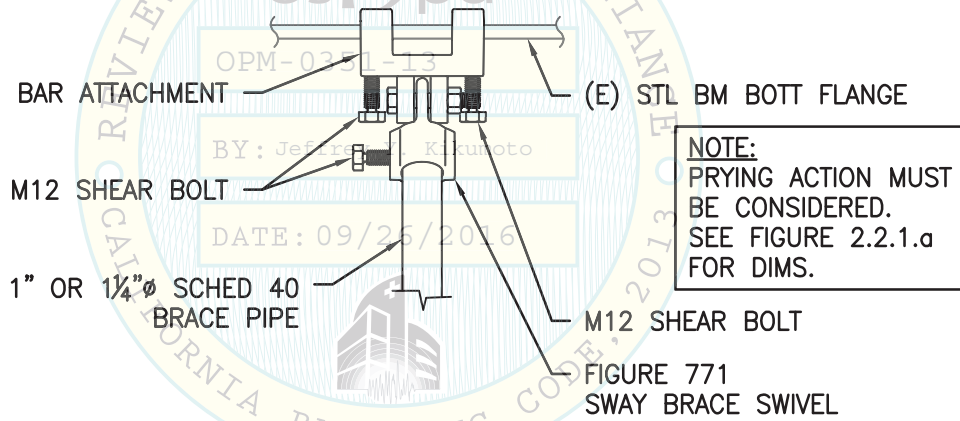

FIGURE 4.3.3 – FIGURE 778 & FIGURE 771 HORIZ ORIENTATION, FRONT VIEW



SHEET TITLE: ANCHORAGES TO STEEL STRUCTURE
FIGURE 778 - BAR JOIST BEAM ATTACHMENT

 <p>CYS STRUCTURAL ENGINEERS, INC. 2495 NATOMAS PARK DRIVE, SUITE 650 SACRAMENTO, CA 95833</p>	TEL (916) 920-2020 www.cyseng.com	Job No: 14090 Date: 09-22-2016 Page: 36 of 60
--	--------------------------------------	---

L:\Jobs\14090 Anvil - Fire Sprinkler System OPM-0351-13\ACAD\STRU\S1.dwg Time: Sep 22, 2016 - 02:17pm Login: camachom Dimscale: 1 LScale: 4

SEISMIC SWAY BRACING FOR FIRE PROTECTION SYSTEMS

4.3. FIGURE 778 – BAR JOIST BEAM ATTACHMENT (CONTINUED)

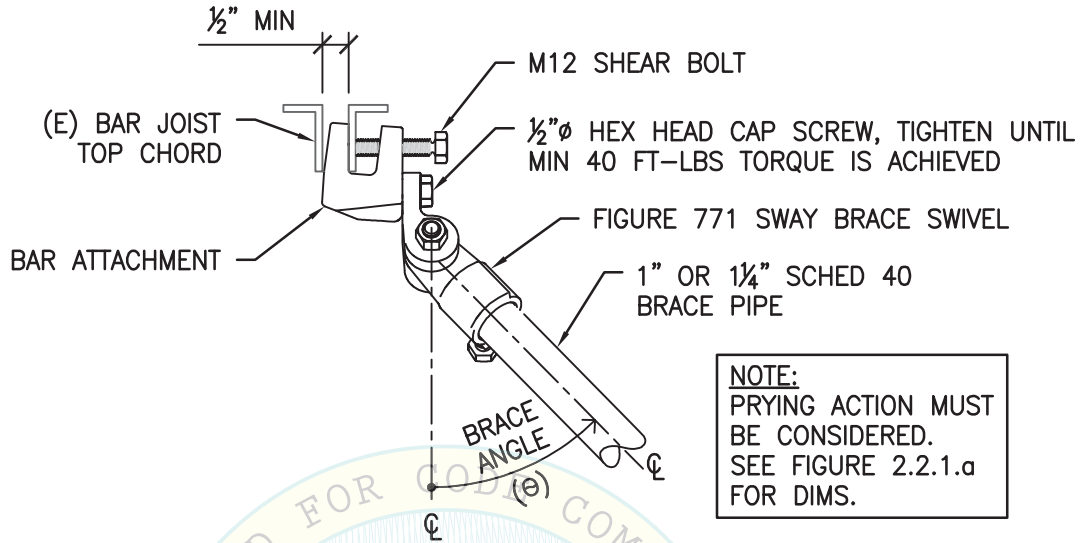

FIGURE 4.3.4 – FIGURE 778 & FIGURE 771 VERT ORIENTATION, SIDE VIEW

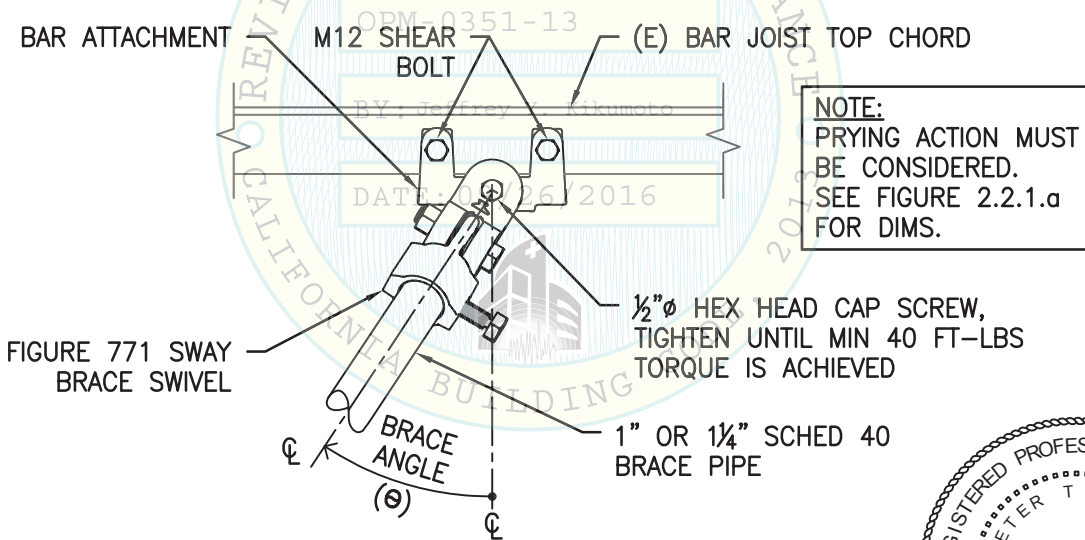

FIGURE 4.3.5 – FIGURE 778 & FIGURE 771 VERT ORIENTATION, FRONT VIEW



SHEET TITLE: ANCHORAGES TO STEEL STRUCTURE
FIGURE 778 - BAR JOIST BEAM ATTACHMENT

 <p>CYS STRUCTURAL ENGINEERS, INC. 2495 NATOMAS PARK DRIVE, SUITE 650 SACRAMENTO, CA 95833</p>	TEL (916) 920-2020	Job No: 14090
	www.cyseng.com	Date: 09-22-2016
		Page: 37 of 60

L:\Jobs\14090 Anvil - Fire Sprinkler System OPM-0351-13\ACAD\STRU\S1.dwg Time:Sep22,2016-02:17pm Login:camachom DimScale:1 L1Scale:4

SEISMIC SWAY BRACING FOR FIRE PROTECTION SYSTEMS

4.3. FIGURE 778 – BAR JOIST BEAM ATTACHMENT (CONTINUED)

4.3.3. MAX ALLOWABLE LOADS

4.3.3.1. FOR THE MAX ALLOWABLE HORIZ & VERT LOADS FOR LONG, TRANS, & VERT SEISMIC BRACES USING THE FIGURE 771 & 778 SUPPORTS PERP & PARALLEL TO BAR JOIST OR WF BM FLANGES, SEE TABLE 4.3.1.

STL STRUCTURE	SEISMIC APPLICATION	BRACE ANGLE ² (θ) (DEG)	FLANGE THK (IN)	MAX LOAD ¹ PERP TO BM (x) (LBS)	MAX LOAD ¹ PARALLEL TO BM (z) (LBS)
BAR JOIST	LONG & TRANS	30 – 44	1/8 – 3/4	1570	1280
		45 – 59		1490	1840
		60 – 90		1040	2210
	VSB ³	0		1280	
WF BM	LONG & TRANS	30 – 44	1/8 – 3/4	1030	870
		45 – 59		2260	1440
		60 – 90		2490	1230
	VSB ³	0		870	

TABLE 4.3.1 – ANVIL FIGURE 778 MAX ALLOWABLE HORIZ & VERT SEISMIC LOADS (ASD)

¹ LOADS DETERMINED FROM FM APPROVAL; SEE SECTION 1.6 FOR ASD/LRFD DESIGN FACTORS.

² BRACE PIPE INSTALLATION ANGLES ARE DETERMINED FROM VERT.

³ MAX ALLOWABLE VSB LOAD IS AN AXIAL LOAD.

BY: Jeffrey Y. Kikumoto

DATE: 09/26/2016

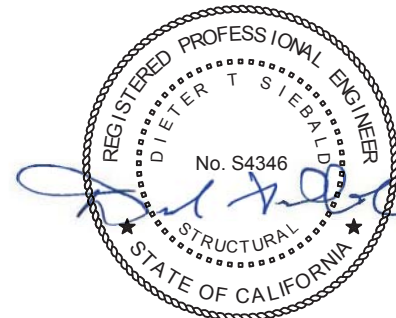

SHEET TITLE: ANCHORAGES TO STEEL STRUCTURE
FIGURE 778 - BAR JOIST BEAM ATTACHMENT



CYS STRUCTURAL ENGINEERS, INC.

2495 NATOMAS PARK DRIVE, SUITE 650
SACRAMENTO, CA 95833

TEL (916) 920-2020
www.cyseng.com

Job No:	14090
Date:	09-22-2016
Page:	38 of 60

L:\Jobs\14090 Anvil - Fire Sprinkler System OPM-0351-13\ACAD\STRU\S1.dwg Time:Sep22,2016--02:17pm Login:camachom Dimstyle:1 LTScale:4

SEISMIC SWAY BRACING FOR FIRE PROTECTION SYSTEMS

5. SEISMIC PIPE CLAMPS

5.1. FIGURE 770 – Q BRACE CLAMP

5.1.1. PRODUCT OVERVIEW

5.1.1.1. ANVIL'S FIGURE 770 – Q BRACE CLAMP IS DESIGNED TO RIGIDLY CONNECT THE BRACE PIPE TO THE SERVICE PIPE.

5.1.1.2. ANVIL'S FIGURE 770 MAY BE INSTALLED IN TRANS & VERT SEISMIC BRACE ORIENTATIONS.

5.1.1.3. REFER TO SECTION 6.1 FOR THE MATERIAL SPECS FOR THE FIGURE 770.

5.1.2. INSTALLATION INSTRUCTIONS

5.1.2.1. PLACE THE $\frac{3}{8}$ " ϕ THRD ROD HOOP OVER THE SERVICE PIPE & SLIDE THE BRACE PIPE THRU THE OPEN ENDS OF THE $\frac{3}{8}$ " ϕ THRD ROD HOOP. THE BRACE PIPE END MUST EXTEND AT LEAST 2" PAST THE CLAMP BAR. SEE FIGURE 5.1.2.

5.1.2.2. ENSURE BRACE PIPE IS SET TO THE DESIRED INSTALLATION BRACE ANGLE. SEE FIGURE 5.1.2. INSTALLATION BRACE ANGLE (θ) FROM VERT IS PER NFPA 13, SECTION 9.

5.1.2.3. TORQUE HEX NUTS EQUALLY & ALTERNATELY TO THE TORQUE LISTED IN TABLE 5.1.1. ENSURE INDICATOR CLIP IS COMPLETELY FLATTENED & THE BRACE PIPE IS TIGHT AGAINST THE SERVICE PIPE.

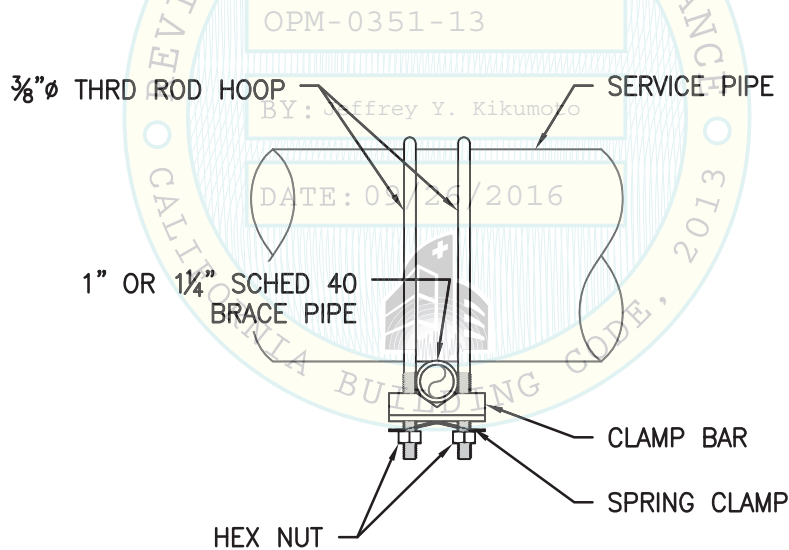

FIGURE 5.1.1 – Q BRACE CLAMP SIDE VIEW



SHEET TITLE: SEISMIC PIPE CLAMPS
FIGURE 770 - Q BRACE CLAMP



CYS STRUCTURAL ENGINEERS, INC.

2495 NATOMAS PARK DRIVE, SUITE 650
SACRAMENTO, CA 95833

TEL (916) 920-2020
www.cyseng.com

Job No:	14090
Date:	09-22-2016
Page:	39 of 60

L:\Jobs\14090 Anvil - Fire Sprinkler System OPM-0351-13\ACAD\STRU\S1.dwg Time: Sep 22, 2016 - 02:17pm Login: camachom Dimscale: 1 LScale: 4

SEISMIC SWAY BRACING FOR FIRE PROTECTION SYSTEMS

5.1. FIGURE 770 – Q BRACE CLAMP (CONTINUED)

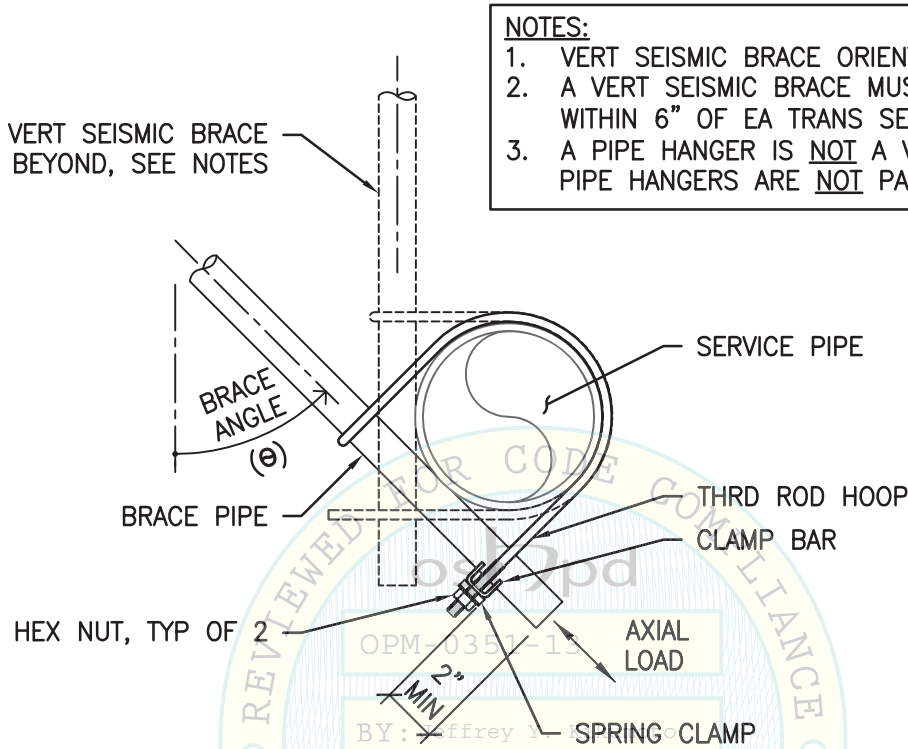

- NOTES:**
1. VERT SEISMIC BRACE ORIENTATION SIM.
 2. A VERT SEISMIC BRACE MUST BE INSTALLED WITHIN 6" OF EA TRANS SEISMIC BRACE.
 3. A PIPE HANGER IS NOT A VERT SEISMIC BRACE. PIPE HANGERS ARE NOT PART OF THIS OPM.

FIGURE 5.1.2 – TRANS & VERT SEISMIC BRACE ORIENTATION
 OPM-0351-13
 BY: Jeffrey Kikumoto
 DATE: 09/26/2016

FIGURE 770 – Q BRACE CLAMP SIZE	INSTALLATION TORQUE (FT/LBS)
1" – 3"	14
4" – 5"	17
6"	20

TABLE 5.1.1 – FIGURE 770 – Q BRACE CLAMP REQ INSTALLATION TORQUE



SHEET TITLE: SEISMIC PIPE CLAMPS
 FIGURE 770 - Q BRACE CLAMP

 <p>CYS STRUCTURAL ENGINEERS, INC. 2495 NATOMAS PARK DRIVE, SUITE 650 SACRAMENTO, CA 95833</p>	TEL (916) 920-2020 www.cyseng.com	Job No: 14090 Date: 09-22-2016 Page: 40 of 60
--	--------------------------------------	---

L:\Jobs\14090 Anvil - Fire Sprinkler System OPM-0351-13\ACAD\STRU\S1.dwg Time: Sep 22, 2016 - 02:17pm Login: camachom DimScale: 1 L1Scale: 4

SEISMIC SWAY BRACING FOR FIRE PROTECTION SYSTEMS

5.1. FIGURE 770 – Q BRACE CLAMP (CONTINUED)

5.1.3. MAX ALLOWABLE HORIZ & VERT SEISMIC LOADS

SERVICE PIPE (NPS)	BRACE PIPE (NPS)	SEISMIC APPLICATIONS	BRACE ANGLE ³ (θ) (DEG)	MAX LOAD ¹ SCHED 10 & UP (LBS)	MAX LOAD ^{1,2} LW (LBS)
1	1, 1¼	TRANS	30 – 44	1110	250
			45 – 59	1570	360
			60 – 90	1930	440
		VSB ⁴	0	1110	250
1¼, 1½, 2, 2½, 3	1, 1¼	TRANS	30 – 44	570	250
			45 – 59	810	360
			60 – 90	1000	440
		VSB ⁴	0	570	250
4, 5	1, 1¼	TRANS	30 – 44	760	410
			45 – 59	1070	590
			60 – 90	1320	720
		VSB ⁴	0	760	410
6	1, 1¼	TRANS	30 – 44	770	450
			45 – 59	1090	630
			60 – 90	1340	780
		VSB ⁴	0	770	450

TABLE 5.1.2 – FIGURE 770 MAX ALLOWABLE HORIZ & VERT SEISMIC LOADS (ASD)

- ¹ LOADS DETERMINED FROM FM APPROVAL; SEE SECTION 1.6 FOR ASD/LRFD DESIGN FACTORS.
- ² SEE SECTION 1.7 FOR APPROVED LW PIPE.
- ³ BRACE PIPE INSTALLATION ANGLES ARE DETERMINED FROM VERT.
- ⁴ MAX ALLOWABLE VSB LOAD IS AN AXIAL LOAD.



SHEET TITLE: SEISMIC PIPE CLAMPS
FIGURE 770 - Q BRACE CLAMP

 CYS STRUCTURAL ENGINEERS, INC. 2495 NATOMAS PARK DRIVE, SUITE 650 SACRAMENTO, CA 95833	TEL (916) 920-2020 www.cyseng.com	Job No: 14090 Date: 09-22-2016 Page: 41 of 60
---	--------------------------------------	---

L:\Jobs\14090 Anvil - Fire Sprinkler System OPM-0351-13\ACAD\STRU\S1.dwg Time:Sep22,2016--02:17pm Login:camachom Dimstyle:1 LTScale:4

SEISMIC SWAY BRACING FOR FIRE PROTECTION SYSTEMS

5.2. FIGURE 775 – LATERAL/LONGITUDINAL BRACE CLAMP

5.2.1. PRODUCT OVERVIEW

- 5.2.1.1. ANVIL'S FIGURE 775 – LATERAL/LONG BRACE CLAMP IS DESIGNED TO RIGIDLY CONNECT THE BRACE PIPE TO THE SERVICE PIPE.
- 5.2.1.2. ANVIL'S FIGURE 775 – MAY BE INSTALLED IN TRANS, LONG, & VERT SEISMIC BRACE ORIENTATIONS.
- 5.2.1.3. REFER TO SECTION 6.4 FOR THE MATERIAL SPECS FOR THE FIGURE 775.

5.2.2. INSTALLATION INSTRUCTIONS

- 5.2.2.1. POSITION PIPE CLAMP AT DESIRED LOCATION ON THE SERVICE PIPE & HAND TIGHTEN THE HEX BOLTS. ENSURE THE SPACER & THE BRACE PIPE CONNECTOR ARE POSITIONED ON THE BOLT BETWEEN THE PIPE CLAMP EARS.
- 5.2.2.2. INSERT BRACE PIPE INTO THE SOCKET OF THE BRACE PIPE CONNECTOR UNTIL BRACE PIPE BOTTOMS OUT. SEE FIGURE 5.2.2.
- 5.2.2.3. TIGHTEN SHEAR BOLT, AT THE BRACE PIPE CONNECTOR, UNTIL THE BOLT HEAD BREAKS OFF.
- 5.2.2.4. ENSURE BRACE PIPE IS SET TO THE DESIRED INSTALLATION BRACE ANGLE. SEE FIGURES 5.2.1 & 5.2.3. INSTALLATION BRACE ANGLE (θ) FROM VERT IS PER NFPA 13, SECTION 9.0351-13
- 5.2.2.5. TIGHTEN HEX BOLTS & HEX NUTS EQUALLY & ALTERNATELY UNTIL MTL-TO-MTL CONTACT IS ACHIEVED W/ THE TORQUE VALUES LISTED IN TABLE 5.2.1.

DATE: 09/26/2016

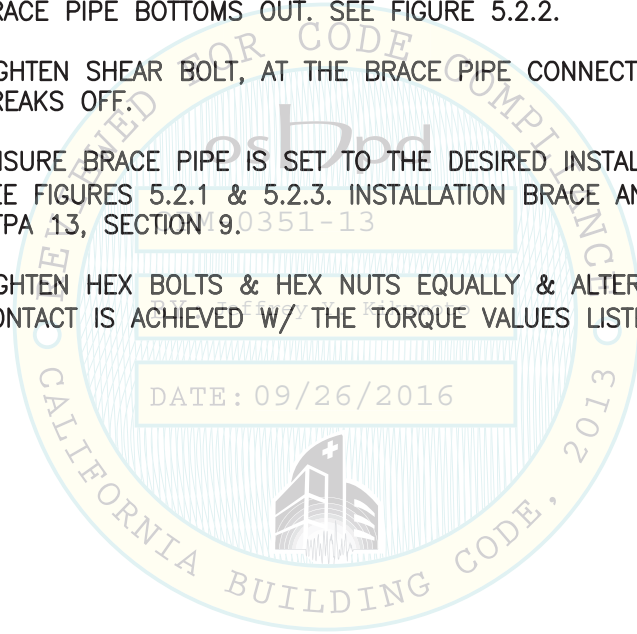

SHEET TITLE: SEISMIC PIPE CLAMPS
 FIGURE 775 - LATERAL / LONGITUDINAL BRACE CLAMP



CYS STRUCTURAL ENGINEERS, INC.

2495 NATOMAS PARK DRIVE, SUITE 650
 SACRAMENTO, CA 95833

TEL (916) 920-2020
 www.cyseng.com

Job No:	14090
Date:	09-22-2016
Page:	42 of 60

L:\Jobs\14090 Anvil - Fire Sprinkler System OPM-0351-13\ACAD\STRU\S1.dwg Time: Sep 22, 2016 - 02:17pm Login: camachom DimScale: 1 LTScale: 4

SEISMIC SWAY BRACING FOR FIRE PROTECTION SYSTEMS

5.2. FIGURE 775 – LATERAL/LONGITUDINAL BRACE CLAMP (CONTINUED)

NOTES:

1. VERT SEISMIC BRACE ORIENTATION SIM.
2. A VERT SEISMIC BRACE MUST BE INSTALLED WITHIN 6" OF EA TRANS SEISMIC BRACE.
3. A PIPE HANGER IS NOT A VERT SEISMIC BRACE. PIPE HANGERS ARE NOT PART OF THIS OPM.

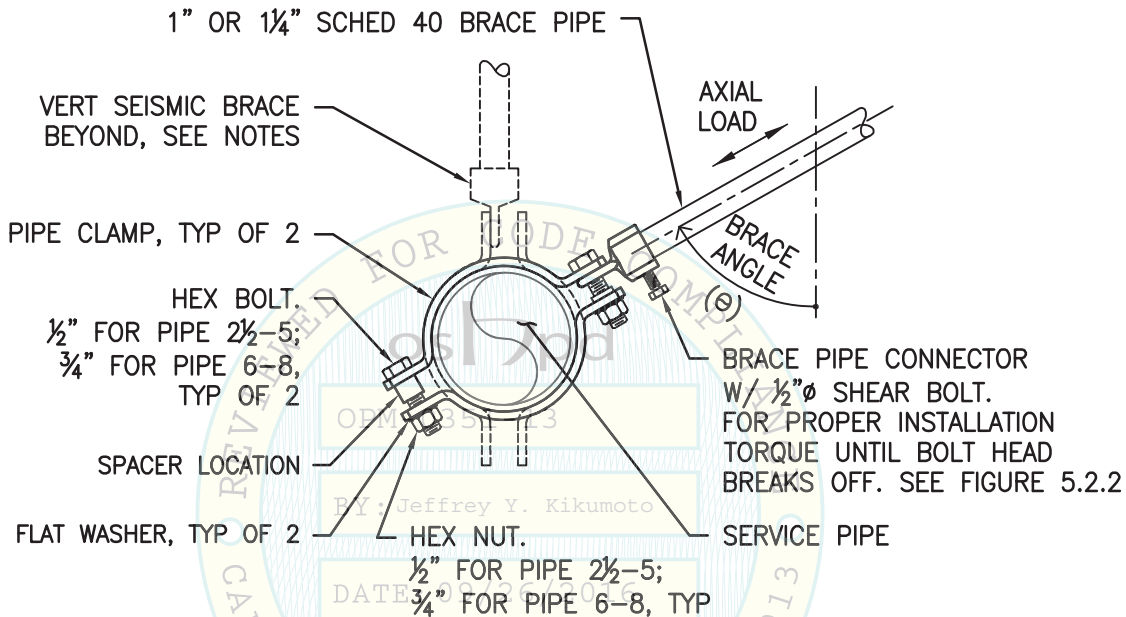

FIGURE 5.2.1 – TRANS & VERT SEISMIC BRACE ORIENTATION

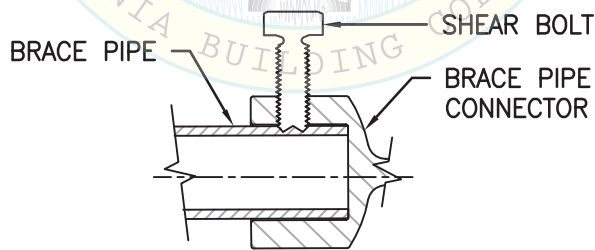

FIGURE 5.2.2 – SHEAR BOLT-BRACE PIPE INTERACTION DETAIL



SHEET TITLE: SEISMIC PIPE CLAMPS
 FIGURE 775 - LATERAL / LONGITUDINAL BRACE CLAMP



CYS STRUCTURAL ENGINEERS, INC.

2495 NATOMAS PARK DRIVE, SUITE 650
 SACRAMENTO, CA 95833

TEL (916) 920-2020
 www.cyseng.com

Job No:	14090
Date:	09-22-2016
Page:	43 of 60

L:\Jobs\14090 Anvil - Fire Sprinkler System OPM-0351-13\ACAD\STRU\S1.dwg Time:Sep22,2016-02:18pm Login:camachom DimScale:1 LScale:4

SEISMIC SWAY BRACING FOR FIRE PROTECTION SYSTEMS

5.2. FIGURE 775 – LATERAL/LONGITUDINAL BRACE CLAMP (CONTINUED)

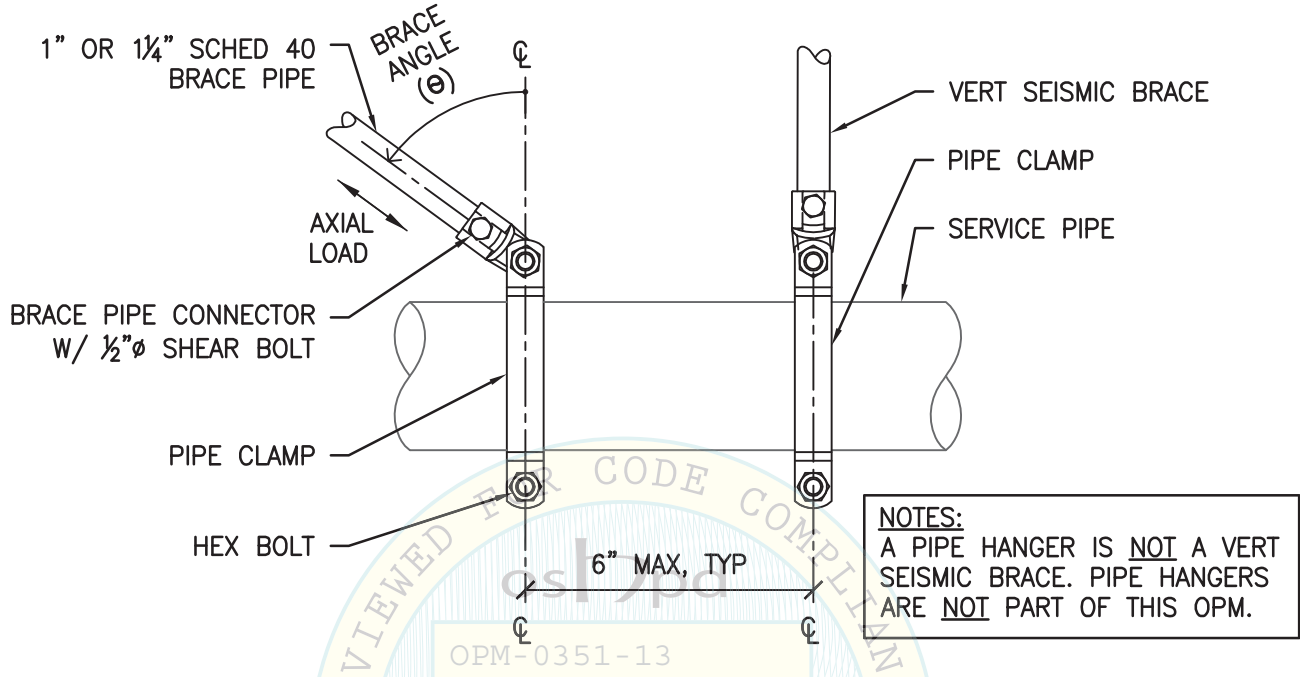

FIGURE 5.2.3 – LONG & VERT SEISMIC BRACE ORIENTATION

FIGURE 775 BRACE CLAMP SIZE (IN)	INSTALLATION TORQUE (FT/LBS)
2½ – 3	80
4 – 5	100
6	120
8	140

TABLE 5.2.1 – FIGURE 775 BRACE CLAMP REQ INSTALLATION TORQUE



SHEET TITLE: SEISMIC PIPE CLAMPS
 FIGURE 775 - LATERAL / LONGITUDINAL BRACE CLAMP

 <p>CYS STRUCTURAL ENGINEERS, INC. 2495 NATOMAS PARK DRIVE, SUITE 650 SACRAMENTO, CA 95833</p>	TEL (916) 920-2020 www.cyseng.com	Job No: 14090
		Date: 09-22-2016
		Page: 44 of 60

L:\Jobs\14090 Anvil - Fire Sprinkler System OPM-0351-13\ACAD\STRU\S1.dwg Time:Sep22,2016-02:18pm Login:camachom DimScale:1 L1Scale:4

SEISMIC SWAY BRACING FOR FIRE PROTECTION SYSTEMS

5.2. FIGURE 775 – LATERAL/LONGITUDINAL BRACE CLAMP (CONTINUED)

5.2.3. MAX ALLOWABLE HORIZ & VERT SEISMIC LOADS

SERVICE PIPE (NPS)	BRACE PIPE (NPS)	SEISMIC APPLICATIONS	BRACE ANGLE ³ (θ) (DEG)	MAX LOAD ¹ SCHED 10 & UP (LBS)	MAX LOAD ^{1, 2} LW (LBS)
2½	1, ¼	LONG & TRANS	30 – 44	1370	1570
			45 – 59	2150	2220
			60 – 90	2390	1690
		VSB ⁴	0	1370	1570
3	1, ¼	LONG & TRANS	30 – 44	1370	1570
			45 – 59	2150	2220
			60 – 90	2390	1690
		VSB ⁴	0	1370	1570
4	1, ¼	LONG & TRANS	30 – 44	1280	1520
			45 – 59	1810	1060
			60 – 90	1680	910
		VSB ⁴	0	1280	1520
5	1, ¼	LONG & TRANS	30 – 44	1370	1570
			45 – 59	2150	2220
			60 – 90	2390	1690
		VSB ⁴	0	1370	1570
6	1, ¼	LONG & TRANS	30 – 44	1520	1570
			45 – 59	2150	2220
			60 – 90	2570	910
		VSB ⁴	0	1520	1570
8	1, ¼	LONG & TRANS	30 – 44	1570	–
			45 – 59	2200	–
			60 – 90	2720	–
		VSB ⁴	0	1570	–

TABLE 5.2.2 – FIGURE 775 MAX ALLOWABLE HORIZ & VERT SEISMIC LOADS (ASD)

¹ LOADS DETERMINED FROM FM APPROVAL; SEE SECTION 1.6 FOR ASD/LRFD DESIGN FACTORS.

² SEE SECTION 1.7 FOR APPROVED LW PIPE.

³ BRACE PIPE INSTALLATION ANGLES ARE DETERMINED FROM VERT.

⁴ MAX ALLOWABLE VSB LOAD IS AN AXIAL LOAD.



SHEET TITLE: SEISMIC PIPE CLAMPS
 FIGURE 775 - LATERAL / LONGITUDINAL BRACE CLAMP



CYS STRUCTURAL ENGINEERS, INC.

2495 NATOMAS PARK DRIVE, SUITE 650
 SACRAMENTO, CA 95833

TEL (916) 920-2020
 www.cyseng.com

Job No:	14090
Date:	09-22-2016
Page:	45 of 60

L:\Jobs\14090 Anvil - Fire Sprinkler System OPM-0351-13\ACAD\STRU\S1.dwg Time:Sep22,2016-02:18pm Login:camachom DimScale:1 L1Scale:4

SEISMIC SWAY BRACING FOR FIRE PROTECTION SYSTEMS

5.3. FIGURE 776 – BRACE CLAMP

5.3.1. PRODUCT OVERVIEW

5.3.1.1. ANVIL'S FIGURE 776 – BRACE CLAMP IS DESIGNED TO RIGIDLY CONNECT THE BRACE PIPE TO THE SERVICE PIPE.

5.3.1.2. ANVIL'S FIGURE 776 MAY BE INSTALLED IN TRANS & VERT SEISMIC BRACE ORIENTATIONS.

5.3.1.3. REFER TO SECTION 6.5 FOR THE MATERIAL SPECS FOR THE FIGURE 776.

5.3.2. INSTALLATION INSTRUCTIONS

5.3.2.1. POSITION PIPE CLAMP HOOP SECTION AT THE DESIRED LOCATION ON THE SERVICE PIPE BY SLIDING THE HOOP OVER THE SERVICE PIPE.

5.3.2.2. SLIDE BRACE PIPE THRU THE STIRRUPS & ENSURE BRACE PIPE IS SET TO THE DESIRED INSTALLATION BRACE ANGLE. SEE FIGURE 5.3.1. INSTALLATION BRACE ANGLE FROM VERT IS PER (θ) NFPA 13, SECTION 9.

5.3.2.3. BRACE PIPE MUST EXTEND 2" MIN PAST THE END OF THE RETAINER CLIP.

5.3.2.4. TIGHTEN HEX HEAD SET SCREW UNTIL HEAD BOTTOMS OUT ON STIRRUP SURFACE.

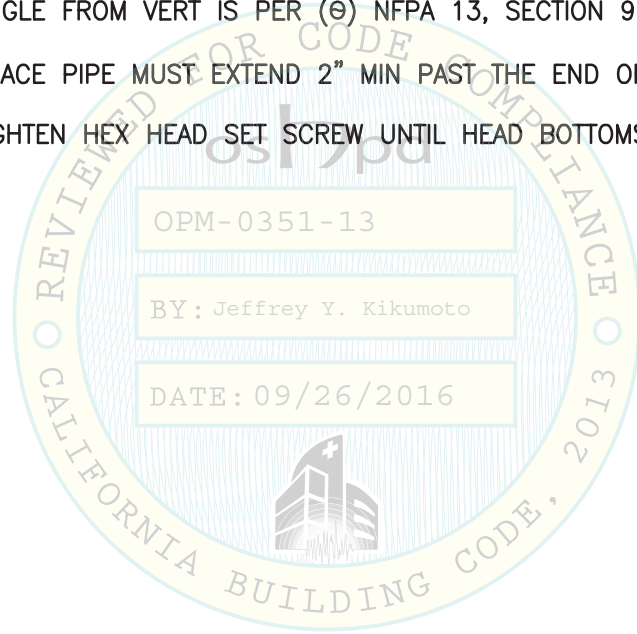

OPM-0351-13
BY: Jeffrey Y. Kikumoto
DATE: 09/26/2016



L:\Jobs14\14090 Anvil - Fire Sprinkler System OPM-0351-13\ACAD\STRU\S1.dwg Time:Sep22,2016--02:18pm Login:camachom Dimscale:1 LTScale:4

SHEET TITLE: SEISMIC PIPE CLAMPS
FIGURE 776 - BRACE CLAMP

 CYS STRUCTURAL ENGINEERS, INC. 2495 NATOMAS PARK DRIVE, SUITE 650 SACRAMENTO, CA 95833	TEL (916) 920-2020 www.cyseng.com	Job No: 14090
		Date: 09-22-2016
		Page: 46 of 60

SEISMIC SWAY BRACING FOR FIRE PROTECTION SYSTEMS

5.3. FIGURE 776 – BRACE CLAMP (CONTINUED)

NOTES:

1. VERT SEISMIC BRACE ORIENTATION SIM.
2. A VERT SEISMIC BRACE MUST BE INSTALLED WITHIN 6" OF EA TRANS SEISMIC BRACE.
3. A PIPE HANGER IS NOT A VERT SEISMIC BRACE. PIPE HANGERS ARE NOT PART OF THIS OPM.

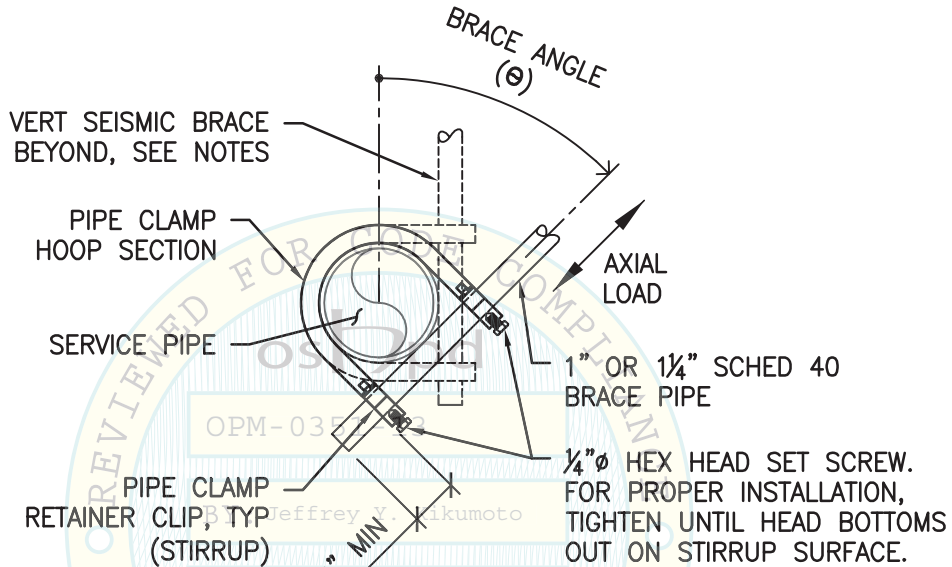
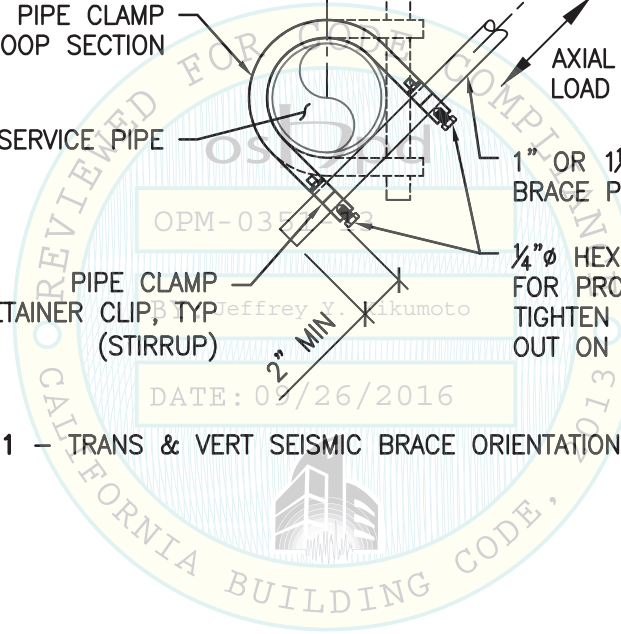

FIGURE 5.3.1 – TRANS & VERT SEISMIC BRACE ORIENTATION



SHEET TITLE: SEISMIC PIPE CLAMPS
 FIGURE 776 - BRACE CLAMP



CYS STRUCTURAL ENGINEERS, INC.

2495 NATOMAS PARK DRIVE, SUITE 650
 SACRAMENTO, CA 95833

TEL (916) 920-2020
 www.cyseng.com

Job No:	14090
Date:	09-22-2016
Page:	47 of 60

L:\Jobs\14\14090 Anvil - Fire Sprinkler System OPM-0351-13\ACAD\STRU\S1.dwg Time: Sep 22, 2016 - 02:18pm Login: camachom DimScale: 1 LTScale: 4

SEISMIC SWAY BRACING FOR FIRE PROTECTION SYSTEMS

5.3. FIGURE 776 – BRACE CLAMP (CONTINUED)

5.3.3. MAX ALLOWABLE HORIZ & VERT SEISMIC LOADS

SERVICE PIPE (NPS)	BRACE PIPE (NPS)	SEISMIC APPLICATIONS	BRACE ANGLE ³ (θ) (DEG)	MAX LOAD ¹ SCHED 10 & UP (LBS)	MAX LOAD ^{1, 2} LW (LBS)
2½	1, ¼	TRANS	30 – 44	620	600
			45 – 59	880	850
			60 – 90	1080	1040
		VSB ⁴	0	620	600
3	1, ¼	TRANS	30 – 44	620	520
			45 – 59	880	740
			60 – 90	1080	910
		VSB ⁴	0	620	520
4	1, ¼	TRANS	30 – 44	690	520
			45 – 59	980	740
			60 – 90	1200	910
		VSB ⁴	0	690	520
5	1, ¼	TRANS	30 – 44	670	520
			45 – 59	940	740
			60 – 90	1160	910
		VSB ⁴	0	670	520
6	1, ¼	TRANS	30 – 44	670	560
			45 – 59	940	790
			60 – 90	1160	970
		VSB ⁴	0	670	560
8	1, ¼	TRANS	30 – 44	540	–
			45 – 59	770	–
			60 – 90	940	–
		VSB ⁴	0	540	–

TABLE 5.3.1 – FIGURE 776 MAX ALLOWABLE HORIZ & VERT SEISMIC LOADS (ASD)

¹ LOADS DETERMINED FROM FM APPROVAL; SEE SECTION 1.6 FOR ASD/LRFD DESIGN FACTORS.

² SEE SECTION 1.7 FOR APPROVED LIGHTWALL (LW) PIPE.

³ BRACE PIPE INSTALLATION ANGLES ARE DETERMINED FROM VERT.

⁴ MAX ALLOWABLE VSB LOAD IS AN AXIAL LOAD.

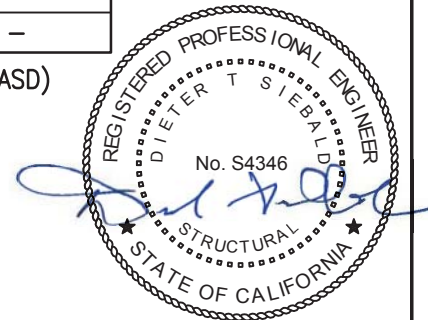

SHEET TITLE: SEISMIC PIPE CLAMPS
FIGURE 776 - BRACE CLAMP



CYS STRUCTURAL ENGINEERS, INC.

2495 NATOMAS PARK DRIVE, SUITE 650
SACRAMENTO, CA 95833

TEL (916) 920-2020
www.cyseng.com

Job No: 14090
Date: 09-22-2016
Page: 48 of 60

L:\Jobs\14090 Anvil - Fire Sprinkler System OPM-0351-13\ACAD\STRU\S1.dwg Time:Sep22,2016-02:18pm Login:camachom Dimstyle:1 LTScale:4

SEISMIC SWAY BRACING FOR FIRE PROTECTION SYSTEMS

6. MATERIAL SPECIFICATIONS

6.1. FIGURE 770 - Q BRACE CLAMP
CLAMP BAR

ASTM A1011, CS, TYPE A, B, OR C

SPRING CLAMP

AISI/SAE 1050 (OR EQUAL)

THREADED ROD, 3/8"-16 UNC-2A

AISI 1006-1015 OR ASTM A36

HEX NUT, 3/8"-16 UNC-2B

ASTM A563, GR A

6.2. FIGURE 771 - SWAY BRACE SWIVEL ATTACHMENT

CONNECTOR FITTING

DUCTILE IRON, ASTM A536, GR 65-45-12

BRACE PIPE FITTING

DUCTILE IRON, ASTM A536, GR 65-45-12

HEX HEAD CAP SCREW,
1/2"-13 UNC-2Ax2 1/4"

CARBON STEEL, ASTM A307, GR A

HEX HEAD BOLT, 1/2"-13 UNC-2Ax2"

SAE J429 GR 5

HEX NUT, 1/2"-13 UNC-2B

CARBON STEEL, ASTM A563, GR A

SHEAR BOLT, M12 X 1.75

STEEL, GR 8.8, ISO R898

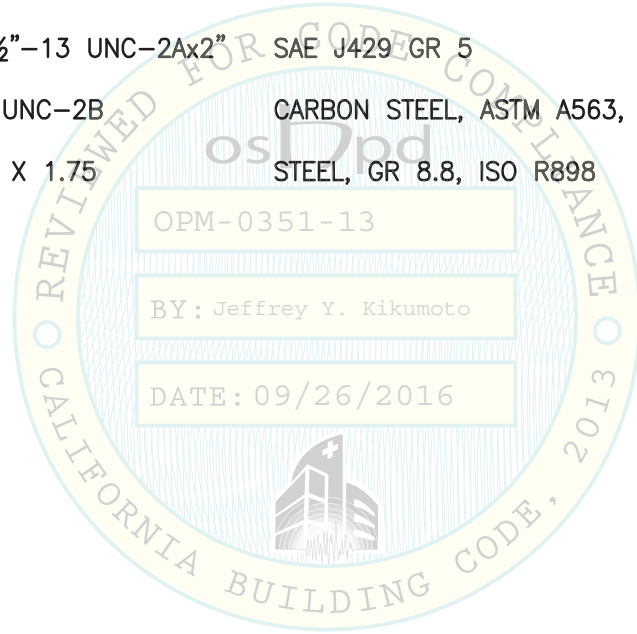

SHEET TITLE: MATERIAL SPECIFICATIONS

FIGURE 770 - Q BRACE CLAMP; FIGURE 771 - SWAY BRACE SWIVEL ATTACHMENT



CYS STRUCTURAL ENGINEERS, INC.

2495 NATOMAS PARK DRIVE, SUITE 650
SACRAMENTO, CA 95833

TEL (916) 920-2020
www.cyseng.com

Job No:	14090
Date:	09-22-2016
Page:	49 of 60

L:\Jobs\14090 Anvil - Fire Sprinkler System OPM-0351-13\ACAD\STRU\S1.dwg Time:Sep22,2016-02:18pm Login:camachom DimScale:1 LTScale:4

SEISMIC SWAY BRACING FOR FIRE PROTECTION SYSTEMS

6.3 FIGURE 772 – ADJUSTABLE STEEL BEAM ATTACHMENT

BEAM C-CLAMP	ASTM A1011, DS, TYPE B
ATTACHMENT CHANNEL	ASTM A36 CHANNEL 2 X 1 X $\frac{3}{16}$
HEX HEAD C-CLAMP BOLT, $\frac{1}{2}$ "-13 UNC-2A X 3" FOR $\frac{3}{4}$ " MAX FLANGE THICKNESS	CARBON STEEL, ASTM A307, GR A
HEX HEAD C-CLAMP BOLT, $\frac{1}{2}$ "-13 UNC-2A X $3\frac{1}{2}$ " FOR $1\frac{1}{4}$ " MAX FLANGE THICKNESS	CARBON STEEL, ASTM A307, GR A
FLAT WASHER	CARBON STEEL, ASTM F844, TYPE A
SPRING LOCK WASHER, $\frac{1}{2}$ "	CARBON STEEL, ROCKWELL HARDNESS C45-51
SHEAR BOLT, M12 X 1.75	STEEL, GR 8.8, ISO R898
PUSH-NUT BOLT RETAINER	LOW CARBON STEEL
CARRIAGE BOLT, $\frac{1}{2}$ "-13 UNC-2Ax $1\frac{1}{2}$ "	SAE J429 GR 5
HEAVY HEX HEAD MOUNTING NUT, $\frac{1}{2}$ "-13 UNC-2B	CARBON STEEL, ASTM A563, GR A
WASHER, $\frac{5}{8}$ "	LOW CARBON STEEL, HARDENED, ASTM F436

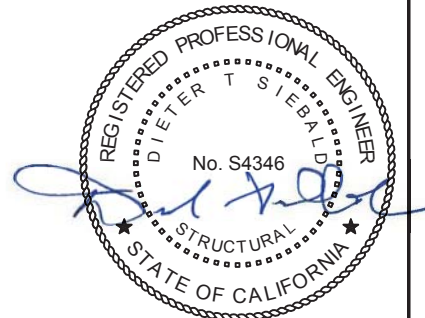
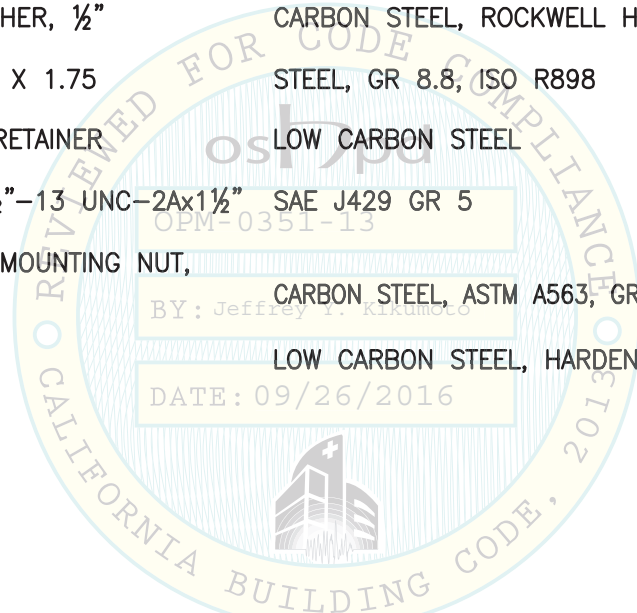

L:\Jobs\14090 Anvil - Fire Sprinkler System OPM-0351-13\ACAD\STRU\S1.dwg Time:Sep22,2016-02:18pm Login:camachom DimScale:1 LTScale:4

SHEET TITLE: MATERIAL SPECIFICATIONS
FIGURE 772 - ADJUSTABLE STEEL BEAM ATTACHMENT

 CYS STRUCTURAL ENGINEERS, INC. 2495 NATOMAS PARK DRIVE, SUITE 650 SACRAMENTO, CA 95833	TEL (916) 920-2020 www.cyseng.com	Job No: 14090 Date: 09-22-2016 Page: 50 of 60
---	--------------------------------------	---

SEISMIC SWAY BRACING FOR FIRE PROTECTION SYSTEMS

6.4. FIGURE 775 – LATERAL/LONGITUDINAL BRACE CLAMP

BRACE PIPE CONNECTOR	DUCTILE IRON, ASTM A536 GR 65-45-12
PIPE CLAMP, PIPE SIZE 2½" – 5"	ASTM A1011, CS TYPE, TYPE A, B, OR C (OR ASTM A36)
PIPE CLAMP, PIPE SIZE 6" – 8"	A515 GR 65 – 70 (OR ASTM A36)
HEX BOLT, M12 X 1.75	STEEL, GR 8.8, ISO R898
<u>PIPE SIZE 2½" – 5 ASSEMBLY</u>	
HEX HEAD BOLT, ½"-13 UNC-2A X 2"	SAE J429 GR 5
FLAT WASHER, ½"	CARBON STEEL, ASTM F844, TYPE A
HEX NUT, ½"-13 UNC-2B	CARBON STEEL, ASTM A563, GR A
SPACER	CARBON STEEL, ASTM A53, GR B OR A106 GR B
<u>PIPE SIZE 6 – 8 ASSEMBLY</u>	
HEX HEAD BOLT, ¾"-10 UNC-2A X 3"	SAE J429 GR 5
FLAT WASHER, ¾"	CARBON STEEL, ASTM F844, TYPE A
HEX NUT, ¾"-10UNC-2B	CARBON STEEL, ASTM A563 GR A
SPACER	CARBON STEEL, ASTM A53, GR B OR A106 GR B

6.5. FIGURE 776 – BRACE CLAMP

PIPE CLAMP RETAINER CLIP	ASTM A1011, CS, TYPE A, B, OR C
PIPE CLAMP HOOP SECTION	ASTM A1011, DS, TYPE B
HEX HEAD SET SCREW, ¼"-13UNC-2A X 1" 26/26	STEEL, SAE J429 GR 5

6.6. FIGURE 778 – BAR JOIST BEAM ATTACHMENT

BAR ATTACHMENT	DUCTILE IRON, ASTM A536, GR 65-45-12
SHEAR BOLT, M12 X 1.75	STEEL, GR 8.8, ISO R898
HEX HEAD CAP SCREW, ½"-13 UNC-2A X 1½"	CARBON STEEL, ASTM A307, GR A

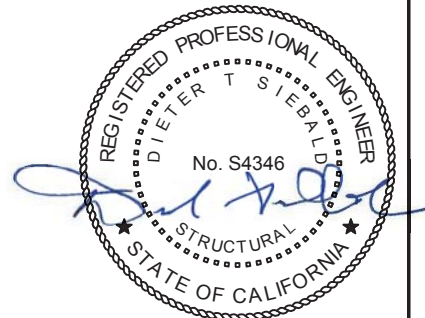
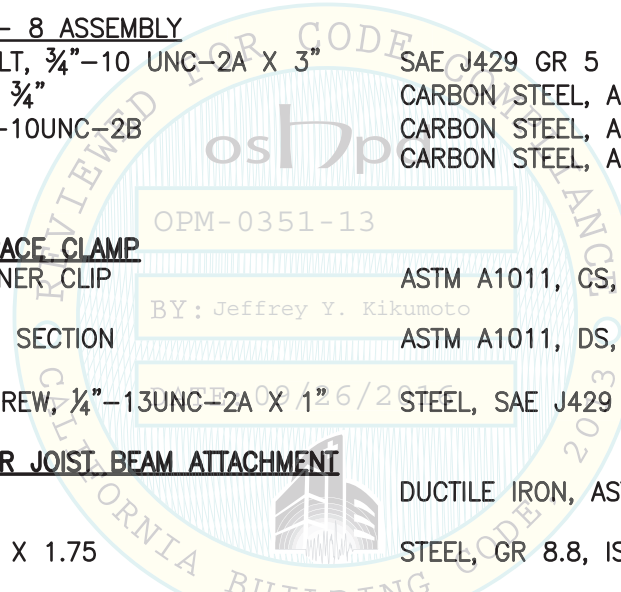

SHEET TITLE: MATERIAL SPECIFICATIONS
 LATERAL / LONGITUDINAL BRACE CLAMP; BRACE CLAMP; BAR JOIST BEAM ATTACHMENT



CYS STRUCTURAL ENGINEERS, INC.

2495 NATOMAS PARK DRIVE, SUITE 650
 SACRAMENTO, CA 95833

TEL (916) 920-2020
 www.cyseng.com

Job No:	14090
Date:	09-22-2016
Page:	51 of 60

L:\Jobs\14090 Anvil - Fire Sprinkler System OPM-0351-13\ACAD\STRU\S1.dwg Time:Sep22,2016-02:18pm Login:camachom Dimscale:1 LTScale:4

SEISMIC SWAY BRACING FOR FIRE PROTECTION SYSTEMS

7. RISER FOUR-WAY SEISMIC BRACES

7.1. FIGURE 770 - Q BRACE CLAMP

7.1.1 EA PRINCIPAL LOAD DIRECTION (#1 OR #2) AS SHOWN IN FIGURE 7.1.1 SHALL BE EVALUATED BY THE CRDP FOR $\pm F_p$ OR $\pm F_{pw}$.

7.1.2 PER NFPA® 13, ONE PAIR OF BRACES IS REQ FOR FOUR-WAY SEISMIC BRCG OF VERT RISERS.

7.1.3 FOR MAX ALLOWABLE LATERAL SEISMIC LOAD OF FIGURE 770, SEE TRANS SEISMIC LOAD IN TABLE 5.1.2.

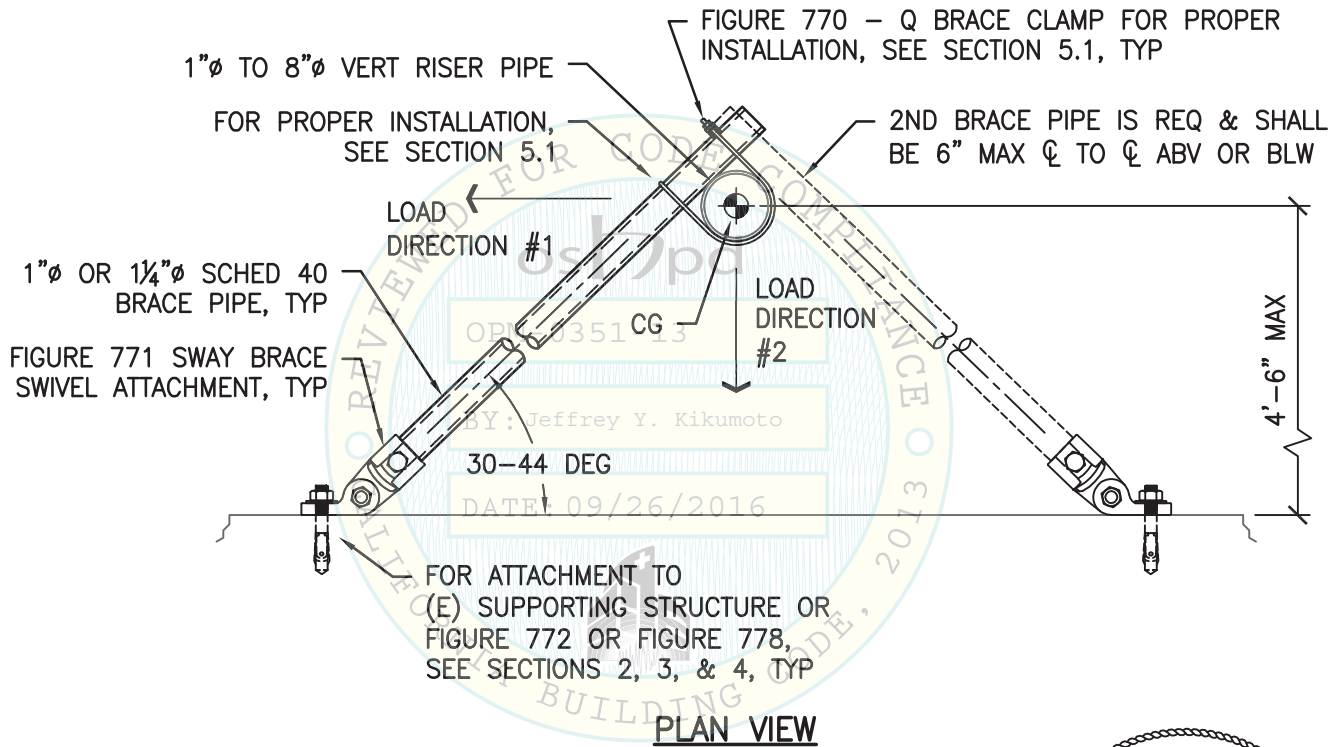

FIGURE 7.1.1 - RISER FOUR-WAY SEISMIC BRACE USING FIGURE 770 - Q BRACE CLAMP



SHEET TITLE: RISER FOUR-WAY SEISMIC BRACES
FIGURE 770 - Q BRACE CLAMP



CYS STRUCTURAL ENGINEERS, INC.

2495 NATOMAS PARK DRIVE, SUITE 650
SACRAMENTO, CA 95833

TEL (916) 920-2020
www.cyseng.com

Job No:	14090
Date:	09-22-2016
Page:	52 of 60

L:\Jobs\14090 Anvil - Fire Sprinkler System OPM-0351-13\ACAD\STRU\S1.dwg Time:Sep22,2016-02:18pm Login:camachom DimScale:1 LScale:4

SEISMIC SWAY BRACING FOR FIRE PROTECTION SYSTEMS

7. RISER FOUR-WAY SEISMIC BRACES

7.2. FIGURE 775 – LATERAL BRACE CLAMP

7.2.1 EA PRINCIPAL LOAD DIRECTION (#1 OR #2) AS SHOWN IN FIGURE 7.2.1 SHALL BE EVALUATED BY THE CRDP FOR $\pm F_p$ OR $\pm F_{pw}$.

7.2.2 PER NFPA® 13, ONE PAIR OF BRACES IS REQ FOR FOUR-WAY SEISMIC BRCG OF VERT RISERS.

7.2.3 FOR MAX ALLOWABLE LATERAL SEISMIC LOAD OF FIGURE 775, SEE TRANS SEISMIC LOAD IN TABLE 5.2.2.

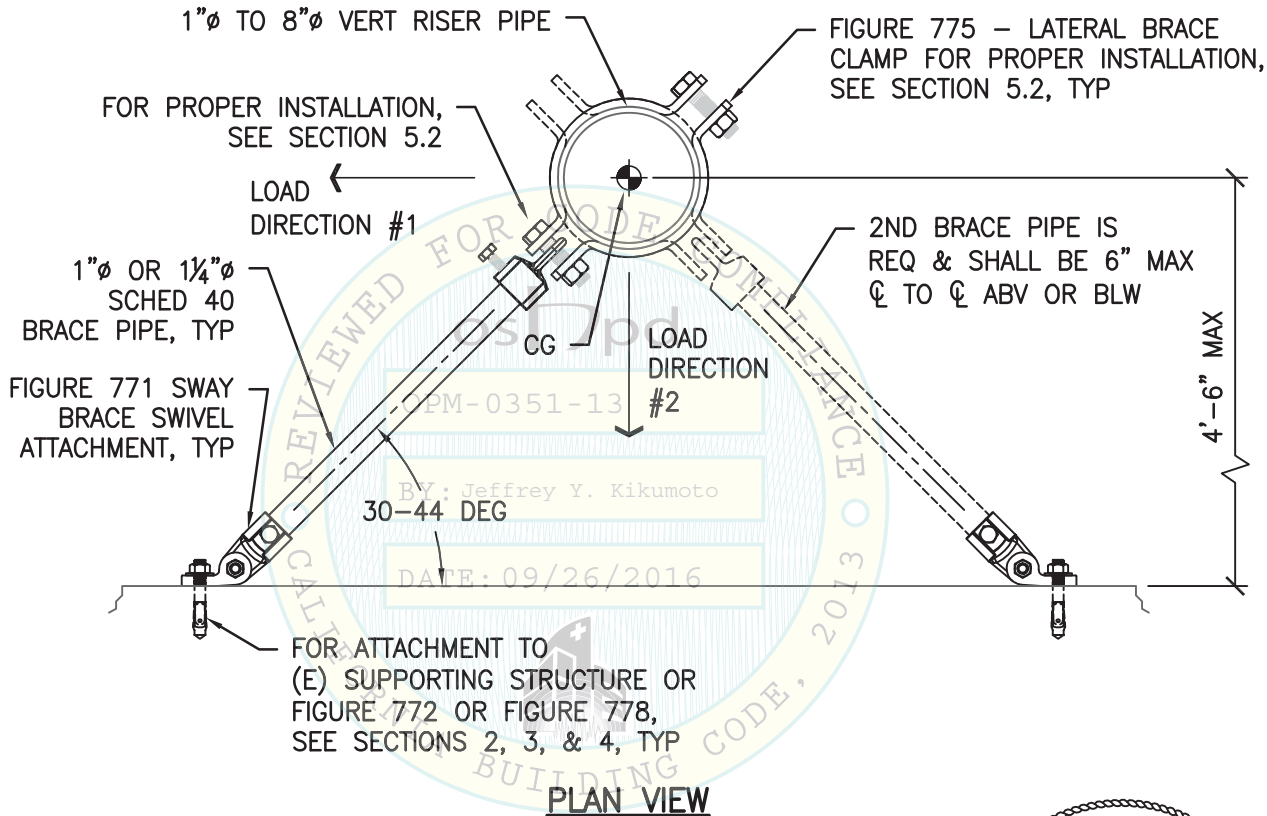
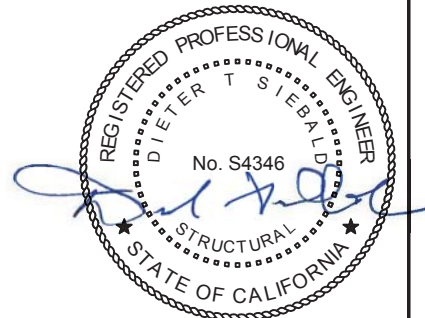

FIGURE 7.2.1 – RISER FOUR-WAY SEISMIC BRACE USING FIGURE 775– LATERAL BRACE CLAMP



SHEET TITLE: RISER FOUR-WAY SEISMIC BRACES
FIGURE 775 - LATERAL BRACE CLAMP



CYS STRUCTURAL ENGINEERS, INC.

2495 NATOMAS PARK DRIVE, SUITE 650
SACRAMENTO, CA 95833

TEL (916) 920-2020
www.cyseng.com

Job No:	14090
Date:	09-22-2016
Page:	53 of 60

L:\Jobs\14090 Anvil - Fire Sprinkler System OPM-0351-13\ACAD\STRU\S1.dwg Time:Sep22,2016 -02:18pm Login:camachom DimScale:1 LTScale:4

SEISMIC SWAY BRACING FOR FIRE PROTECTION SYSTEMS

7. RISER FOUR-WAY SEISMIC BRACES

7.3. FIGURE 776 – BRACE CLAMP

7.3.1 EA PRINCIPAL LOAD DIRECTION (#1 OR #2) AS SHOWN IN FIGURE 7.3.1 SHALL BE EVALUATED BY THE CRDP FOR $\pm F_p$ OR $\pm F_{pw}$.

7.3.2 PER NFPA® 13, ONE PAIR OF BRACES IS REQ FOR FOUR-WAY SEISMIC BRCG OF VERT RISERS.

7.3.3 FOR MAX ALLOWABLE LATERAL SEISMIC LOAD OF FIGURE 776, SEE TRANS SEISMIC LOAD IN TABLE 5.3.1.

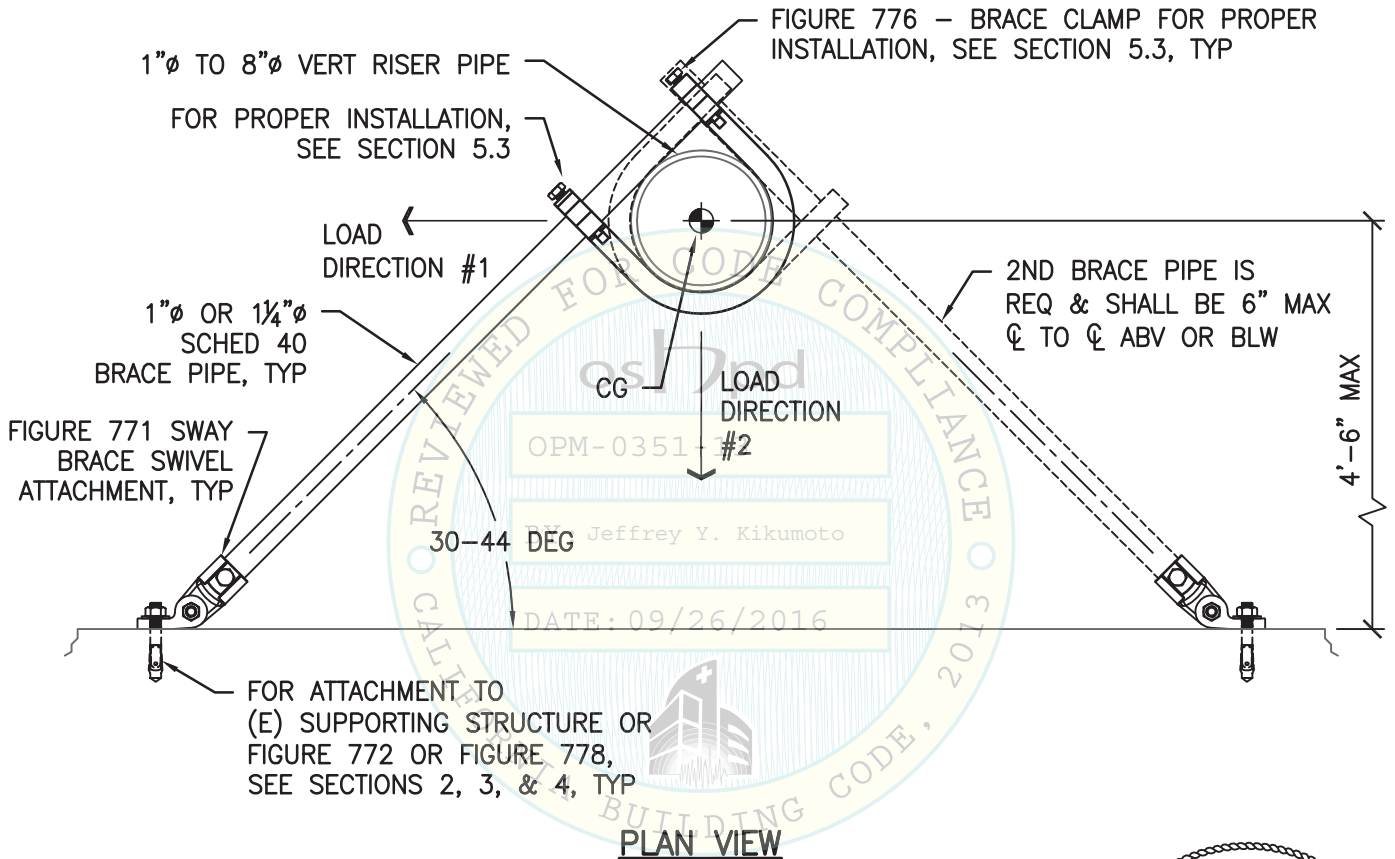

FIGURE 7.3.1 – RISER FOUR-WAY SEISMIC BRACE USING FIGURE 776– BRACE CLAMP



SHEET TITLE: RISER FOUR-WAY SEISMIC BRACES
FIGURE 776 - BRACE CLAMP



CYS STRUCTURAL ENGINEERS, INC.

2495 NATOMAS PARK DRIVE, SUITE 650
SACRAMENTO, CA 95833

TEL (916) 920-2020
www.cyseng.com

Job No:	14090
Date:	09-22-2016
Page:	54 of 60

L:\Jobs\14090 Anvil - Fire Sprinkler System OPM-0351-13\ACAD\STRU\S1.dwg Time:Sep22,2016--02:18pm Login:camachom DimScale:1 LScale:4

SEISMIC SWAY BRACING FOR FIRE PROTECTION SYSTEMS

8. TYPICAL SWAY BRACE DESIGN PROCEDURE

8.1 STEP 1

THE CRDP REVIEWS SECTION 1 OF THIS OPM.

NOTE: THIS EXAMPLE ASSUMES THE CRDP IS FAMILIAR W/ NFPA-13 SECTION 9.3.5.

8.2 STEP 2 – DETERMINE SEISMIC DESIGN CRITERIA FOR THE PROJECT SITE

GIVEN FOR THIS EXAMPLE

PER SECTION 1.5 OF THIS OPM

$$a_p = 2.5 \quad R_p = 4.5 \text{ (FOR PIPING W/ GROOVED COUPLINGS)}$$

$$I_p = 1.5 \quad \Omega_0 = 2.5 \text{ (FOR CONC ANCHORS ONLY)}$$

PIPING IS LOCATED AT ROOF LEVEL WHERE $z/h \leq 1.0$

PROJECT SITE $S_{DS} = 2.00$

APPLIED LOAD IS 4'-0" BLW POINT OF ATTACHMENT TO SUPPORTING STRUCTURE

DETERMINE SEISMIC DESIGN FORCE

$$F_p = 0.4 a_p S_{DS} I_p (1 + 2z/h) / R_p W_p = 2.00 W_p \text{ (GOVERNS DESIGN)}$$

$$F_p \text{ (min)} = 0.3 S_{DS} I_p W_p = 0.90 W_p$$

$$F_p \text{ (max)} = 1.6 S_{DS} I_p W_p = 4.80 W_p$$

ASD LOAD COMBINATIONS FOR ALL SUPPORTS & ATTACHMENTS EXCEPT CONC ANCHORS

$$(1.0 + 0.14 S_{DS}) D \pm 0.7 F_p = 1.28D \pm 0.7F_p$$

$$(0.6 - 0.14 S_{DS}) D \pm 0.7 F_p = 0.32D \pm 0.7F_p$$

LRFD LOAD COMBINATIONS FOR CONC ANCHORS

$$(1.2 + 0.2 S_{DS}) D \pm \Omega_0 F_p = 1.6D \pm 2.5F_p$$

$$(0.9 - 0.2 S_{DS}) D \pm \Omega_0 F_p = 0.5D \pm 2.5F_p$$

8.3 STEP 3 – DETERMINE SEISMIC DEMANDS

GIVEN FOR THIS EXAMPLE

- MAIN SERVICE PIPE 4" SCHED 40 W/ GRAVITY HANGER SPACING = 15 ft
- THREE BRANCH LINES 1½" SCHED 10, EA BRANCH LINE IS 20 ft LONG
- LATERAL SWAY BRACE SPCG (SERVICE PIPE SPAN) = 30 ft
- PER NFPA-13 SECTION E.2.2, ASSUME BRANCH LINES AT THIRD-POINTS OF PIPE SPAN & NEAR EA SUPPORT
- BRACES INSTALLED AT A BRACE ANGLE (θ) = 50°
- PER SECTION 1.4 OF THIS OPM, BRACE ANGLE CONSTRUCTION TOLERANCES OF $\pm 5^\circ$ MUST BE CONSIDERED DURING DESIGN.
- WTS OF WATER-FILLED PIPES PER TABLE 1.2.1 OF THIS OPM



SHEET TITLE: TYPICAL SWAY BRACE DESIGN PROCEDURE



CYS STRUCTURAL ENGINEERS, INC.

2495 NATOMAS PARK DRIVE, SUITE 650
SACRAMENTO, CA 95833

TEL (916) 920-2020
www.cyseng.com

Job No:	14090
Date:	09-22-2016
Page:	55 of 60

SEISMIC SWAY BRACING FOR FIRE PROTECTION SYSTEMS

8.3 STEP 3 – DETERMINE SEISMIC DEMANDS (CONTINUED)

DETERMINE GRAVITY LOAD TRIBUTARY TO VERT BRACE

$$W = \text{WT OF MAIN LINE (4" SCHED 40)} = 16.40 \text{ plf} \times 15 \text{ ft} = 246 \text{ lbs}$$

DETERMINE LOAD IN THE (ZOI) OF A TRANS SWAY BRACE

$$\text{WT OF MAIN LINE (4" SCHED 40)} = 16.40 \text{ plf} \times 30 \text{ ft} = 492 \text{ lbs}$$

$$\text{WT OF BRANCH LINES (1\frac{1}{2}" SCHED 10)} = 3 \times 3.04 \text{ plf} \times 20 \text{ ft} = 182 \text{ lbs}$$

$$W_p = 1.15 (492 + 182) = 776 \text{ lbs}$$

CALCULATE HORIZ SEISMIC FORCE ON TRANS SWAY BRACE

$$F_p = 2.00W_p = 2.00 (776) = 1552 \text{ lbs}$$

$$F_{pw} = 0.7F_p = 1086 \text{ lbs (ASD LEVEL FORCE)}$$

CALCULATE SUPPORT FORCES & ATTACHMENT REACTIONS

$$\text{ASD LOAD COMBINATIONS: } 1.28W \pm 0.7F_p$$

$$0.32W \pm 0.7F_p$$

$$P_{a,T} \text{ MAX} = (1086/\sin 45^\circ) = \pm 1536 \text{ lbs}$$

$$\text{at } L = (4.0/\cos 45^\circ) = 5.66'$$

$$P_{a,T} \text{ MIN} = (1086/\sin 55^\circ) = \pm 1326 \text{ lbs}$$

$$\text{at } L = (4.0/\cos 55^\circ) = 6.97'$$

$$P_{a,V} \text{ TENSION} = 1.28(-246) - (1086/\tan 45^\circ) = -1401 \text{ lbs}$$

$$P_{a,V} \text{ COMPRESSION} = 0.32(-246) + (1086/\tan 45^\circ) = +1008 \text{ lbs}$$

$$R_{H,B} = 0.7F_p = 1086 \text{ lbs SHEAR}$$

$$R_{V,B} = (R_{H,B}/\tan 45^\circ) = 1086 \text{ lbs MAX TENSION}$$

$$R_{V,A} = 1401 \text{ lbs MAX TENSION}$$

CALCULATE REACTIONS FOR CONC ANCHORS

$$\text{LRFD LOAD COMBINATIONS: } 1.6D + 2.5F_p$$

$$0.5D - 2.5F_p$$

$$R_{H,B} = 2.5F_p = 2.5 (1552) = 3880 \text{ lbs SHEAR}$$

$$R_{V,B} = (R_{H,B}/\tan 45^\circ) = 3880 \text{ lbs MAX TENSION}$$

$$R_{V,A} = 1.6(-246) - (3880/\tan 45^\circ) = 4274 \text{ lbs MAX TENSION}$$

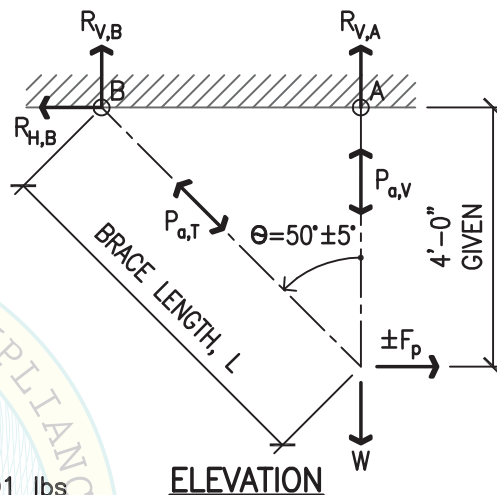

ELEVATION

$P_{a,T}$ = TRANS SEISMIC BRACE AXIAL FORCE
 $P_{a,V}$ = VERT SEISMIC BRACE AXIAL FORCE

NOTE: WHERE BOTH A LONG & A TRANS SEISMIC BRACE ARE LOCATED WITHIN 6" OF THE SAME VERT SEISMIC BRACE, THE AXIAL FORCE DUE TO EA SWAY BRACE SHALL BE CONSIDERED. THIS EXAMPLE HAS NO LONG SEISMIC BRACE AT THIS VERT SEISMIC BRACE.

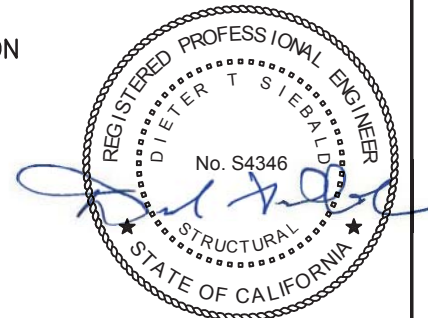

SHEET TITLE: TYPICAL SWAY BRACE DESIGN PROCEDURE



CYS STRUCTURAL ENGINEERS, INC.

2495 NATOMAS PARK DRIVE, SUITE 650
 SACRAMENTO, CA 95833

TEL (916) 920-2020
 www.cyseng.com

Job No:	14090
Date:	09-22-2016
Page:	56 of 60

SEISMIC SWAY BRACING FOR FIRE PROTECTION SYSTEMS

8.4 STEP 4- VERIFY CAPACITIES

VERIFY SERVICE PIPE FLEXURAL CAPACITY FOR CALCULATED (ZOI) LOAD (SECTION 8.5 OF THIS OPM) PER TABLE 8.5.2, THE MAX ALLOWABLE (ZOI) LOAD (F_{pw}) FOR A 4" SCHED 40 MAIN SERVICE PIPE SPANNING 30 ft IS 1828 lbs WHICH IS LARGER THAN THE CALCULATED DEMAND OF 1086 lbs.

THEREFORE, THE 4" SCHED 40 MAIN SERVICE PIPE IS ADEQUATE FOR THE SEISMIC LOAD.

NOTE: IF THE DEMAND EXCEEDED THE ALLOWABLE, THE 30 ft LATERAL SWAY BRACE SPCG WOULD HAVE TO BE REDUCED.

TRANS SEISMIC BRACE (LATERAL SWAY BRACE)

SELECT APPROPRIATE SEISMIC BRACE CLAMP (SECTION 5 OF THIS OPM)

PER TABLE 5.2.2, THE MAX ALLOWABLE HORIZ LOAD FOR A FIGURE 775 BRACE CLAMP ON A 4" MAIN SERVICE PIPE FOR TRANS SWAY BRACE INSTALLED AT ANGLE OF 45°-55° IS 1810 lbs WHICH IS LARGER THAN THE CALCULATED DEMAND OF 1086 lbs.

THEREFORE, USE FIGURE 775 BRACE CLAMP.

SELECT TRANS BRACE PIPE SIZE (SECTION 1.2 OF THIS OPM)

PER TABLE 1.2.3, FOR A TRANS SWAY BRACE DEMAND OF 1536 lbs AND 6.97 ft MAX LENGTH, SELECT A 1/4" SCHED 40 ASTM A53 GR A BRACE PIPE W/ AN AXIAL CAPACITY OF 1875 lbs UP TO A MAX LENGTH OF 9'-0".

VERIFY SWAY BRACE SWIVEL ATTACHMENT (SECTION 4.1 OF THIS OPM)

PER TABLE 4.1.1, THE MAX ALLOWABLE HORIZ LOAD FOR A FIGURE 771 SWAY BRACE SWIVEL CONNECTOR AT A TRANS SWAY BRACE INSTALLED AT ANGLE OF 45°-55° IS 2540 lbs WHICH IS LARGER THAN THE CALCULATED DEMAND OF 1086 lbs.

CHECK 2 OPTIONS FOR ATTACHMENT TO STRUCTURE 6

OPTION 1: SELECT APPROPRIATE ATTACHMENT TO STL BM (SECTION 4.2 & 4.3 OF THIS OPM)

PER TABLE 4.2.1, FOR A STL BEAM SIZE OF W18x60, USE FIGURE 772 SIZE TYPE A. PER TABLE 4.2.2, THE MAX ALLOWABLE HORIZ LOAD FOR A FIGURE 772 TYPE A ADJUSTABLE STL BEAM ATTACHMENT INSTALLED AT ANGLE OF 45°-55° PERP TO A STL BM IS 710 lbs WHICH IS SMALLER THAN THE CALCULATED DEMAND OF 1086 lbs.

THEREFORE, FIGURE 772 ATTACHMENT IS NO GOOD, TRY FIGURE 778 ATTACHMENT. PER TABLE 4.3.1, THE MAX ALLOWABLE HORIZ LOAD FOR A FIGURE 778 WF BM FLANGE ATTACHMENT INSTALLED AT ANGLE OF 45°-55° PERP TO A STL BEAM IS 2260 lbs WHICH IS LARGER THAN THE CALCULATED DEMAND OF 1086 lbs.

THEREFORE, USE FIGURE 778 WF BM FLANGE ATTACHMENT.



SHEET TITLE: TYPICAL SWAY BRACE DESIGN PROCEDURE



CYS STRUCTURAL ENGINEERS, INC.

2495 NATOMAS PARK DRIVE, SUITE 650
SACRAMENTO, CA 95833

TEL (916) 920-2020
www.cyseng.com

Job No:	14090
Date:	09-22-2016
Page:	57 of 60

SEISMIC SWAY BRACING FOR FIRE PROTECTION SYSTEMS

8.4 STEP 4- VERIFY CAPACITIES (CONTINUED)

OPTION 2: CHECK ATTACHMENT TO SOFFIT OF CONC FILLED MTL DECK (SECTION 2.2.2 OF THIS OPM) THE CRDP SHALL CHECK THE CONC ANCHORS FOR THE EFFECTS OF COMBINED TENSION & SHEAR FORCES (INCLUDING PRYING ACTION) IN ACCORDANCE W/ ACI 318-11 SECTION D.7. DESIGN STRENGTH CAPACITY VALUES IN TENSION & SHEAR ARE PROVIDED IN TABLE 2.2.2 FOR 1/2" ANCHORS IN A COMMON INSTALLATION TO UNDERSIDE OF CONC FILLED MTL DECK. THE CRDP SHALL DESIGN ANCHORS FOR ANY OTHER INSTALLATIONS IN ACCORDANCE W/ ACI 318-11 APPENDIX D & ICC REPORTS. USE OF MFR'S SOFTWARE TO AID DESIGN IS RECOMMENDED.

$$R_{v,B} = R_{h,B} = 3880 \text{ lbs PER PREVIOUS CALC}$$

$$V_{ua} = R_{h,B} = 3880 \text{ lbs}$$

$$M_c = R_{v,B}(1.65") - R_{h,B}(0.81") = 3259 \text{ ft-lb}$$

$$N_{ua} = R_{v,B} + M_c/(0.9*0.84) = 8191 \text{ lbs}$$

$$N_{ua}/\phi N_n + V_{ua}/\phi V_n \leq 1.2$$

$$8191/1270 + 3880/2450 >>> 1.2$$

THEREFORE, ANCHOR IS NO GOOD & DESIGN MUST BE REVISED.

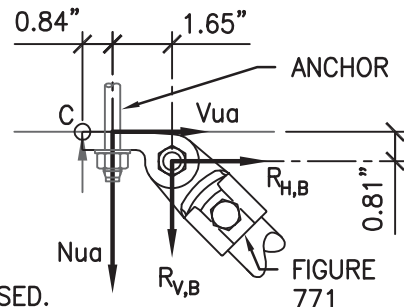

PRYING ACTION DIAGRAM

VERT SEISMIC BRACE

SELECT APPROPRIATE SEISMIC BRACE CLAMP (SECTION 5 OF THIS OPM)

PER TABLE 5.2.2, THE MAX ALLOWABLE HORIZ LOAD FOR A FIGURE 775 BRACE CLAMP ON A 4" MAIN SERVICE PIPE FOR VERT BRACE INSTALLED AT ANGLE OF 0° IS 1280 lbs WHICH IS LARGER THAN THE CALCULATED DEMAND OF 1086 lbs. THEREFORE, USE FIGURE 775 BRACE CLAMP.

SELECT VERT BRACE PIPE SIZE (SECTION 1.2 OF THIS OPM)

PER TABLE 1.2.3, FOR A VERT BRACE DEMAND OF 1008 lbs AND 4.0 ft MAX LENGTH, SELECT A 1" SCHED 40 ASTM A53 GR A BRACE PIPE WITH AN AXIAL CAPACITY OF 1406 lbs UP TO A MAX LENGTH OF 7'-0".

VERIFY SWAY BRACE SWIVEL ATTACHMENT (SECTION 4.1 OF THIS OPM)

PER TABLE 4.1.1, THE MAX ALLOWABLE LOAD FOR A FIGURE 771 SWAY BRACE SWIVEL CONNECTOR AT A VERT BRACE INSTALLED AT ANGLE OF 0° IS 1800 lbs WHICH IS LARGER THAN THE VERT BRACE DEMAND OF 1008 lbs.

SELECT APPROPRIATE ATTACHMENT TO STL BM (SECTION 4.2 OF THIS OPM)

PER TABLE 4.2.1, FOR A STL BM SIZE OF W18x60, USE FIGURE 772 SIZE TYPE A. PER TABLE 4.2.2, THE MAX ALLOWABLE LOAD FOR A FIGURE 772 TYPE A ADJUSTABLE STL BM ATTACHMENT INSTALLED AT ANGLE OF 0° PERP TO A STL BM IS 470 lbs WHICH IS LESS THAN THE VERT BRACE DEMAND OF 1008 lbs. THEREFORE, FIGURE 772 ATTACHMENT IS NO GOOD & DESIGN MUST BE REVISED.



SHEET TITLE: TYPICAL SWAY BRACE DESIGN PROCEDURE



CYS STRUCTURAL ENGINEERS, INC.

2495 NATOMAS PARK DRIVE, SUITE 650
SACRAMENTO, CA 95833

TEL (916) 920-2020
www.cyseng.com

Job No:	14090
Date:	09-22-2016
Page:	58 of 60

SEISMIC SWAY BRACING FOR FIRE PROTECTION SYSTEMS

8.5 MAX PERMISSIBLE LOAD IN THE ZONE OF INFLUENCE OF A SWAY BRACE

THE MAX PERMISSIBLE LOAD IN THE ZONE OF INFLUENCE (ZOI) OF A SWAY BRACE SHALL NOT EXCEED THE VALUES GIVEN IN TABLE 8.5.1, TABLE 8.5.2, OR TABLE 8.5.3 IN THIS OPM IN LIEU OF TABLE 9.3.5.5.2(a), TABLE 9.3.5.5.2(b), OR TABLE 9.3.5.5.2(c) AS SHOWN IN 2013 NFPA-13. THE TABLES ARE BASED ON COMMON CONFIGURATIONS OF MAINS & BRANCH LINES PER NFPA-13 SECTION E.2.2. WHERE THE CONFIGURATION OF THE MAINS & BRANCH LINES VARY SIGNIFICANTLY FROM THE ASSUMED LAYOUT, THE PIPE STRESSES SHOULD BE CHECKED BY ENGINEERING ANALYSIS. PLEASE NOTE: THE THREE TABLES DIFFER FROM THE NFPA-13 PUBLISHED VALUES BECAUSE THEY CONSIDER VERT PLUS LATERAL LOAD DEMAND & USE $t_{design} = 0.96t_{nom}$ AS PER TABLE FOOTNOTES.

SERVICE PIPE NPS ¹	OD (IN)	t_{nom} ¹ (IN)	S ² (IN ³)	WATER-FILLED PIPE WT (PLF)	GRAVITY HANGER SPCG ³ (FT)	LATERAL SWAY BRACE SPCG ⁴ (FT)				
						20 ⁵	25 ⁵	30 ⁶	35 ⁶	40 ⁷
1	1.315	0.109	0.11	1.81	12	99	79	65		
1 1/4	1.660	0.109	0.18	2.51	12	166	133	109		
1 1/2	1.900	0.109	0.24	3.05	15	219	176	144		
2	2.375	0.109	0.39	4.22	15	357	286	234		
2 1/2	2.875	0.120	0.64	5.90	15	587	470	385		
3	3.500	0.120	0.98	7.95	15	893	714	585	501	420
3 1/2	4.000	0.120	1.29	9.79	15	1182	946	775	664	556
4	4.500	0.120	1.65	11.80	15	1513	1210	991	850	712
5	5.563	0.134	2.83	17.32	15	2608	2086	1709	1465	1227
6	6.625	0.134	4.06	23.05	15	3743	2995	2453	2103	1761
8	8.625	0.188	9.61	40.11	15	8891	7112	5827	4995	4182

TABLE 8.5.1 - MAX LOAD (F_{pw}) IN ZOI (LBS), ($F_y = 30$ KSI MIN) SCHEDULE 10 STEEL PIPE

FOOTNOTES FOR TABLE 8.5.1, TABLE 8.5.2 & TABLE 8.5.3

- ¹ STL PIPE DIMS (NOMINAL WALL THK (t_{nom}) & OD) PER NFPA TABLE A.6.3.2, EXCEPT LW-SCHEDULE t_{nom} PER ANVIL.
- ² SECTION MODULUS, $S = [\pi(OD)^4 - (OD - 2t_{design})^4] / 32(OD)$ WHERE $t_{design} = 0.93t_{nom}$ PER AISC 360.
- ³ MAX DISTANCE BETWEEN GRAVITY HANGERS PER NFPA TABLE 9.2.2.1(a).
- ⁴ THE TABLES FOR MAX LOAD (F_{pw}) IN ZOI ARE BASED ON SPECIFIC CONFIGURATIONS OF MAINS & BRANCH LINES, SEE NFPA SECTION E.2.2.
- ⁵ ASSUMES BRANCH LINES AT CENTER OF PIPE SPAN & NEAR EA SUPPORT.
- ⁶ ASSUMES BRANCH LINES AT THIRD-POINTS OF PIPE SPAN & NEAR EA SUPPORT.
- ⁷ ASSUMES BRANCH LINES AT QUARTER-POINTS OF PIPE SPAN & NEAR EA SUPPORT.



SHEET TITLE: TYPICAL SWAY BRACE DESIGN PROCEDURE



CYS STRUCTURAL ENGINEERS, INC.

2495 NATOMAS PARK DRIVE, SUITE 650
SACRAMENTO, CA 95833

TEL (916) 920-2020
www.cyseng.com

Job No:	14090
Date:	09-22-2016
Page:	59 of 60

SEISMIC SWAY BRACING FOR FIRE PROTECTION SYSTEMS

8.5 MAX PERMISSIBLE LOAD IN THE ZONE OF INFLUENCE OF A SWAY BRACE (CONTINUED)

SERVICE PIPE NPS ¹	OD (IN)	t _{nom} ¹ (IN)	S ² (IN ³)	WATER-FILLED PIPE WT (PLF)	GRAVITY HANGER SPCG ³ (FT)	LATERAL SWAY BRACE SPCG ⁴ (FT)				
						20 ⁵	25 ⁵	30 ⁶	35 ⁶	40 ⁷
1	1.315	0.133	0.13	2.06	12	114	92	75		
1 1/4	1.660	0.140	0.22	2.92	12	203	162	133		
1 1/2	1.900	0.145	0.31	3.60	15	278	222	182		
2	2.375	0.154	0.53	5.11	15	481	385	315		
2 1/2	2.875	0.203	1.00	7.87	15	920	736	603		
3	3.500	0.216	1.62	10.79	15	1494	1195	979	839	703
3 1/2	4.000	0.226	2.25	13.40	15	2076	1661	1361	1166	977
4	4.500	0.237	3.02	16.32	15	2790	2232	1828	1567	1312
5	5.563	0.258	5.12	23.30	15	4733	3786	3102	2659	2226
6	6.625	0.280	7.97	31.51	15	7378	5902	4836	4145	3471
8 SCHED 30	8.625	0.277	13.8	46.89	15	12741	10193	8351	7158	5994

TABLE 8.5.2 - MAX LOAD (F_{pw}) IN ZOI (LBS), (F_y = 30 KSI MIN) SCHEDULE 40 STEEL PIPE

SERVICE PIPE NPS ¹	OD (IN)	t _{nom} ¹ (IN)	S ² (IN ³)	WATER-FILLED PIPE WT (PLF)	GRAVITY HANGER SPCG ³ (FT)	LATERAL SWAY BRACE SPCG ⁴ (FT)				
						20 ⁵	25 ⁵	30 ⁶	35 ⁶	40 ⁷
1	1.315	0.065	0.07	1.35	12	64	51	42		
1 1/4	1.660	0.065	0.12	1.91	12	106	85	70		
1 1/2	1.900	0.080	0.19	2.59	12	171	137	112		
2	2.375	0.080	0.30	3.63	12	275	220	180		
2 1/2	3.000	0.083	0.50	5.32	12	464	371	304		
3	3.500	0.083	0.69	6.81	12	640	512	419	359	301
4	4.500	0.092	1.29	10.68	12	1186	949	777	666	558
6	6.625	0.115	3.51	21.92	12	3250	2600	2130	1826	1529

TABLE 8.5.3 - MAX LOAD (F_{pw}) IN ZOI (LBS), (F_y = 30 KSI MIN) ROLL GROOVED LW STEEL PIPE (LW-SCHEDULE 7)

FOOTNOTES FOR TABLE 8.5.2 & TABLE 8.5.3
SEE PREVIOUS PAGE FOR FOOTNOTES



SHEET TITLE: TYPICAL SWAY BRACE DESIGN PROCEDURE



CYS STRUCTURAL ENGINEERS, INC.

2495 NATOMAS PARK DRIVE, SUITE 650
SACRAMENTO, CA 95833

TEL (916) 920-2020
www.cyseng.com

Job No:	14090
Date:	09-22-2016
Page:	60 of 60