



OFFICE OF STATEWIDE HEALTH PLANNING AND DEVELOPMENT
FACILITIES DEVELOPMENT DIVISION

APPLICATION FOR OSHPD PREAPPROVAL
OF MANUFACTURER'S CERTIFICATION (OPM)

OFFICE USE ONLY
APPLICATION #: OPM-0384-13

OSHPD Preapproval of Manufacturer's Certification (OPM)

Type: [X] New [ ] Renewal [ ] Update to Pre-CBC 2013 OPA Number:

Manufacturer Information

Manufacturer: Getinge USA

Manufacturer's Technical Representative: Don Socha

Mailing Address: 1777 E. Henrietta Road, Rochester, NY. 14623

Telephone: On File Email: On File

Product Information

Product Name: 88 Washer/Disinfecter

Product Type: Other Electrical & Mechanical Components

Product Model Number: 88

General Description: Washer/Disinfecter used to clean and disinfect medical instruments

Applicant Information

Applicant Company Name: EASE Co.

Contact Person: Jonathan Roberson, S.E.

Mailing Address: 5877 Pine Ave. Suite 210, Chino Hills, CA. 91709

Telephone: (909) 606-7622 Email: J.Roberson@EASECo.com

I hereby agree to reimburse the Office of Statewide Health Planning and Development review fees in accordance with the California Administrative Code, 2016.

Signature of Applicant: [Signature] Date: 10/19/16

Title: Principal Engineer Company Name: EASE Co.

"Access to Safe, Quality Healthcare Environments that Meet California's Diverse and Dynamic Needs"





**OFFICE OF STATEWIDE HEALTH PLANNING AND DEVELOPMENT  
FACILITIES DEVELOPMENT DIVISION**

**Registered Design Professional Preparing Engineering Recommendations**

Company Name: EASE Co.

Name: Jonathan Roberson, S.E. California License Number: S4197

Mailing Address: 5877 Pine Ave. Suite 210, Chino Hills, CA. 91709

Telephone: 909-606-7622 Email: J.Roberson@EASECo.com

**OSHPD Special Seismic Certification Preapproval (OSP)**

- Special Seismic Certification is preapproved under OSP-  
(Separate application for OSP is required)
- Special Seismic Certification is not preapproved

**Certification Method(s)**

- Testing in accordance with:  ICC-ES AC156  FM 1950-16
- Other\* (Please Specify): \_\_\_\_\_

\*Use of criteria other than those adopted by the California Building Standards Code, 2016 (CBSC 2016) for component supports and attachments are not permitted. For distribution system, interior partition wall, and suspended ceiling seismic bracings, test criteria other than those adopted in the CBSC 2016 may be used when approved by OSHPD prior to testing.

- Analysis
- Experience Data
- Combination of Testing, Analysis, and/or Experience Data (Please Specify): \_\_\_\_\_

**List of Attachments Supporting the Manufacturer's Certification**

- Test Report  Drawings  Calculations  Manufacturer's Catalog
- Other(s) (Please Specify): \_\_\_\_\_

**OFFICE USE ONLY – OSHPD APPROVAL VALID FOR CBC 2016 & ALL PRE-2016 CODE BASED PROJECTS**

Signature:  Date: 10-31-2017

Print Name: Jeffrey Kikumoto

Title: SSE

Condition of Approval (if applicable): \_\_\_\_\_

"Access to Safe, Quality Healthcare Environments that Meet California's Diverse and Dynamic Needs"





**EQUIPMENT ANCHORAGE  
& SEISMIC ENGINEERING**

5877 Pine Ave, Ste. 210  
Chino Hills, CA. 91709  
Phn: (909) 606-7622

Office of Statewide Health Planning and Development  
**PREAPPROVAL OF MANUFACTURER'S CERTIFICATION**  
**OPM-0384-13**

**THIS PREAPPROVAL CONFORMS TO THE 2016 CALIFORNIA BUILDING CODE**

MANUFACTURER: **GETINGE USA**  
EQUIPMENT NAME: **88 SERIES WASHER/DISINFECTOR**

Sheet: 1 of 9

Date: 9/1/17

**GENERAL NOTES**

1. THIS OSHPD PREAPPROVAL OF MANUFACTURER'S CERTIFICATION (OPM) IS BASED ON THE 2016 CBC. THE DEMANDS (DESIGN FORCES) FOR USE WITH THIS OPM SHALL BE BASED ON THE 2016 CBC
2. THIS DOCUMENT MAY ONLY BE USED WITH THE EXPRESS WRITTEN CONSENT OF THE MANUFACTURER LISTED ABOVE FOR THE SPECIFIC PROJECT SITE AND INSTALLATION LOCATION. THIS DOCUMENT IS INVALID WITHOUT SUCH CONSENT.
3. THIS PREAPPROVAL CONFORMS TO THE 2016 CALIFORNIA BUILDING CODE WHERE  $S_{ds}$  IS NOT GREATER THAN 1.80, 2.10 & 2.20. SEE DETAIL FOR APPLICABILITY
4. FORCES PER ASCE 7-10 SECTION 13.3.1, EQUATIONS 13.3-1, 13.3-2 & 13.3-3,  
WHERE  $S_{ds} = 1.80$ ,  $a_p = 1.0$ ,  $I_p = 1.5$ ,  $R_p = 1.5$ ,  $z/h = 0$  AT CONCRETE SLAB. SEE FOLLOWING SHEETS FOR  $\Omega_o$   
WHERE  $S_{ds} = 2.20$ ,  $a_p = 1.0$ ,  $I_p = 1.5$ ,  $R_p = 1.5$ ,  $z/h = 0$  AT CONCRETE SLAB. SEE FOLLOWING SHEETS FOR  $\Omega_o$   
WHERE  $S_{ds} = 2.10$ ,  $a_p = 1.0$ ,  $I_p = 1.5$ ,  $R_p = 1.5$ ,  $z/h \leq 1$  AT CONCRETE SLAB ON METAL DECK.  
SEE FOLLOWING SHEETS FOR  $\Omega_o$
5. THIS PREAPPROVAL COVERS ONLY THE SUPPORTS AND ATTACHMENTS OF THE EQUIPMENT TO THE STRUCTURE.
6. ALL DESIGN FORCES SHOWN ON THE DRAWINGS ARE FACTORED LOADS THAT SHALL BE USED FOR STRENGTH DESIGN.
7. CONCRETE SLAB ON METAL DECK DETAIL VALID FOR DEMANDS SHOWN AT ANY ELEVATION IN THE BUILDING. (i.e.  $z/h \leq 1$ )
8. CONCRETE SLAB DETAIL VALID FOR DEMANDS SHOWN AT ANY ELEVATION BELOW GRADE. (i.e.  $z/h = 0$ )
9. **RESPONSIBILITIES OF THE STRUCTURAL ENGINEER OF RECORD OF THE BUILDING**
  - A. PROVIDE SUPPORTING STRUCTURE TO SUPPORT WEIGHTS AND FORCES SHOWN IN ADDITION TO ALL OTHER LOADS.
  - B. VERIFY THAT THE INSTALLATION IS IN CONFORMANCE WITH THE 2016 CBC AND WITH THE DETAILS, MATERIAL AND GAGE OF THE UNIT WHERE ATTACHMENTS ARE MADE AGREE WITH THE INFORMATION SHOWN ON THE PREAPPROVAL DOCUMENTS.
  - C. VERIFY THAT PROJECT SPECIFIC VALUES OF  $S_{ds}$  &  $z/h$  RESULT IN SEISMIC FORCES ( $E_h$ ,  $E_v$ ) THAT DO NOT EXCEED THE VALUES ON THE DETAILS.
  - D. VERIFY THAT THE CONCRETE SLAB TO WHICH THE EQUIPMENT IS ANCHORED MEETS THE REQUIREMENTS OF THE APPLICABLE ICC ESR.
  - E. VERIFY THAT THE ANCHORS ARE AN ADEQUATE DISTANCE FROM ANY SLAB EDGES OR OPENINGS (SEE TYPICAL DETAIL ON SHEET 2).
  - F. VERIFY THAT ALL NEW OR EXISTING ANCHORS ARE AN ADEQUATE DISTANCE FROM THE UNIT ATTACHMENTS AND CHECK FOR INTERACTION WHERE OTHER ANCHORS ARE WITHIN 18" OR  $6h_{ef}$  FROM THIS UNIT'S ANCHORS.

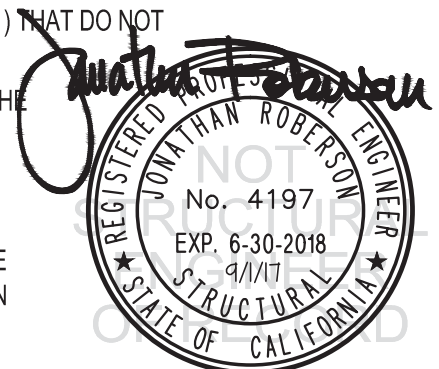

## GETINGE USA

DES. **J. ROBERSON**

SHEET

**2**

JOB NO. **36-1601**

## 88 SERIES WASHER/DISINFECTOR

DATE **9/1/17**

OF **9** SHEETS

### 10. EXPANSION ANCHORS:

A. ATTACHMENT IS TO BE MADE WITH THE ANCHORS LISTED BELOW AND INSTALLED AS DESCRIBED IN THE CORRESPONDING ICC REPORT.

Anchor Diameter	Concrete Type	Min. f'c (psi)	Anchor Type	ICC Report No.	Min. Embed.	Min. Spacing	Min. Edge Dist.	Min. Conc. Thickness	Torque Test	Direct Tension Test
3/8"	Sand Light Weight	3000	Hilti Kwik Bolt TZ	ESR-1917	2"	4"	3"	See Detail "A"	25 FT-LB	N/A
1/2"	Normal Weight	3000	Hilti Kwik Bolt TZ	ESR-1917	2"	5"	18"	4"	40 FT-LB	1471 lb
1/2"	Normal Weight	3000	Hilti Kwik Bolt TZ	ESR-1917	3.25"	5"	18"	6"	40 FT-LB	2514 lb

B. THIS PREAPPROVAL ALLOWS FOR UP TO A MAXIMUM OF 2 ADJACENT CONCRETE SLAB EDGES, 18" AWAY MINIMUM (i.e. - CORNER). SEE ADJACENT DETAIL FOR ADDITIONAL MINIMUM ALLOWABLE CONCRETE EDGE DISTANCES.

C. TESTING OF EXPANSION ANCHORS PER 2016 CBC, 1910A.5: TESTING SHALL BE DONE IN THE PRESENCE OF THE SPECIAL INSPECTOR AND A REPORT OF THE TEST RESULTS SHALL BE SUBMITTED TO OSHPD

(i) AFTER AT LEAST 24 HOURS HAVE ELAPSED SINCE INSTALLATION, DIRECT PULL TENSION TEST OR TORQUE TEST AT LEAST 50% OF THE ANCHORS.

(ii) ACCEPTANCE CRITERIA:

- DIRECT TENSION TEST: THE ANCHOR SHOULD HAVE NO OBSERVABLE MOVEMENT AT THE TEST LOAD. A PRACTICAL WAY TO DETERMINE OBSERVABLE MOVEMENT IS THAT THE WASHER BECOMES LOOSE.
- TORQUE TEST: THE APPLICABLE TORQUE MUST BE ACHIEVED WITHIN THE FOLLOWING LIMITS: WEDGE TYPE : 1/2 TURN OF THE NUT

(iii) IF ANY ANCHOR FAILS, TEST ALL ANCHORS.

D. AVOID DAMAGING EXISTING STEEL REINFORCING IN CONCRETE SLAB WHEN INSTALLING CONCRETE EXPANSION ANCHORS.

E. PROVIDE FOR FULL THREAD ENGAGEMENT OF NUT & WASHER.

### 11. BOLTS THROUGH CONCRETE ON METAL DECK

A. BOLTS SHALL BE TORQUED BY 3/4 TURN OF THE NUTS AFTER THE SNUG TIGHT (THE SNUG-TIGHT CONDITION IS DEFINED AS THE TIGHTNESS REQUIRED TO BRING THE CONNECTED PLIES INTO FIRM CONTACT) CONDITION IS ACHIEVED, UNLESS OTHERWISE NOTED.

B. THROUGH BOLT HOLES SHALL BE 1/16" LARGER THAN BOLT SIZE (HOLE SIZE = BOLT SIZE + 1/16) FOR CONCRETE.

C. THROUGH-BOLTS IN CONCRETE SHALL RECEIVE SPECIAL INSPECTION AND TESTING (THROUGH BOLTS WITH STEEL TO STEEL CONNECTION IN TENSION DO NOT REQUIRE TENSION TESTING) IN ACCORDANCE WITH REQUIREMENTS FOR POST-INSTALLED ANCHORS.

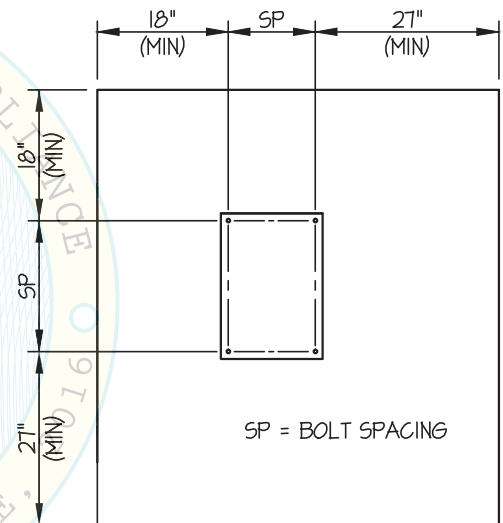

TYPICAL CONCRETE EDGE DETAIL



**GETINGE USA**

DES. **J. ROBERSON**

SHEET

**3**

JOB NO. **36-1601**

OF **9**

SHEETS

**88 SERIES WASHER/DISINFECTOR**

DATE **9/1/17**

SEISMIC SUPPORTS & ATTACHMENTS

CONCRETE SLAB

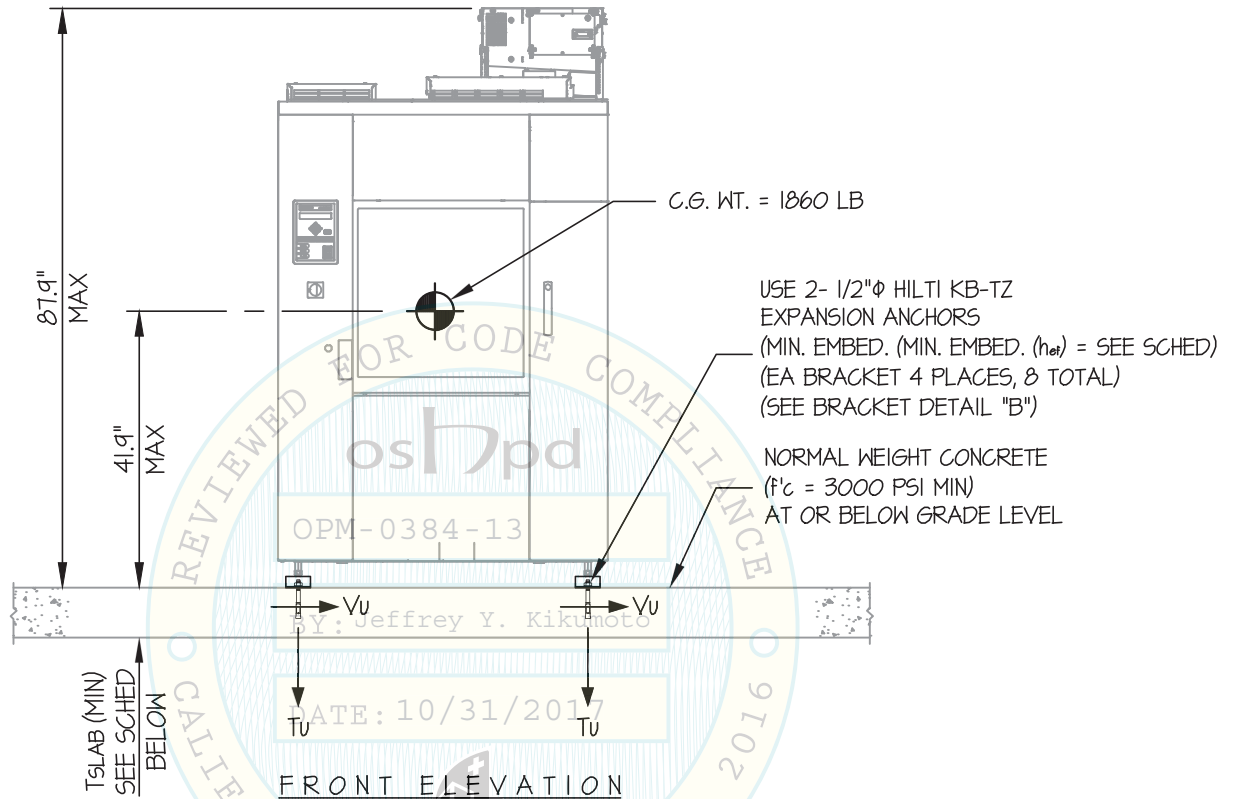

ANCHORS							
MAX Sbs	TYPE	DIAM	EFF EMBED	QTY	T <sub>SLAB</sub>	*T <sub>u</sub> (lb.)	*V <sub>u</sub> (lb.)
180	HILTI KB-TZ	1/2"	2"	8	4"	1084	430
220	HILTI KB-TZ	1/2"	3.25"	8	6"	1384	525

**NOTES:**

\* VALUES INCLUDE  $\Omega_o$

- FORCES ARE DETERMINED PER 2016 CALIFORNIA BUILDING CODE AND ASCE 7-10**  
STRENGTH DESIGN IS USED. ( $\alpha_p = 1.0, I_p = 1.5, R_p = 1.5, \Omega_o = 1.5, z/h = 0$ )
- CENTER OF GRAVITY (C.G.) AND WEIGHT ARE THE GOVERNING PARAMETERS FOR DESIGN. THIS PREAPPROVAL ENCOMPASSES ALL WEIGHTS UP TO THE MAXIMUM WEIGHT SHOWN.
- STRUCTURAL ENGINEER OF RECORD FOR THE BUILDING SHALL PROVIDE SUPPORT STRUCTURE DESIGNED TO SUPPORT WEIGHTS AND FORCES SHOWN IN COMBINATION WITH ALL OTHER LOADS THAT MAY BE PRESENT.
- SEE GENERAL NOTES: SHEET 1 AND 2



**GETINGE USA**

DES. **J. ROBERSON**

SHEET

**4**

**88 SERIES WASHER/DISINFECTOR**

JOB NO. **36-1601**

DATE **9/1/17**

OF **9** SHEETS

SEISMIC SUPPORTS & ATTACHMENTS

MAX Spds  $\leq 1.80$

CONCRETE SLAB

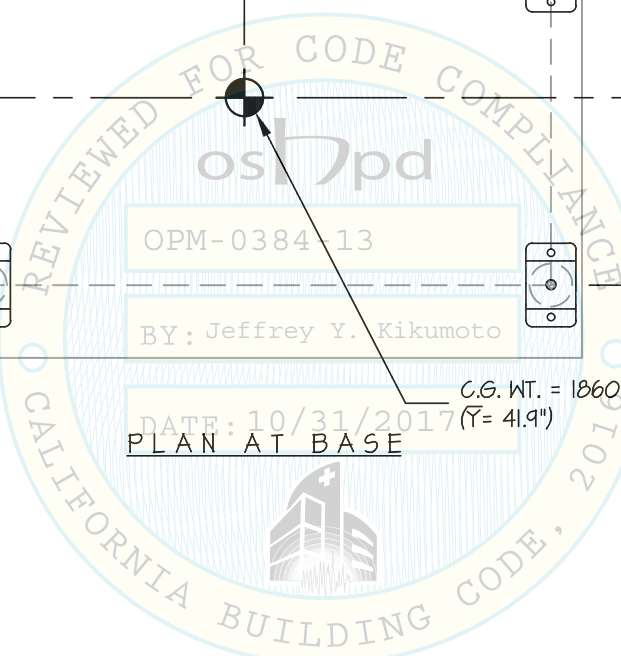
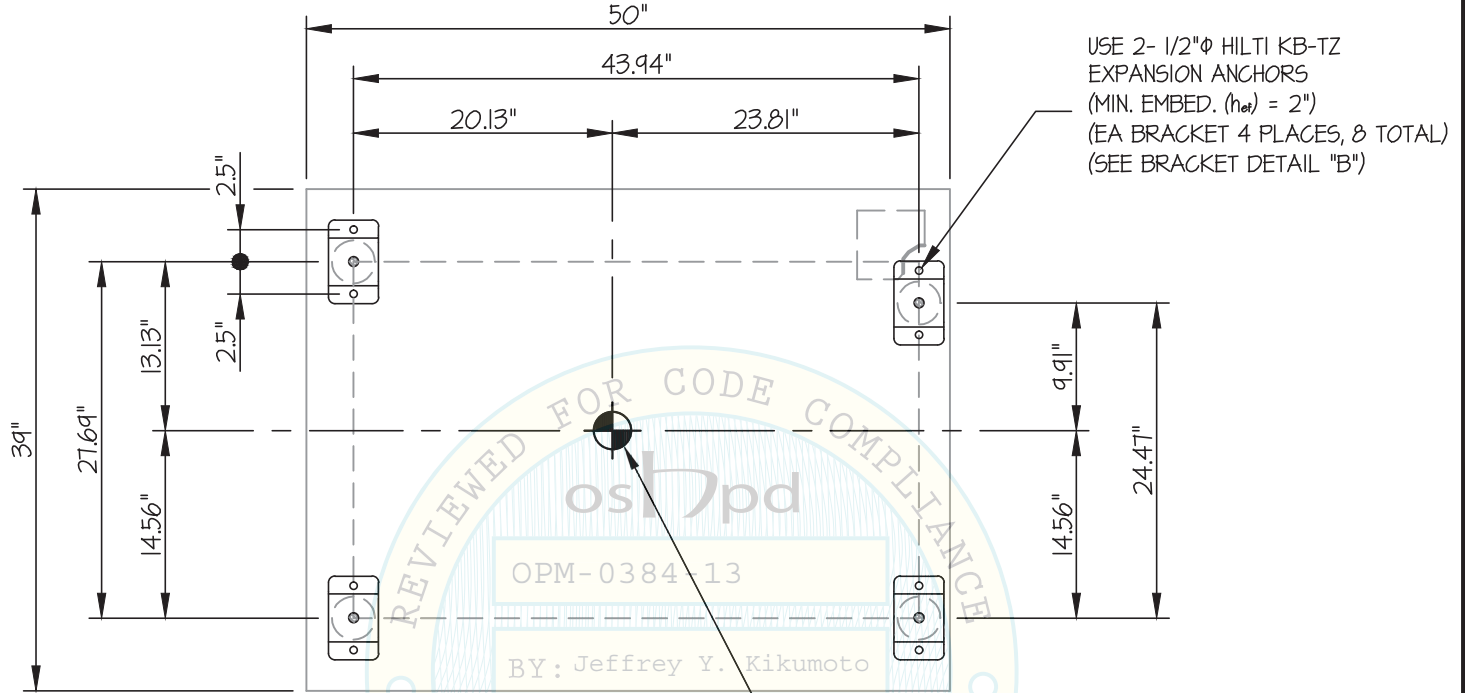

C.G. WT. = 1860 LB  
( $\bar{\gamma}$  = 41.9")  
**PLAN AT BASE**

*Jonathan Roberson*  
REGISTERED PROFESSIONAL ENGINEER  
JONATHAN ROBERSON  
No. 4197  
EXP. 6-30-2018  
9/1/17  
STRUCTURAL  
STATE OF CALIFORNIA

**GETINGE USA**

DES. **J. ROBERSON**

SHEET

**5**

**88 SERIES WASHER/DISINFECTOR**

JOB NO. **36-1601**

DATE **9/1/17**

OF **9** SHEETS

SEISMIC SUPPORTS & ATTACHMENTS

1.80 < MAX S<sub>Ds</sub> ≤ 2.20

CONCRETE SLAB

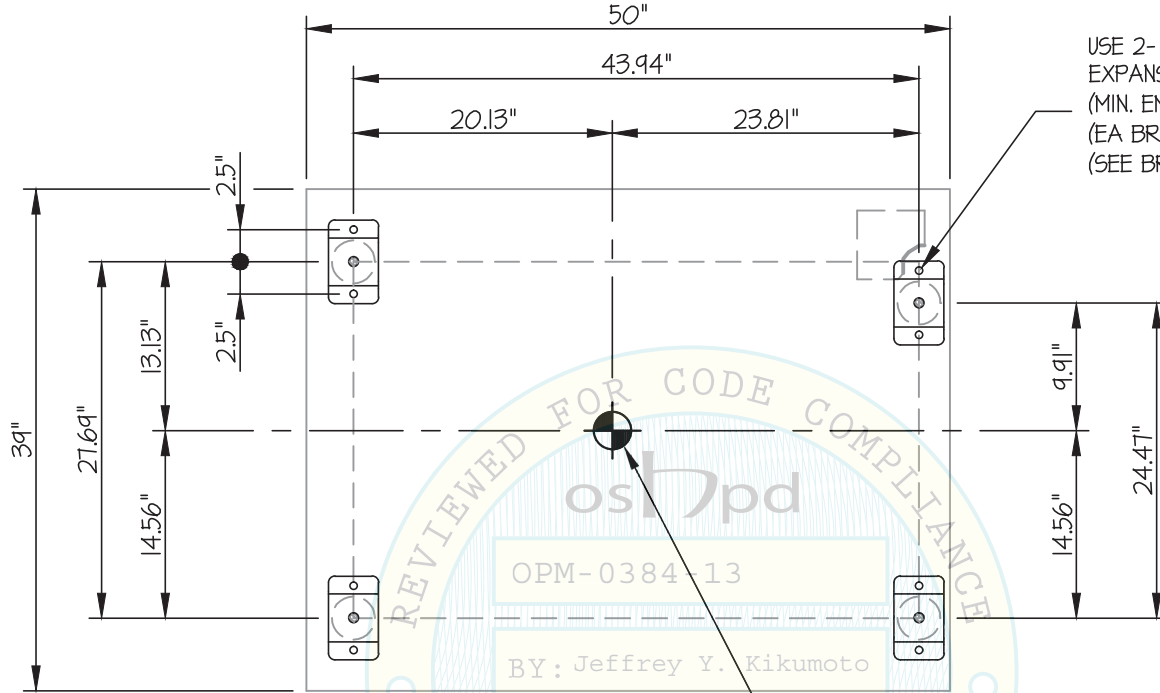

USE 2- 1/2"Ø HILTI KB-TZ  
EXPANSION ANCHORS  
(MIN. EMBED. (h<sub>ef</sub>) = 3.25")  
(EA BRACKET 4 PLACES, 8 TOTAL)  
(SEE BRACKET DETAIL "B")

OPM-0384-13

BY: Jeffrey Y. Kikumoto

C.G. WT. = 1860 LB  
( $\bar{Y}$  = 41.9")  
DATE: 10/31/2017  
**PLAN AT BASE**



### GETINGE USA

DES. **J. ROBERSON**

SHEET

# 6

## 88 SERIES WASHER/DISINFECTOR

JOB NO. **36-1601**

DATE **9/1/17**

OF **9** SHEETS

SEISMIC SUPPORTS & ATTACHMENTS

CONCRETE SLAB ON METAL DECK

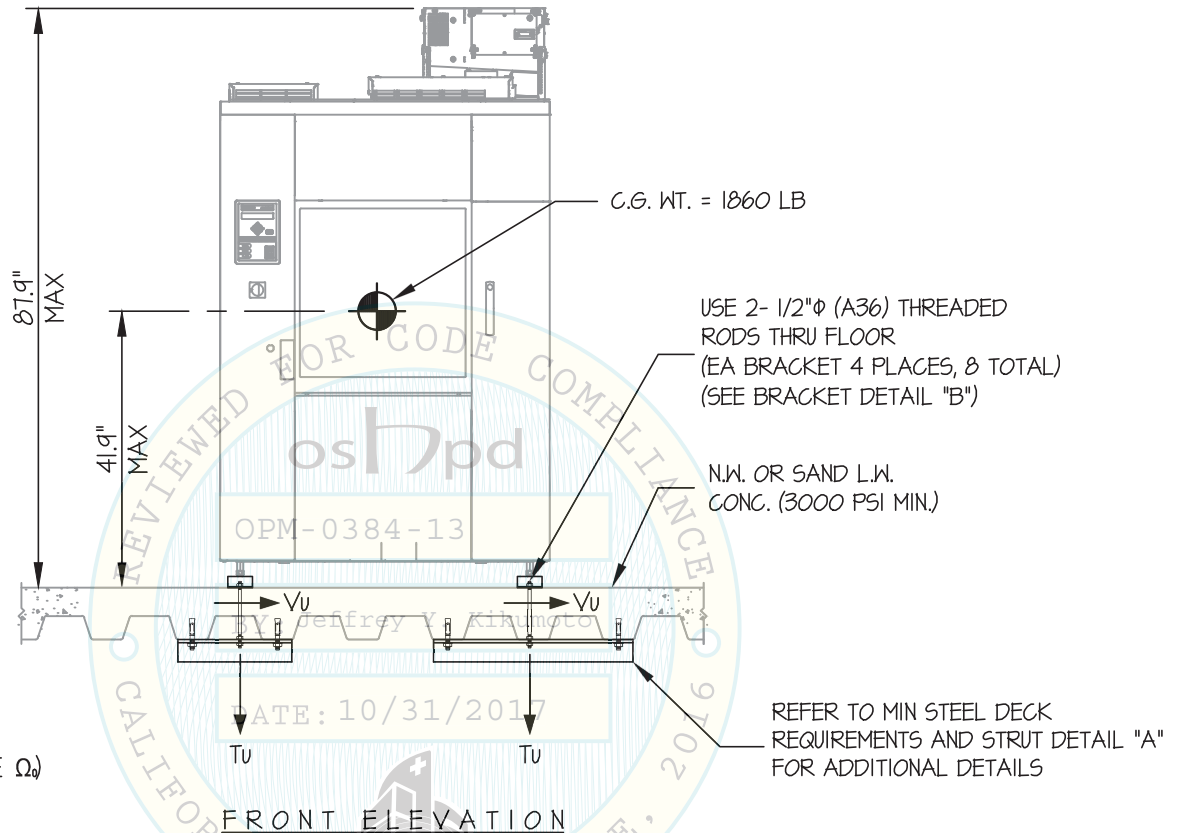

$T_u = 2430$  LB/BOLT (MAX)  
 $V_u = 888$  LB/BOLT (MAX)  
 (VALUES DO NOT INCLUDE  $\Omega$ )

**NOTES:**

- FORCES ARE DETERMINED PER 2016 CALIFORNIA BUILDING CODE AND ASCE 7-10.**  
 STRENGTH DESIGN IS USED. ( $S_{ds} = 2.10$ ,  $a_p = 1.0$ ,  $I_p = 1.5$ ,  $R_p = 1.5$ ,  $\Omega_o = 1.5$ ,  $z/h \leq 1$ )

HORIZONTAL FORCE ( $E_h$ ) =  $2.52 W_p$

HORIZONTAL FORCE ( $E_{mh}$ ) =  $3.78 W_p$  (FOR CONCRETE ANCHORAGE)

VERTICAL FORCE ( $E_v$ ) =  $0.42 W_p$

- CENTER OF GRAVITY (C.G.) AND WEIGHT ARE THE GOVERNING PARAMETERS FOR DESIGN. THIS PREAPPROVAL ENCOMPASSES ALL WEIGHTS UP TO THE MAXIMUM WEIGHT SHOWN.
- STRUCTURAL ENGINEER OF RECORD FOR THE BUILDING SHALL PROVIDE SUPPORT STRUCTURE DESIGNED TO SUPPORT WEIGHTS AND FORCES SHOWN IN COMBINATION WITH ALL OTHER LOADS THAT MAY BE PRESENT.

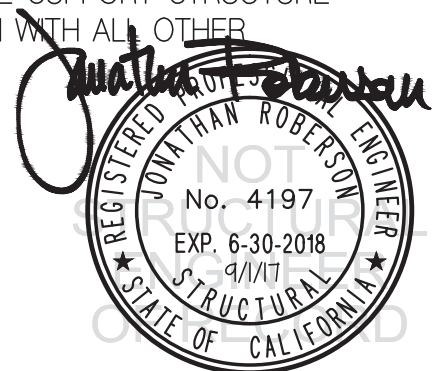



**GETINGE USA**

DES. **J. ROBERSON**

SHEET

**7**

JOB NO. **36-1601**

OF **9**

SHEETS

**88 SERIES WASHER/DISINFECTOR**

DATE **9/1/17**

SEISMIC SUPPORTS & ATTACHMENTS

CONCRETE SLAB ON METAL DECK

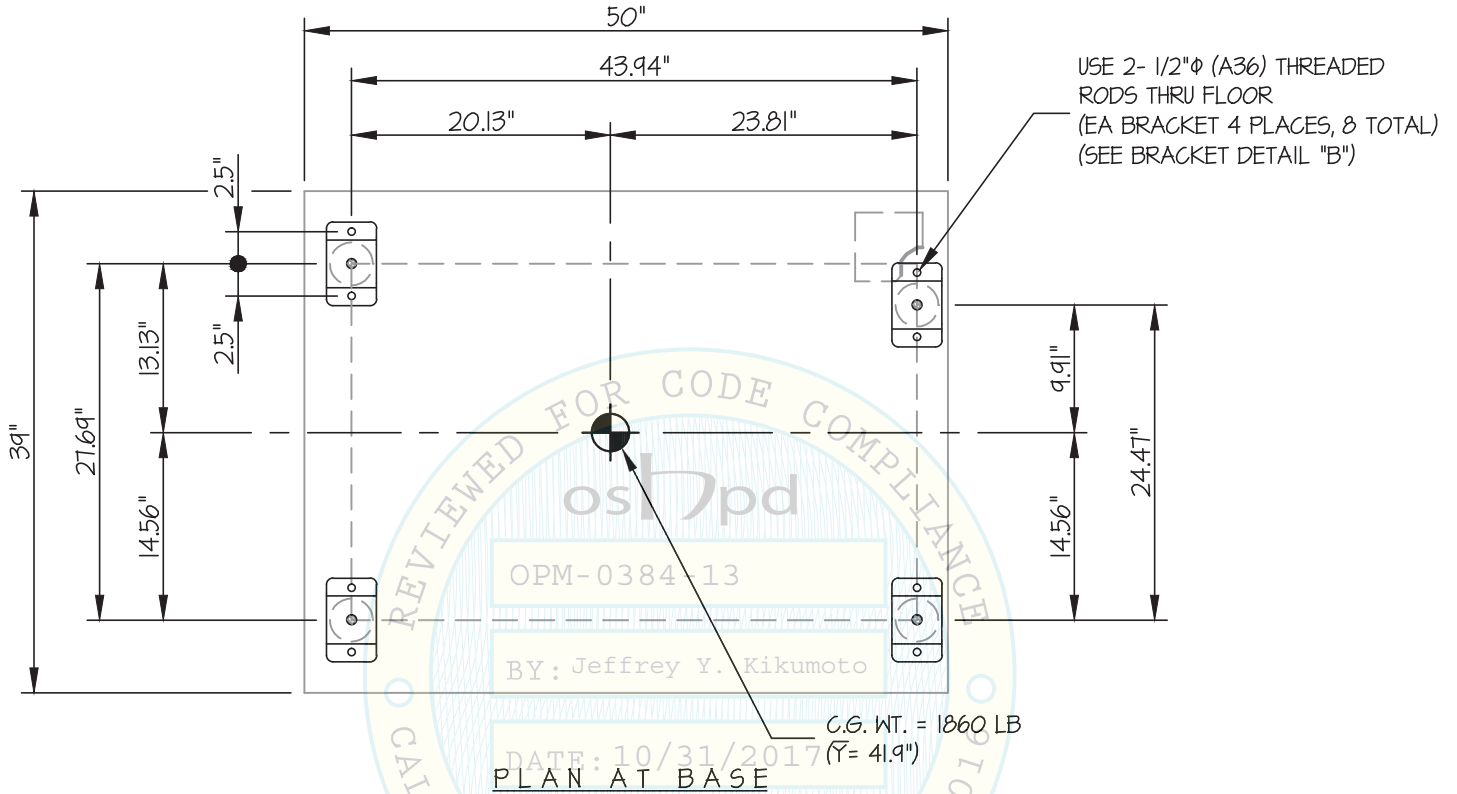

### GETINGE USA

DES. **J. ROBERSON**

SHEET

# 8

JOB NO. **36-1601**

OF

**9** SHEETS

## 88 SERIES WASHER/DISINFECTOR

DATE **9/1/17**

SEISMIC SUPPORTS & ATTACHMENTS

CONCRETE DETAIL

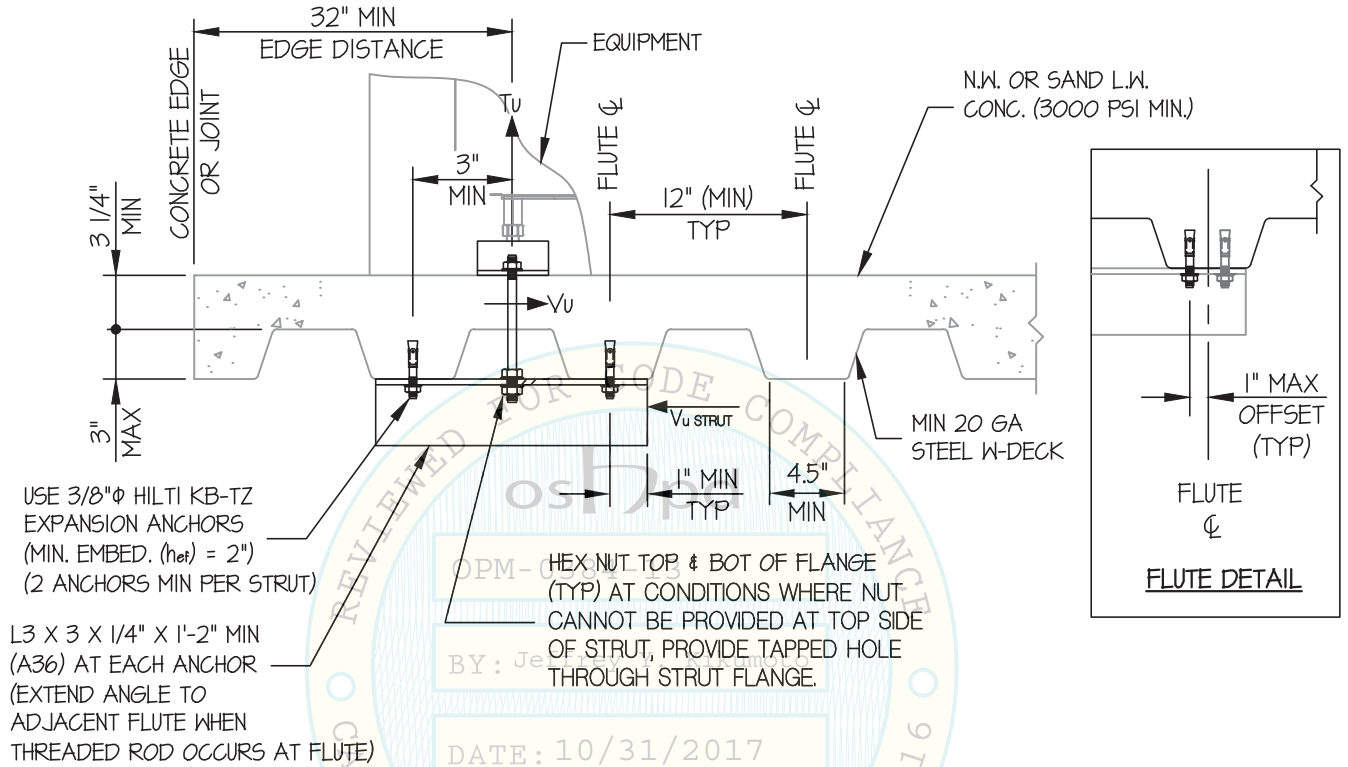

MIN STEEL DECK REQUIREMENTS AND STRUT DETAIL (A)



### GETINGE USA

DES. J. ROBERSON

SHEET

# 9

JOB NO. 36-1601

OF

9 SHEETS

## 88 SERIES WASHER/DISINFECTOR

DATE 9/1/17

SEISMIC SUPPORTS & ATTACHMENTS

BRACKET DETAILS

