



DEPARTMENT OF HEALTH CARE ACCESS AND INFORMATION
FACILITIES DEVELOPMENT DIVISION

APPLICATION FOR HCAI PREAPPROVAL OF
MANUFACTURER'S CERTIFICATION (OPM)

OFFICE USE ONLY

APPLICATION #: OPM-0552

HCAI Preapproval of Manufacturer's Certification (OPM)

Type: New Renewal/Update

Manufacturer Information

Manufacturer: Steris Corporation

Manufacturer's Technical Representative: Wael Abdul-Hadi

Mailing Address: 490 Boul. Armand-Paris, Quebec, QC G1C8A3

Telephone: (418) 664-1549

Email: Wael_Absul-Hadi@steris.com

Product Information

Product Name: ATLAS WAV

Product Type: Other Mechanical or Electrical Component

Product Model Number: N/A

General Description: Single Storage Table Assembly & Double Storage Table Assembly - Racks & Conveyors that are used in Washing/Disinfecting of Medical Equipment

Applicant Information

Applicant Company Name: EASE LLC.

Contact Person: Tiffany Tonn

Mailing Address: 1515 FAIRVIEW AVE, STE 205, MISSOULA, MT 59801

Telephone: (406) 541-3273

Email: tiffany@easeco.com

Title: Office Manager

"A healthier California where all receive equitable, affordable, and quality health care"

STATE OF CALIFORNIA – HEALTH AND HUMAN SERVICES AGENCY





**DEPARTMENT OF HEALTH CARE ACCESS AND INFORMATION
FACILITIES DEVELOPMENT DIVISION**

Registered Design Professional Preparing Engineering Recommendations

Company Name: EASE LLC
Name: Jonathan Roberson California License Number: S4197
Mailing Address: 5877 Pine Ave., Suite 210, Chino Hills, CA 91709
Telephone: (951) 295-1892 Email: jon@EASECo.com

HCAI Special Seismic Certification Preapproval (OSP)

Special Seismic Certification is preapproved under OSP OSP Number: _____

Certification Method

Testing in accordance with: ICC-ES AC156 FM 1950-16
 Other(s) (Please Specify): _____

*Use of criteria other than those adopted by the California Building Standards Code, 2022 (CBSC 2022) for component supports and attachments are not permitted. For distribution system, interior partition wall, and suspended ceiling seismic bracings, test criteria other than those adopted in the CBSC 2022 may be used when approved by HCAI prior to testing.

Analysis
 Experience Data
 Combination of Testing, Analysis, and/or Experience Data (Please Specify): _____

HCAI Approval

Date: 10/23/2023
Name: William Staehlin Title: Senior Structural Engineer
Condition of Approval (if applicable): _____

"A healthier California where all receive equitable, affordable, and quality health care"

STATE OF CALIFORNIA – HEALTH AND HUMAN SERVICES AGENCY





**EQUIPMENT ANCHORAGE
& SEISMIC ENGINEERING**

5877 Pine Ave, Ste. 210
Chino Hills, CA. 91709
Phn: (909) 606-7622

Office of Statewide Health Planning and Development
PREAPPROVAL OF MANUFACTURER'S CERTIFICATION
OPM-0552

THIS PREAPPROVAL CONFORMS TO THE 2022 CALIFORNIA BUILDING CODE

MANUFACTURER: **STERIS CORPORATION**
EQUIPMENT NAME: **SINGLE STORAGE TABLE ASSY / DOUBLE STORAGE TABLE ASSY**

Sheet: 1 of 15
Date: 10/5/23

GENERAL NOTES

1. THIS HCAI PREAPPROVAL OF MANUFACTURER'S CERTIFICATION (OPM) IS BASED ON THE 2022 CBC. THE DEMANDS (DESIGN FORCES) FOR USE WITH THIS OPM SHALL BE BASED ON THE 2022 CBC
2. THIS DOCUMENT MAY ONLY BE USED WITH THE EXPRESS WRITTEN CONSENT OF THE MANUFACTURER LISTED ABOVE FOR THE SPECIFIC PROJECT SITE AND INSTALLATION LOCATION. THIS DOCUMENT IS INVALID WITHOUT SUCH CONSENT.
3. THIS PREAPPROVAL CONFORMS TO THE 2022 CALIFORNIA BUILDING CODE WHERE S_{ds} IS NOT GREATER THAN 1.00 & 2.30. SEE DETAIL FOR APPLICABILITY
4. FORCES PER ASCE 7-16 SECTION 13.3.1, EQUATIONS 13.3-1, 13.3-2 & 13.3-3,
WHERE $S_{ds} = 1.00$, $a_p = 1.0$, $I_p = 1.5$, $R_p = 1.5$, $z/h \leq 1$ AT CONCRETE SLAB ON METAL DECK. SEE FOLLOWING SHEETS FOR Ω_o
WHERE $S_{ds} = 2.30$, $a_p = 1.0$, $I_p = 1.5$, $R_p = 1.5$, $z/h = 0$ AT CONCRETE SLAB. SEE FOLLOWING SHEETS FOR Ω_o
5. THIS PREAPPROVAL COVERS ONLY THE SUPPORTS AND ATTACHMENTS OF THE EQUIPMENT TO THE STRUCTURE.
6. ALL DESIGN FORCES SHOWN ON THE DRAWINGS ARE FACTORED LOADS THAT SHALL BE USED FOR STRENGTH DESIGN.
7. CONCRETE SLAB ON METAL DECK DETAIL VALID FOR DEMANDS SHOWN AT ANY ELEVATION IN THE BUILDING. (i.e. $z/h \leq 1$)
8. CONCRETE SLAB DETAIL VALID FOR DEMANDS SHOWN AT OR BELOW GRADE. (i.e. $z/h = 0$)
9. **RESPONSIBILITIES OF THE STRUCTURAL ENGINEER OF RECORD OF THE BUILDING**
 - A. PROVIDE SUPPORTING STRUCTURE TO SUPPORT WEIGHTS AND FORCES SHOWN IN ADDITION TO ALL OTHER LOADS.
 - B. VERIFY THAT THE INSTALLATION IS IN CONFORMANCE WITH THE 2022 CBC AND WITH THE DETAILS, MATERIAL AND GAGE OF THE UNIT WHERE ATTACHMENTS ARE MADE AGREE WITH THE INFORMATION SHOWN ON THE PREAPPROVAL DOCUMENTS.
 - C. VERIFY THAT PROJECT SPECIFIC VALUES OF S_{ds} & z/h RESULT IN SEISMIC FORCES (E_h , E_v) THAT DO NOT EXCEED THE VALUES ON THE DETAILS.
 - D. VERIFY THAT THE CONCRETE SLAB TO WHICH THE EQUIPMENT IS ANCHORED MEETS THE REQUIREMENTS OF THE APPLICABLE ICC ESR REPORT. AND THIS OPM.
 - E. VERIFY THAT THE ANCHORS ARE AN ADEQUATE DISTANCE FROM ANY SLAB EDGES OR OPENINGS (SEE TYPICAL DETAIL ON SHEET 2).
 - F. VERIFY THAT ALL NEW OR EXISTING ANCHORS ARE AN ADEQUATE DISTANCE FROM THE UNIT ATTACHMENTS AND CHECK FOR INTERACTION WHERE OTHER ANCHORS ARE WITHIN 18" OR $6h_{ef}$ FROM THIS UNIT'S ANCHORS.



STERIS CORPORATION

DES. **J. ROBERSON**

SHEET

2

JOB NO. **14-2307**

ATLAS WAW SINGLE / DOUBLE STORAGE TABLE ASSY

DATE **10/5/23**

OF **15** SHEETS

10. EXPANSION ANCHORS:

- A. ATTACHMENT IS TO BE MADE WITH THE ANCHORS LISTED BELOW AND INSTALLED AS DESCRIBED IN THE CORRESPONDING ICC REPORT.

Anchor Diameter	Concrete Type	Min. f'c (psi)	Anchor Type	ICC Report No.	Eff. Embed.	Min. Spacing	Min. Edge Dist.	Min. Conc. Thickness	Torque Test	Direct Tension Test
3/8"	Normal Weight	3000	Hilti Kwik Bolt TZ2 (STAINLESS STEEL)	ESR-4266	2"	3"	18"	4"	30 FT-LB	1486 lb
3/8"	Sand Light Weight	3000	Simpson Strong Bolt 2 (STAINLESS STEEL)	ESR-3037	1.5"	3"	12"	3.25"	30 FT-LB	590 lb

- B. THIS PREAPPROVAL ALLOWS FOR UP TO A MAXIMUM OF 2 ADJACENT CONCRETE SLAB EDGES, 12" & 18" AWAY MINIMUM (i.e. - CORNER). SEE ADJACENT DETAIL FOR ADDITIONAL MINIMUM ALLOWABLE CONCRETE EDGE DISTANCES.

- C. TESTING AND SPECIAL INSPECTION OF EXPANSION ANCHORS SHALL BE PERFORMED BY AN APPROVED INDEPENDENT AGENCY EMPLOYED BY THE FACILITY OWNER PER CBC 1704A & 1910A.5 AND CAC 7-149. ALL REPORTS SHALL BE SENT TO THE INSPECTOR OF RECORD, OWNER AND THE ARCHITECT OR ENGINEER IN RESPONSIBLE CHARGE.

- (i) AFTER AT LEAST 24 HOURS HAVE ELAPSED SINCE INSTALLATION, DIRECT PULL TENSION TEST OR TORQUE TEST AT LEAST 50% OF THE ANCHORS.
- (ii) ACCEPTANCE CRITERIA:
- DIRECT TENSION TEST: THE ANCHOR SHOULD HAVE NO OBSERVABLE MOVEMENT AT THE TEST LOAD. A PRACTICAL WAY TO DETERMINE OBSERVABLE MOVEMENT IS THAT THE WASHER BECOMES LOOSE.
 - TORQUE TEST: THE APPLICABLE TORQUE MUST BE ACHIEVED WITHIN THE FOLLOWING LIMITS: WEDGE TYPE : 1/2 TURN OF THE NUT

- (iii) IF ANY ANCHOR FAILS, TEST ALL ANCHORS.

- D. AVOID DAMAGING EXISTING STEEL REINFORCING IN CONCRETE SLAB WHEN INSTALLING CONCRETE EXPANSION ANCHORS.

- E. PROVIDE FOR FULL THREAD ENGAGEMENT OF NUT & WASHER.

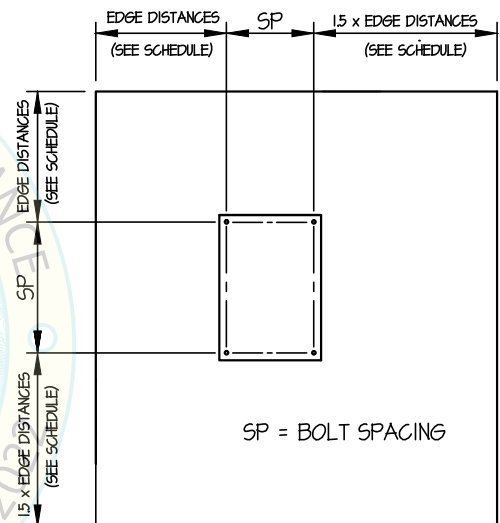

TYPICAL CONCRETE EDGE DETAIL



STERIS CORPORATION

ATLAS WAV SINGLE STORAGE TABLE ASSY W/ TWO LOADED RACKS

DES. J. ROBERSON

JOB NO. 14-2307

DATE 10/5/23

SHEET

3

OF 15 SHEETS

SEISMIC SUPPORTS & ATTACHMENTS

CONCRETE SLAB

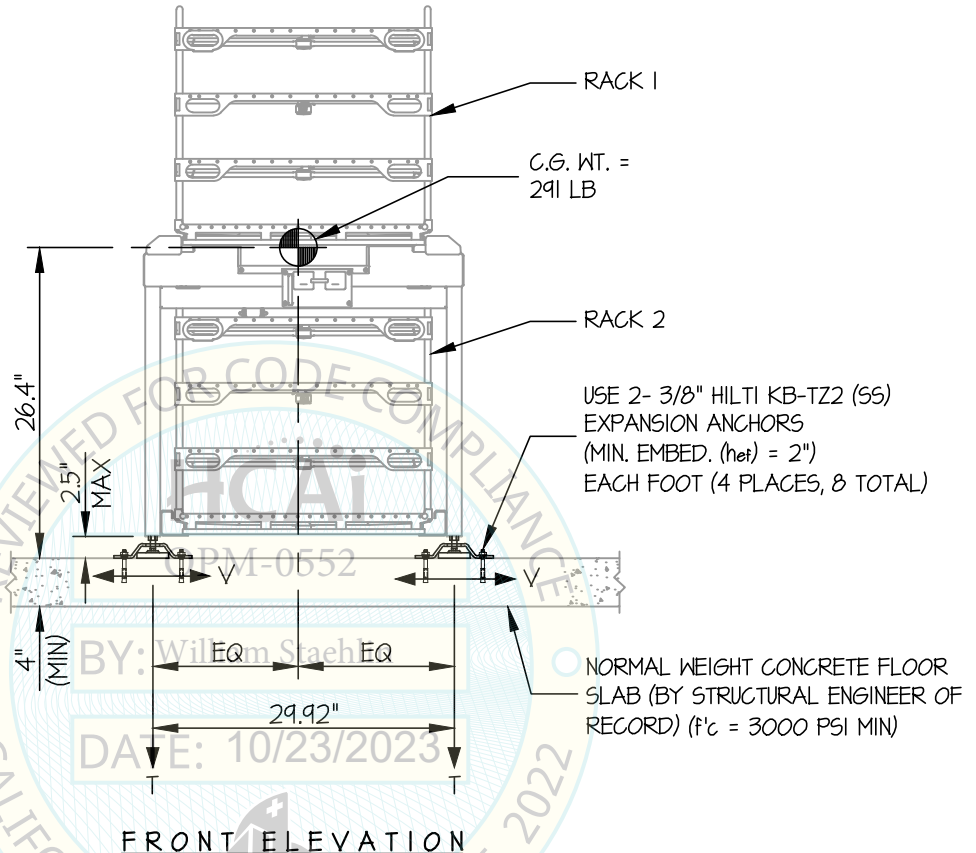

T_U = 171 LB/BOLT (MAX)
V_U = 98 LB/BOLT (MAX)
(VALUES INCLUDE Ω)

NOTES:

- FORCES ARE DETERMINED PER 2022 CALIFORNIA BUILDING CODE AND ASCE 7-16. STRENGTH DESIGN IS USED. (EXAMPLE: S_{Ds} = 2.30, α_p = 1.0, I_p = 1.5, R_p = 1.5, Ω_o = 2.0, z/h = 0)

$$\text{HORIZONTAL FORCE (E}_h\text{)} = 1.035 W_p$$

$$\text{HORIZONTAL FORCE (E}_{mh}\text{)} = 2.07 W_p \text{ (FOR CONCRETE ANCHORAGE)}$$

$$\text{VERTICAL FORCE (E}_v\text{)} = 0.46 W_p$$

- THIS PREAPPROVAL ENCOMPASSES WEIGHTS AND VERTICAL CG POSITIONS UP TO THE VALUES SHOWN.
- THIS PREAPPROVAL WAS PREPARED WITHOUT KNOWLEDGE OF ANY SITE CONDITION. COMPATIBILITY FOR USE WITH A SITE SHALL BE EVALUATED BY THE STRUCTURAL ENGINEER OF RECORD OF THE INSTALLATION (SEOR). USE REQUIRES APPROVAL BY THE SEOR.
- STRUCTURAL ENGINEER OF RECORD FOR THE INSTALLATION SHALL VERIFY ALL CONDITIONS, EVALUATE INTERACTION WITH ADJACENT EQUIPMENT AND ANCHORS, AND PROVIDE SUPPORT STRUCTURE DESIGNED TO SUPPORT WEIGHTS AND FORCES SHOWN IN COMBINATION WITH ALL OTHER LOADS THAT MAY BE PRESENT.
- SEE GENERAL NOTES: SHEETS 1 AND 2



STERIS CORPORATION

**ATLAS WAV
SINGLE STORAGE TABLE ASSY
W/ TWO LOADED RACKS**

DES. **J. ROBERSON**

JOB NO. **14-2307**

DATE **10/5/23**

SHEET

4

OF **15** SHEETS

SEISMIC SUPPORTS & ATTACHMENTS

CONCRETE SLAB

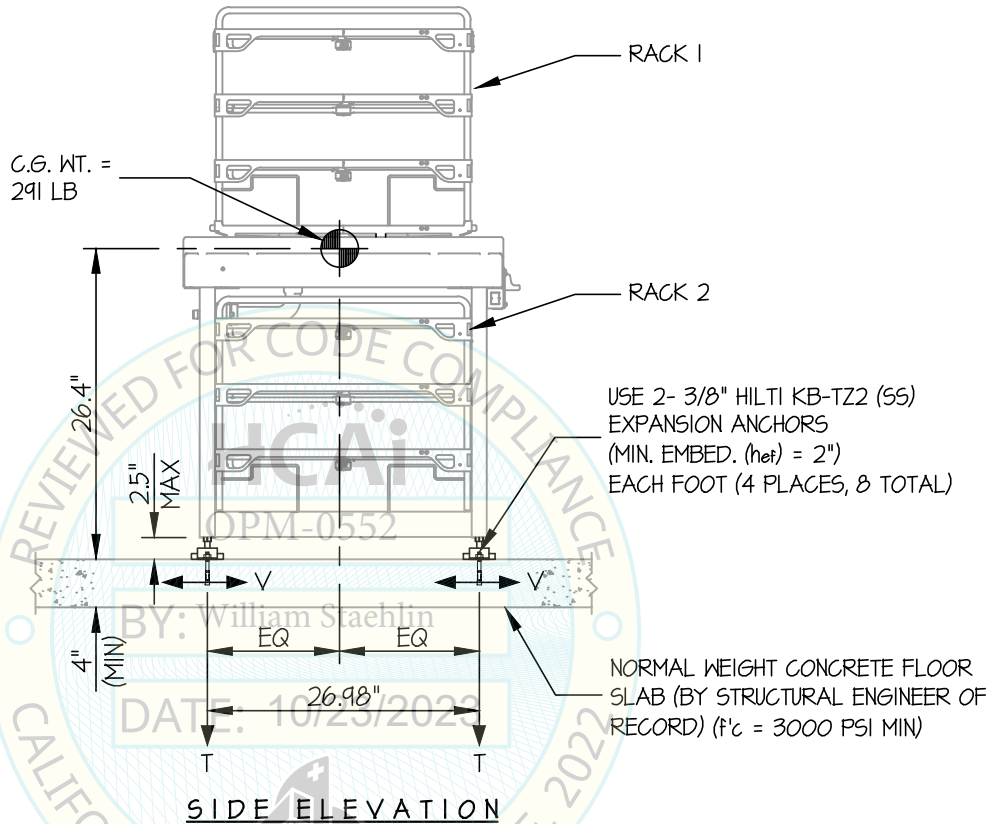

Jonathan Roberson

REGISTERED PROFESSIONAL ENGINEER
JONATHAN ROBERSON
No. 4197
EXP. 6-30-2024
10/5/23
STRUCTURAL
STATE OF CALIFORNIA

STERIS CORPORATION

DES. J. ROBERSON

SHEET

5

JOB NO. 14-2307

DATE 10/5/23

OF 15 SHEETS

ATLAS WAV DOUBLE STORAGE TABLE ASSY W/ TWO LOADED (TOP) & ONE EMPTY (BOTTOM)

SEISMIC SUPPORTS & ATTACHMENTS

CONCRETE SLAB

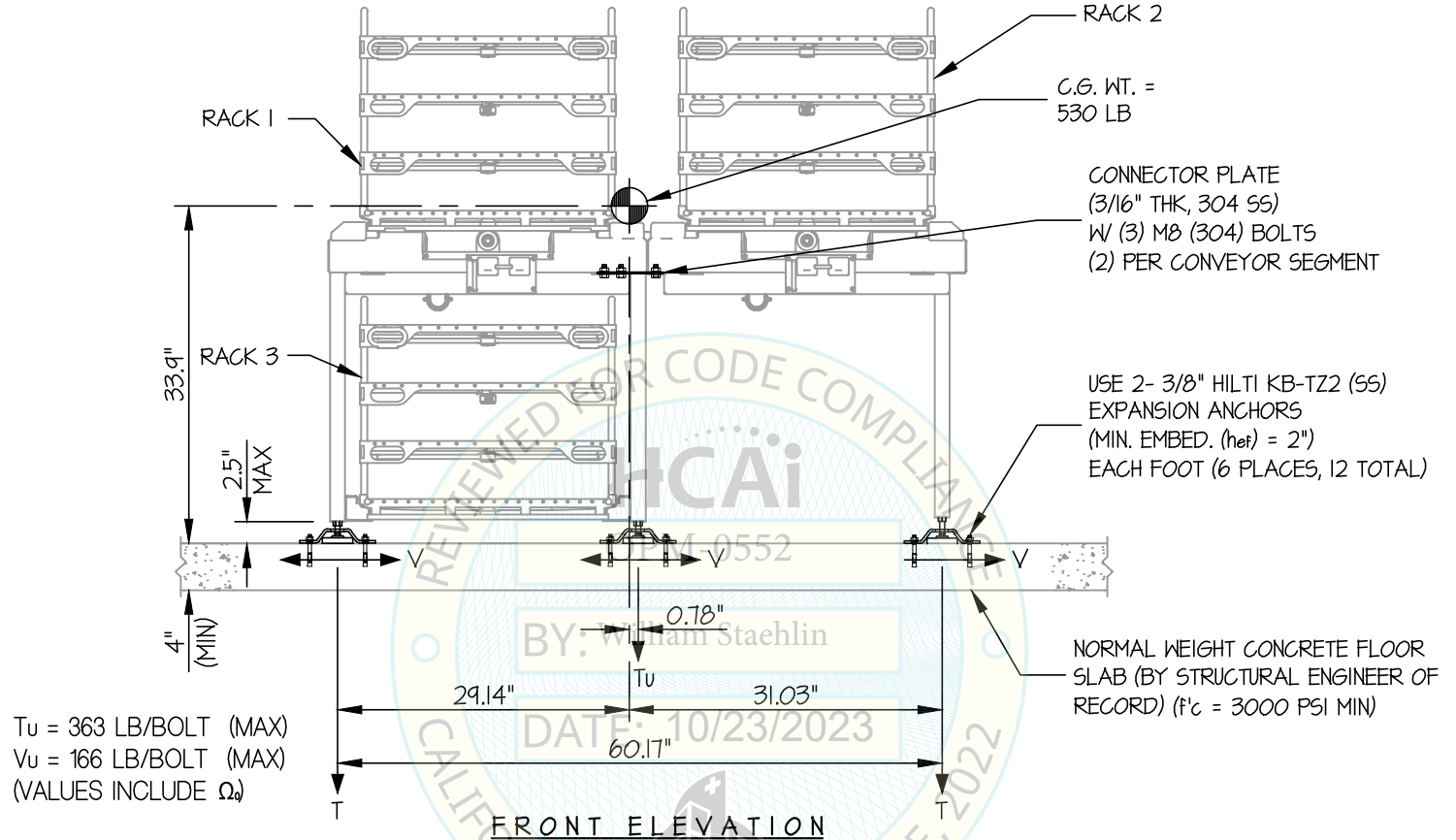

NOTES:

- FORCES ARE DETERMINED PER 2022 CALIFORNIA BUILDING CODE AND ASCE 7-16. STRENGTH DESIGN IS USED. (EXAMPLE: S_{ds} = 2.30, α_p = 10, I_p = 15, R_p = 15, Ω_o = 2.0, z/h = 0)

HORIZONTAL FORCE (E_h) = 1.035 W_p
 HORIZONTAL FORCE (E_{mh}) = 2.07 W_p (FOR CONCRETE ANCHORAGE)
 VERTICAL FORCE (E_v) = 0.46 W_p

- THIS PREAPPROVAL ENCOMPASSES WEIGHTS AND VERTICAL CG POSITIONS UP TO THE VALUES SHOWN.
- THIS PREAPPROVAL WAS PREPARED WITHOUT KNOWLEDGE OF ANY SITE CONDITION. COMPATIBILITY FOR USE WITH A SITE SHALL BE EVALUATED BY THE STRUCTURAL ENGINEER OF RECORD OF THE INSTALLATION (SEOR). USE REQUIRES APPROVAL BY THE SEOR.
- STRUCTURAL ENGINEER OF RECORD FOR THE INSTALLATION SHALL VERIFY ALL CONDITIONS, EVALUATE INTERACTION WITH ADJACENT EQUIPMENT AND ANCHORS, AND PROVIDE SUPPORT STRUCTURE DESIGNED TO SUPPORT WEIGHTS AND FORCES SHOWN IN COMBINATION WITH ALL OTHER LOADS THAT MAY BE PRESENT.
- SEE GENERAL NOTES: SHEETS 1 AND 2



STERIS CORPORATION

DES. **J. ROBERSON**

SHEET

6

**ATLAS WAV
DOUBLE STORAGE TABLE ASSY
W/ TWO LOADED (TOP) & ONE EMPTY (BOTTOM)**

JOB NO. **14-2307**

DATE **10/5/23**

OF **15** SHEETS

SEISMIC SUPPORTS & ATTACHMENTS

CONCRETE SLAB

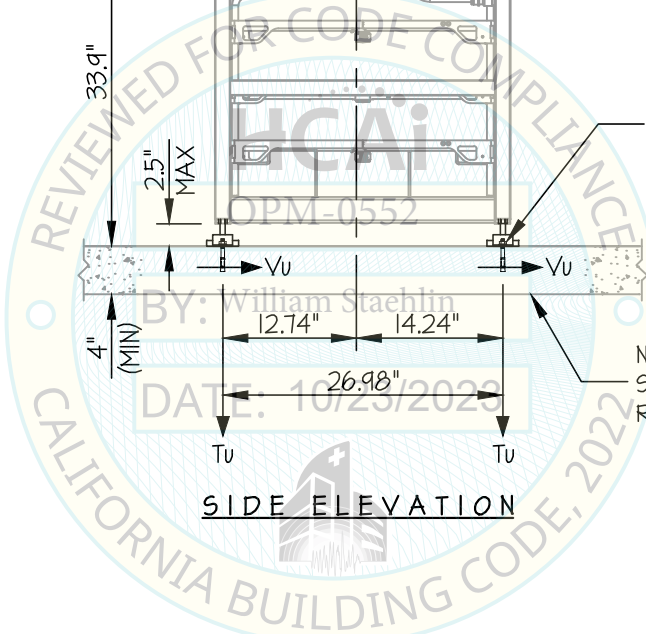
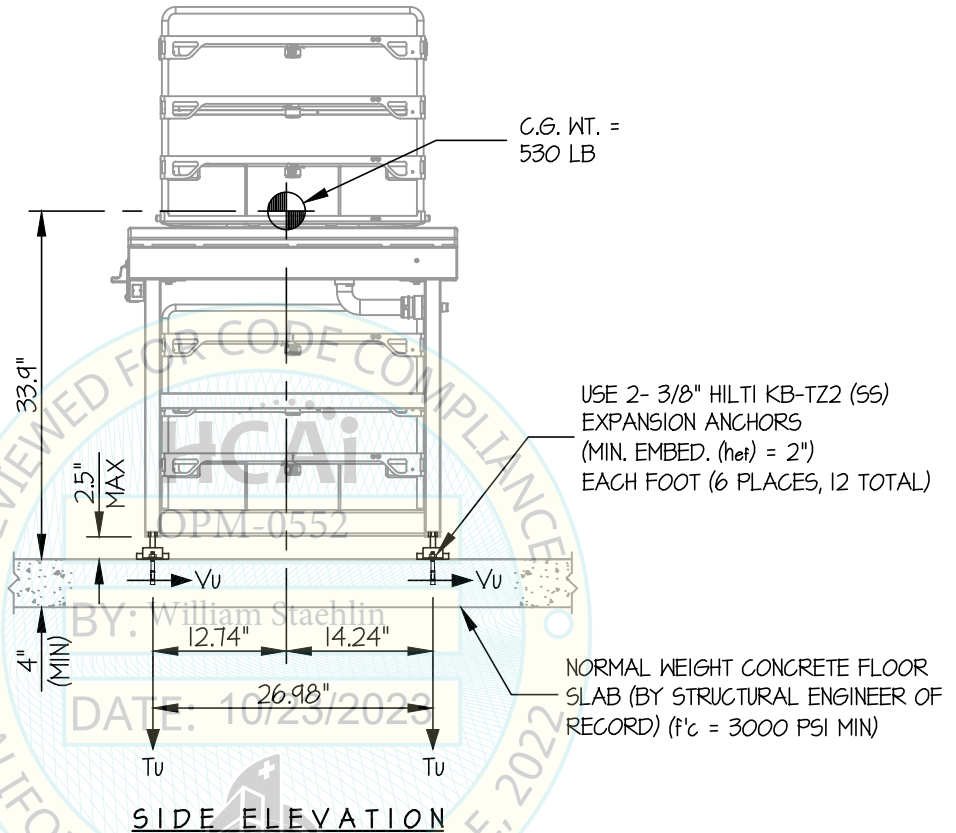

Jonathan Roberson

REGISTERED PROFESSIONAL ENGINEER
JONATHAN ROBERSON
No. 4197
EXP. 6-30-2024
10/5/23
STRUCTURAL
STATE OF CALIFORNIA

STERIS CORPORATION

DES. **J. ROBERSON**

SHEET

7

JOB NO. **14-2307**

ATLAS WAV DOUBLE STORAGE TABLE ASSY (EMPTY)

DATE **10/5/23**

OF **15** SHEETS

SEISMIC SUPPORTS & ATTACHMENTS

CONCRETE SLAB

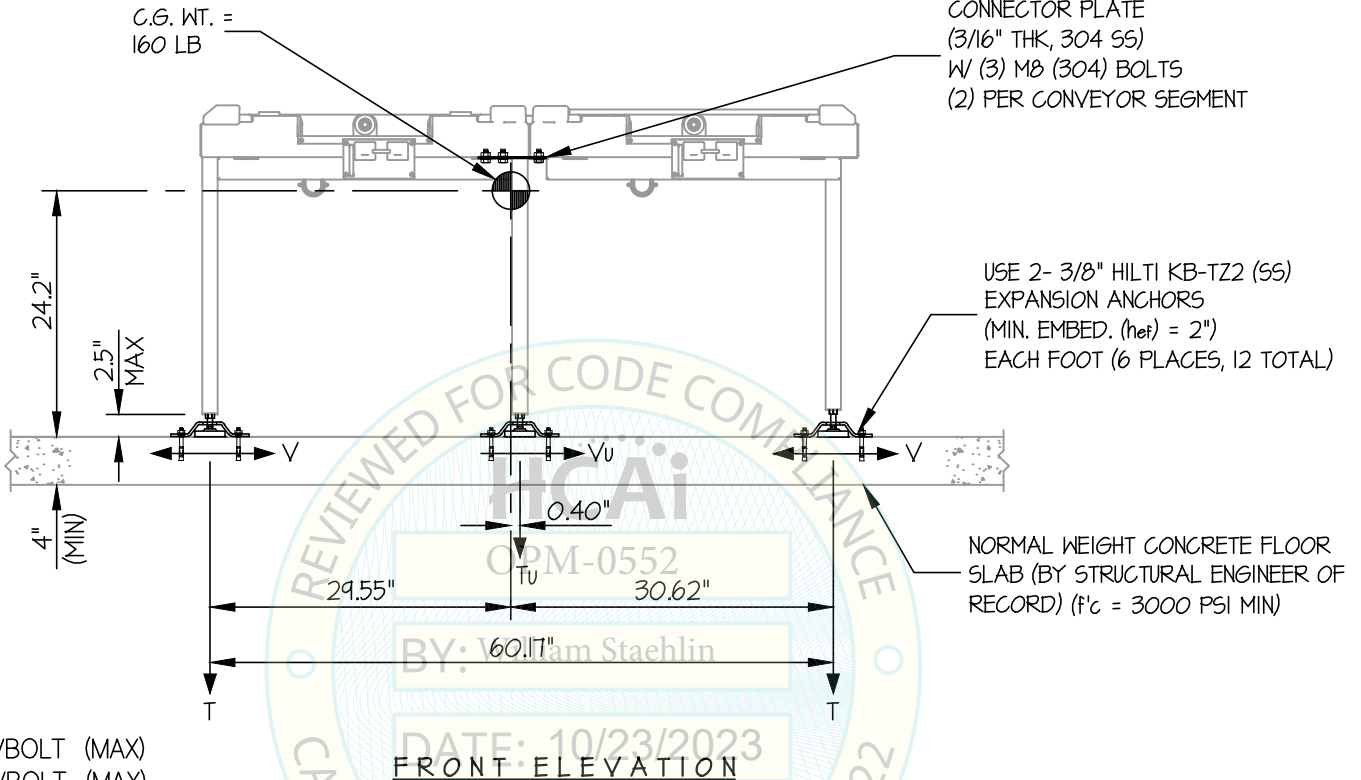

Tu = 75 LB/BOLT (MAX)
Vu = 50 LB/BOLT (MAX)
(VALUES INCLUDE Ω_o)

NOTES:

- FORCES ARE DETERMINED PER 2022 CALIFORNIA BUILDING CODE AND ASCE 7-16. STRENGTH DESIGN IS USED. (EXAMPLE: Sds = 2.30, αp = 1.0, lp = 1.5, Rp = 1.5, Ωo = 2.0, z/h = 0)

HORIZONTAL FORCE (Eh) = 1.035 Wp
 HORIZONTAL FORCE (Emh) = 2.07 Wp (FOR CONCRETE ANCHORAGE)
 VERTICAL FORCE (Ev) = 0.46 Wp

- THIS PREAPPROVAL ENCOMPASSES WEIGHTS AND VERTICAL CG POSITIONS UP TO THE VALUES SHOWN.
- THIS PREAPPROVAL WAS PREPARED WITHOUT KNOWLEDGE OF ANY SITE CONDITION. COMPATIBILITY FOR USE WITH A SITE SHALL BE EVALUATED BY THE STRUCTURAL ENGINEER OF RECORD OF THE INSTALLATION (SEOR). USE REQUIRES APPROVAL BY THE SEOR.
- STRUCTURAL ENGINEER OF RECORD FOR THE INSTALLATION SHALL VERIFY ALL CONDITIONS, EVALUATE INTERACTION WITH ADJACENT EQUIPMENT AND ANCHORS, AND PROVIDE SUPPORT STRUCTURE DESIGNED TO SUPPORT WEIGHTS AND FORCES SHOWN IN COMBINATION WITH ALL OTHER LOADS THAT MAY BE PRESENT.
- SEE GENERAL NOTES: SHEETS 1 AND 2

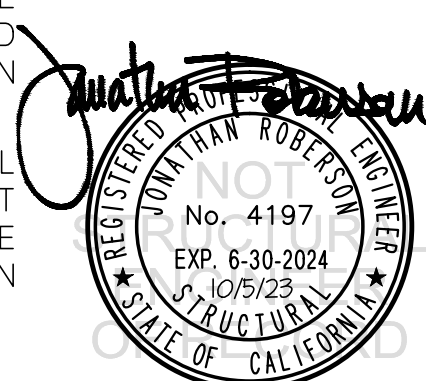

STERIS CORPORATION

DES. J. ROBERSON

SHEET

8

JOB NO. 14-2307

ATLAS WAV
DOUBLE STORAGE TABLE ASSY (EMPTY)

DATE 10/5/23

OF 15 SHEETS

SEISMIC SUPPORTS & ATTACHMENTS

CONCRETE SLAB

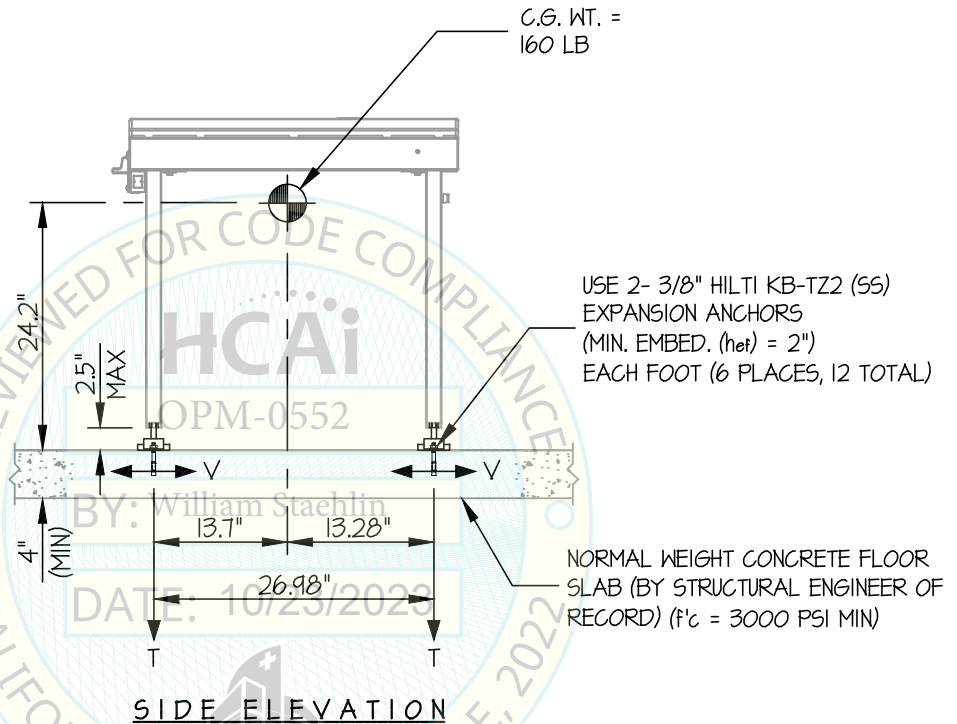

Jonathan Roberson

REGISTERED PROFESSIONAL ENGINEER
JONATHAN ROBERSON
No. 4197
EXP. 6-30-2024
10/5/23
STRUCTURAL
STATE OF CALIFORNIA

STERIS CORPORATION

DES. J. ROBERSON

SHEET

9

ATLAS WAV SINGLE STORAGE TABLE ASSY W/ TWO LOADED RACKS

JOB NO. 14-2307

DATE 10/5/23

OF 15 SHEETS

SEISMIC SUPPORTS & ATTACHMENTS

CONCRETE SLAB ON METAL DECK

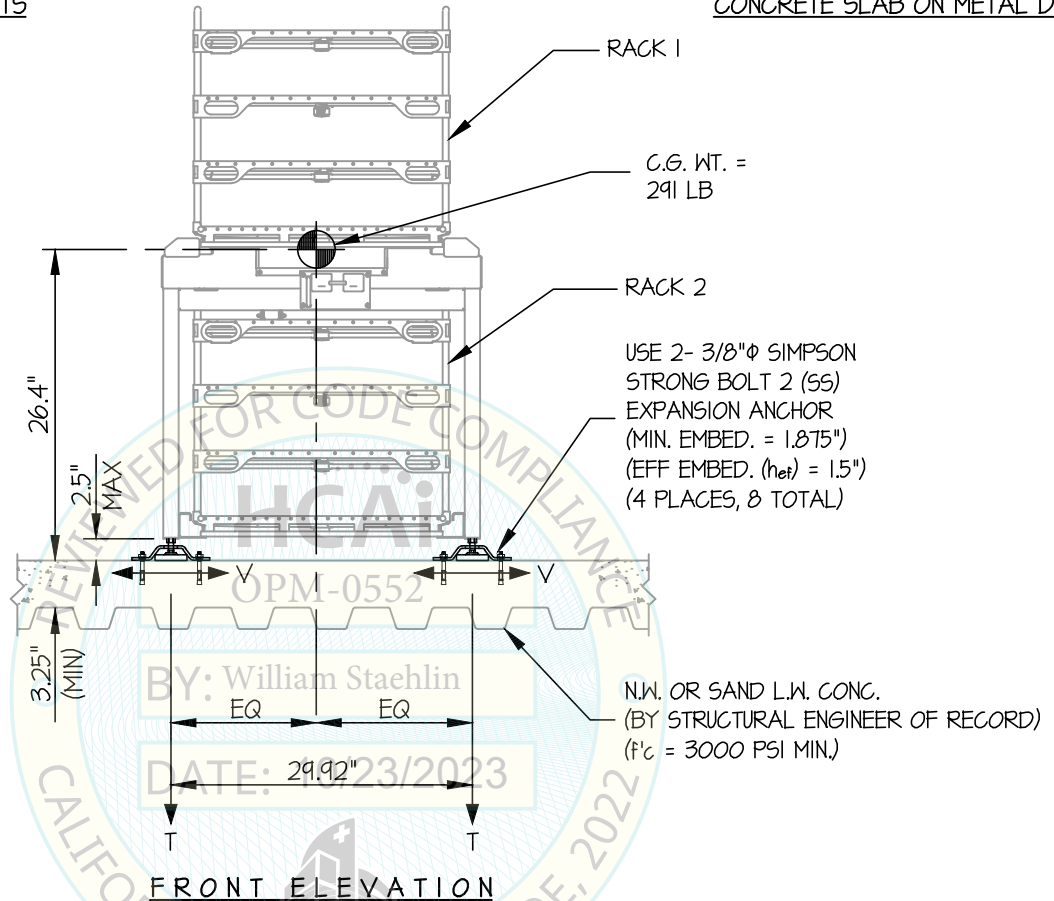

T_u = 192 LB/BOLT (MAX)
 V_u = 113 LB/BOLT (MAX)
 (VALUES INCLUDE Ω_d)

NOTES:

- FORCES ARE DETERMINED PER 2022 CALIFORNIA BUILDING CODE AND ASCE 7-16. STRENGTH DESIGN IS USED. (EXAMPLE: $S_{ps} = 1.00$, $a_p = 1.0$, $l_p = 15$, $R_p = 15$, $\Omega_o = 2.0$, $z/h \leq 1$)
 - HORIZONTAL FORCE (E_h) = $1.20 W_p$
 - HORIZONTAL FORCE (E_{mh}) = $2.40 W_p$ (FOR CONCRETE ANCHORAGE)
 - VERTICAL FORCE (E_v) = $0.20 W_p$
- THIS PREAPPROVAL ENCOMPASSES WEIGHTS AND VERTICAL CG POSITIONS UP TO THE VALUES SHOWN.
- THIS PREAPPROVAL WAS PREPARED WITHOUT KNOWLEDGE OF ANY SITE CONDITION. COMPATIBILITY FOR USE WITH A SITE SHALL BE EVALUATED BY THE STRUCTURAL ENGINEER OF RECORD OF THE INSTALLATION (SEOR). USE REQUIRES APPROVAL BY THE SEOR.
- STRUCTURAL ENGINEER OF RECORD FOR THE INSTALLATION SHALL VERIFY ALL CONDITIONS, EVALUATE INTERACTION WITH ADJACENT EQUIPMENT AND ANCHORS, AND PROVIDE SUPPORT STRUCTURE DESIGNED TO SUPPORT WEIGHTS AND FORCES SHOWN IN COMBINATION WITH ALL OTHER LOADS THAT MAY BE PRESENT.
- SEE GENERAL NOTES: SHEETS 1 AND 2



STERIS CORPORATION

**ATLAS WAV
SINGLE STORAGE TABLE ASSY
W/ TWO LOADED RACKS**

DES. **J. ROBERSON**

JOB NO. **14-2307**

DATE **10/5/23**

SHEET

10

OF **15** SHEETS

SEISMIC SUPPORTS & ATTACHMENTS

CONCRETE SLAB ON METAL DECK

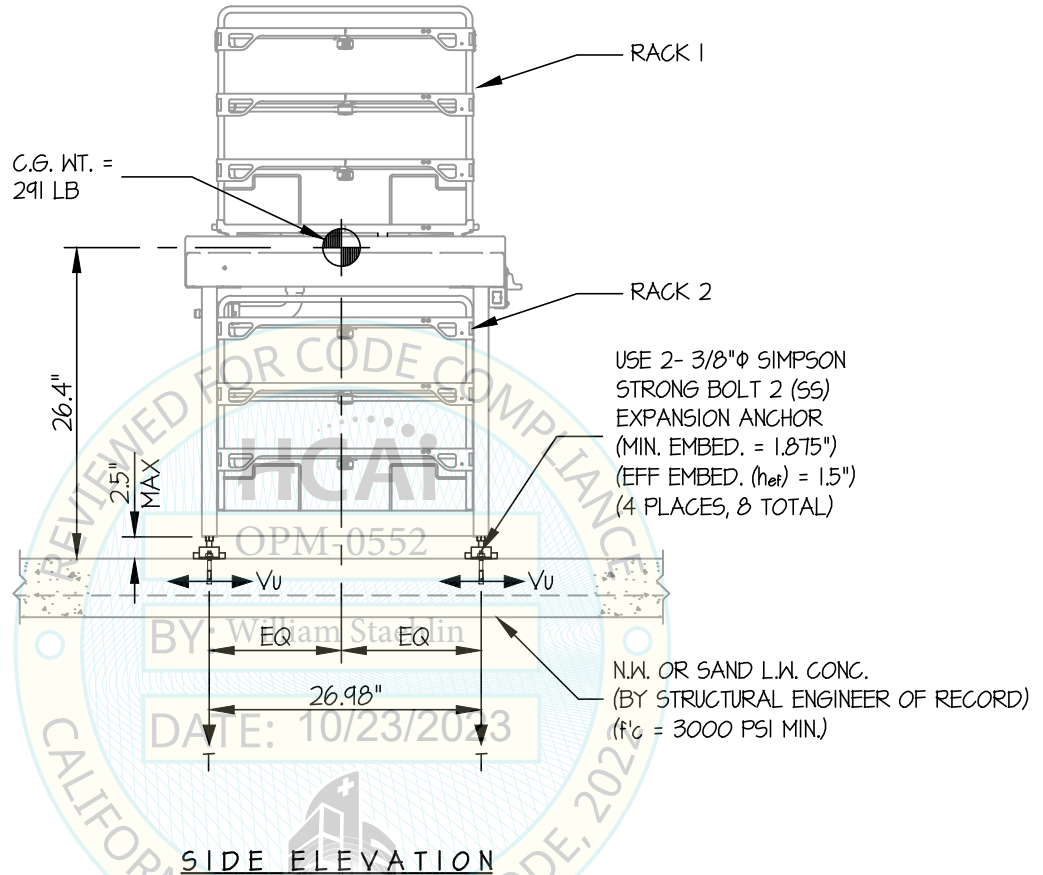

Jonathan Roberson

REGISTERED PROFESSIONAL ENGINEER
JONATHAN ROBERSON
No. 4197
EXP. 6-30-2024
10/5/23
STRUCTURAL
STATE OF CALIFORNIA

STERIS CORPORATION

DES. J. ROBERSON

SHEET

11

JOB NO. 14-2307

DATE 10/5/23

OF 15 SHEETS

ATLAS WAV DOUBLE STORAGE TABLE ASSY W/ TWO LOADED (TOP) & ONE EMPTY (BOTTOM)

SEISMIC SUPPORTS & ATTACHMENTS

CONCRETE SLAB ON METAL DECK

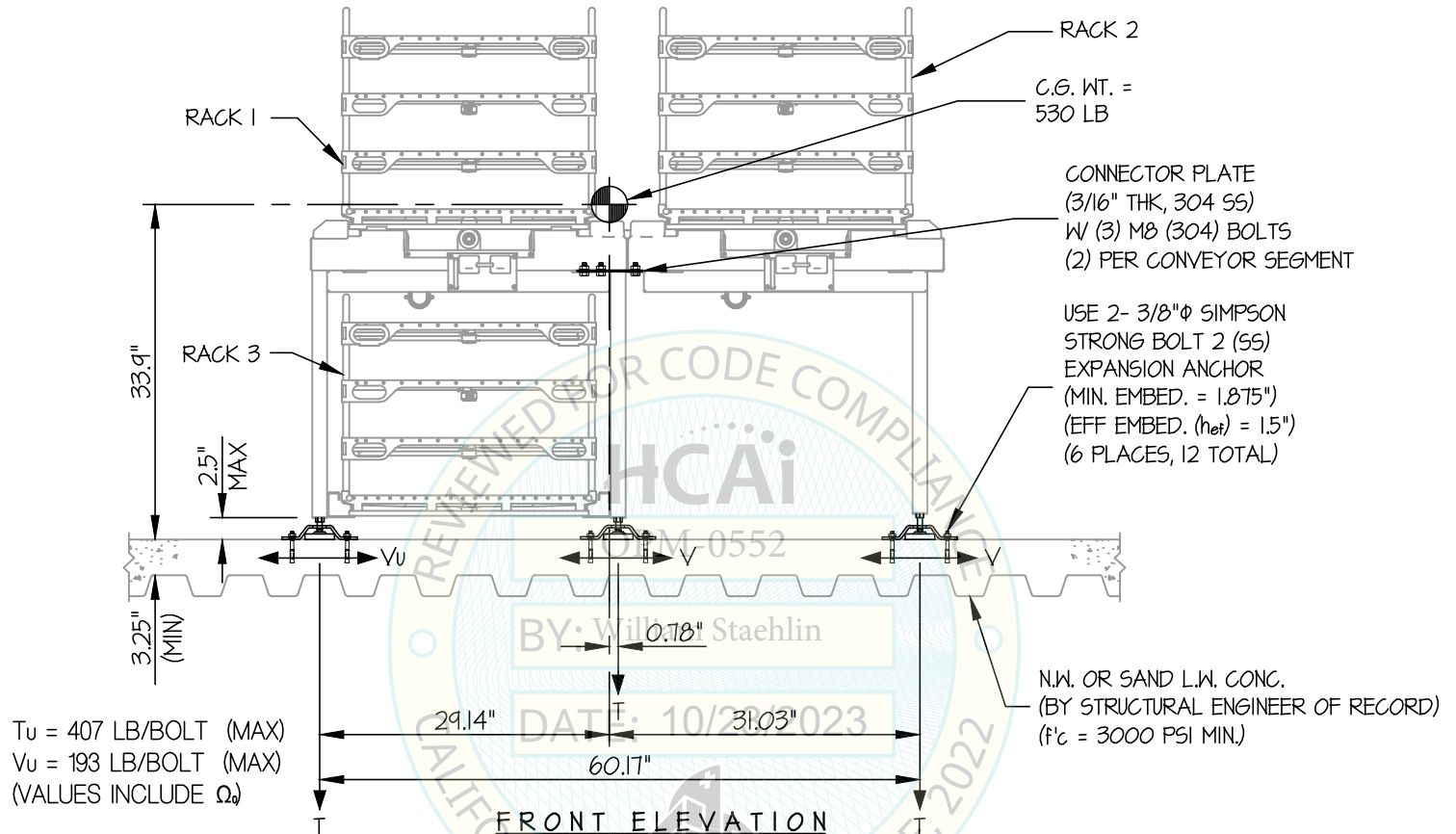

T_u = 407 LB/BOLT (MAX)
 V_u = 193 LB/BOLT (MAX)
 (VALUES INCLUDE Ω₀)

NOTES:

- FORCES ARE DETERMINED PER 2022 CALIFORNIA BUILDING CODE AND ASCE 7-16. STRENGTH DESIGN IS USED. (EXAMPLE: S_{ds} = 1.00, a_p = 1.0, l_p = 1.5, R_p = 1.5, Ω₀ = 2.0, z/h ≤ 1)

HORIZONTAL FORCE (E_h) = 1.20 W_p
 HORIZONTAL FORCE (E_{mh}) = 2.40 W_p (FOR CONCRETE ANCHORAGE)
 VERTICAL FORCE (E_v) = 0.20 W_p

- THIS PREAPPROVAL ENCOMPASSES WEIGHTS AND VERTICAL CG POSITIONS UP TO THE VALUES SHOWN.
- THIS PREAPPROVAL WAS PREPARED WITHOUT KNOWLEDGE OF ANY SITE CONDITION. COMPATIBILITY FOR USE WITH A SITE SHALL BE EVALUATED BY THE STRUCTURAL ENGINEER OF RECORD OF THE INSTALLATION (SEOR). USE REQUIRES APPROVAL BY THE SEOR.
- STRUCTURAL ENGINEER OF RECORD FOR THE INSTALLATION SHALL VERIFY ALL CONDITIONS, EVALUATE INTERACTION WITH ADJACENT EQUIPMENT AND ANCHORS, AND PROVIDE SUPPORT STRUCTURE DESIGNED TO SUPPORT WEIGHTS AND FORCES SHOWN IN COMBINATION WITH ALL OTHER LOADS THAT MAY BE PRESENT.

- SEE GENERAL NOTES: SHEETS 1 AND 2



STERIS CORPORATION

DES. J. ROBERSON

SHEET

12

JOB NO. 14-2307

DATE 10/5/23

OF 15 SHEETS

ATLAS WAV
DOUBLE STORAGE TABLE ASSY
W/ TWO LOADED (TOP) & ONE EMPTY (BOTTOM)

SEISMIC SUPPORTS & ATTACHMENTS

CONCRETE SLAB ON METAL DECK

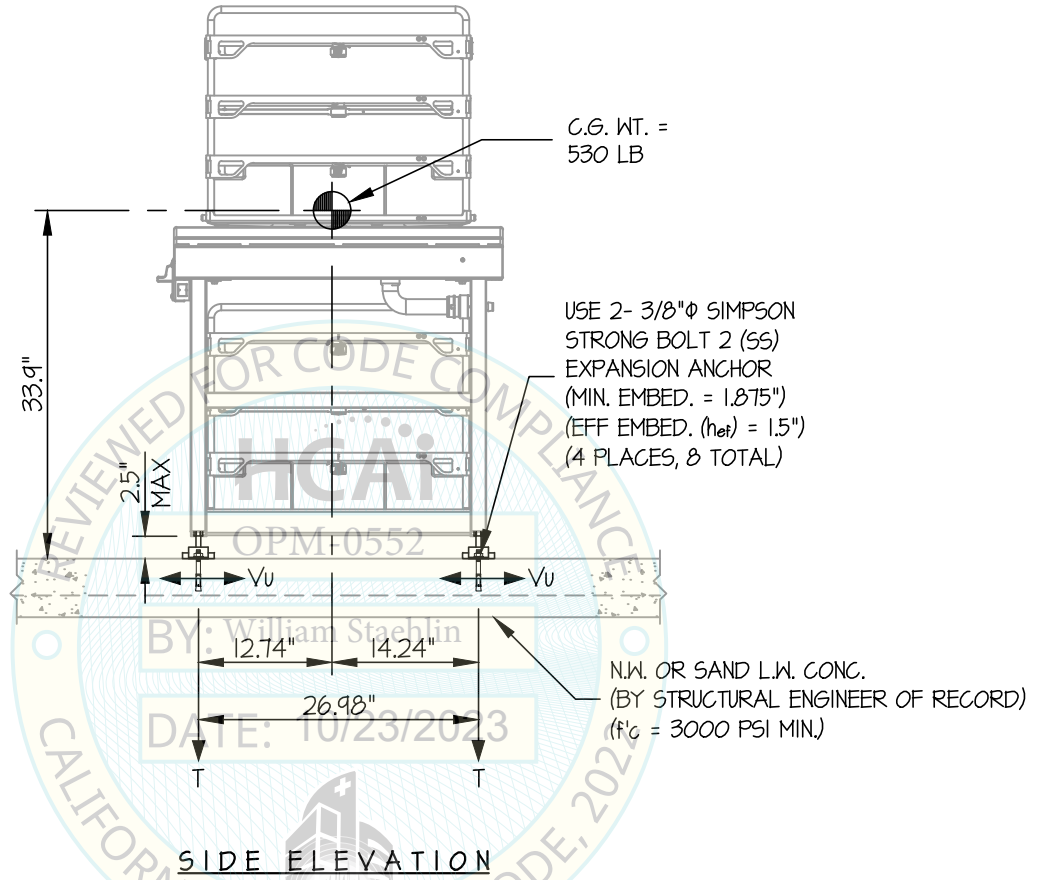

Jonathan Roberson

REGISTERED PROFESSIONAL ENGINEER
JONATHAN ROBERSON
No. 4197
EXP. 6-30-2024
10/5/23
STRUCTURAL
STATE OF CALIFORNIA

STERIS CORPORATION

DES. J. ROBERSON

SHEET

13

JOB NO. 14-2307

ATLAS WAV DOUBLE STORAGE TABLE ASSY (EMPTY)

DATE 10/5/23

OF 15 SHEETS

SEISMIC SUPPORTS & ATTACHMENTS

CONCRETE SLAB ON METAL DECK

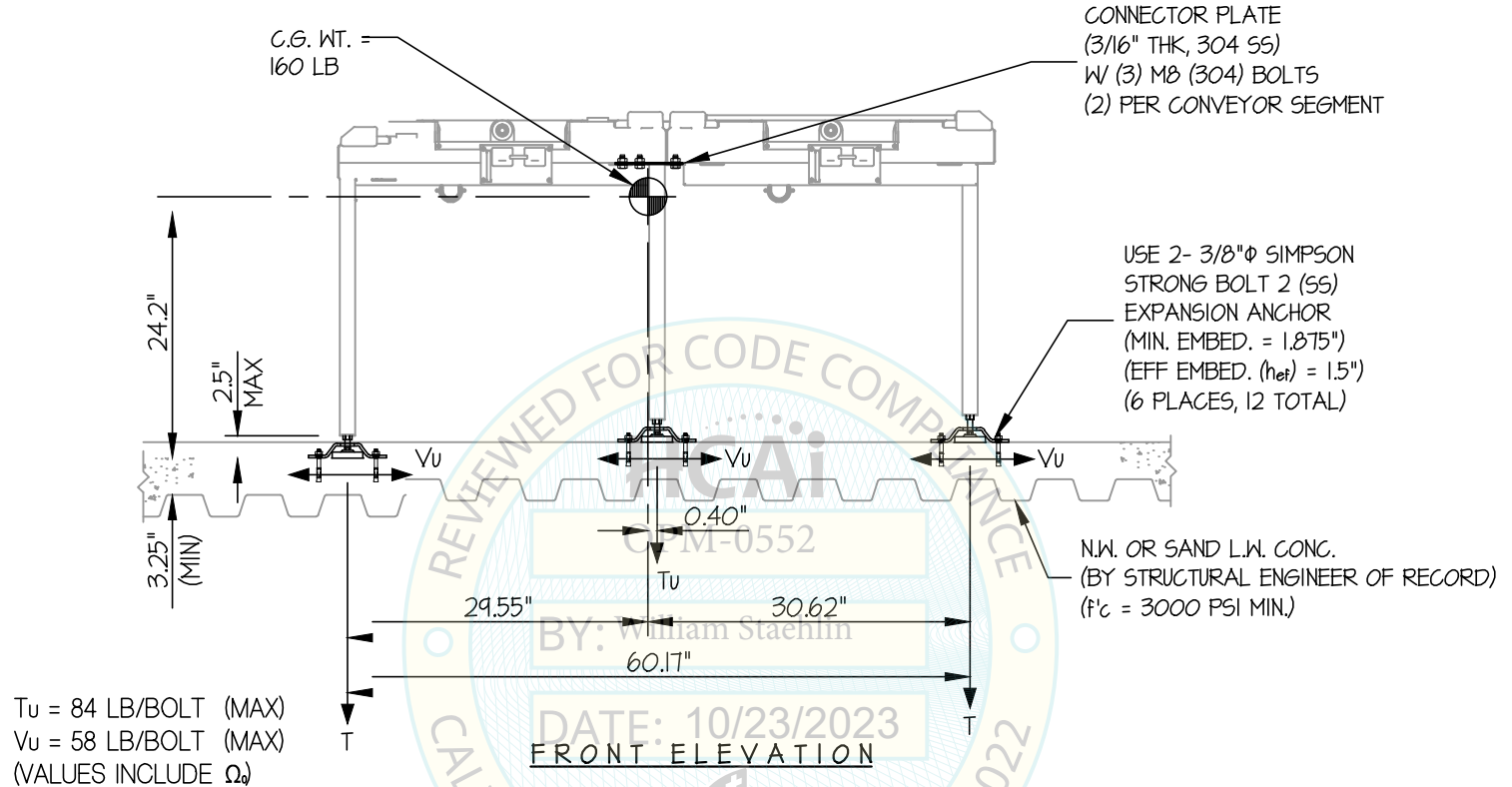

NOTES:

- FORCES ARE DETERMINED PER 2022 CALIFORNIA BUILDING CODE AND ASCE 7-16. STRENGTH DESIGN IS USED. (EXAMPLE: S_{DS} = 1.00, a_p = 1.0, I_p = 1.5, R_p = 1.5, Ω₀ = 2.0, z/h ≤ 1)

HORIZONTAL FORCE (E_h) = 1.20 W_p
 HORIZONTAL FORCE (E_{mh}) = 2.40 W_p (FOR CONCRETE ANCHORAGE)
 VERTICAL FORCE (E_v) = 0.20 W_p

- THIS PREAPPROVAL ENCOMPASSES WEIGHTS AND VERTICAL CG POSITIONS UP TO THE VALUES SHOWN.
- THIS PREAPPROVAL WAS PREPARED WITHOUT KNOWLEDGE OF ANY SITE CONDITION. COMPATIBILITY FOR USE WITH A SITE SHALL BE EVALUATED BY THE STRUCTURAL ENGINEER OF RECORD OF THE INSTALLATION (SEOR). USE REQUIRES APPROVAL BY THE SEOR.
- STRUCTURAL ENGINEER OF RECORD FOR THE INSTALLATION SHALL VERIFY ALL CONDITIONS, EVALUATE INTERACTION WITH ADJACENT EQUIPMENT AND ANCHORS, AND PROVIDE SUPPORT STRUCTURE DESIGNED TO SUPPORT WEIGHTS AND FORCES SHOWN IN COMBINATION WITH ALL OTHER LOADS THAT MAY BE PRESENT.
- SEE GENERAL NOTES: SHEETS 1 AND 2



STERIS CORPORATION

DES. J. ROBERSON

SHEET

14

JOB NO. 14-2307

DATE 10/5/23

OF 15 SHEETS

ATLAS WAW DOUBLE STORAGE TABLE ASSY (EMPTY)

SEISMIC SUPPORTS & ATTACHMENTS

CONCRETE SLAB ON METAL DECK

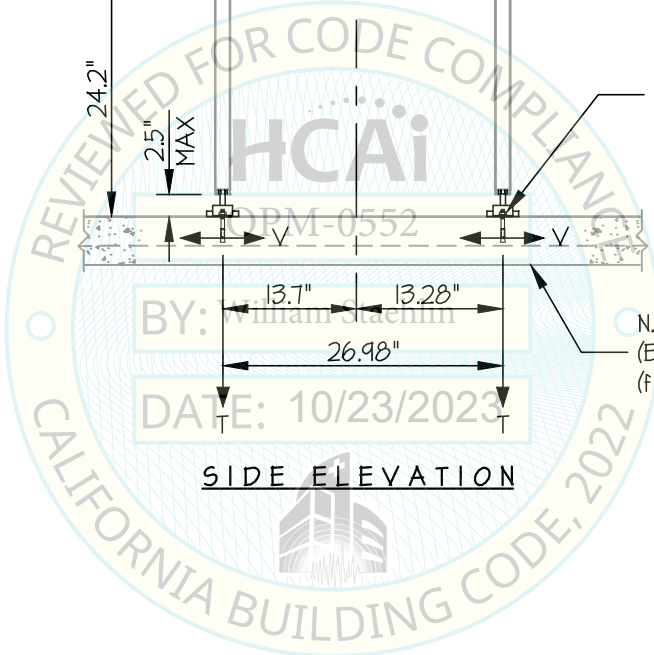
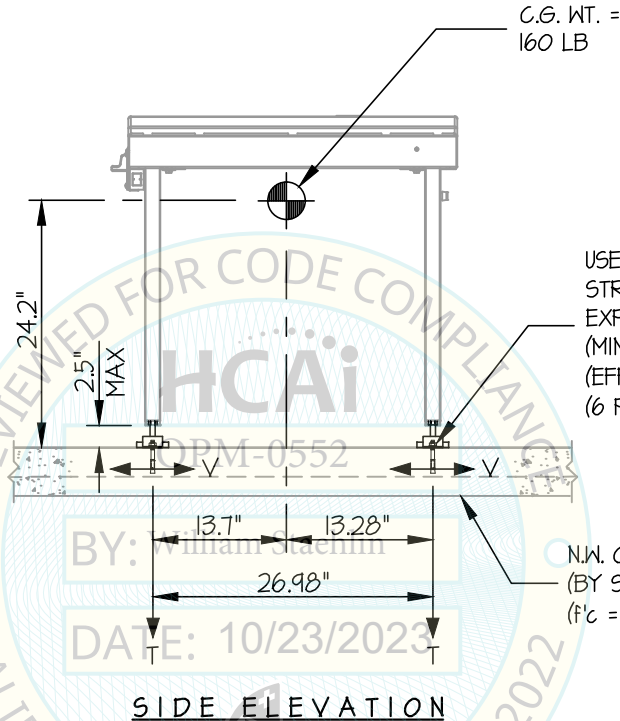

STERIS CORPORATION

DES. J. ROBERSON

SHEET
15

JOB NO. 14-2307

DATE 10/5/23

OF **15** SHEETS

ATLAS WAV SINGLE / DOUBLE STORAGE TABLE ASSY

SEISMIC SUPPORTS & ATTACHMENTS

BRACKET DETAILS

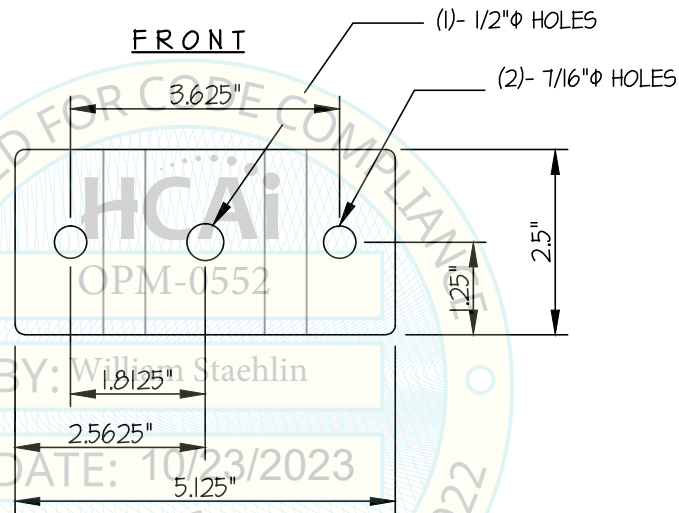
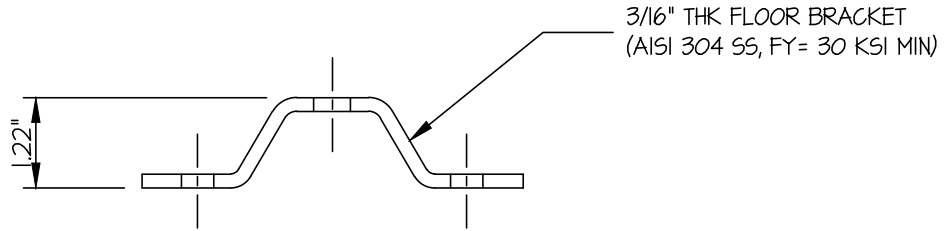

PLAN

FLOOR BRACKET DETAIL

