



**OFFICE OF STATEWIDE HEALTH PLANNING AND DEVELOPMENT  
FACILITIES DEVELOPMENT DIVISION**

**APPLICATION FOR OSHPD PREAPPROVAL OF  
MANUFACTURER'S CERTIFICATION (OPM)**

OFFICE USE ONLY

**APPLICATION #: OPM-0606**

**OSHPD Preapproval of Manufacturer's Certification (OPM)**

Type:  New  Renewal/Update

**Manufacturer Information**

Manufacturer: Instrumentation Laboratory (IL)

Manufacturer's Technical Representative: Zoran Vidovic

Mailing Address: 180 Hartwell Road, Bedford, MA 01730

Telephone: (781) 674-3374

Email: zvidovic@ilww.com

**Product Information**

Product Name: ACL TOP 750 LAS

Product Type: Other Mechanical or Electrical Components

Product Model Number: N/A

General Description: Medical Equipment used for hemostasis testing

**Applicant Information**

Applicant Company Name: EASE LLC.

Contact Person: Tiffany Tonn

Mailing Address: 1515 FAIRVIEW AVE, STE 205, MISSOULA, MT 59801

Telephone: (406) 541-3273

Email: tiffany@easeco.com

Title: Office Manager

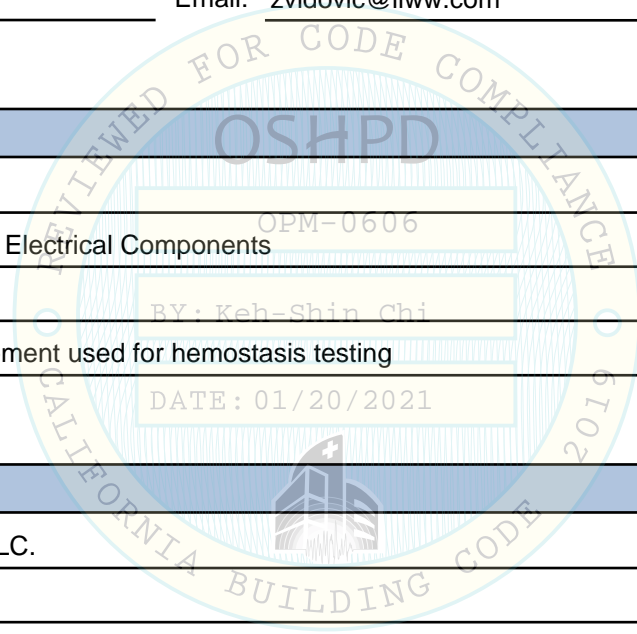

\*Access to Safe, Quality Healthcare Environments that Meet California's Diverse and Dynamic Needs\*

STATE OF CALIFORNIA – HEALTH AND HUMAN SERVICES AGENCY





**OFFICE OF STATEWIDE HEALTH PLANNING AND DEVELOPMENT  
FACILITIES DEVELOPMENT DIVISION**

**Registered Design Professional Preparing Engineering Recommendations**

Company Name: EASE  
Name: Jonathan Roberson California License Number: S4197  
Mailing Address: 5877 Pine Ave., Suite 210, Chino Hills, CA 91709  
Telephone: (951) 295-1892 Email: jon@EASECo.com

**OSHPD Special Seismic Certification Preapproval (OSP)**

Special Seismic Certification is preapproved under OSP OSP Number: \_\_\_\_\_

**Certification Method**

Testing in accordance with:  ICC-ES AC156  FM 1950-16  
 Other(s) (Please Specify): \_\_\_\_\_

\*Use of criteria other than those adopted by the California Building Standards Code, 2019 (CBSC 2019) for component supports and attachments are not permitted. For distribution system, interior partition wall, and suspended ceiling seismic bracings, test criteria other than those adopted in the CBSC 2019 may be used when approved by OSHPD prior to testing.

- Analysis
- Experience Data
- Combination of Testing, Analysis, and/or Experience Data (Please Specify): \_\_\_\_\_

**OSHPD Approval**

Date: 1/20/2021  
Name: Keh-Shin Chi Title: Senior Structural Engineer  
Condition of Approval (if applicable): \_\_\_\_\_



**EQUIPMENT ANCHORAGE  
& SEISMIC ENGINEERING**

5877 Pine Ave, Ste. 210  
Chino Hills, CA. 91709  
Phn: (909) 606-7622

Office of Statewide Health Planning and Development  
**PREAPPROVAL OF MANUFACTURER'S CERTIFICATION**  
**OPM-0606**

**THIS PREAPPROVAL CONFORMS TO THE 2019 CALIFORNIA BUILDING CODE**

MANUFACTURER: **INSTRUMENTATION LABORATORY**  
EQUIPMENT NAME: **ACL TOP 750 LAS**

Sheet: 1 of 9  
Date: 1/18/21

**GENERAL NOTES**

1. THIS OSHPD PREAPPROVAL OF MANUFACTURER'S CERTIFICATION (OPM) IS BASED ON THE 2019 CBC. THE DEMANDS (DESIGN FORCES) FOR USE WITH THIS OPM SHALL BE BASED ON THE 2019 CBC
2. THIS DOCUMENT MAY ONLY BE USED WITH THE EXPRESS WRITTEN CONSENT OF THE MANUFACTURER LISTED ABOVE FOR THE SPECIFIC PROJECT SITE AND INSTALLATION LOCATION. THIS DOCUMENT IS INVALID WITHOUT SUCH CONSENT.
3. THIS PREAPPROVAL CONFORMS TO THE 2019 CALIFORNIA BUILDING CODE WHERE  $S_{ds}$  IS NOT GREATER THAN 1.40, 1.80 & 2.30. SEE DETAIL FOR APPLICABILITY
4. FORCES PER ASCE 7-16 SECTION 13.3.1, EQUATIONS 13.3-1, 13.3-2 & 13.3-3,  
WHERE  $S_{ds} = 1.40$ ,  $a_p = 1.0$ ,  $I_p = 1.5$ ,  $R_p = 1.5$ ,  $z/h = 0$  AT CONCRETE SLAB. SEE FOLLOWING SHEETS FOR  $\Omega_o$   
WHERE  $S_{ds} = 2.30$ ,  $a_p = 1.0$ ,  $I_p = 1.5$ ,  $R_p = 1.5$ ,  $z/h = 0$  AT CONCRETE SLAB. SEE FOLLOWING SHEETS FOR  $\Omega_o$   
WHERE  $S_{ds} = 1.80$ ,  $a_p = 1.0$ ,  $I_p = 1.5$ ,  $R_p = 1.5$ ,  $z/h < 1$  AT CONCRETE SLAB ON METAL DECK.  
SEE FOLLOWING SHEETS FOR  $\Omega_o$
5. THIS PREAPPROVAL COVERS ONLY THE SUPPORTS AND ATTACHMENTS OF THE EQUIPMENT TO THE STRUCTURE.
6. ALL DESIGN FORCES SHOWN ON THE DRAWINGS ARE FACTORED LOADS THAT SHALL BE USED FOR STRENGTH DESIGN.
7. CONCRETE SLAB ON METAL DECK DETAIL VALID FOR DEMANDS SHOWN AT ANY ELEVATION IN THE BUILDING. (i.e.  $z/h \leq 1$ )
8. CONCRETE SLAB DETAIL VALID FOR DEMANDS SHOWN AT OR BELOW GRADE. (i.e.  $z/h = 0$ )
9. **RESPONSIBILITIES OF THE STRUCTURAL ENGINEER OF RECORD OF THE BUILDING**
  - A. PROVIDE SUPPORTING STRUCTURE TO SUPPORT WEIGHTS AND FORCES SHOWN IN ADDITION TO ALL OTHER LOADS.
  - B. VERIFY THAT THE INSTALLATION IS IN CONFORMANCE WITH THE 2019 CBC AND WITH THE DETAILS, MATERIAL AND GAGE OF THE UNIT WHERE ATTACHMENTS ARE MADE AGREE WITH THE INFORMATION SHOWN ON THE PREAPPROVAL DOCUMENTS.
  - C. VERIFY THAT PROJECT SPECIFIC VALUES OF  $S_{ds}$  &  $z/h$  RESULT IN SEISMIC FORCES ( $E_h$ ,  $E_v$ ) THAT DO NOT EXCEED THE VALUES ON THE DETAILS.
  - D. VERIFY THAT THE CONCRETE SLAB TO WHICH THE EQUIPMENT IS ANCHORED MEETS THE REQUIREMENTS OF THE APPLICABLE ICC ESR REPORT. AND THIS OPM.
  - E. VERIFY THAT THE ANCHORS ARE AN ADEQUATE DISTANCE FROM ANY SLAB EDGES OR OPENINGS (SEE TYPICAL DETAIL ON SHEET 2).
  - F. VERIFY THAT ALL NEW OR EXISTING ANCHORS ARE AN ADEQUATE DISTANCE FROM THE UNIT ATTACHMENTS AND CHECK FOR INTERACTION WHERE OTHER ANCHORS ARE WITHIN 18" OR  $6h_{ef}$  FROM THIS UNIT'S ANCHORS.

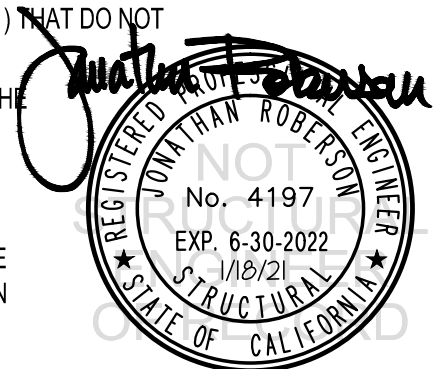

### INSTRUMENTATION LABORATORY

DES. **J. ROBERSON**

SHEET

**2**

JOB NO. **11-1926**

### ACL TOP 750 LAS

DATE **1/18/21**

OF **9** SHEETS

#### 10. EXPANSION ANCHORS:

- A. ATTACHMENT IS TO BE MADE WITH THE ANCHORS LISTED BELOW AND INSTALLED AS DESCRIBED IN THE CORRESPONDING ICC REPORT.

| Anchor Diameter | Concrete Type     | Min. f'c (psi) | Anchor Type        | ICC Report No. | Min. Embed. | Min. Spacing | Min. Edge Dist. | Min. Conc. Thickness | Torque Test | Direct Tension Test |
|-----------------|-------------------|----------------|--------------------|----------------|-------------|--------------|-----------------|----------------------|-------------|---------------------|
| 3/8"            | Sand Light Weight | 3000           | Hilti Kwik Bolt TZ | ESR-1917       | 2"          | 6.75"        | 12"             | See Detail "A"       | 25 FT-LB    | N/A                 |
| 1/2"            | Normal Weight     | 3000           | Hilti Kwik Bolt TZ | ESR-1917       | 2"          | 3"           | 9"              | 4"                   | 40 FT-LB    | 1204 lb             |
| 1/2"            | Normal Weight     | 3000           | Hilti Kwik Bolt TZ | ESR-1917       | 3.25"       | 3"           | 24"             | 6"                   | 40 FT-LB    | 2174 lb             |

- B. THIS PREAPPROVAL ALLOWS FOR UP TO A MAXIMUM OF 2 ADJACENT CONCRETE SLAB EDGES, 9" & 24" AWAY MINIMUM (i.e. - CORNER).

SEE ADJACENT DETAIL FOR ADDITIONAL MINIMUM ALLOWABLE CONCRETE EDGE DISTANCES.

- C. TESTING AND SPECIAL INSPECTION OF EXPANSION ANCHORS SHALL BE PERFORMED BY AN APPROVED INDEPENDENT AGENCY EMPLOYED BY THE FACILITY OWNER PER CBC 1704A & 1910A.5 AND CAC 7-149. ALL REPORTS SHALL BE SENT TO THE INSPECTOR OF RECORD, OWNER AND THE ARCHITECT OR ENGINEER IN RESPONSIBLE CHARGE.

- (i) AFTER AT LEAST 24 HOURS HAVE ELAPSED SINCE INSTALLATION, DIRECT PULL TENSION TEST OR TORQUE TEST AT LEAST 50% OF THE ANCHORS.

- (ii) ACCEPTANCE CRITERIA:

- DIRECT TENSION TEST: THE ANCHOR SHOULD HAVE NO OBSERVABLE MOVEMENT AT THE TEST LOAD. A PRACTICAL WAY TO DETERMINE OBSERVABLE MOVEMENT IS THAT THE WASHER BECOMES LOOSE.
- TORQUE TEST: THE APPLICABLE TORQUE MUST BE ACHIEVED WITHIN THE FOLLOWING LIMITS: WEDGE TYPE : 1/2 TURN OF THE NUT

- (iii) IF ANY ANCHOR FAILS, TEST ALL ANCHORS.

- D. AVOID DAMAGING EXISTING STEEL REINFORCING IN CONCRETE SLAB WHEN INSTALLING CONCRETE EXPANSION ANCHORS.

- E. PROVIDE FOR FULL THREAD ENGAGEMENT OF NUT & WASHER.

#### 11. BOLTS THROUGH CONCRETE ON METAL DECK

- A. BOLTS SHALL BE TORQUED BY 3/4 TURN OF THE NUTS AFTER THE SNUG TIGHT (THE SNUG-TIGHT CONDITION IS DEFINED AS THE TIGHTNESS REQUIRED TO BRING THE CONNECTED PLIES INTO FIRM CONTACT) CONDITION IS ACHIEVED, UNLESS OTHERWISE NOTED.
- B. THROUGH BOLT HOLES SHALL BE 1/16" LARGER THAN BOLT SIZE (HOLE SIZE = BOLT SIZE + 1/16) FOR CONCRETE.
- C. THROUGH-BOLTS IN CONCRETE SHALL RECEIVE SPECIAL INSPECTION AND TESTING (THROUGH BOLTS WITH STEEL TO STEEL CONNECTION IN TENSION DO NOT REQUIRE TENSION TESTING) IN ACCORDANCE WITH REQUIREMENTS FOR POST-INSTALLED ANCHORS.

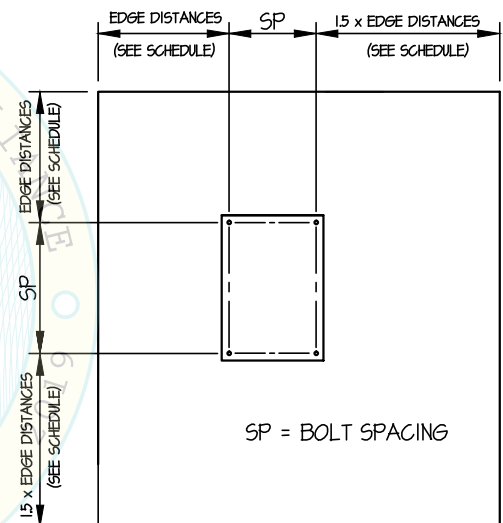

TYPICAL CONCRETE EDGE DETAIL

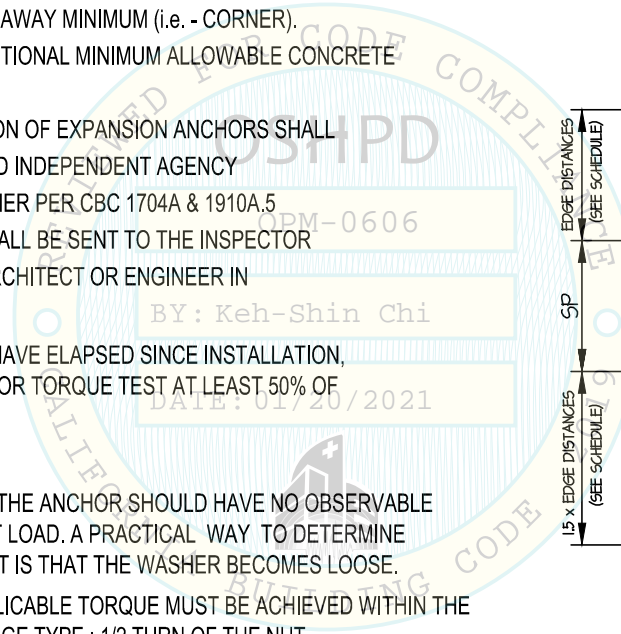

### INSTRUMENTATION LABORATORY

DES. **J. ROBERSON**

SHEET

**3**

JOB NO. **11-1926**

### ACL TOP 750 LAS

DATE **1/18/21**

OF **9** SHEETS

SEISMIC SUPPORTS & ATTACHMENTS

CONCRETE SLAB

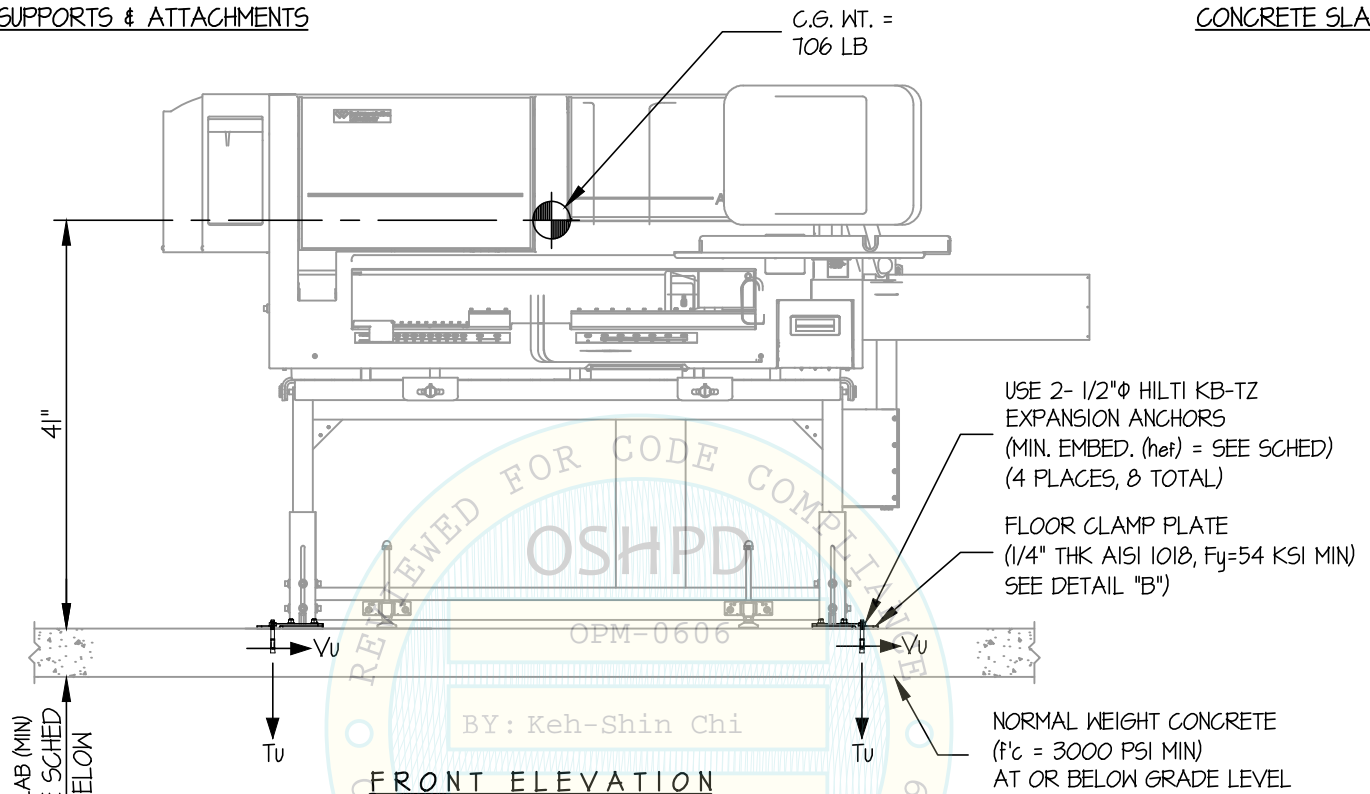

FRONT ELEVATION

ANCHORS

| MAX Sds    | TYPE        | DIAM | EFF EMBED | QTY | T <sub>SLAB</sub> | *T <sub>u</sub> (lb) | *V <sub>u</sub> (lb) |
|------------|-------------|------|-----------|-----|-------------------|----------------------|----------------------|
| <b>140</b> | HILTI KB-TZ | 1/2" | 2"        | 8   | 4"                | 854                  | 272                  |
| <b>230</b> | HILTI KB-TZ | 1/2" | 3.25"     | 8   | 6"                | 1573                 | 447                  |

\* VALUES INCLUDE  $\Omega_o$

**NOTES:**

- FORCES ARE DETERMINED PER 2019 CALIFORNIA BUILDING CODE AND ASCE 7-16**  
STRENGTH DESIGN IS USED. ( $\alpha_p = 1.0, l_p = 1.5, R_p = 1.5, \Omega_o = 2.0, z/h = 0$ )
- CENTER OF GRAVITY (C.G.) AND WEIGHT ARE THE GOVERNING PARAMETERS FOR DESIGN. THIS PREAPPROVAL ENCOMPASSES ALL WEIGHTS UP TO THE MAXIMUM WEIGHT SHOWN.
- STRUCTURAL ENGINEER OF RECORD FOR THE BUILDING SHALL PROVIDE SUPPORT STRUCTURE DESIGNED TO SUPPORT WEIGHTS AND FORCES SHOWN IN COMBINATION WITH ALL OTHER LOADS THAT MAY BE PRESENT.
- SEE GENERAL NOTES: SHEETS 1 AND 2

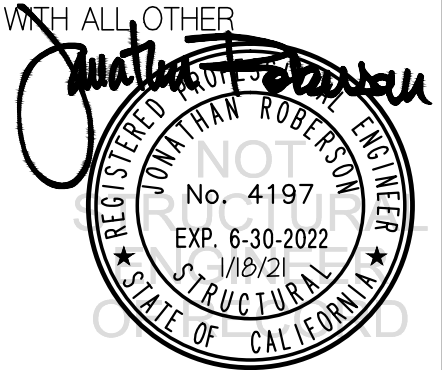

### INSTRUMENTATION LABORATORY

DES. J. ROBERSON

SHEET

4

JOB NO. 11-1926

### ACL TOP 750 LAS

DATE 1/18/21

OF 9 SHEETS

SEISMIC SUPPORTS & ATTACHMENTS

MAX  $S_{Ds} \leq 1.40$

CONCRETE SLAB

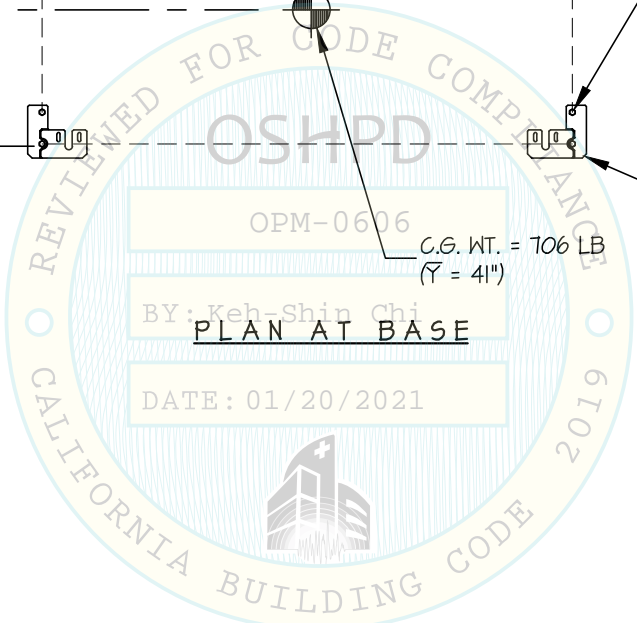
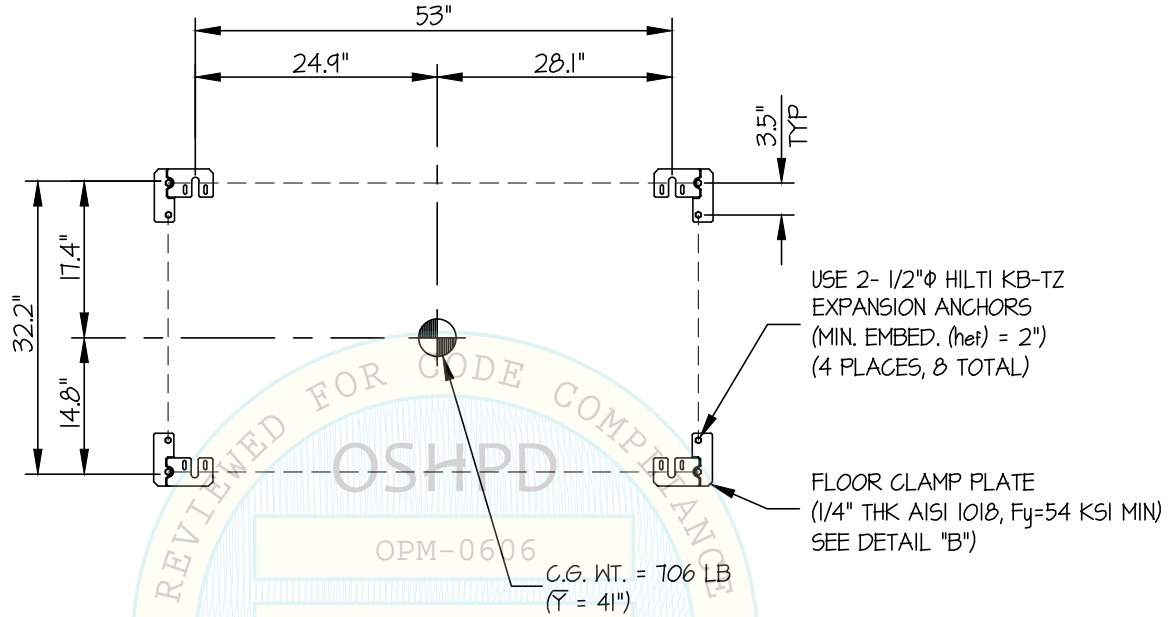

### INSTRUMENTATION LABORATORY

DES. J. ROBERSON

SHEET

5

JOB NO. 11-1926

### ACL TOP 750 LAS

DATE 1/18/21

OF 9 SHEETS

SEISMIC SUPPORTS & ATTACHMENTS

1.40 < MAX Sps ≤ 2.30

CONCRETE SLAB

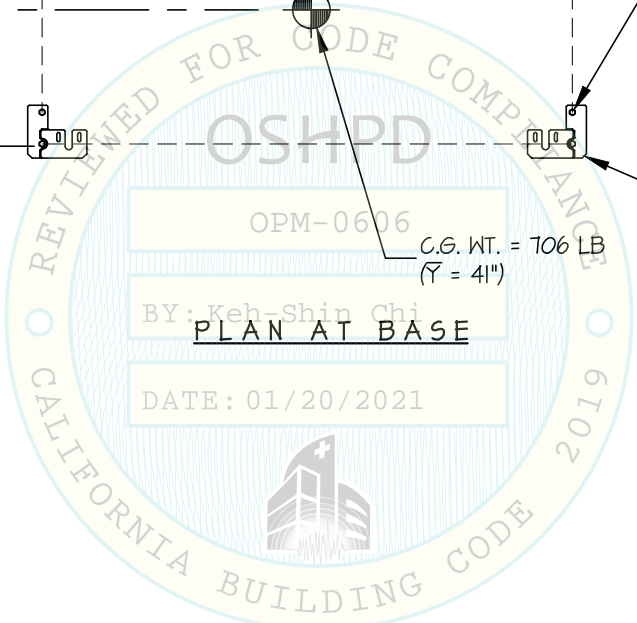
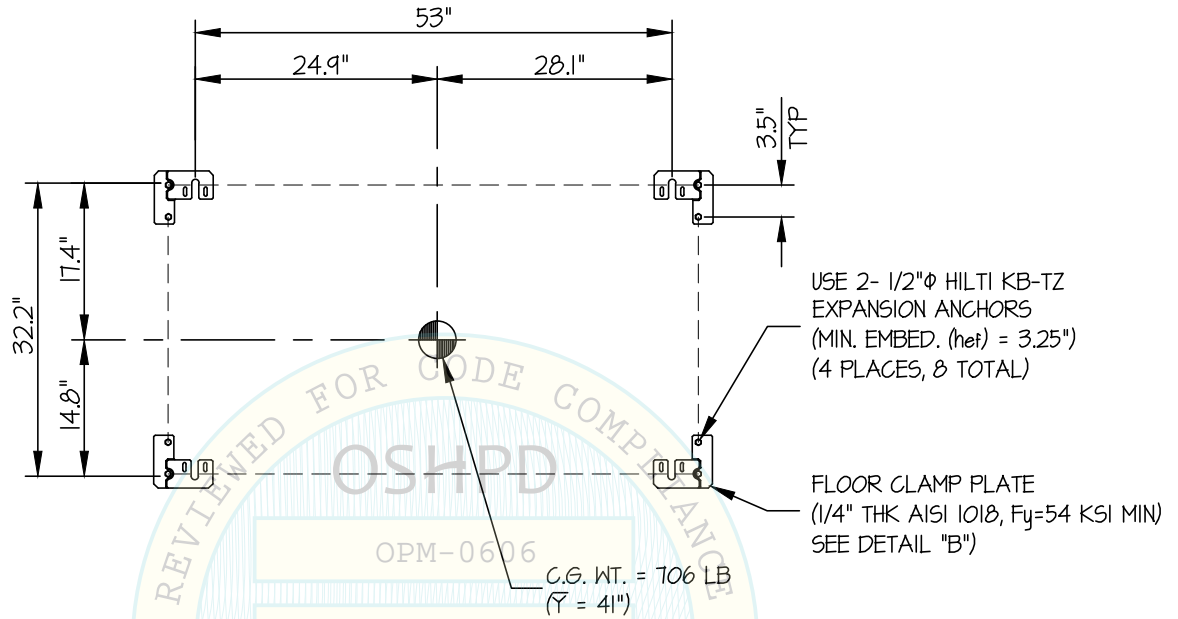

### INSTRUMENTATION LABORATORY

DES. J. ROBERSON

SHEET

6

JOB NO. 11-1926

### ACL TOP 750 LAS

DATE 1/18/21

OF 9 SHEETS

SEISMIC SUPPORTS & ATTACHMENTS

CONCRETE SLAB ON METAL DECK

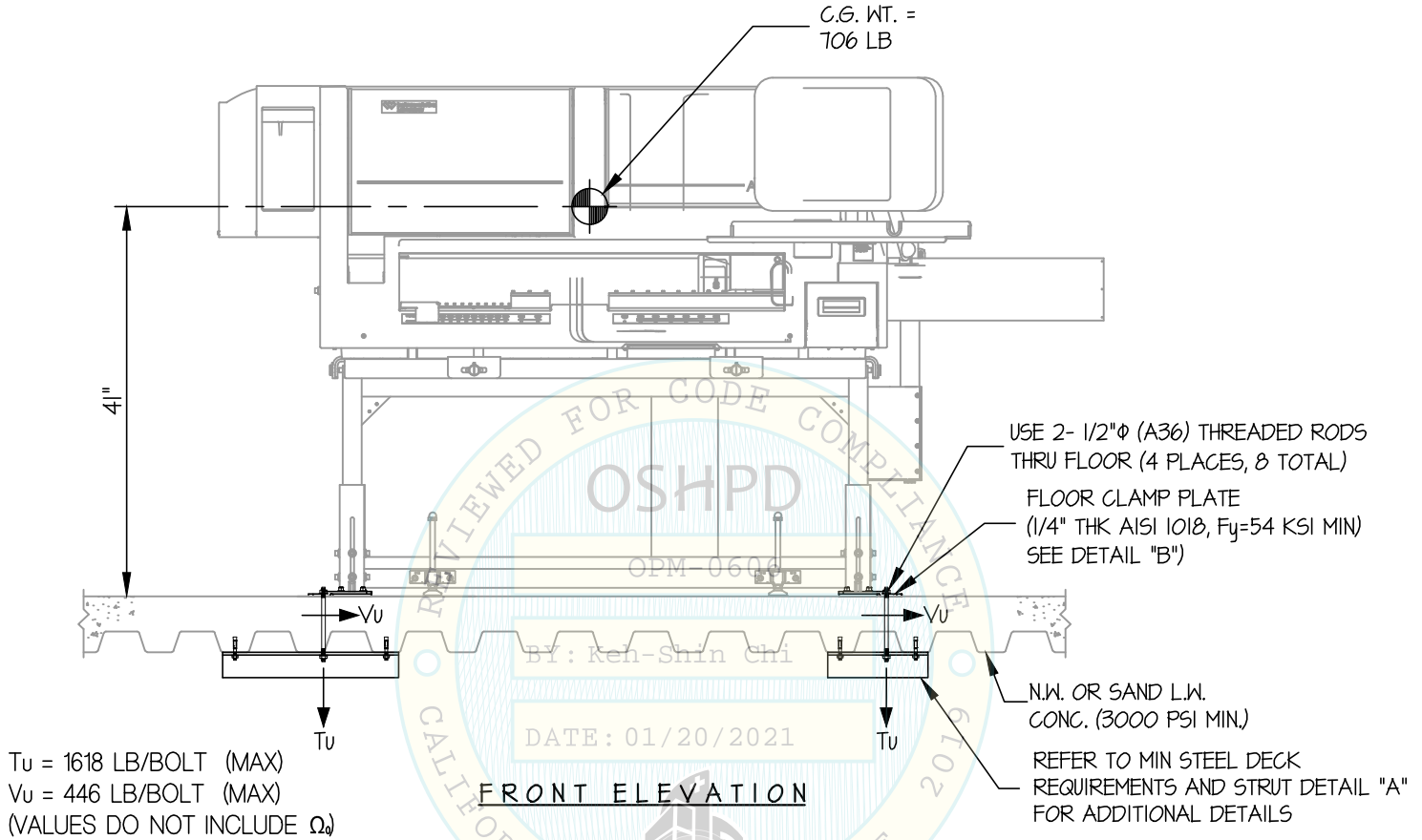

**NOTES:**

- FORCES ARE DETERMINED PER 2019 CALIFORNIA BUILDING CODE AND ASCE 7-16.

STRENGTH DESIGN IS USED. ( $S_{ds} = 1.80$ ,  $a_p = 1.0$ ,  $l_p = 1.5$ ,  $R_p = 1.5$ ,  $\Omega_o = 2.0$ ,  $z/h \leq 1$ )

HORIZONTAL FORCE ( $E_h$ ) =  $2.16 W_p$

HORIZONTAL FORCE ( $E_{mh}$ ) =  $4.32 W_p$  (FOR CONCRETE ANCHORAGE)

VERTICAL FORCE ( $E_v$ ) =  $0.36 W_p$

- CENTER OF GRAVITY (C.G.) AND WEIGHT ARE THE GOVERNING PARAMETERS FOR DESIGN. THIS PREAPPROVAL ENCOMPASSES ALL WEIGHTS UP TO THE MAXIMUM WEIGHT SHOWN.
- STRUCTURAL ENGINEER OF RECORD FOR THE BUILDING SHALL PROVIDE SUPPORT STRUCTURE DESIGNED TO SUPPORT WEIGHTS AND FORCES SHOWN IN COMBINATION WITH ALL OTHER LOADS THAT MAY BE PRESENT.
- SEE GENERAL NOTES: SHEETS 1 AND 2





### INSTRUMENTATION LABORATORY

DES. J. ROBERSON

SHEET

7

JOB NO. 11-1926

### ACL TOP 750 LAS

DATE 1/18/21

OF 9 SHEETS

SEISMIC SUPPORTS & ATTACHMENTS

CONCRETE SLAB ON METAL DECK

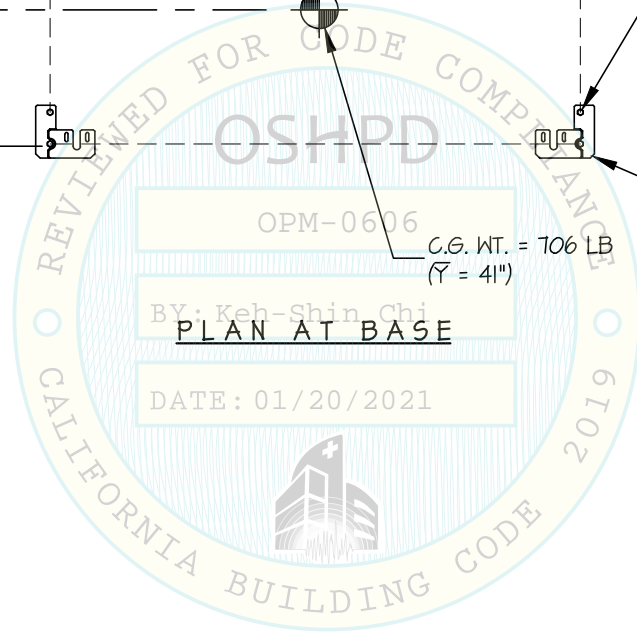
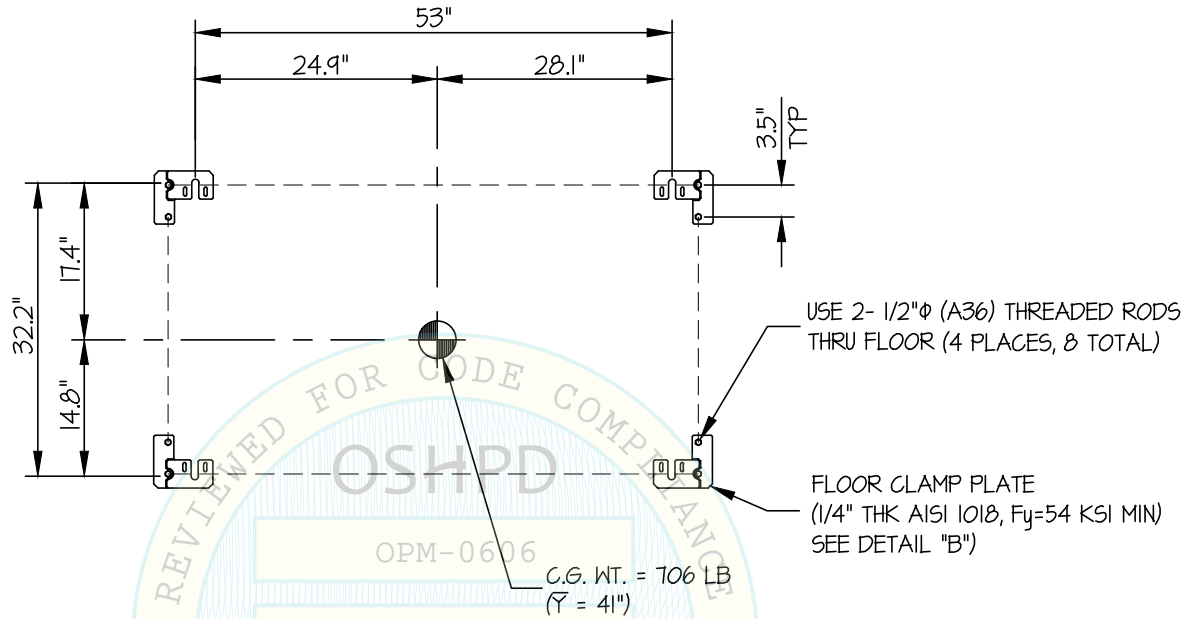

## INSTRUMENTATION LABORATORY

DES. **J. ROBERSON**

SHEET

**8**

JOB NO. **11-1926**

## ACL TOP 750 LAS

DATE **1/18/21**

OF **9** SHEETS

SEISMIC SUPPORTS & ATTACHMENTS

CONCRETE DETAIL

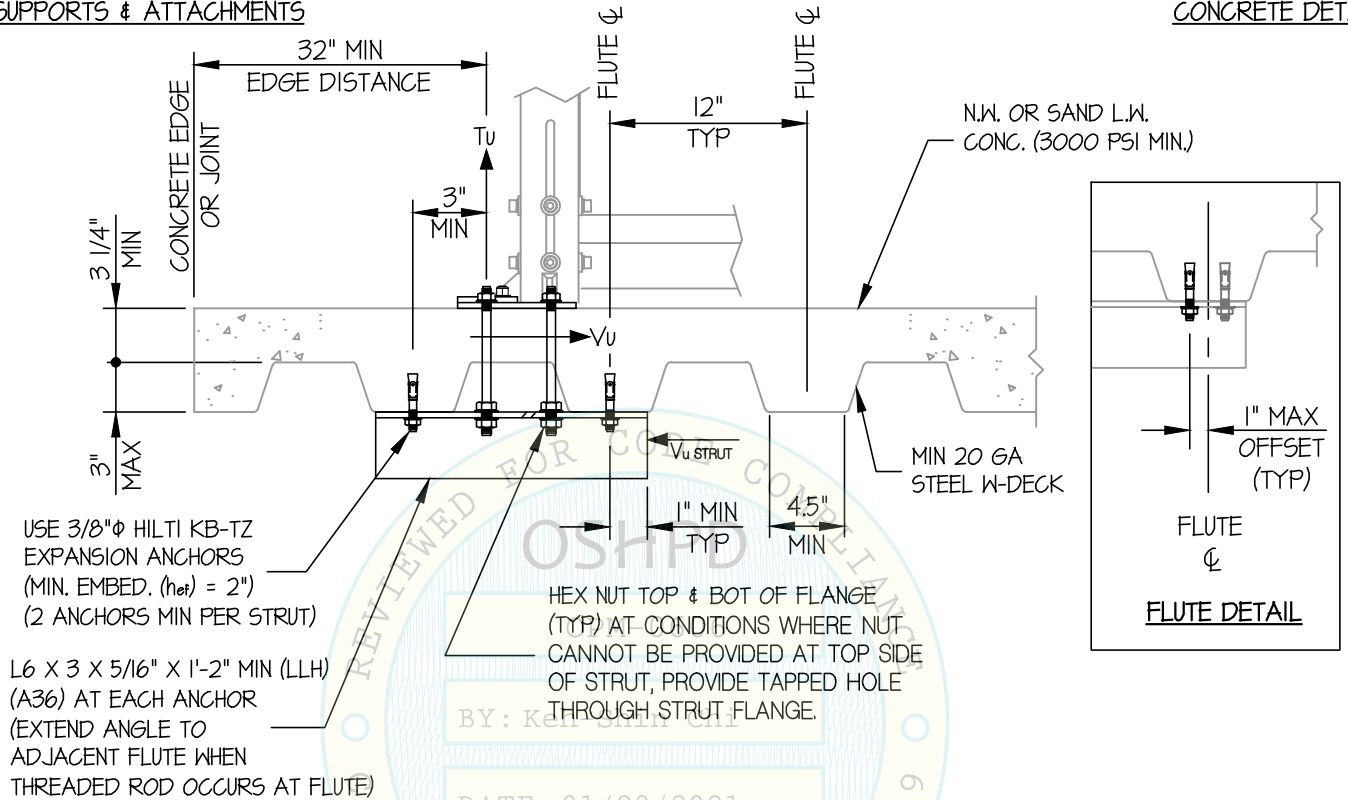

**MIN STEEL DECK REQUIREMENTS AND STRUT DETAIL (A)**

*Jonathan Roberson*

REGISTERED PROFESSIONAL ENGINEER  
No. 4197  
EXP. 6-30-2022  
1/18/21  
STRUCTURAL  
STATE OF CALIFORNIA

## INSTRUMENTATION LABORATORY

DES. **J. ROBERSON**

SHEET

**9**

JOB NO. **11-1926**

## ACL TOP 750 LAS

DATE **1/18/21**

OF **9** SHEETS

SEISMIC SUPPORTS & ATTACHMENTS

BRACKET DETAIL

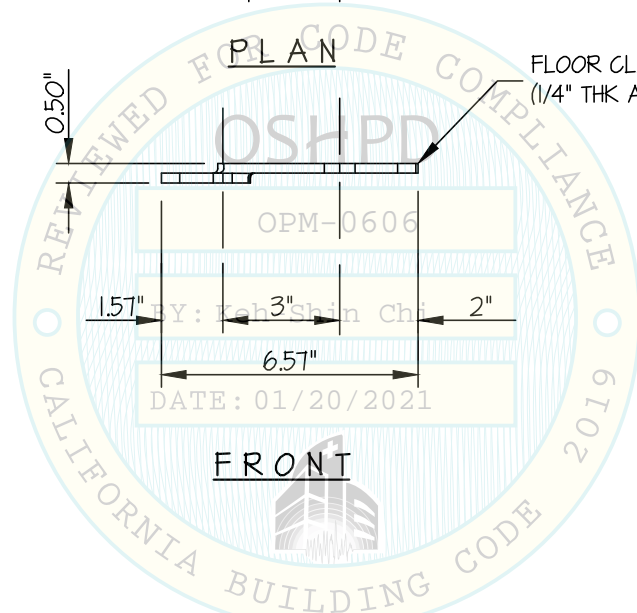
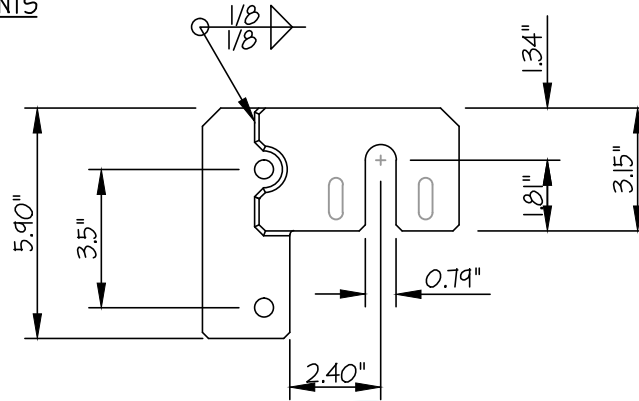

FLOOR CLAMP PLATE  
(1/4" THK AISI 1018, Fy=54 KSI MIN)

FRONT

BRACKET DETAIL (B)

