



**OFFICE OF STATEWIDE HEALTH PLANNING AND DEVELOPMENT  
FACILITIES DEVELOPMENT DIVISION**

**APPLICATION FOR OSHPD PREAPPROVAL OF  
MANUFACTURER'S CERTIFICATION (OPM)**

OFFICE USE ONLY

**APPLICATION #: OPM-0611**

**OSHPD Preapproval of Manufacturer's Certification (OPM)**

Type:  New  Renewal/Update

**Manufacturer Information**

Manufacturer: AGFA Healthcare Corporation

Manufacturer's Technical Representative: Brendan Conley

Mailing Address: 10 South Academy Street, Greenville, SC 29601

Telephone: (214) 548-7214 Email: brendan.conley@agfa.com

**Product Information**

Product Name: DR 800 RF Table

Product Type: Other Mechanical & Electrical Components

Product Model Number: N/A

General Description: Radiology Table for the DR 800 System

**Applicant Information**

Applicant Company Name: EASE LLC.

Contact Person: Tiffany Tonn

Mailing Address: 1515 FAIRVIEW AVE, STE 205, MISSOULA, MT 59801

Telephone: (406) 541-3273 Email: tiffany@easeco.com

Title: Office Manager

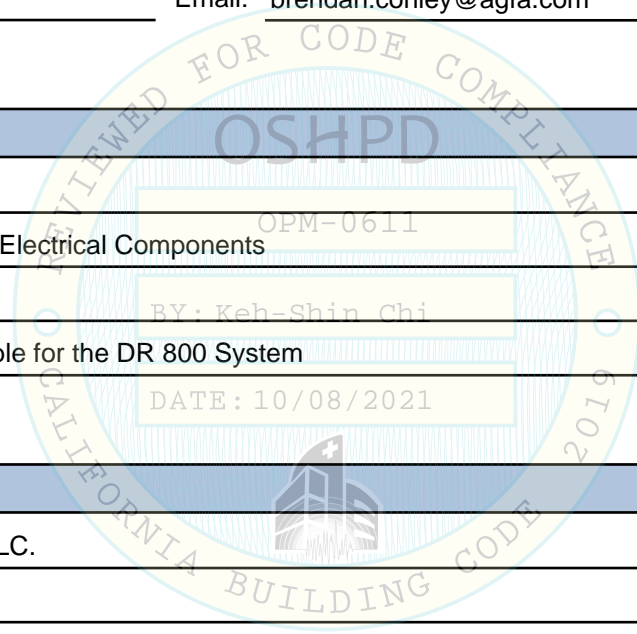

*"Access to Safe, Quality Healthcare Environments that Meet California's Diverse and Dynamic Needs"*

STATE OF CALIFORNIA – HEALTH AND HUMAN SERVICES AGENCY





**OFFICE OF STATEWIDE HEALTH PLANNING AND DEVELOPMENT  
FACILITIES DEVELOPMENT DIVISION**

**Registered Design Professional Preparing Engineering Recommendations**

Company Name: EASE

Name: Jonathan Roberson

California License Number: S4197

Mailing Address: 5877 Pine Ave., Suite 210, Chino Hills, CA 91709

Telephone: (951) 295-1892

Email: jon@EASECo.com

**OSHPD Special Seismic Certification Preapproval (OSP)**

Special Seismic Certification is preapproved under OSP

OSP Number: 0526

**Certification Method**

Testing in accordance with:  ICC-ES AC156  FM 1950-16

Other(s) (Please Specify): \_\_\_\_\_

\*Use of criteria other than those adopted by the California Building Standards Code, 2019 (CBSC 2019) for component supports and attachments are not permitted. For distribution system, interior partition wall, and suspended ceiling seismic bracings, test criteria other than those adopted in the CBSC 2019 may be used when approved by OSHPD prior to testing.

Analysis

Experience Data

Combination of Testing, Analysis, and/or Experience Data (Please Specify): \_\_\_\_\_

**OSHPD Approval**

Date: 10/8/2021

Name: Keh-Shin Chi

Title: Senior Structural Engineer

Condition of Approval (if applicable): \_\_\_\_\_

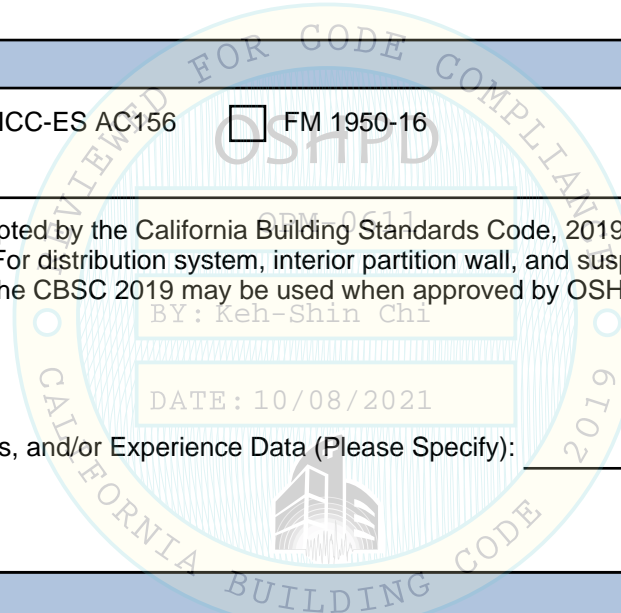



**EQUIPMENT ANCHORAGE  
& SEISMIC ENGINEERING**

5877 Pine Ave, Ste. 210  
Chino Hills, CA. 91709  
Phn: (909) 606-7622

Office of Statewide Health Planning and Development  
**PREAPPROVAL OF MANUFACTURER'S CERTIFICATION**  
**OPM-0611**

**THIS PREAPPROVAL CONFORMS TO THE 2019 CALIFORNIA BUILDING CODE**

MANUFACTURER: **AGFA HEALTHCARE CORP**  
EQUIPMENT NAME: **DR 800 RF TABLE**

Sheet: 1 of 7  
Date: 7/23/21

**GENERAL NOTES**

1. THIS OSHPD PREAPPROVAL OF MANUFACTURER'S CERTIFICATION (OPM) IS BASED ON THE 2019 CBC. THE DEMANDS (DESIGN FORCES) FOR USE WITH THIS OPM SHALL BE BASED ON THE 2019 CBC
2. THIS DOCUMENT MAY ONLY BE USED WITH THE EXPRESS WRITTEN CONSENT OF THE MANUFACTURER LISTED ABOVE FOR THE SPECIFIC PROJECT SITE AND INSTALLATION LOCATION. THIS DOCUMENT IS INVALID WITHOUT SUCH CONSENT.
3. THIS PREAPPROVAL CONFORMS TO THE 2019 CALIFORNIA BUILDING CODE WHERE  $S_{ds}$  IS NOT GREATER THAN 1.10 & 2.00. SEE DETAIL FOR APPLICABILITY
4. FORCES PER ASCE 7-16 SECTION 13.3.1, EQUATIONS 13.3-1, 13.3-2 & 13.3-3,  
WHERE  $S_{ds} = 1.10$ ,  $a_p = 1.0$ ,  $I_p = 1.5$ ,  $R_p = 1.5$ ,  $z/h = 0$  AT CONCRETE SLAB. SEE FOLLOWING SHEETS FOR  $\Omega_o$   
WHERE  $S_{ds} = 2.00$ ,  $a_p = 1.0$ ,  $I_p = 1.5$ ,  $R_p = 1.5$ ,  $z/h \leq 1$  AT CONCRETE SLAB ON METAL DECK. SEE FOLLOWING SHEETS FOR  $\Omega_o$
5. THIS PREAPPROVAL COVERS ONLY THE SUPPORTS AND ATTACHMENTS OF THE EQUIPMENT TO THE STRUCTURE.
6. ALL DESIGN FORCES SHOWN ON THE DRAWINGS ARE FACTORED LOADS THAT SHALL BE USED FOR STRENGTH DESIGN.
7. CONCRETE SLAB ON METAL DECK DETAIL VALID FOR DEMANDS SHOWN AT ANY ELEVATION IN THE BUILDING. (i.e.  $z/h \leq 1$ )
8. CONCRETE SLAB DETAIL VALID FOR DEMANDS SHOWN AT OR BELOW GRADE. (i.e.  $z/h = 0$ )

**9. RESPONSIBILITIES OF THE STRUCTURAL ENGINEER OF RECORD OF THE BUILDING**

- A. PROVIDE SUPPORTING STRUCTURE TO SUPPORT WEIGHTS AND FORCES SHOWN IN ADDITION TO ALL OTHER LOADS.
- B. VERIFY THAT THE INSTALLATION IS IN CONFORMANCE WITH THE 2019 CBC AND WITH THE DETAILS, MATERIAL AND GAGE OF THE UNIT WHERE ATTACHMENTS ARE MADE AGREE WITH THE INFORMATION SHOWN ON THE PREAPPROVAL DOCUMENTS.
- C. VERIFY THAT PROJECT SPECIFIC VALUES OF  $S_{ds}$  &  $z/h$  RESULT IN SEISMIC FORCES ( $E_h$ ,  $E_v$ ) THAT DO NOT EXCEED THE VALUES ON THE DETAILS.
- D. VERIFY THAT THE CONCRETE SLAB TO WHICH THE EQUIPMENT IS ANCHORED MEETS THE REQUIREMENTS OF THE APPLICABLE ICC ESR REPORT. AND THIS OPM.
- E. VERIFY THAT THE ANCHORS ARE AN ADEQUATE DISTANCE FROM ANY SLAB EDGES OR OPENINGS (SEE TYPICAL DETAIL ON SHEET 2).
- F. VERIFY THAT ALL NEW OR EXISTING ANCHORS ARE AN ADEQUATE DISTANCE FROM THE UNIT ATTACHMENTS AND CHECK FOR INTERACTION WHERE OTHER ANCHORS ARE WITHIN 18" OR  $6h_{ef}$  FROM THIS UNIT'S ANCHORS.



## AGFA HEALTHCARE CORP

### DR 800 RF TABLE

DES. **J. ROBERSON**

JOB NO. **11-2011**

DATE **7/23/21**

SHEET

**2**

OF **7** SHEETS

#### 10. EXPANSION ANCHORS:

- A. ATTACHMENT IS TO BE MADE WITH THE ANCHORS LISTED BELOW AND INSTALLED AS DESCRIBED IN THE CORRESPONDING ICC REPORT.

Anchor Diameter	Concrete Type	Min. f'c (psi)	Anchor Type	ICC Report No.	Min. Embed.	Min. Spacing	Min. Edge Dist.	Min. Conc. Thickness	Torque Test	Direct Tension Test
1/2"	Sand Light Weight	3000	Hilti Kwik Bolt TZ2	ESR-4266	2"	6.75"	12"	See Detail "A"	40 FT-LB	N/A
1/2"	Normal Weight	3000	Hilti Kwik Bolt TZ2	ESR-4266	3.25"	4"	21"	6"	50 FT-LB	2345 lb

- B. THIS PREAPPROVAL ALLOWS FOR UP TO A MAXIMUM OF 2 ADJACENT CONCRETE SLAB EDGES, 21" AWAY MINIMUM (i.e. - CORNER). SEE ADJACENT DETAIL FOR ADDITIONAL MINIMUM ALLOWABLE CONCRETE EDGE DISTANCES.

- C. TESTING AND SPECIAL INSPECTION OF EXPANSION ANCHORS SHALL BE PERFORMED BY AN APPROVED INDEPENDENT AGENCY EMPLOYED BY THE FACILITY OWNER PER CBC 1704A & 1910A.5 AND CAC 7-149. ALL REPORTS SHALL BE SENT TO THE INSPECTOR OF RECORD, OWNER AND THE ARCHITECT OR ENGINEER IN RESPONSIBLE CHARGE.

- (i) AFTER AT LEAST 24 HOURS HAVE ELAPSED SINCE INSTALLATION, DIRECT PULL TENSION TEST OR TORQUE TEST AT LEAST 50% OF THE ANCHORS.

- (ii) ACCEPTANCE CRITERIA:

- DIRECT TENSION TEST: THE ANCHOR SHOULD HAVE NO OBSERVABLE MOVEMENT AT THE TEST LOAD. A PRACTICAL WAY TO DETERMINE OBSERVABLE MOVEMENT IS THAT THE WASHER BECOMES LOOSE.
- TORQUE TEST: THE APPLICABLE TORQUE MUST BE ACHIEVED WITHIN THE FOLLOWING LIMITS: WEDGE TYPE : 1/2 TURN OF THE NUT

- (iii) IF ANY ANCHOR FAILS, TEST ALL ANCHORS.

- D. AVOID DAMAGING EXISTING STEEL REINFORCING IN CONCRETE SLAB WHEN INSTALLING CONCRETE EXPANSION ANCHORS.

- E. PROVIDE FOR FULL THREAD ENGAGEMENT OF NUT & WASHER.

#### 11. BOLTS THROUGH CONCRETE ON METAL DECK

- A. BOLTS SHALL BE TORQUED BY 3/4 TURN OF THE NUTS AFTER THE SNUG TIGHT (THE SNUG-TIGHT CONDITION IS DEFINED AS THE TIGHTNESS REQUIRED TO BRING THE CONNECTED PLIES INTO FIRM CONTACT) CONDITION IS ACHIEVED, UNLESS OTHERWISE NOTED.
- B. THROUGH BOLT HOLES SHALL BE 1/16" LARGER THAN BOLT SIZE (HOLE SIZE = BOLT SIZE + 1/16) FOR CONCRETE.
- C. THROUGH-BOLTS IN CONCRETE SHALL RECEIVE SPECIAL INSPECTION AND TESTING (THROUGH BOLTS WITH STEEL TO STEEL CONNECTION IN TENSION DO NOT REQUIRE TENSION TESTING) IN ACCORDANCE WITH REQUIREMENTS FOR POST-INSTALLED ANCHORS.

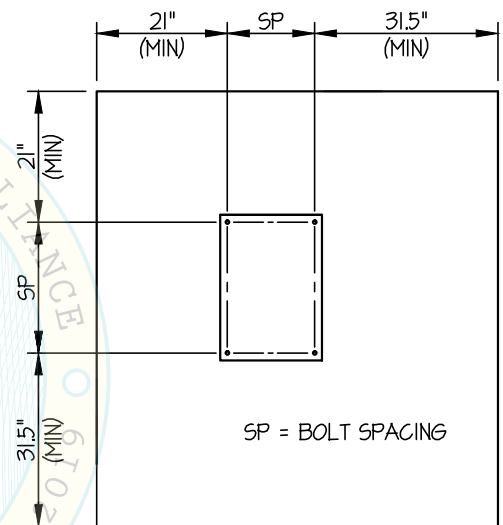

TYPICAL CONCRETE EDGE DETAIL

DATE: 10/08/2021



### AGFA HEALTHCARE CORP

### DR 800 RF TABLE

DES. J. ROBERSON

JOB NO. 11-2011

DATE 7/23/21

SHEET

3

OF 7 SHEETS

SEISMIC SUPPORTS & ATTACHMENTS

CONCRETE SLAB

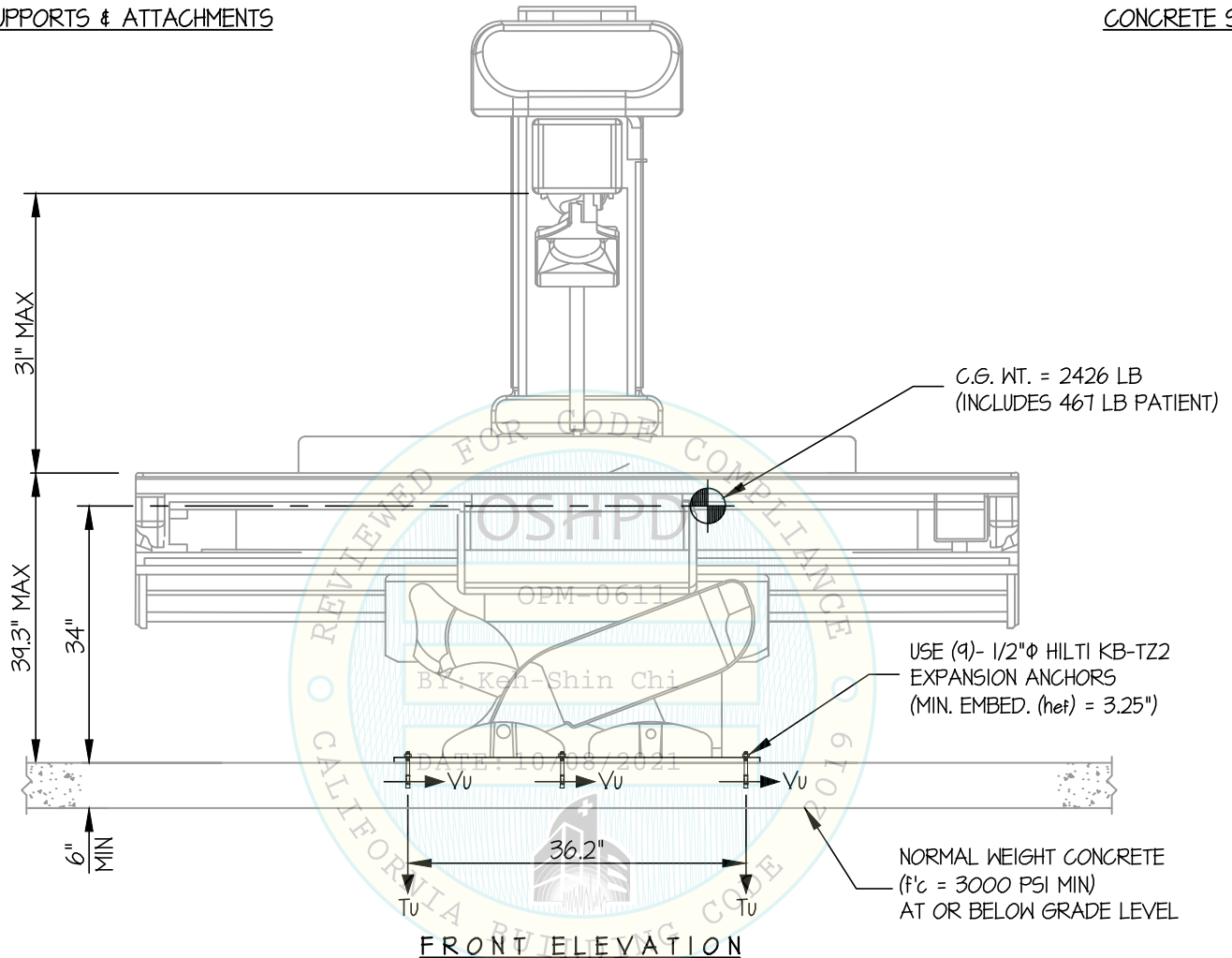

FRONT ELEVATION

**NOTES:**

1. FORCES ARE DETERMINED PER 2019 CALIFORNIA BUILDING CODE AND ASCE 7-16.

STRENGTH DESIGN IS USED. ( $S_Ds = 1.10$ ,  $a_p = 1.0$ ,  $I_p = 1.5$ ,  $R_p = 1.5$ ,  $\Omega_o = 2.0$ ,  $z/h = 0$ )

HORIZONTAL FORCE ( $E_h$ ) =  $0.495 W_p$

HORIZONTAL FORCE ( $E_{mh}$ ) =  $0.99 W_p$  (FOR CONCRETE ANCHORAGE)

VERTICAL FORCE ( $E_v$ ) =  $0.22 W_p$

$T_u = 1667$  LB/BOLT (MAX)

$V_u = 547$  LB/BOLT (MAX)

(VALUES INCLUDE  $\Omega_o$ )

2. CENTER OF GRAVITY (C.G.) AND WEIGHT ARE THE GOVERNING PARAMETERS FOR DESIGN. THIS PREAPPROVAL ENCOMPASSES ALL WEIGHTS UP TO THE MAXIMUM WEIGHT SHOWN.

3. STRUCTURAL ENGINEER OF RECORD FOR THE BUILDING SHALL PROVIDE SUPPORT STRUCTURE DESIGNED TO SUPPORT WEIGHTS AND FORCES SHOWN IN COMBINATION WITH ALL OTHER LOADS THAT MAY BE PRESENT.

4. DR 800 RF TABLE (UJT-17) HAS OBTAINED SPECIAL SEISMIC CERTIFICATION REFER TO OSP-0526.

5. SEE GENERAL NOTES: SHEETS 1 AND 2



### AGFA HEALTHCARE CORP

### DR 800 RF TABLE

DES. J. ROBERSON

JOB NO. 11-2011

DATE 7/23/21

SHEET

4

OF 7 SHEETS

SEISMIC SUPPORTS & ATTACHMENTS

CONCRETE SLAB

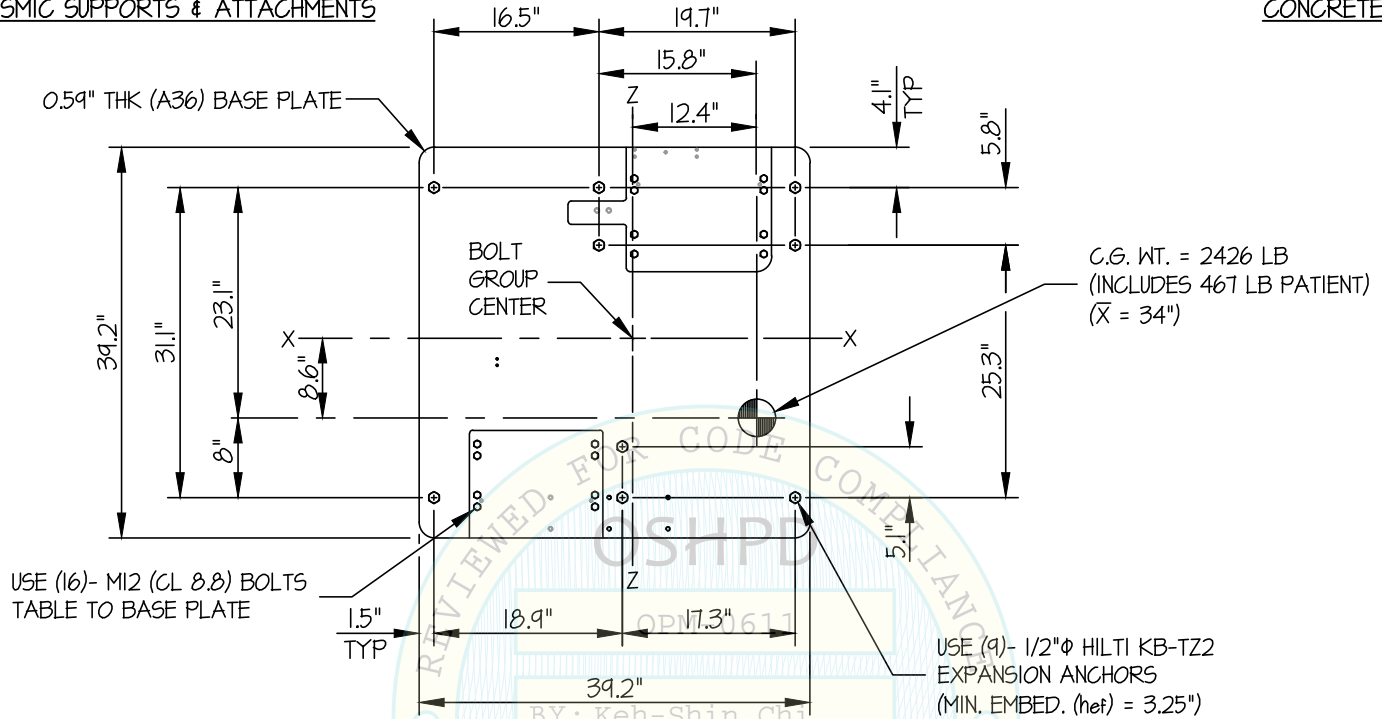

PLAT AT BASE

DATE: 10/08/2021

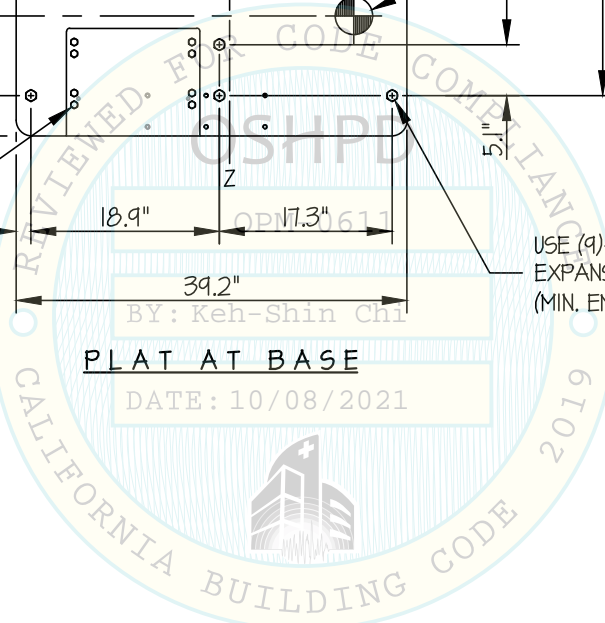

*Jonathan Roberson*  
 REGISTERED PROFESSIONAL ENGINEER  
 JONATHAN ROBERSON  
 No. 4197  
 EXP. 6-30-2022  
 7/23/21  
 STRUCTURAL  
 STATE OF CALIFORNIA

### AGFA HEALTHCARE CORP

DES. J. ROBERSON

SHEET

5

### DR 800 RF TABLE

JOB NO. 11-2011

DATE 7/23/21

OF 7 SHEETS

SEISMIC SUPPORTS & ATTACHMENTS

CONCRETE SLAB ON METAL DECK

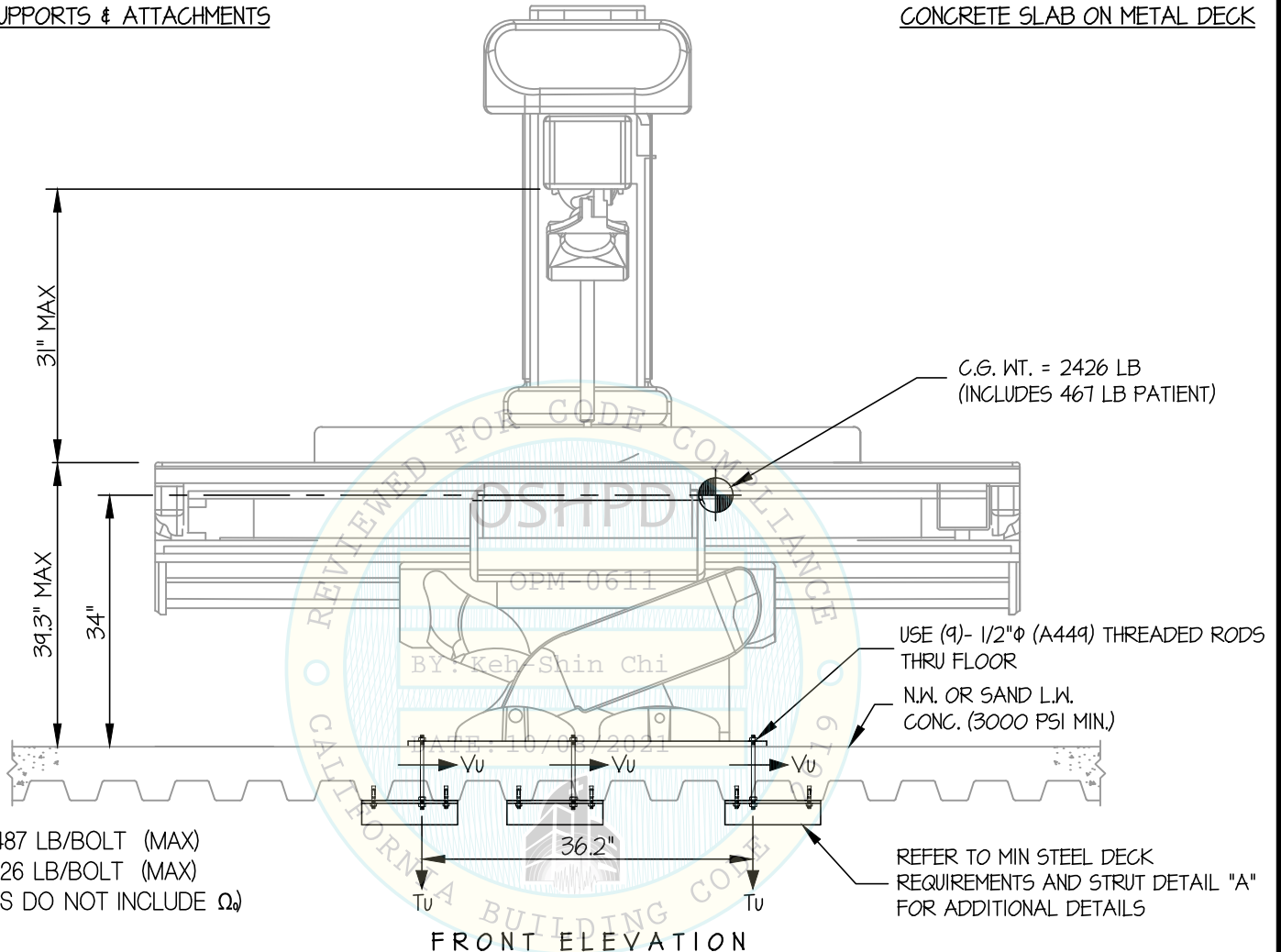

$T_u = 3487$  LB/BOLT (MAX)  
 $V_u = 1326$  LB/BOLT (MAX)  
 (VALUES DO NOT INCLUDE  $\Omega$ )

USE (9)- 1/2"  $\phi$  (A449) THREADED RODS THRU FLOOR  
 N.W. OR SAND L.W. CONG. (3000 PSI MIN.)

REFER TO MIN STEEL DECK REQUIREMENTS AND STRUT DETAIL "A" FOR ADDITIONAL DETAILS

**NOTES:**

1. FORCES ARE DETERMINED PER 2019 CALIFORNIA BUILDING CODE AND ASCE 7-16.

STRENGTH DESIGN IS USED. ( $S_{bs} = 2.00$ ,  $a_p = 1.0$ ,  $l_p = 1.5$ ,  $R_p = 1.5$ ,  $\Omega_o = 2.0$ ,  $z/h \leq 1$ )

HORIZONTAL FORCE ( $E_h$ ) =  $2.40 W_p$

HORIZONTAL FORCE ( $E_{mh}$ ) =  $4.80 W_p$  (FOR CONCRETE ANCHORAGE)

VERTICAL FORCE ( $E_v$ ) =  $0.40 W_p$

2. CENTER OF GRAVITY (C.G.) AND WEIGHT ARE THE GOVERNING PARAMETERS FOR DESIGN. THIS PREAPPROVAL ENCOMPASSES ALL WEIGHTS UP TO THE MAXIMUM WEIGHT SHOWN.

3. STRUCTURAL ENGINEER OF RECORD FOR THE BUILDING SHALL PROVIDE SUPPORT STRUCTURE DESIGNED TO SUPPORT WEIGHTS AND FORCES SHOWN IN COMBINATION WITH ALL OTHER LOADS THAT MAY BE PRESENT.

4. DR 800 RF TABLE (UUT-17) HAS OBTAINED SPECIAL SEISMIC CERTIFICATION REFER TO OSP-0526.

5. SEE GENERAL NOTES: SHEETS 1 AND 2



## AGFA HEALTHCARE CORP

### DR 800 RF TABLE

DES. **J. ROBERSON**

JOB NO. **11-2011**

DATE **7/23/21**

SHEET

**6**

OF **7** SHEETS

SEISMIC SUPPORTS & ATTACHMENTS

CONCRETE SLAB ON METAL DECK

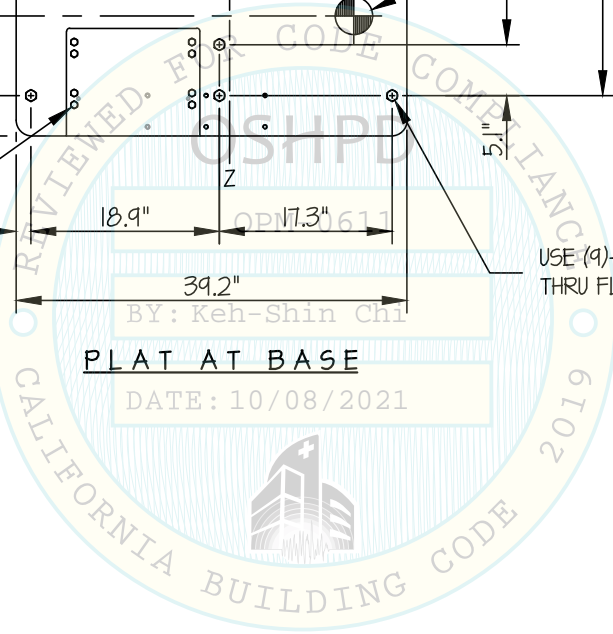
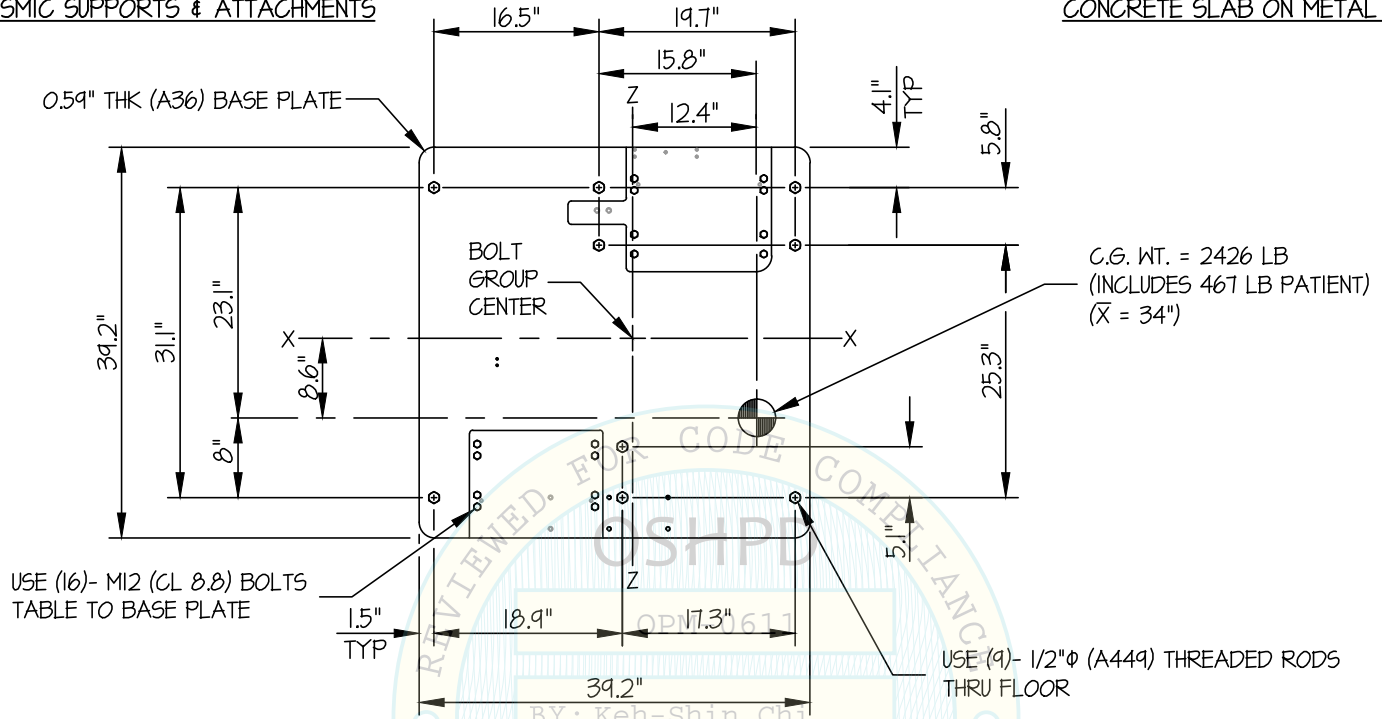

PLAT AT BASE

DATE: 10/08/2021

*Jonathan Roberson*



### AGFA HEALTHCARE CORP

### DR 800 RF TABLE

DES. J. ROBERSON

JOB NO. 11-2011

DATE 7/23/21

SHEET

7

OF 7 SHEETS

SEISMIC SUPPORTS & ATTACHMENTS

CONCRETE DETAIL

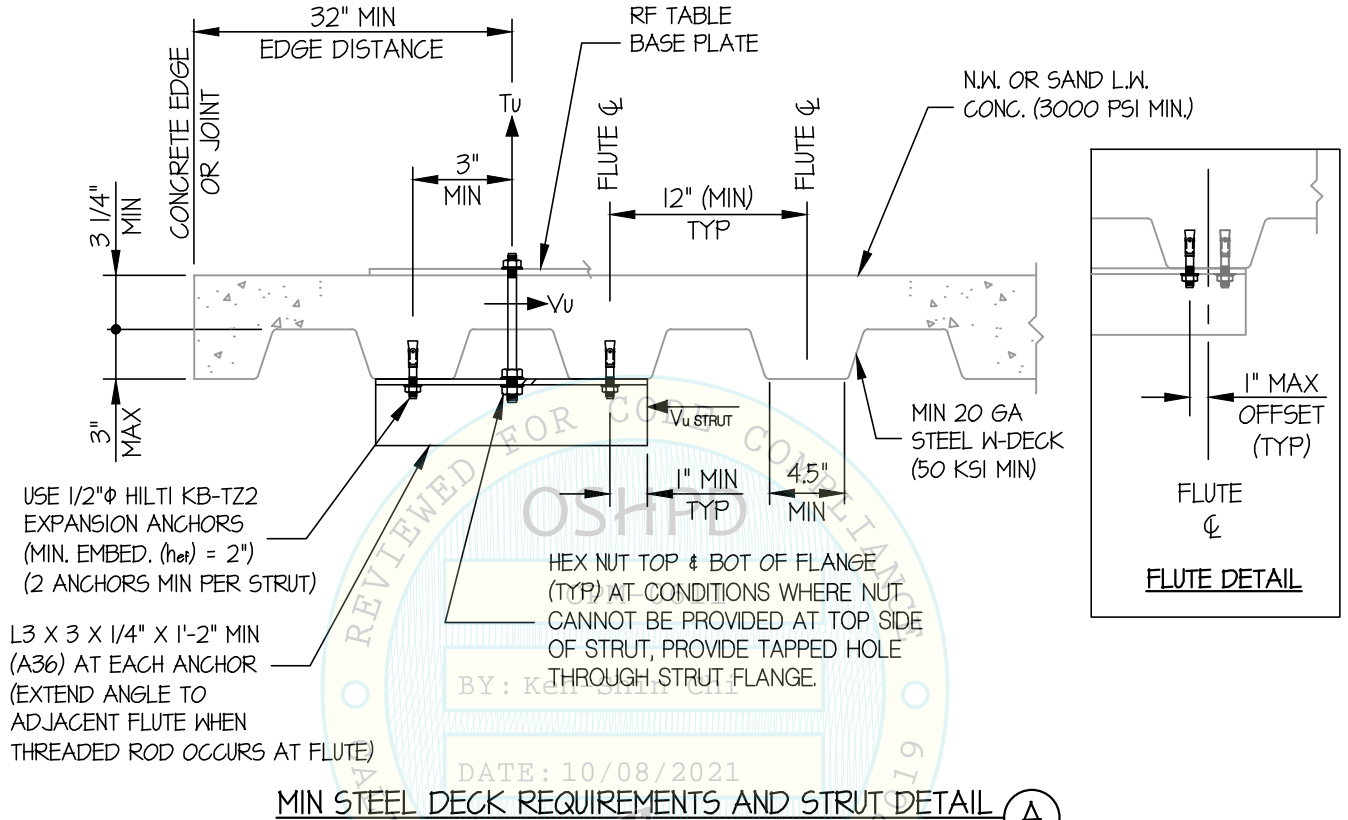

*Jonathan Roberson*

REGISTERED PROFESSIONAL ENGINEER  
JONATHAN ROBERSON  
No. 4197  
EXP. 6-30-2022  
7/23/21  
STRUCTURAL  
STATE OF CALIFORNIA