



DEPARTMENT OF HEALTH CARE ACCESS AND INFORMATION  
FACILITIES DEVELOPMENT DIVISION

APPLICATION FOR HCAI PREAPPROVAL OF  
MANUFACTURER'S CERTIFICATION (OPM)

OFFICE USE ONLY

APPLICATION #: OPM-0636

HCAI Preapproval of Manufacturer's Certification (OPM)

Type:  New  Renewal/Update

Manufacturer Information

Manufacturer: Getinge Disinfection AB

Manufacturer's Technical Representative: Peter Blomqvist

Mailing Address: Ljungadalsgatan11, Vaxjo, SW 35246

Telephone: (461) 033-5985

Email: peter.blomqvist@getinge.com

Product Information

Product Name: Getinge Aquadi 56, Washer-Disinfector OPM-0636

Product Type: Other Electrical & Mechanical Components

Product Model Number: 56M, 56A

General Description: Washer/Disinfector for medical instruments and glassware

Applicant Information

Applicant Company Name: EASE LLC.

Contact Person: Tiffany Tonn

Mailing Address: 1515 FAIRVIEW AVE, STE 205, MISSOULA, MT 59801

Telephone: (406) 541-3273

Email: tiffany@easeco.com

Title: Office Manager

"A healthier California where all receive equitable, affordable, and quality healthcare"

STATE OF CALIFORNIA – HEALTH AND HUMAN SERVICES AGENCY





DEPARTMENT OF HEALTH CARE ACCESS AND INFORMATION
FACILITIES DEVELOPMENT DIVISION

Registered Design Professional Preparing Engineering Recommendations

Company Name: EASE LLC
Name: Jonathan Roberson California License Number: S4197
Mailing Address: 5877 Pine Ave., Suite 210, Chino Hills, CA 91709
Telephone: (951) 295-1892 Email: jon@EASECo.com

HCAI Special Seismic Certification Preapproval (OSP)

Special Seismic Certification is preapproved under OSP OSP Number:

Certification Method

Testing in accordance with: ICC-ES AC156 FM 1950-16
Other(s) (Please Specify):

\*Use of criteria other than those adopted by the California Building Standards Code, 2022 (CBSC 2022) for component supports and attachments are not permitted. For distribution system, interior partition wall, and suspended ceiling seismic bracings, test criteria other than those adopted in the CBSC 2022 may be used when approved by HCAI prior to testing.

- Analysis
Experience Data
Combination of Testing, Analysis, and/or Experience Data (Please Specify):

HCAI Approval

Date: 7/6/2023
Name: William Staehlin Title: Senior Structural Engineer
Condition of Approval (if applicable):



**EQUIPMENT ANCHORAGE  
& SEISMIC ENGINEERING**

5877 Pine Ave, Ste. 210  
Chino Hills, CA. 91709  
Phn: (909) 606-7622

The Department of Health Care Access and Information  
**PREAPPROVAL OF MANUFACTURER'S CERTIFICATION**  
**OPM-0636**

**THIS PREAPPROVAL CONFORMS TO THE 2019 CALIFORNIA BUILDING CODE**

MANUFACTURER: **GETINGE USA**  
EQUIPMENT NAME: **GETINGE AQUADIS 56, WASHER/DISINFECTOR**

Sheet: 1 of 10

Date: 6/30/23

**GENERAL NOTES**

1. THIS HCAI PREAPPROVAL OF MANUFACTURER'S CERTIFICATION (OPM) IS BASED ON THE 2022 CBC. THE DEMANDS (DESIGN FORCES) FOR USE WITH THIS OPM SHALL BE BASED ON THE 2022 CBC
2. THIS DOCUMENT MAY ONLY BE USED WITH THE EXPRESS WRITTEN CONSENT OF THE MANUFACTURER LISTED ABOVE FOR THE SPECIFIC PROJECT SITE AND INSTALLATION LOCATION. THIS DOCUMENT IS INVALID WITHOUT SUCH CONSENT.
3. THIS PREAPPROVAL CONFORMS TO THE 2022 CALIFORNIA BUILDING CODE WHERE  $S_{Ds}$  IS NOT GREATER THAN 2.30.
4. FORCES PER ASCE 7-16 SECTION 13.3.1, EQUATIONS 13.3-1, 13.3-2 & 13.3-3, WHERE  $S_{Ds} = 2.30$ ,  $a_p = 1.0$ ,  $I_p = 1.5$ ,  $R_p = 1.5$ ,  $z/h = 0$  AT CONCRETE SLAB &  $z/h \leq 1$  AT CONCRETE SLAB ON METAL DECK. SEE FOLLOWING SHEETS FOR  $\Omega_e$ .
5. THIS PREAPPROVAL COVERS ONLY THE SUPPORTS AND ATTACHMENTS OF THE EQUIPMENT TO THE STRUCTURE.
6. ALL DESIGN FORCES SHOWN ON THE DRAWINGS ARE FACTORED LOADS THAT SHALL BE USED FOR STRENGTH DESIGN.
7. CONCRETE SLAB ON METAL DECK DETAIL VALID FOR DEMANDS SHOWN AT ANY ELEVATION IN THE BUILDING. (i.e.  $z/h \leq 1$ )
8. CONCRETE SLAB DETAIL VALID FOR DEMANDS SHOWN AT OR BELOW GRADE. (i.e.  $z/h = 0$ )

**9. RESPONSIBILITIES OF THE STRUCTURAL ENGINEER OF RECORD OF THE BUILDING**

- A. PROVIDE SUPPORTING STRUCTURE TO SUPPORT WEIGHTS AND FORCES SHOWN IN ADDITION TO ALL OTHER LOADS.
- B. VERIFY THAT THE INSTALLATION IS IN CONFORMANCE WITH THE 2022 CBC AND WITH THE DETAILS, MATERIAL AND GAGE OF THE UNIT WHERE ATTACHMENTS ARE MADE AGREE WITH THE INFORMATION SHOWN ON THE PREAPPROVAL DOCUMENTS.
- C. VERIFY THAT PROJECT SPECIFIC VALUES OF  $S_{Ds}$  &  $z/h$  RESULT IN SEISMIC FORCES ( $E_h$ ,  $E_v$ ) THAT DO NOT EXCEED THE VALUES ON THE DETAILS.
- D. VERIFY THAT THE CONCRETE SLAB TO WHICH THE EQUIPMENT IS ANCHORED MEETS THE REQUIREMENTS OF THE APPLICABLE ICC ESR REPORT. AND THIS OPM.
- E. VERIFY THAT THE ANCHORS ARE AN ADEQUATE DISTANCE FROM ANY SLAB EDGES OR OPENINGS (SEE TYPICAL DETAIL ON SHEET 2).
- F. VERIFY THAT ALL NEW OR EXISTING ANCHORS ARE AN ADEQUATE DISTANCE FROM THE UNIT ATTACHMENTS AND CHECK FOR INTERACTION WHERE OTHER ANCHORS ARE WITHIN 18" OR  $6h_{ef}$  FROM THIS UNIT'S ANCHORS.



## GETINGE USA

DES. **J. ROBERSON**

SHEET

**2**

JOB NO. **36-2304**

## GETINGE AQUADIS 56, WASHER/DISINFECTOR

DATE **6/30/23**

OF **10** SHEETS

### 10. EXPANSION ANCHORS:

A. ATTACHMENT IS TO BE MADE WITH THE ANCHORS LISTED BELOW AND INSTALLED AS DESCRIBED IN THE CORRESPONDING ICC REPORT.

Anchor Diameter	Concrete Type	Min. f'c (psi)	Anchor Type	ICC Report No.	Min. Embed.	Min. Spacing	Min. Edge Dist.	Min. Conc. Thickness	Torque Test	Direct Tension Test
3/8"	Sand Light Weight	3000	Hilti Kwik Bolt TZ2 (CARBON STEEL)	ESR-4266	2"	6.75"	12"	See Detail "A"	30 FT-LB	N/A
1/2"	Normal Weight	3000	Hilti Kwik Bolt TZ2 (CARBON STEEL)	ESR-4266	3.25"	10"	24"	6"	50 FT-LB	3324 lb

B. THIS PREAPPROVAL ALLOWS FOR UP TO A MAXIMUM OF 2 ADJACENT CONCRETE SLAB EDGES, 24" AWAY MINIMUM (i.e. - CORNER). SEE ADJACENT DETAIL FOR ADDITIONAL MINIMUM ALLOWABLE CONCRETE EDGE DISTANCES.

C. TESTING AND SPECIAL INSPECTION OF EXPANSION ANCHORS SHALL BE PERFORMED BY AN APPROVED INDEPENDENT AGENCY EMPLOYED BY THE FACILITY OWNER PER CBC 1704A & 1910A.5 AND CAC 7-149. ALL REPORTS SHALL BE SENT TO THE INSPECTOR OF RECORD, OWNER AND THE ARCHITECT OR ENGINEER IN RESPONSIBLE CHARGE.

(i) AFTER AT LEAST 24 HOURS HAVE ELAPSED SINCE INSTALLATION, DIRECT PULL TENSION TEST OR TORQUE TEST AT LEAST 50% OF THE ANCHORS.

(ii) ACCEPTANCE CRITERIA:

- DIRECT TENSION TEST: THE ANCHOR SHOULD HAVE NO OBSERVABLE MOVEMENT AT THE TEST LOAD. A PRACTICAL WAY TO DETERMINE OBSERVABLE MOVEMENT IS THAT THE WASHER BECOMES LOOSE.
- TORQUE TEST: THE APPLICABLE TORQUE MUST BE ACHIEVED WITHIN THE FOLLOWING LIMITS: WEDGE TYPE : 1/2 TURN OF THE NUT

(iii) IF ANY ANCHOR FAILS, TEST ALL ANCHORS.

D. AVOID DAMAGING EXISTING STEEL REINFORCING IN CONCRETE SLAB WHEN INSTALLING CONCRETE EXPANSION ANCHORS.

E. PROVIDE FOR FULL THREAD ENGAGEMENT OF NUT & WASHER.

### 11. BOLTS THROUGH CONCRETE ON METAL DECK

A. BOLTS SHALL BE TORQUED BY 3/4 TURN OF THE NUTS AFTER THE SNUG TIGHT (THE SNUG-TIGHT CONDITION IS DEFINED AS THE TIGHTNESS REQUIRED TO BRING THE CONNECTED PLIES INTO FIRM CONTACT) CONDITION IS ACHIEVED, UNLESS OTHERWISE NOTED.

B. THROUGH BOLT HOLES SHALL BE 1/16" LARGER THAN BOLT SIZE (HOLE SIZE = BOLT SIZE + 1/16) FOR CONCRETE.

C. THROUGH-BOLTS IN CONCRETE SHALL RECEIVE SPECIAL INSPECTION AND TESTING (THROUGH BOLTS WITH STEEL TO STEEL CONNECTION IN TENSION DO NOT REQUIRE TENSION TESTING) IN ACCORDANCE WITH REQUIREMENTS FOR POST-INSTALLED ANCHORS.

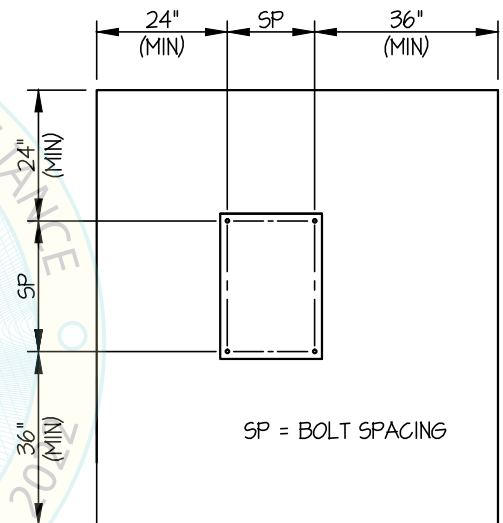

TYPICAL CONCRETE EDGE DETAIL  
(SLAB ON GRADE ONLY)



### GETINGE USA

DES. **J. ROBERSON**

SHEET

# 3

## GETINGE AQUADIS 56, WASHER/DISINFECTOR

JOB NO. **36-2304**

DATE **6/30/23**

OF **10** SHEETS

SEISMIC SUPPORTS & ATTACHMENTS

CONCRETE SLAB

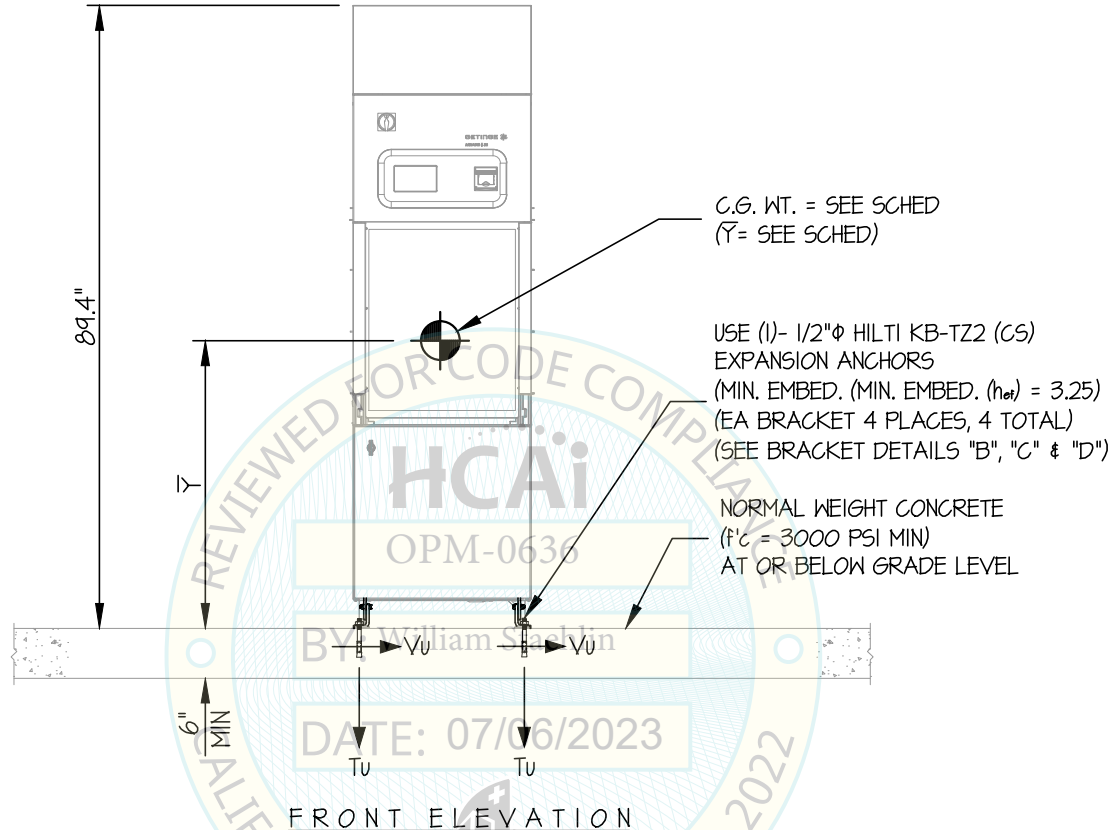

**NOTES:**

1. FORCES ARE DETERMINED PER 2022 CALIFORNIA BUILDING CODE AND ASCE 7-16. STRENGTH DESIGN IS USED. (EXAMPLE:  $S_{DS} = 2.30$ ,  $\alpha_p = 10$ ,  $I_p = 15$ ,  $R_p = 15$ ,  $\Omega_e = 2.0$ ,  $z/h = 0$ )

- HORIZONTAL FORCE ( $E_h$ ) = 1.035  $W_p$
- HORIZONTAL FORCE ( $E_{mh}$ ) = 2.07  $W_p$  (FOR CONCRETE ANCHORAGE)
- VERTICAL FORCE ( $E_v$ ) = 0.46  $W_p$

2. THIS PREAPPROVAL ENCOMPASSES WEIGHTS AND VERTICAL C.G. POSITIONS NOT EXCEEDING VALUES SHOWN.
3. THIS CALCULATION WAS PREPARED WITHOUT KNOWLEDGE OF ANY SITE CONDITION. COMPATIBILITY FOR USE WITH A SITE SHALL BE EVALUATED BY THE STRUCTURAL ENGINEER OF RECORD OF THE INSTALLATION (SEOR). USE REQUIRES APPROVAL BY THE SEOR.
4. STRUCTURAL ENGINEER OF RECORD FOR THE INSTALLATION SHALL VERIFY ALL CONDITIONS, EVALUATE INTERACTION WITH ADJACENT EQUIPMENT AND ANCHORS, AND PROVIDE SUPPORT STRUCTURE DESIGNED TO SUPPORT WEIGHTS AND FORCES SHOWN IN COMBINATION WITH ALL OTHER LOADS THAT MAY BE PRESENT.

4. SEE GENERAL NOTES; SHEETS 1 AND 2





### GETINGE USA

DES. **J. ROBERSON**

SHEET

# 4

## GETINGE AQUADIS 56, WASHER/DISINFECTOR

JOB NO. **36-2304**

DATE **6/30/23**

OF **10** SHEETS

SEISMIC SUPPORTS & ATTACHMENTS

CONCRETE SLAB

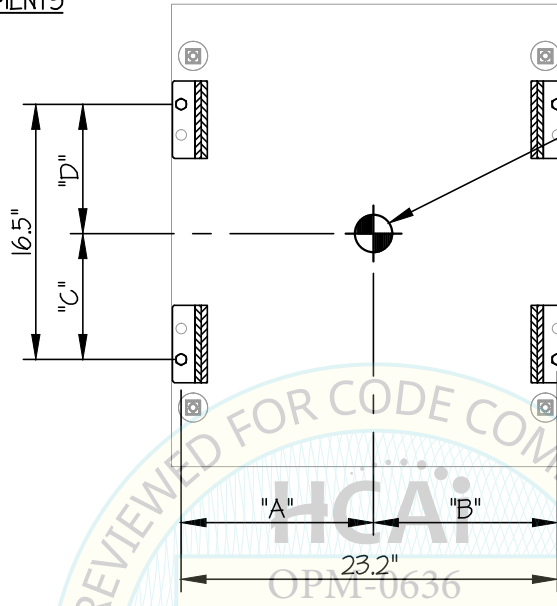

C.G. WT. = SEE SCHED  
( $\bar{Y}$  = SEE SCHED)

USE (1)- 1/2"  $\phi$  HILTI KB-TZ2 (CS)  
EXPANSION ANCHORS  
(MIN. EMBED. ( $h_{ef}$ ) = 3.25")  
(EA BRACKET 4 PLACES, 4 TOTAL)  
(SEE BRACKET DETAILS "B", "C" & "D")

PLAN AT BASE

UNIT SERIES	WEIGHT (lb.)	$\bar{Y}$ (in.)	"A" (in.)	"B" (in.)	"C" (in.)	"D" (in.)	$^+ T_u$ (lb.)	$^+ V_u$ (lb.)
GETINGE AQUADIS 56, MANUAL DOOR	547	37.6	11.4	11.8	8.1	8.4	1530	375
GETINGE AQUADIS 56, AUTOMATIC DOOR	630	39.8	11.3	11.9	8.4	8.1	1929	434

+ VALUES INCLUDE  $\Omega_0$



### GETINGE USA

DES. **J. ROBERSON**

SHEET

# 5

## GETINGE AQUADIS 56, WASHER/DISINFECTOR

JOB NO. **36-2304**

DATE **6/30/23**

OF **10** SHEETS

SEISMIC SUPPORTS & ATTACHMENTS

CONCRETE SLAB ON METAL DECK

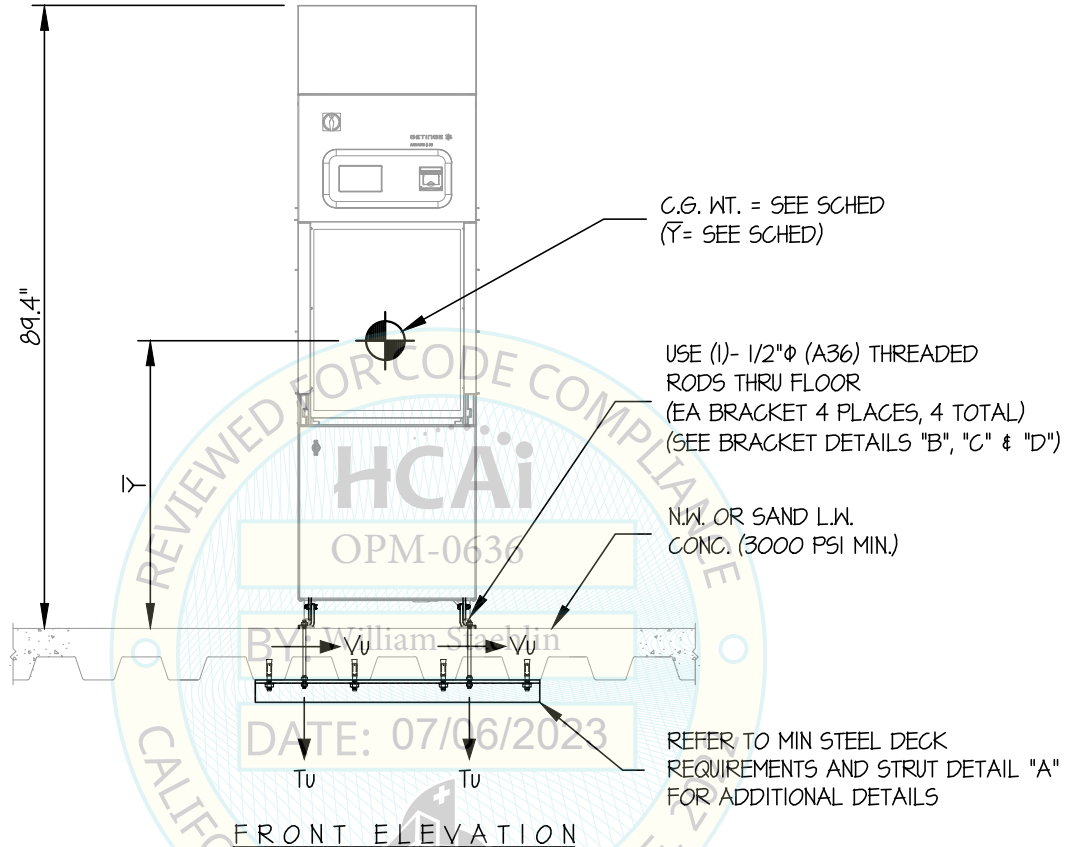

#### NOTES:

- FORCES ARE DETERMINED PER 2022 CALIFORNIA BUILDING CODE AND ASCE 7-16. STRENGTH DESIGN IS USED. (EXAMPLE:  $S_{DS} = 2.30$ ,  $a_p = 1.0$ ,  $I_p = 15$ ,  $R_p = 15$ ,  $\Omega_o = 2.0$ ,  $z/h \leq 1$ )
 

HORIZONTAL FORCE ( $E_h$ )	=	2.76 $W_p$
HORIZONTAL FORCE ( $E_{mh}$ )	=	5.52 $W_p$ (FOR CONCRETE ANCHORAGE)
VERTICAL FORCE ( $E_v$ )	=	0.46 $W_p$
- THIS PREAPPROVAL ENCOMPASSES WEIGHTS AND VERTICAL C.G. POSITIONS NOT EXCEEDING VALUES SHOWN.
- THIS CALCULATION WAS PREPARED WITHOUT KNOWLEDGE OF ANY SITE CONDITION. COMPATIBILITY FOR USE WITH A SITE SHALL BE EVALUATED BY THE STRUCTURAL ENGINEER OF RECORD OF THE INSTALLATION (SEOR). USE REQUIRES APPROVAL BY THE SEOR.
- STRUCTURAL ENGINEER OF RECORD FOR THE INSTALLATION SHALL VERIFY ALL CONDITIONS, EVALUATE INTERACTION WITH ADJACENT EQUIPMENT AND ANCHORS, AND PROVIDE SUPPORT STRUCTURE DESIGNED TO SUPPORT WEIGHTS AND FORCES SHOWN IN COMBINATION WITH ALL OTHER LOADS THAT MAY BE PRESENT.
- SEE GENERAL NOTES: SHEETS 1 AND 2



**GETINGE USA**

DES. **J. ROBERSON**

SHEET

**6**

**GETINGE AQUADIS 56,  
WASHER/DISINFECTOR**

JOB NO. **36-2304**

DATE **6/30/23**

OF **10** SHEETS

SEISMIC SUPPORTS & ATTACHMENTS

CONCRETE SLAB ON METAL DECK

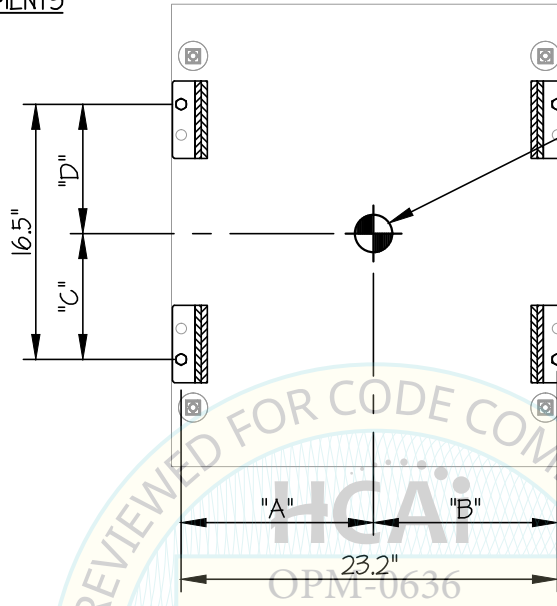

C.G. WT. = SEE SCHED  
( $\bar{Y}$  = SEE SCHED)

USE (1)- 1/2"  $\phi$  (A36) THREADED  
RODS THRU FLOOR  
(EA BRACKET 4 PLACES, 4 TOTAL)  
(SEE BRACKET DETAILS "B", "C" & "D")

PLAN AT BASE

UNIT SERIES	WEIGHT (lb.)	$\bar{Y}$ (in.)	"A" (in.)	"B" (in.)	"C" (in.)	"D" (in.)	<sup>+</sup> T <sub>u</sub> (lb.)	<sup>+</sup> V <sub>u</sub> (lb.)
GETINGE AQUADIS 56, MANUAL DOOR	547	37.6	11.4	11.8	8.1	8.4	2061	500
GETINGE AQUADIS 56, AUTOMATIC DOOR	630	39.8	11.3	11.9	8.4	8.1	2619	579

+ VALUES INCLUDE  $\Omega_0$

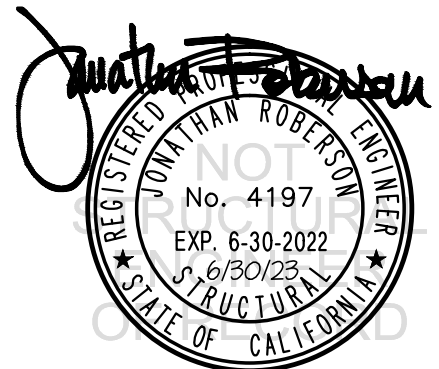



**GETINGE USA**

DES. **J. ROBERSON**

SHEET

**7**

**GETINGE AQUADIS 56,  
WASHER/DISINFECTOR**

JOB NO. **36-2304**

DATE **6/30/23**

OF **10** SHEETS

SEISMIC SUPPORTS & ATTACHMENTS

CONCRETE DETAIL

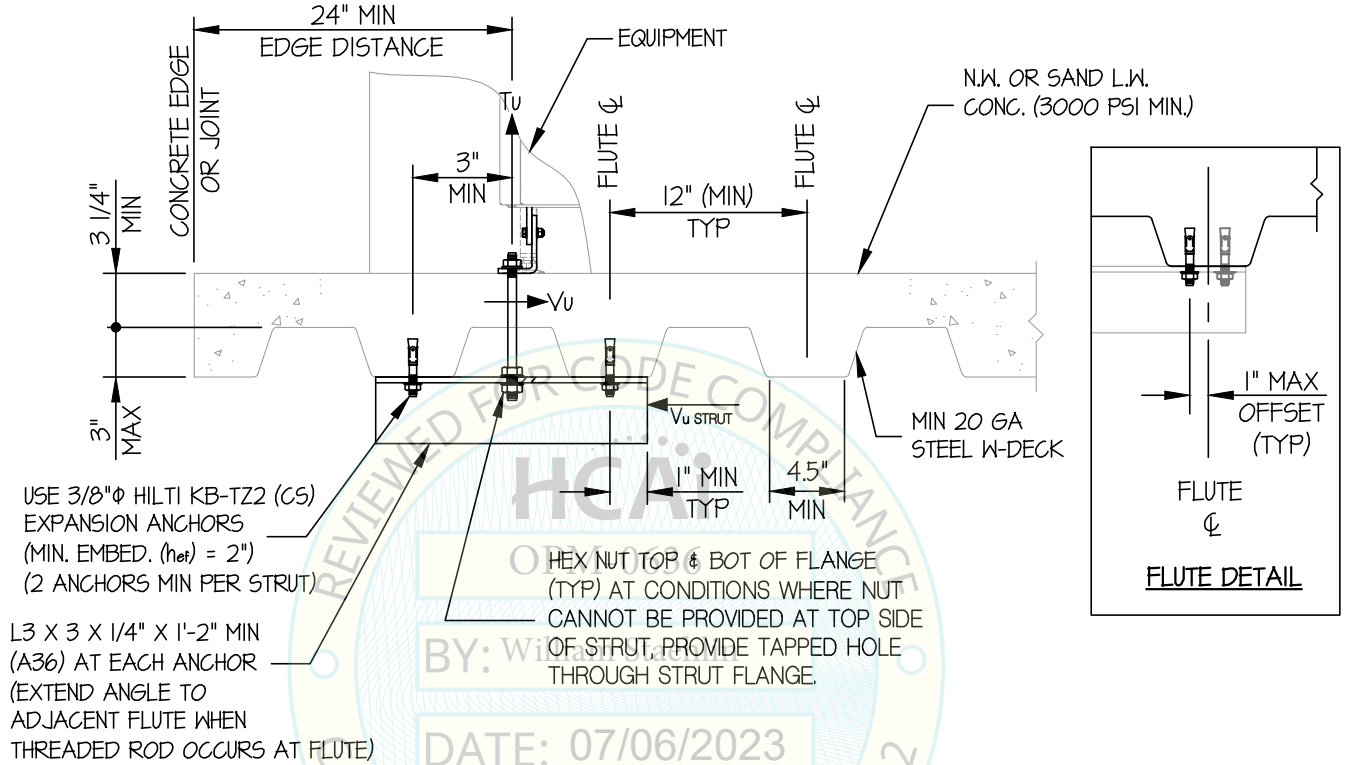

MIN STEEL DECK REQUIREMENTS AND STRUT DETAIL (A)

*Jonathan Roberson*

REGISTERED PROFESSIONAL ENGINEER  
JONATHAN ROBERSON  
No. 4197  
EXP. 6-30-2022  
6/30/23  
STRUCTURAL  
STATE OF CALIFORNIA

**GETINGE USA**

DES. **J. ROBERSON**

SHEET

**8**

**GETINGE AQUADIS 56,  
WASHER/DISINFECTOR**

JOB NO. **36-2304**

DATE **6/30/23**

OF **10** SHEETS

SEISMIC SUPPORTS & ATTACHMENTS

BRACKET DETAILS

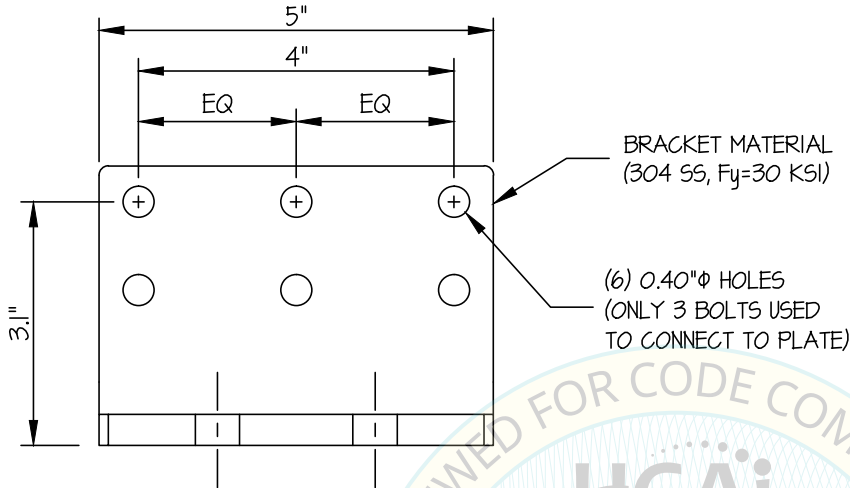

FRONT

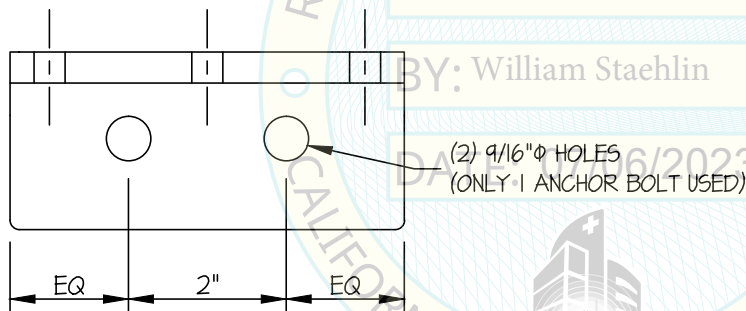

BRACKET DETAIL (B)

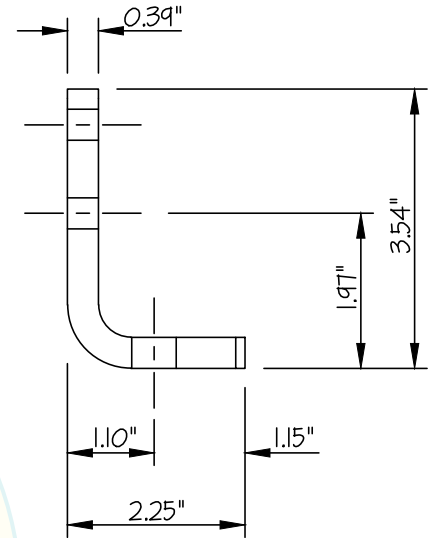

SIDE

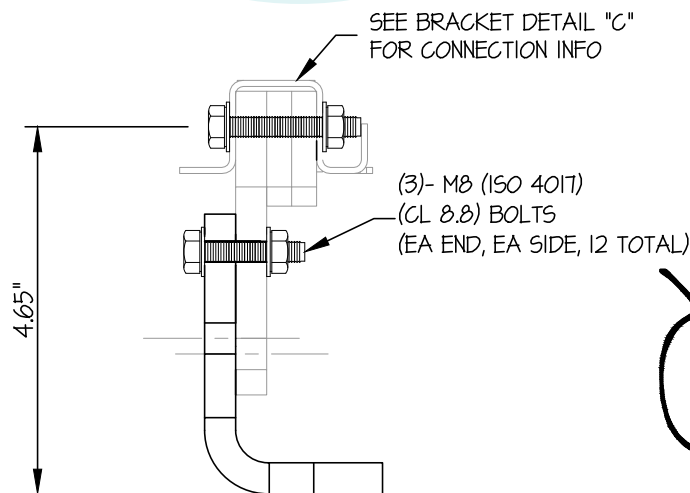
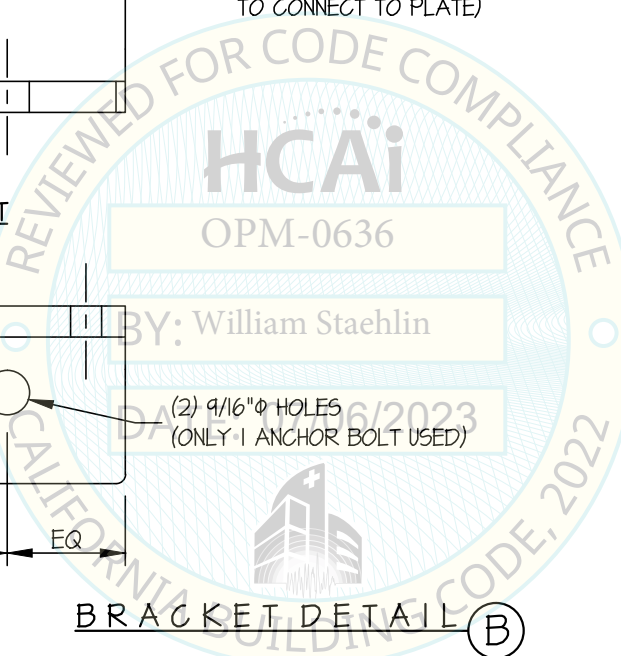

ASSEMBLY SIDE VIEW



### GETINGE USA

DES. J. ROBERSON

SHEET

# 9

## GETINGE AQUADIS 56, WASHER/DISINFECTOR

JOB NO. 36-2304

DATE 6/30/23

OF 10 SHEETS

SEISMIC SUPPORTS & ATTACHMENTS

BRACKET DETAILS

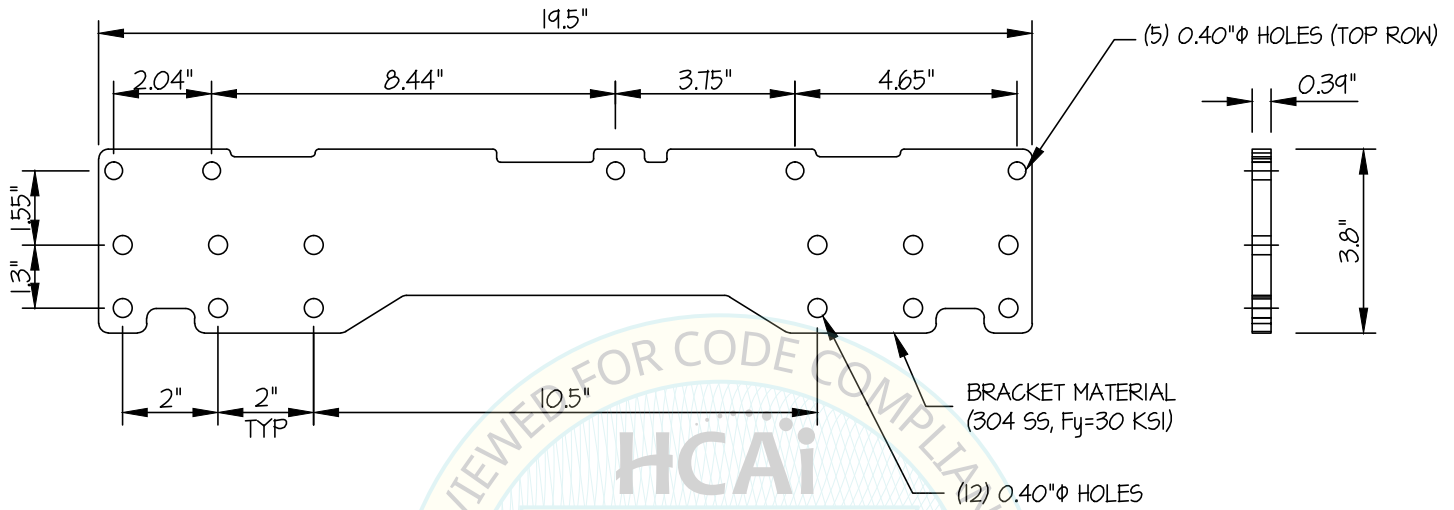

(5)- M8 (ISO 4017)  
(CL 8.8) BOLTS

UNIT FRAME  
(14 GA, A446,  $F_y=40$  KSI)

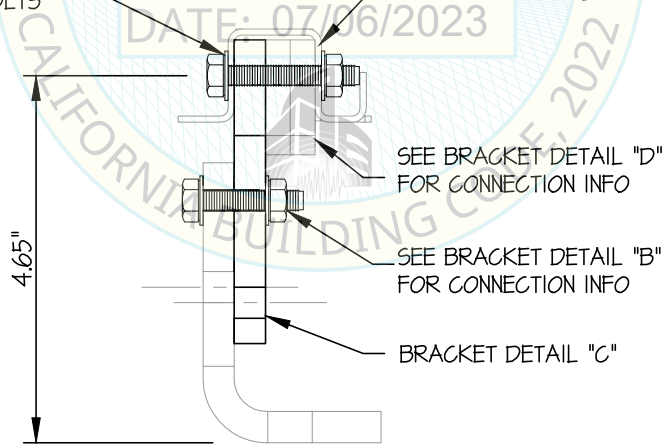

ASSEMBLY SIDE VIEW

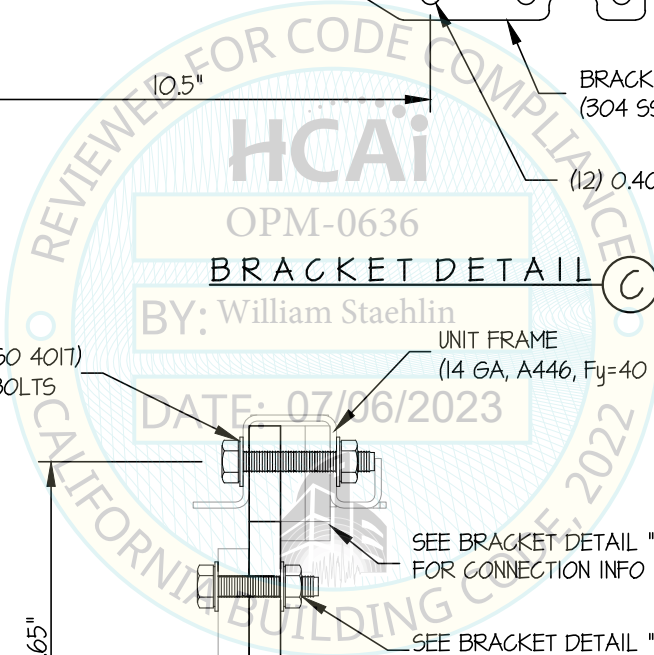

### GETINGE USA

DES. J. ROBERSON

SHEET

# 10

## GETINGE AQUADIS 56, WASHER/DISINFECTOR

JOB NO. 36-2304

DATE 6/30/23

OF 10 SHEETS

SEISMIC SUPPORTS & ATTACHMENTS

BRACKET DETAILS

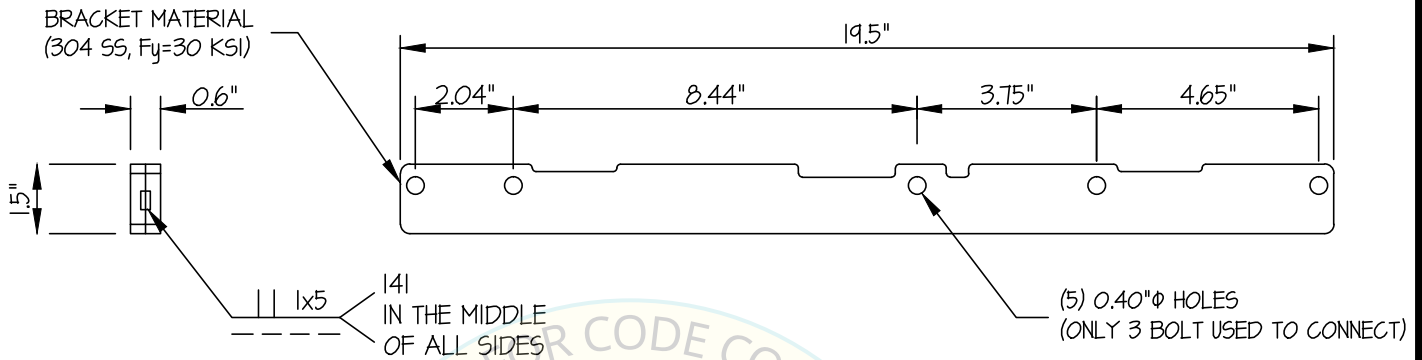

### BRACKET DETAIL D

OPM-0636

BY: William Staehlin

DATE: 07/06/2023

(5)- M8 (ISO 4017)  
(CL 8.8) BOLTS

UNIT FRAME  
(14 GA, A446, Fy=40 KSI)

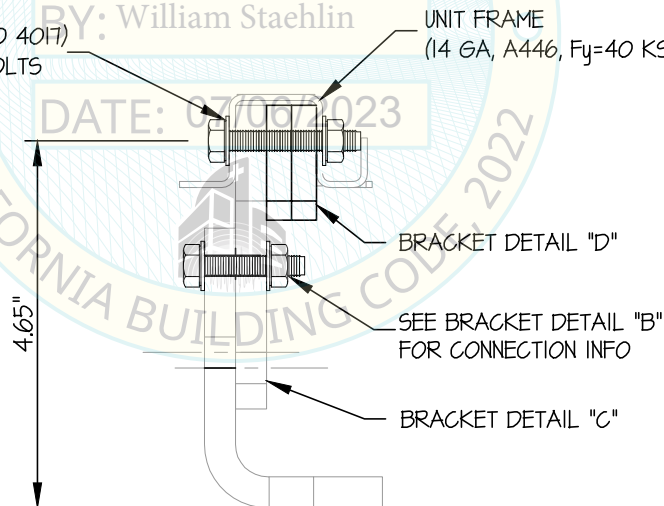

### ASSEMBLY SIDE VIEW

