



**OFFICE OF STATEWIDE HEALTH PLANNING AND DEVELOPMENT
FACILITIES DEVELOPMENT DIVISION**

**APPLICATION FOR OSHPD PREAPPROVAL OF
MANUFACTURER'S CERTIFICATION (OPM)**

OFFICE USE ONLY

APPLICATION #: OPM-0648

OSHPD Preapproval of Manufacturer's Certification (OPM)

Type: New Renewal/Update

Manufacturer Information

Manufacturer: Carestream Health

Manufacturer's Technical Representative: Christopher Kralles

Mailing Address: 1049 Ridge Road West, Rochester, NY 14615

Telephone: (585) 506-2164

Email: christopher.kralles@carestreamhealth.com

Product Information

Product Name: DRX-Compass Generator

Product Type: Other Electrical & Mechanical Components Radiology Imaging System

Product Model Number: N/A

General Description: Provides Electrical Power to Fluoroscopy & General

Applicant Information

Applicant Company Name: EASE LLC.

Contact Person: Tiffany Tonn

Mailing Address: 1515 FAIRVIEW AVE, STE 205, MISSOULA, MT 59801

Telephone: (406) 541-3273

Email: tiffany@easeco.com

Title: Office Manager

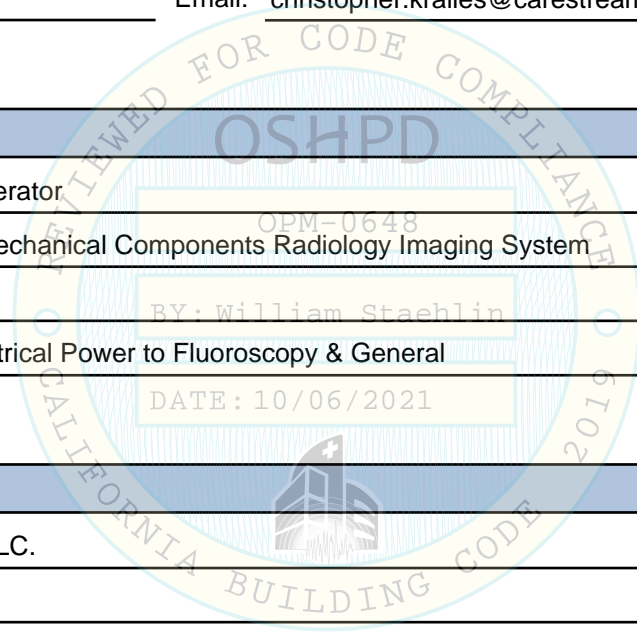



**OFFICE OF STATEWIDE HEALTH PLANNING AND DEVELOPMENT
FACILITIES DEVELOPMENT DIVISION**

Registered Design Professional Preparing Engineering Recommendations

Company Name: EASE

Name: Jonathan Roberson

California License Number: S4197

Mailing Address: 5877 Pine Ave., Suite 210, Chino Hills, CA 91709

Telephone: (951) 295-1892

Email: jon@EASECo.com

OSHPD Special Seismic Certification Preapproval (OSP)

Special Seismic Certification is preapproved under OSP

OSP Number: OSP-0703

Certification Method

Testing in accordance with: ICC-ES AC156 FM 1950-16

Other(s) (Please Specify): _____

*Use of criteria other than those adopted by the California Building Standards Code, 2019 (CBSC 2019) for component supports and attachments are not permitted. For distribution system, interior partition wall, and suspended ceiling seismic bracings, test criteria other than those adopted in the CBSC 2019 may be used when approved by OSHPD prior to testing.

Analysis

Experience Data

Combination of Testing, Analysis, and/or Experience Data (Please Specify): _____

OSHPD Approval

Date: 10/6/2021

Name: William Staehlin

Title: Senior Structural Engineer

Condition of Approval (if applicable): _____





**EQUIPMENT ANCHORAGE
& SEISMIC ENGINEERING**

5877 Pine Ave, Ste. 210
Chino Hills, CA. 91709
Phn: (909) 606-7622

Office of Statewide Health Planning and Development
PREAPPROVAL OF MANUFACTURER'S CERTIFICATION
OPM-0648

THIS PREAPPROVAL CONFORMS TO THE 2019 CALIFORNIA BUILDING CODE

MANUFACTURER: **CARESTREAM HEALTH, INC**
EQUIPMENT NAME: **COMPASS SYSTEM GENERATOR**

Sheet: 1 of 6
Date: 10/1/21

GENERAL NOTES

1. THIS OSHPD PREAPPROVAL OF MANUFACTURER'S CERTIFICATION (OPM) IS BASED ON THE 2019 CBC. THE DEMANDS (DESIGN FORCES) FOR USE WITH THIS OPM SHALL BE BASED ON THE 2019 CBC
2. THIS DOCUMENT MAY ONLY BE USED WITH THE EXPRESS WRITTEN CONSENT OF THE MANUFACTURER LISTED ABOVE FOR THE SPECIFIC PROJECT SITE AND INSTALLATION LOCATION. THIS DOCUMENT IS INVALID WITHOUT SUCH CONSENT.
3. THIS PREAPPROVAL CONFORMS TO THE 2019 CALIFORNIA BUILDING CODE WHERE S_{ds} IS NOT GREATER THAN 2.00 & 2.30. SEE DETAIL FOR APPLICABILITY
4. FORCES PER ASCE 7-16 SECTION 13.3.1, EQUATIONS 13.3-1, 13.3-2 & 13.3-3,
WHERE $S_{ds} = 2.30$, $a_p = 2.5$, $I_p = 1.5$, $R_p = 6.0$, $z/h = 0$ AT CONCRETE SLAB. SEE FOLLOWING SHEETS FOR Ω_o
WHERE $S_{ds} = 2.00$, $a_p = 2.5$, $I_p = 1.5$, $R_p = 6.0$, $z/h = 0$ AT CONCRETE SLAB & $z/h \leq 1$ AT CONCRETE SLAB ON METAL DECK.
SEE FOLLOWING SHEETS FOR Ω_o .
5. THIS PREAPPROVAL COVERS ONLY THE SUPPORTS AND ATTACHMENTS OF THE EQUIPMENT TO THE STRUCTURE.
6. ALL DESIGN FORCES SHOWN ON THE DRAWINGS ARE FACTORED LOADS THAT SHALL BE USED FOR STRENGTH DESIGN.
7. CONCRETE SLAB ON METAL DECK DETAIL VALID FOR DEMANDS SHOWN AT ANY ELEVATION IN THE BUILDING. (i.e. $z/h \leq 1$)
8. CONCRETE SLAB DETAIL VALID FOR DEMANDS SHOWN AT OR BELOW GRADE. (i.e. $z/h = 0$)

9. RESPONSIBILITIES OF THE STRUCTURAL ENGINEER OF RECORD OF THE BUILDING

- A. PROVIDE SUPPORTING STRUCTURE TO SUPPORT WEIGHTS AND FORCES SHOWN IN ADDITION TO ALL OTHER LOADS.
- B. VERIFY THAT THE INSTALLATION IS IN CONFORMANCE WITH THE 2019 CBC AND WITH THE DETAILS, MATERIAL AND GAGE OF THE UNIT WHERE ATTACHMENTS ARE MADE AGREE WITH THE INFORMATION SHOWN ON THE PREAPPROVAL DOCUMENTS.
- C. VERIFY THAT PROJECT SPECIFIC VALUES OF S_{ds} & z/h RESULT IN SEISMIC FORCES (E_h , E_v) THAT DO NOT EXCEED THE VALUES ON THE DETAILS.
- D. VERIFY THAT THE CONCRETE SLAB TO WHICH THE EQUIPMENT IS ANCHORED MEETS THE REQUIREMENTS OF THE APPLICABLE ICC ESR REPORT AND THIS OPM.
- E. VERIFY THAT THE ANCHORS ARE AN ADEQUATE DISTANCE FROM ANY SLAB EDGES OR OPENINGS (SEE TYPICAL DETAIL ON SHEET 2).
- F. VERIFY THAT ALL NEW OR EXISTING ANCHORS ARE AN ADEQUATE DISTANCE FROM THE UNIT ATTACHMENTS AND CHECK FOR INTERACTION WHERE OTHER ANCHORS ARE WITHIN 18" OR $6h_{ef}$ FROM THIS UNIT'S ANCHORS.



CARESTREAM HEALTH, INC

COMPASS SYSTEM GENERATOR

DES. **J. ROBERSON**

JOB NO. **11-2104**

DATE **10/1/21**

SHEET

2

OF **6** SHEETS

10. EXPANSION ANCHORS:

A. ATTACHMENT IS TO BE MADE WITH THE ANCHORS LISTED BELOW AND INSTALLED AS DESCRIBED IN THE CORRESPONDING ICC REPORT.

Anchor Diameter	Concrete Type	Min. f'c (psi)	Anchor Type	ICC Report No.	Min. Embed.	Min. Spacing	Min. Edge Dist.	Min. Conc. Thickness	Torque Test	Direct Tension Test
1/2"	Sand Light Weight	3000	Hilti Kwik Bolt TZ2 (CARBON STEEL)	ESR-4266	2"	9"	16"	3.25"	50 FT-LB	1190 lb
1/2"	Normal Weight	3000	Hilti Kwik Bolt TZ2 (CARBON STEEL)	ESR-4266	2"	8"	14"	4"	50 FT-LB	1983 lb

B. THIS PREAPPROVAL ALLOWS FOR UP TO A MAXIMUM OF 2 ADJACENT CONCRETE SLAB EDGES, 14" OR 16" AWAY MINIMUM (i.e. - CORNER). SEE ADJACENT DETAIL FOR ADDITIONAL MINIMUM ALLOWABLE CONCRETE EDGE DISTANCES.

C. TESTING AND SPECIAL INSPECTION OF EXPANSION ANCHORS SHALL BE PERFORMED BY AN APPROVED INDEPENDENT AGENCY EMPLOYED BY THE FACILITY OWNER PER CBC 1704A & 1910A.5 AND CAC 7-149. ALL REPORTS SHALL BE SENT TO THE INSPECTOR OF RECORD, OWNER AND THE ARCHITECT OR ENGINEER IN RESPONSIBLE CHARGE.

(i) AFTER AT LEAST 24 HOURS HAVE ELAPSED SINCE INSTALLATION, DIRECT PULL TENSION TEST OR TORQUE TEST AT LEAST 50% OF THE ANCHORS.

(ii) ACCEPTANCE CRITERIA:

- DIRECT TENSION TEST: THE ANCHOR SHOULD HAVE NO OBSERVABLE MOVEMENT AT THE TEST LOAD. A PRACTICAL WAY TO DETERMINE OBSERVABLE MOVEMENT IS THAT THE WASHER BECOMES LOOSE.
- TORQUE TEST: THE APPLICABLE TORQUE MUST BE ACHIEVED WITHIN THE FOLLOWING LIMITS: WEDGE TYPE : 1/2 TURN OF THE NUT

(iii) IF ANY ANCHOR FAILS, TEST ALL ANCHORS.

D. AVOID DAMAGING EXISTING STEEL REINFORCING IN CONCRETE SLAB WHEN INSTALLING CONCRETE EXPANSION ANCHORS.

E. PROVIDE FOR FULL THREAD ENGAGEMENT OF NUT & WASHER.

11. BOLTS THROUGH CONCRETE ON METAL DECK

A. BOLTS SHALL BE TORQUED BY 3/4 TURN OF THE NUTS AFTER THE SNUG TIGHT (THE SNUG-TIGHT CONDITION IS DEFINED AS THE TIGHTNESS REQUIRED TO BRING THE CONNECTED PLIES INTO FIRM CONTACT) CONDITION IS ACHIEVED, UNLESS OTHERWISE NOTED.

B. THROUGH BOLT HOLES SHALL BE 1/16" LARGER THAN BOLT SIZE

C. (HOLE SIZE = BOLT SIZE + 1/16) FOR CONCRETE.

D. THROUGH-BOLTS IN CONCRETE SHALL RECEIVE SPECIAL INSPECTION AND TESTING (THROUGH BOLTS WITH STEEL TO STEEL CONNECTION IN TENSION DO NOT REQUIRE TENSION TESTING) IN ACCORDANCE WITH REQUIREMENTS FOR POST-INSTALLED ANCHORS.

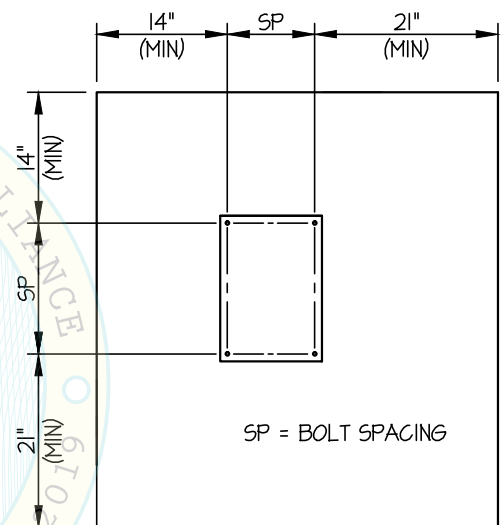

TYPICAL CONCRETE EDGE DETAIL
(SLAB ON GRADE ONLY)



CARESTREAM HEALTH, INC

COMPASS SYSTEM GENERATOR

DES. J. ROBERSON

JOB NO. 11-2104

DATE 10/1/21

SHEET

3

OF 6 SHEETS

SEISMIC SUPPORTS & ATTACHMENTS

CONCRETE SLAB

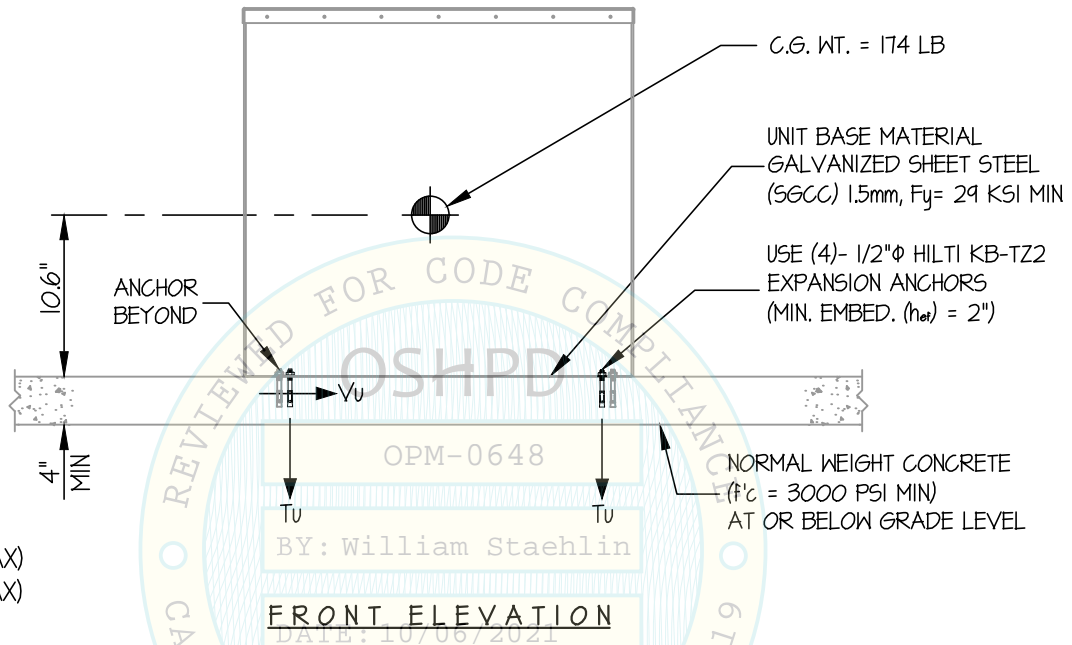

Tu = 162 LB/BOLT (MAX)
Vu = 147 LB/BOLT (MAX)
(VALUES INCLUDE Ω)

NOTES:

1. FORCES ARE DETERMINED PER 2019 CALIFORNIA BUILDING CODE AND ASCE 7-16. STRENGTH DESIGN IS USED. ($S_{Ds} = 2.30, a_p = 2.5, I_p = 1.5, R_p = 6.0, \Omega_o = 2.0, z/h = 0$)

HORIZONTAL FORCE (E_h) = 1.035 W_p

HORIZONTAL FORCE (E_{mh}) = 2.07 W_p (FOR CONCRETE ANCHORAGE)

VERTICAL FORCE (E_v) = 0.46 W_p

2. CENTER OF GRAVITY (C.G.) AND WEIGHT ARE THE GOVERNING PARAMETERS FOR DESIGN. THIS PREAPPROVAL ENCOMPASSES ALL WEIGHTS UP TO THE MAXIMUM WEIGHT SHOWN.
3. STRUCTURAL ENGINEER OF RECORD FOR THE BUILDING SHALL PROVIDE SUPPORT STRUCTURE DESIGNED TO SUPPORT WEIGHTS AND FORCES SHOWN IN COMBINATION WITH ALL OTHER LOADS THAT MAY BE PRESENT.
4. GENERATOR (UJT-2102-5) HAS OBTAINED SPECIAL SEISMIC CERTIFICATION REFER TO OSP-0703.
5. SEE GENERAL NOTES; SHEETS 1 AND 2



CARESTREAM HEALTH, INC

DES. **J. ROBERSON**

SHEET

4

COMPASS SYSTEM GENERATOR

JOB NO. **11-2104**

DATE **10/1/21**

OF **6** SHEETS

SEISMIC SUPPORTS & ATTACHMENTS

CONCRETE SLAB

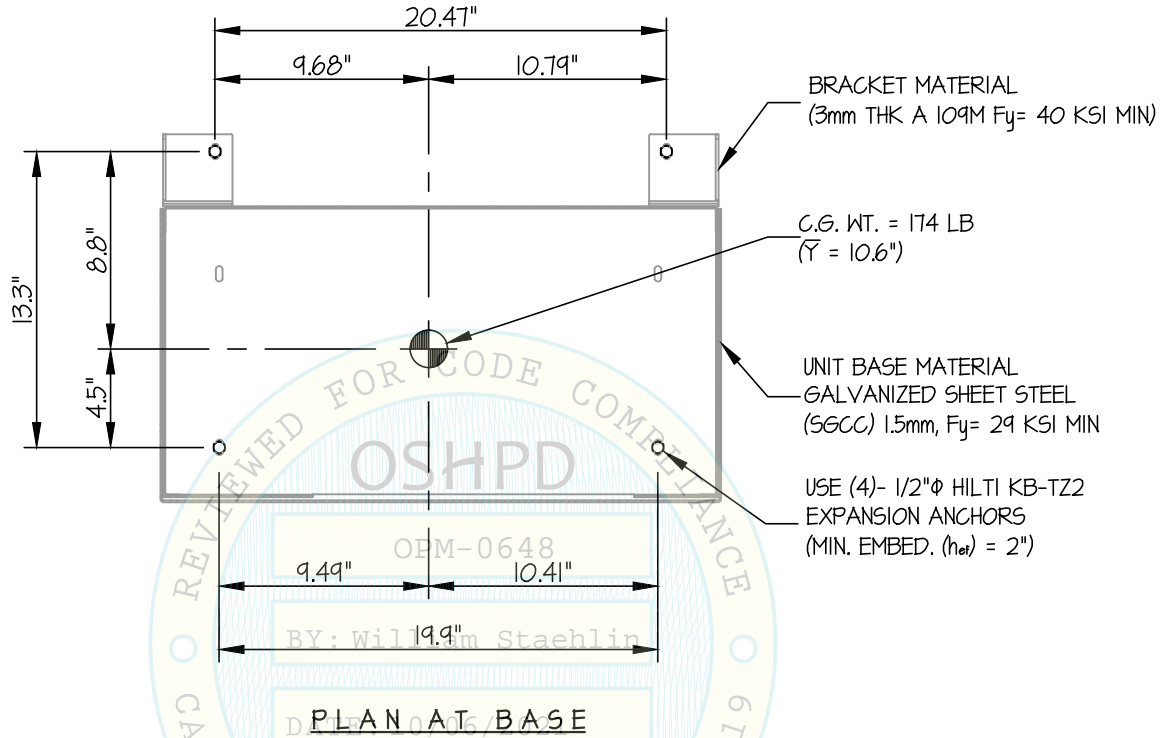

CARESTREAM HEALTH, INC

COMPASS SYSTEM GENERATOR

DES. J. ROBERSON

JOB NO. 11-2104

DATE 10/1/21

SHEET

5

OF 6 SHEETS

SEISMIC SUPPORTS & ATTACHMENTS

CONCRETE SLAB ON METAL DECK

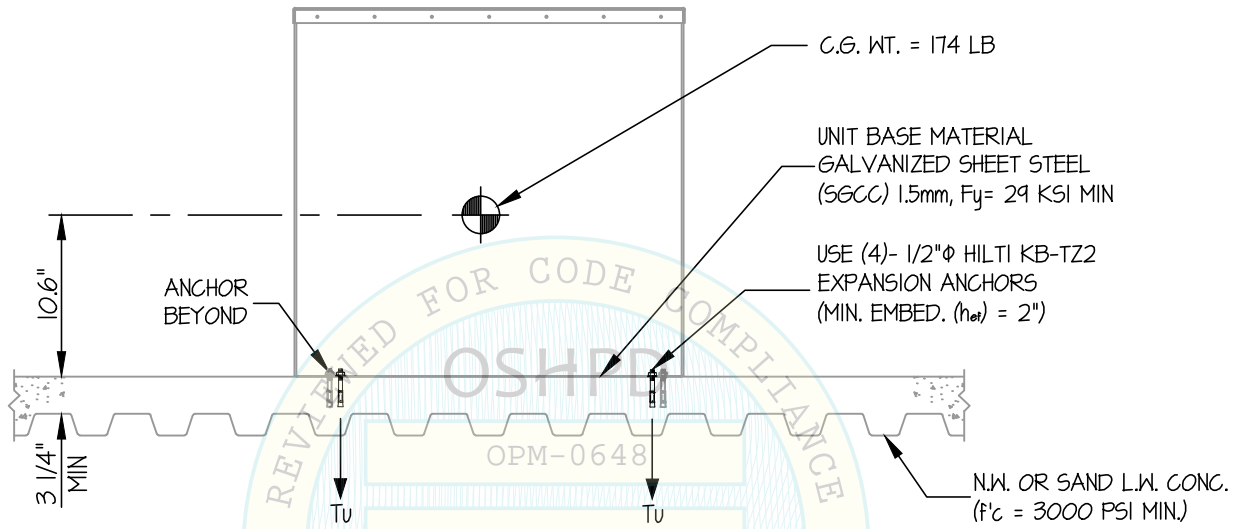

$T_u = 243 \text{ LB/BOLT (MAX)}$
 $V_u = 214 \text{ LB/BOLT (MAX)}$
 (VALUES DO NOT INCLUDE Ω)

FRONT ELEVATION

NOTES:

1. FORCES ARE DETERMINED PER 2019 CALIFORNIA BUILDING CODE AND ASCE 7-16 STRENGTH DESIGN IS USED. ($S_{Ds} = 2.00$ $\alpha_p = 2.5$, $I_p = 1.5$, $R_p = 6.0$, $\Omega_o = 2.0$, $z/h \leq 1$)

HORIZONTAL FORCE (E_h) = $1.50 W_p$

HORIZONTAL FORCE (E_{mh}) = $3.00 W_p$ (FOR CONCRETE ANCHORAGE)

VERTICAL FORCE (E_v) = $0.40 W_p$

2. CENTER OF GRAVITY (C.G.) AND WEIGHT ARE THE GOVERNING PARAMETERS FOR DESIGN. THIS PREAPPROVAL ENCOMPASSES ALL WEIGHTS UP TO THE MAXIMUM WEIGHT SHOWN.

3. STRUCTURAL ENGINEER OF RECORD FOR THE BUILDING SHALL PROVIDE SUPPORT STRUCTURE DESIGNED TO SUPPORT WEIGHTS AND FORCES SHOWN IN COMBINATION WITH ALL OTHER LOADS THAT MAY BE PRESENT.

4. PATIENT TABLE (UUT-2102-5) HAS OBTAINED SPECIAL SEISMIC CERTIFICATION REFER TO OSP-0703.

5. SEE GENERAL NOTES: SHEETS 1 AND 2

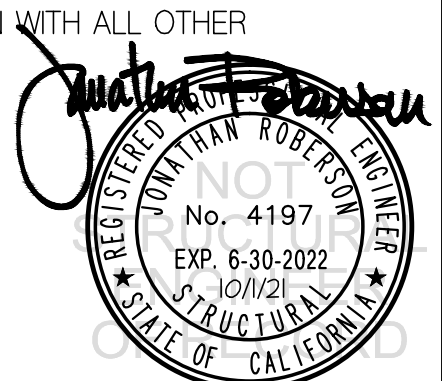

CARESTREAM HEALTH, INC

DES. J. ROBERSON

SHEET

6

COMPASS SYSTEM GENERATOR

JOB NO. 11-2104

DATE 10/1/21

OF 6 SHEETS

SEISMIC SUPPORTS & ATTACHMENTS

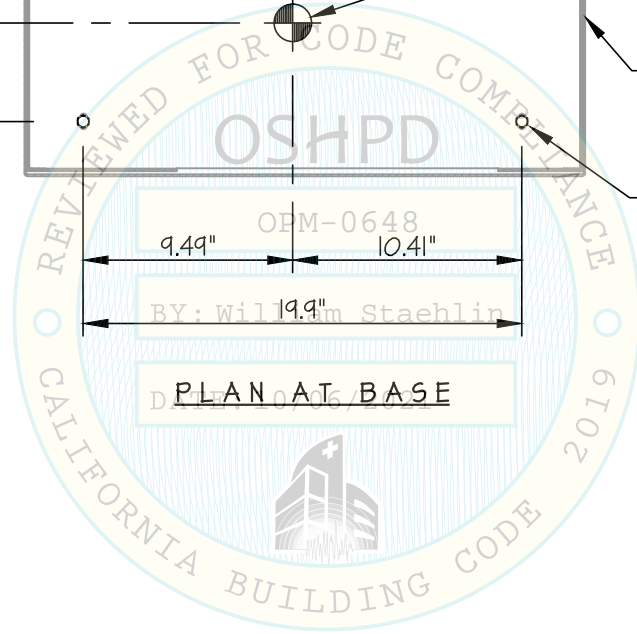
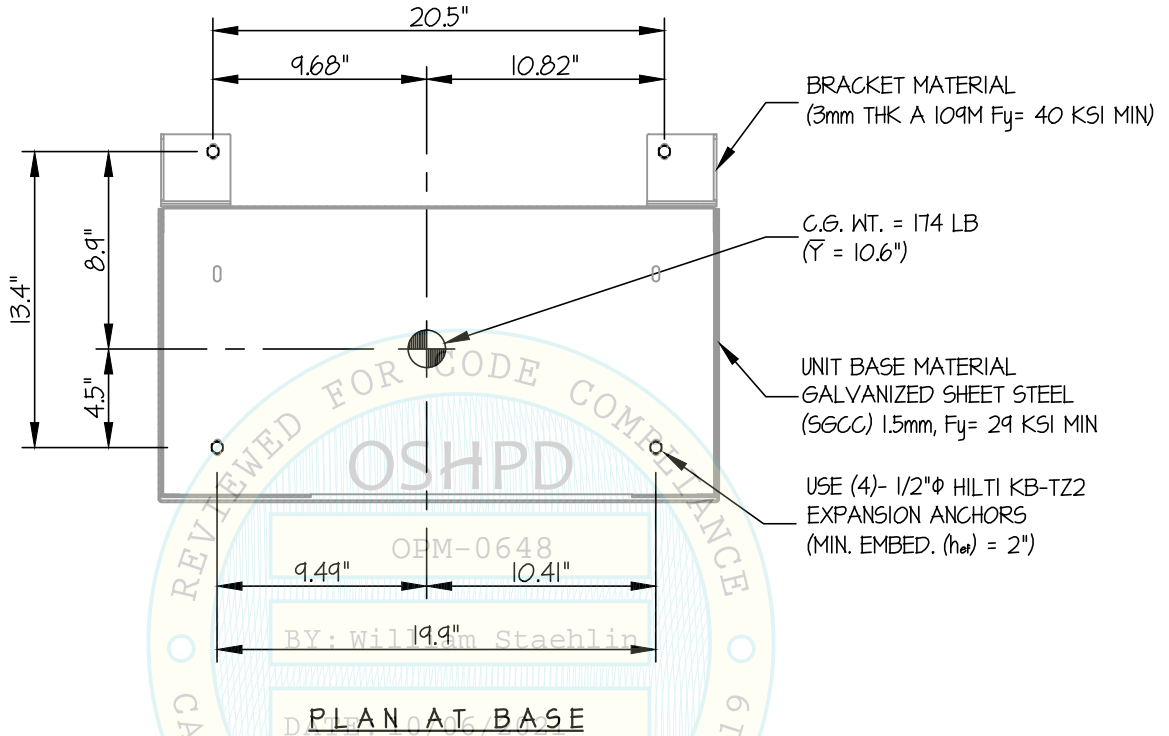

Jonathan Roberson
REGISTERED PROFESSIONAL ENGINEER
JONATHAN ROBERSON
No. 4197
EXP. 6-30-2022
10/1/21
STRUCTURAL
STATE OF CALIFORNIA