



DEPARTMENT OF HEALTH CARE ACCESS AND INFORMATION  
OFFICE OF STATEWIDE HOSPITAL PLANNING AND DEVELOPMENT

APPLICATION FOR HCAI PREAPPROVAL OF  
MANUFACTURER'S CERTIFICATION (OPM)

OFFICE USE ONLY

APPLICATION #: OPM-0768

HCAI Preapproval of Manufacturer's Certification (OPM)

Type:  New  Renewal/Update

Manufacturer Information

Manufacturer: MillerKnoll

Manufacturer's Technical Representative: Lillian Johnson

Mailing Address: 855 E. main Ave, Zeeland, MI 49464

Telephone: (920) 716-4378

Email: lillian\_johnson@hermanmiller.com

Product Information

Product Name: Action Office II (30 in)

Product Type: other mechanical or electrical components

Product Model Number: N/A

General Description: Workstation

Applicant Information

Applicant Company Name: EASE LLC.

Contact Person: Tiffany Tonn

Mailing Address: 1515 FAIRVIEW AVE, STE 205, MISSOULA, MT 59801

Telephone: (406) 541-3273

Email: tiffany@easeco.com

Title: Office Assistant

*"A healthier California where all receive equitable, affordable, and quality health care"*

STATE OF CALIFORNIA – HEALTH AND HUMAN SERVICES AGENCY





**DEPARTMENT OF HEALTH CARE ACCESS AND INFORMATION  
OFFICE OF STATEWIDE HOSPITAL PLANNING AND DEVELOPMENT**

**Registered Design Professional Preparing Engineering Recommendations**

Company Name: EASE LLC  
 Name: Jonathan Roberson California License Number: S4197  
 Mailing Address: 5877 Pine Ave., Suite 210, Chino Hills, CA 91709  
 Telephone: (951) 295-1892 Email: jon@EASECo.com

**Certification Method**

Testing in accordance with:  ICC-ES AC156  FM 1950  ASHRAE 171  FEMA 461  
 Other(s) (Please Specify): \_\_\_\_\_

\*Use of criteria other than those adopted by the California Building Standards Code, 2025 (CBSC 2025) for component supports and attachments are not permitted. For distribution system, interior partition wall, and suspended ceiling seismic bracings, test criteria other than those adopted in the CBSC 2025 may be used when approved by HCAI prior to testing.

Analysis  
 Experience Data  
 Combination of Testing, Analysis, and/or Experience Data (Please Specify): \_\_\_\_\_

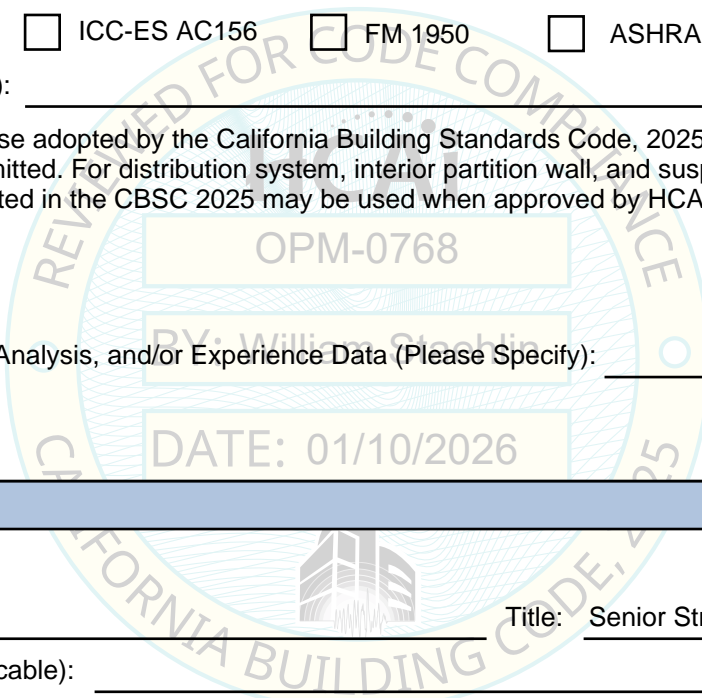

**HCAI Approval**

Date: 1/10/2026  
 Name: William Staehlin Title: Senior Structural Engineer  
 Condition of Approval (if applicable): \_\_\_\_\_

*"A healthier California where all receive equitable, affordable, and quality health care"*

**STATE OF CALIFORNIA – HEALTH AND HUMAN SERVICES AGENCY**





**EQUIPMENT ANCHORAGE  
& SEISMIC ENGINEERING**

5877 Pine Ave, Ste. 210  
Chino Hills, CA. 91709  
Phn: (909) 606-7622

The Department of Health Care Access and Information  
**PREAPPROVAL OF MANUFACTURER'S CERTIFICATION**  
**OPM-0768**

**THIS PREAPPROVAL CONFORMS TO THE 2025 CALIFORNIA BUILDING CODE**

MANUFACTURER: **MillerKnoll**  
EQUIPMENT NAME: **ACTION OFFICE SERIES II (30 in)**

Sheet: 1 of 10  
Date: 1/7/26

**GENERAL NOTES**

1. THIS HCAI PREAPPROVAL OF MANUFACTURER'S CERTIFICATION (OPM) IS BASED ON THE 2025 CBC. THE DEMANDS (DESIGN FORCES) FOR USE WITH THIS OPM SHALL BE BASED ON THE 2025 CBC
2. THIS DOCUMENT MAY ONLY BE USED WITH THE EXPRESS WRITTEN CONSENT OF THE MANUFACTURER LISTED ABOVE FOR THE SPECIFIC PROJECT SITE AND INSTALLATION LOCATION. THIS DOCUMENT IS INVALID WITHOUT SUCH CONSENT.
3. THIS PREAPPROVAL CONFORMS TO THE 2025 CALIFORNIA BUILDING CODE WHERE SDS IS NOT GREATER THAN 0.90, 1.60 & 2.50.
4. FORCES PER ASCE 7-22 SECTION 13.3.1, EQUATIONS 13.3-1, 13.3-2 & 13.3-3,  
WHERE  $S_{Ds}=2.50, I_p=1.5, C_{AR}=1.0, R_{po}=1.5, z/h=0, (R_u=1.0, H_f=1.0)$  AT CONCRETE SLAB AT OR BELOW GRADE. SEE FOLLOWING SHEETS FOR  $\Omega_{op}$   
WHERE  $S_{Ds}=0.90, I_p=1.5, C_{AR}=1.0, R_{po}=1.5, z/h=0, (R_u=1.0, H_f=1.0)$  AT CONCRETE SLAB ON METAL DECK AT OR BELOW GRADE.  
WHERE  $S_{Ds}=1.60, I_p=1.5, C_{AR}=1.0, R_{po}=1.5, z/h \leq 0.95, (R_u=1.3, H_f=3.375)$  AT CONCRETE SLAB ON METAL DECK.  
SEE FOLLOWING SHEETS FOR  $\Omega_{op}$
5. THIS PREAPPROVAL COVERS ONLY THE SUPPORTS AND ATTACHMENTS OF THE EQUIPMENT TO THE STRUCTURE.
6. ALL DESIGN FORCES SHOWN ON THE DRAWINGS ARE FACTORED LOADS THAT SHALL BE USED FOR STRENGTH DESIGN.
7. CONCRETE SLAB ON METAL DECK DETAIL VALID FOR DEMANDS SHOWN AT ANY ELEVATION IN THE BUILDING. (i.e.  $z/h \leq 0.95$ )
8. CONCRETE SLAB DETAIL VALID FOR DEMANDS SHOWN AT OR BELOW GRADE. (i.e.  $z/h = 0$ )
9. **RESPONSIBILITIES OF THE STRUCTURAL ENGINEER OF RECORD OF THE BUILDING**
  - A. PROVIDE SUPPORTING STRUCTURE TO SUPPORT WEIGHTS AND FORCES SHOWN IN ADDITION TO ALL OTHER LOADS.
  - B. VERIFY THAT THE INSTALLATION IS IN CONFORMANCE WITH THE 2025 CBC AND WITH THE DETAILS, MATERIAL AND GAGE OF THE UNIT WHERE ATTACHMENTS ARE MADE AGREE WITH THE INFORMATION SHOWN ON THE PREAPPROVAL DOCUMENTS.
  - C. VERIFY THAT PROJECT SPECIFIC SEISMIC PARAMETERS RESULT IN SEISMIC FORCES ( $E_h, E_v$ ) THAT DO NOT EXCEED THE VALUES IN THIS OPM.
  - D. VERIFY THAT THE CONCRETE SLAB TO WHICH THE EQUIPMENT IS ANCHORED MEETS THE REQUIREMENTS OF THE APPLICABLE ICC ESR REPORT AND THIS OPM.
  - E. VERIFY THAT THE ANCHORS ARE AN ADEQUATE DISTANCE FROM ANY SLAB EDGES OR OPENINGS (SEE TYPICAL DETAIL ON SHEET 2).
  - F. VERIFY THAT ALL NEW OR EXISTING ANCHORS ARE AN ADEQUATE DISTANCE FROM THE UNIT ATTACHMENTS AND CHECK FOR INTERACTION WHERE OTHER ANCHORS ARE WITHIN 18" OR  $6h_{ef}$  FROM THIS UNIT'S ANCHORS.



**MillerKnoll**

DES. **J. ROBERSON**

SHEET

**2**

JOB NO. **11-2331**

OF **10** SHEETS

## ACTION OFFICE SERIES II (30 in)

DATE **1/7/26**

### 10. EXPANSION ANCHORS:

- A. ATTACHMENT IS TO BE MADE WITH THE ANCHORS LISTED BELOW AND INSTALLED AS DESCRIBED IN THE CORRESPONDING ICC REPORT.

| Anchor Diameter | Concrete Type     | Min. f'c (psi) | Anchor Type                           | ICC Report No. | Min. Embed. | Min. Spacing | Min. Edge Dist. | Min. Conc. Thickness | Torque Test | Direct Tension Test |
|-----------------|-------------------|----------------|---------------------------------------|----------------|-------------|--------------|-----------------|----------------------|-------------|---------------------|
| 3/8"            | Sand Light Weight | 3000           | Hilti Kwik Bolt TZ2<br>(CARBON STEEL) | ESR-4266       | 2"          | 6.75"        | 12"             | See Detail "A"       | 40 FT-LB    | N/A                 |
| 1/2"            | Sand Light Weight | 3000           | Hilti Kwik Bolt TZ2<br>(CARBON STEEL) | ESR-4266       | 2"          | 8"           | 16"             | 3.25"                | 50 FT-LB    | 1190 lb             |
| 5/8"            | Normal Weight     | 3000           | Hilti Kwik Bolt TZ2<br>(CARBON STEEL) | ESR-4266       | 3.125"      | 12"          | 32"             | 6"                   | 40 FT-LB    | 4106 lb             |

- B. THIS PREAPPROVAL ALLOWS FOR UP TO A MAXIMUM OF 2 ADJACENT CONCRETE SLAB EDGES, 16" & 32" AWAY MINIMUM (i.e. - CORNER).  
SEE ADJACENT DETAIL FOR ADDITIONAL MINIMUM ALLOWABLE CONCRETE EDGE DISTANCES.

- C. TESTING AND SPECIAL INSPECTION OF EXPANSION ANCHORS SHALL BE PERFORMED BY AN APPROVED INDEPENDENT AGENCY EMPLOYED BY THE FACILITY OWNER PER CBC 1704A & 1910A.5 AND CAC 7-149. ALL REPORTS SHALL BE SENT TO THE INSPECTOR OF RECORD, OWNER AND THE ARCHITECT OR ENGINEER IN RESPONSIBLE CHARGE.

- (i) DIRECT PULL TENSION TEST OR TORQUE TEST AT LEAST 50% OF THE ANCHORS.

- (ii) ACCEPTANCE CRITERIA:

- DIRECT TENSION TEST: THE ANCHOR SHOULD HAVE NO OBSERVABLE MOVEMENT AT THE TEST LOAD. A PRACTICAL WAY TO DETERMINE OBSERVABLE MOVEMENT IS THAT THE WASHER BECOMES LOOSE.
- TORQUE TEST: THE APPLICABLE TORQUE MUST BE ACHIEVED WITHIN THE FOLLOWING LIMITS: WEDGE TYPE : 1/2 TURN OF THE NUT

- (iii) IF ANY ANCHOR FAILS, TEST ALL ANCHORS.

- D. AVOID DAMAGING EXISTING STEEL REINFORCING IN CONCRETE SLAB WHEN INSTALLING CONCRETE EXPANSION ANCHORS.

- E. PROVIDE FOR FULL THREAD ENGAGEMENT OF NUT & WASHER.

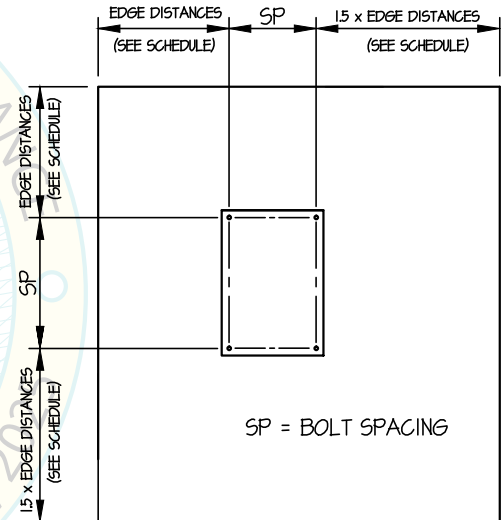

TYPICAL CONCRETE EDGE DETAIL  
(SLAB AT OR BELOW GRADE ONLY)

### 11. BOLTS THROUGH CONCRETE ON METAL DECK

- A. BOLTS SHALL BE TORQUED BY 3/4 TURN OF THE NUTS AFTER THE SNUG TIGHT (THE SNUG-TIGHT CONDITION IS DEFINED AS THE TIGHTNESS REQUIRED TO BRING THE CONNECTED PLIES INTO FIRM CONTACT) CONDITION IS ACHIEVED, UNLESS OTHERWISE NOTED.
- B. THROUGH BOLT HOLES SHALL BE 1/16" LARGER THAN BOLT SIZE (HOLE SIZE = BOLT SIZE + 1/16) FOR CONCRETE.
- C. THROUGH-BOLTS IN CONCRETE SHALL RECEIVE SPECIAL INSPECTION AND TESTING (THROUGH BOLTS WITH STEEL TO STEEL CONNECTION IN TENSION DO NOT REQUIRE TENSION TESTING) IN ACCORDANCE WITH REQUIREMENTS FOR POST-INSTALLED ANCHORS.



### MillerKnoll

DES. **J. ROBERSON**

SHEET

# 3

JOB NO. **11-2331**

DATE **1/7/26**

OF **10** SHEETS

## ACTION OFFICE SERIES II (30 in)

SEISMIC SUPPORTS & ATTACHMENTS

CONCRETE SLAB AT OR BELOW GRADE

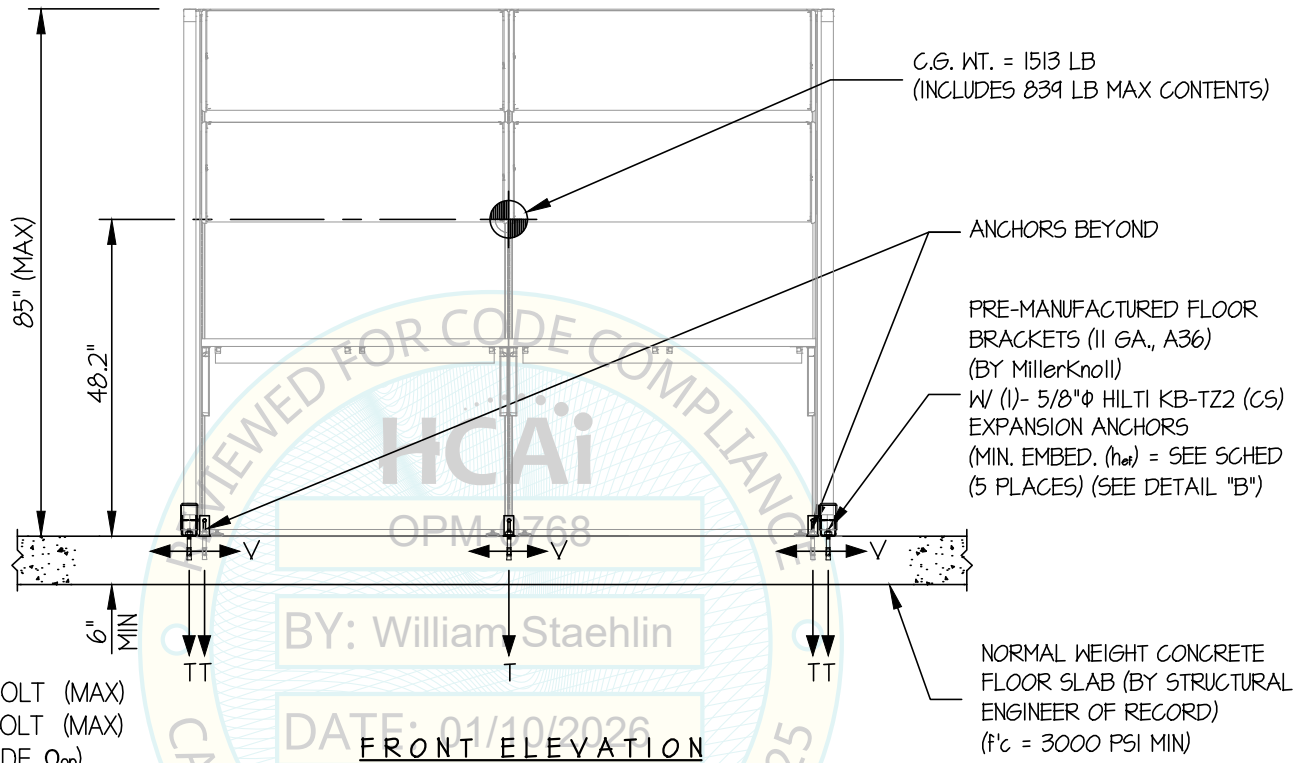

T<sub>u</sub> = 2810 LB/BOLT (MAX)  
V<sub>u</sub> = 1035 LB/BOLT (MAX)  
(VALUES INCLUDE Ω<sub>op</sub>)

### NOTES:

- FORCES ARE DETERMINED PER 2025 CALIFORNIA BUILDING CODE AND ASCE 7-22. STRENGTH DESIGN IS USED. (EXAMPLE: S<sub>ds</sub>=2.50, I<sub>p</sub>=1.5, C<sub>AR</sub>=1.0, R<sub>po</sub>=1.5, Ω<sub>op</sub>=2.0, R<sub>l</sub>=1.0, H<sub>f</sub>=1.0, z/h=0)
 

|                                     |   |       |   |
|-------------------------------------|---|-------|---|
| HORIZONTAL FORCE (E <sub>h</sub> )  | = | 1.125 | W <sub>p</sub>                          |
| HORIZONTAL FORCE (E <sub>mh</sub> ) | = | 2.25  | W <sub>p</sub> (FOR CONCRETE ANCHORAGE) |
| VERTICAL FORCE (E <sub>v</sub> )    | = | 0.50  | W <sub>p</sub>                          |
- THIS PREAPPROVAL ENCOMPASSES WEIGHTS AND VERTICAL C.G. POSITIONS NOT EXCEEDING VALUES SHOWN.
- THIS PREAPPROVAL WAS PREPARED WITHOUT KNOWLEDGE OF ANY SITE CONDITION. COMPATIBILITY FOR USE WITH A SITE SHALL BE EVALUATED BY THE STRUCTURAL ENGINEER OF RECORD OF THE INSTALLATION (SEOR). USE REQUIRES APPROVAL BY THE SEOR.
- STRUCTURAL ENGINEER OF RECORD FOR THE INSTALLATION SHALL VERIFY ALL CONDITIONS, EVALUATE INTERACTION WITH ADJACENT EQUIPMENT AND ANCHORS, AND PROVIDE SUPPORT STRUCTURE DESIGNED TO SUPPORT WEIGHTS AND FORCES SHOWN IN COMBINATION WITH ALL OTHER LOADS THAT MAY BE PRESENT.
- SEE GENERAL NOTES: SHEETS 1 AND 2



### MillerKnoll

DES. **J. ROBERSON**

SHEET

# 4

JOB NO. **11-2331**

DATE **1/7/26**

OF **10** SHEETS

## ACTION OFFICE SERIES II (30 in)

SEISMIC SUPPORTS & ATTACHMENTS

CONCRETE SLAB AT OR BELOW GRADE

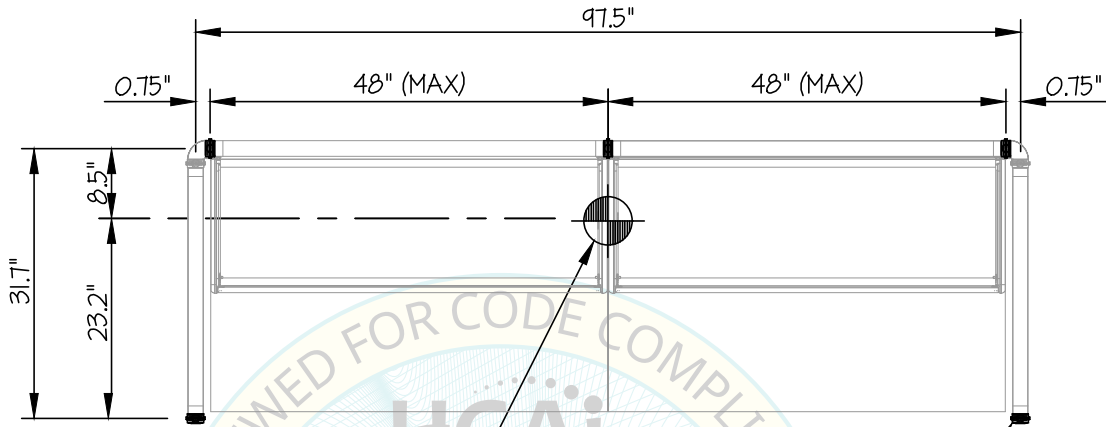

C.G. WT. = 1513 LB  
(INCLUDES 834 LB MAX CONTENTS)  
( $\bar{Y}$  = 48.2")

PLAN VIEW

BY: William Staehlin

DATE: 01/10/2026

PRE-MANUFACTURED FLOOR  
BRACKETS (11 GA., A36)  
(BY MillerKnoll)  
W/ (1)- 5/8"  $\phi$  HILTI KB-TZ2 (CS)  
EXPANSION ANCHORS  
(MIN. EMBED. ( $h_{ef}$ ) = 3.125")  
(5 PLACES) (SEE DETAIL "B")

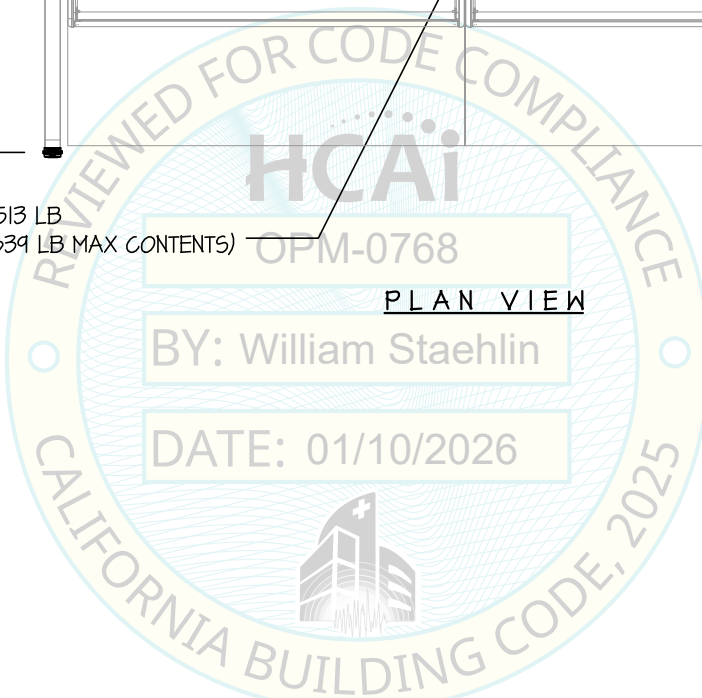

**MillerKnoll**

**ACTION OFFICE SERIES II (30 in)**

DES. **J. ROBERSON**

JOB NO. **11-2331**

DATE **1/7/26**

SHEET

**5**

OF **10** SHEETS

SEISMIC SUPPORTS & ATTACHMENTS

$S_{Ds} \leq 0.90$

CONCRETE SLAB ON METAL DECK AT GRADE OR BELOW

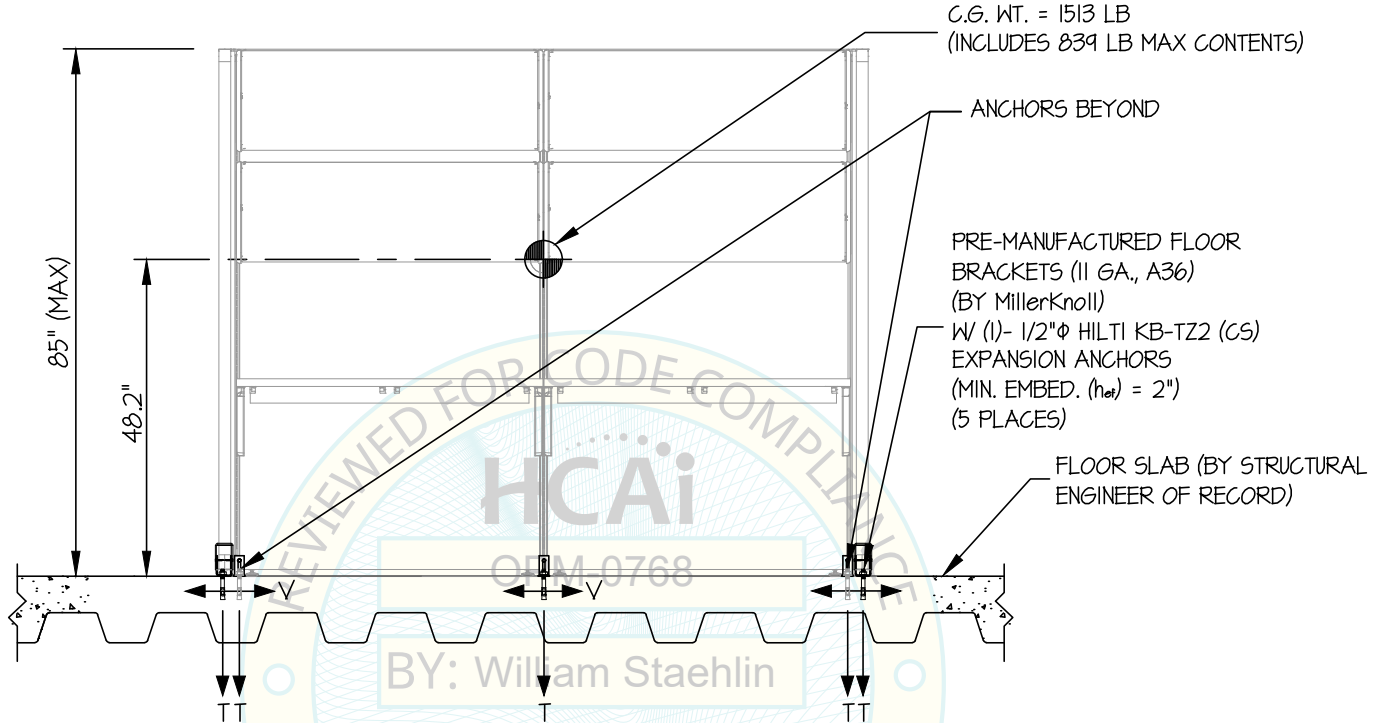

$T_U = 800 \text{ LB/BOLT (MAX)}$   
 $V_U = 373 \text{ LB/BOLT (MAX)}$   
(VALUES INCLUDE  $\Omega_{op}$ )

**NOTES:**

- FORCES ARE DETERMINED PER 2025 CALIFORNIA BUILDING CODE AND ASCE 7-22. STRENGTH DESIGN IS USED. (EXAMPLE:  $S_{Ds}=0.90$ ,  $I_p=15$ ,  $CAR=1.0$ ,  $R_{po}=1.5$ ,  $\Omega_{op}=2.0$ ,  $R_U=1.0$ ,  $H_f=1.0$ ,  $z/h=0$ )  
 HORIZONTAL FORCE ( $E_h$ ) =  $0.405 W_p$   
 HORIZONTAL FORCE ( $E_{mh}$ ) =  $0.81 W_p$  (FOR CONCRETE ANCHORAGE)  
 VERTICAL FORCE ( $E_v$ ) =  $0.18 W_p$
- THIS PREAPPROVAL ENCOMPASSES WEIGHTS AND VERTICAL C.G. POSITIONS NOT EXCEEDING VALUES SHOWN.
- THIS PREAPPROVAL WAS PREPARED WITHOUT KNOWLEDGE OF ANY SITE CONDITION. COMPATIBILITY FOR USE WITH A SITE SHALL BE EVALUATED BY THE STRUCTURAL ENGINEER OF RECORD OF THE INSTALLATION (SEOR). USE REQUIRES APPROVAL BY THE SEOR.
- STRUCTURAL ENGINEER OF RECORD FOR THE INSTALLATION SHALL VERIFY ALL CONDITIONS, EVALUATE INTERACTION WITH ADJACENT EQUIPMENT AND ANCHORS, AND PROVIDE SUPPORT STRUCTURE DESIGNED TO SUPPORT WEIGHTS AND FORCES SHOWN IN COMBINATION WITH ALL OTHER LOADS THAT MAY BE PRESENT.
- SEE GENERAL NOTES: SHEETS 1 AND 2

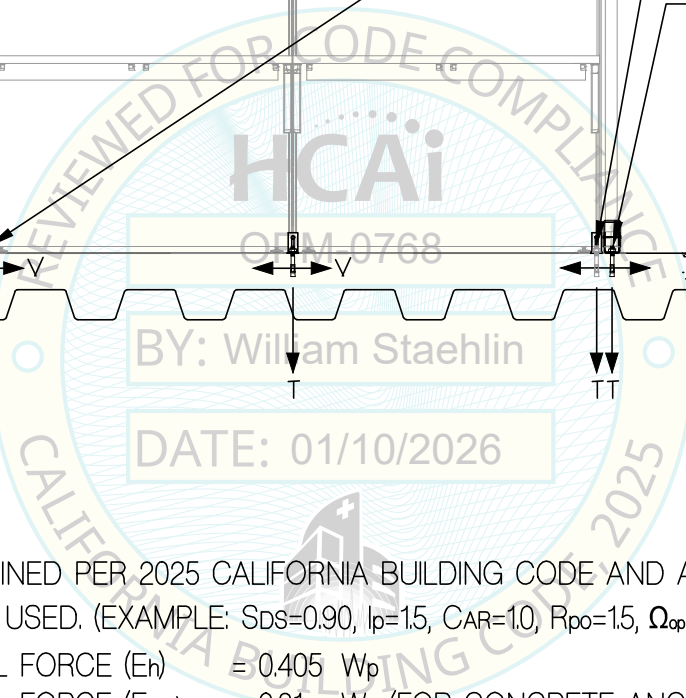

### MillerKnoll

DES. **J. ROBERSON**

SHEET

# 6

JOB NO. **11-2331**

DATE **1/7/26**

OF **10** SHEETS

## ACTION OFFICE SERIES II (30 in)

SEISMIC SUPPORTS & ATTACHMENTS

$S_Ds \leq 0.90$

CONCRETE SLAB ON METAL DECK AT GRADE OR BELOW

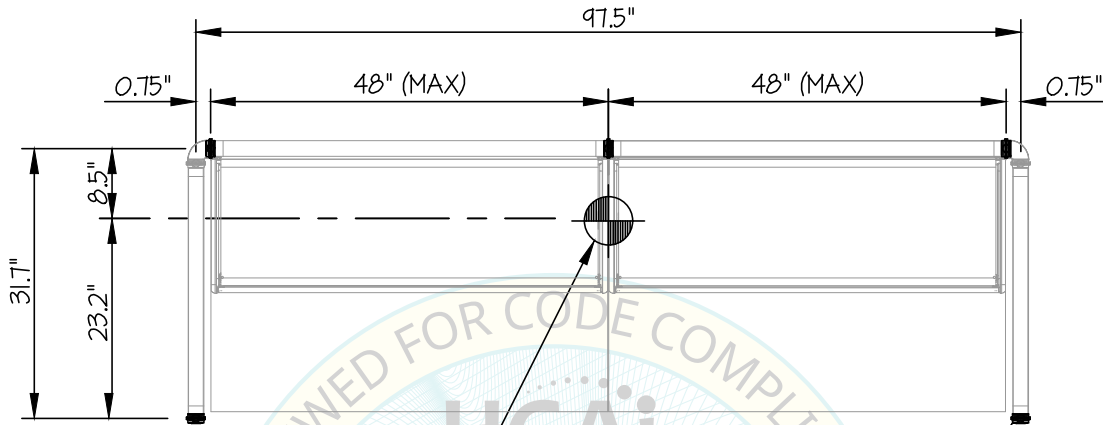

C.G. WT. = 1513 LB  
(INCLUDES 839 LB MAX CONTENTS)  
( $\bar{Y}$  = 48.2")

OPM-0768

PLAN VIEW

BY: William Staehlin

DATE: 01/10/2026

PRE-MANUFACTURED FLOOR  
BRACKETS (II GA., A36)  
(BY MillerKnoll)  
W/ (1)- 1/2"  $\Phi$  HILTI KB-TZ2 (C5)  
EXPANSION ANCHORS  
(MIN. EMBED. ( $h_{ef}$ ) = 2")  
(5 PLACES)



## MillerKnoll

DES. **J. ROBERSON**

SHEET

**7**

JOB NO. **11-2331**

DATE **1/7/26**

OF **10** SHEETS

### ACTION OFFICE SERIES II (30 in)

SEISMIC SUPPORTS & ATTACHMENTS

CONCRETE SLAB ON METAL DECK

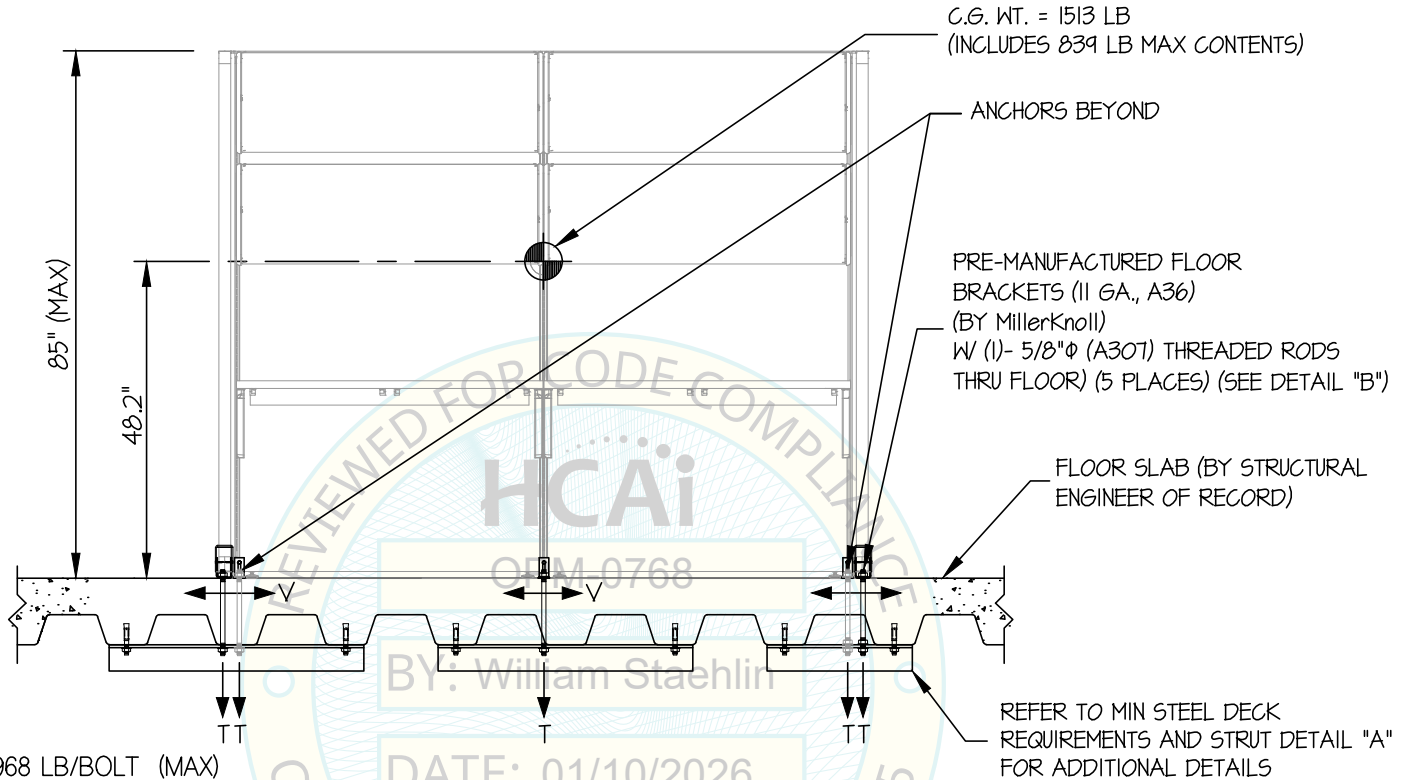

$T_u = 1968 \text{ LB/BOLT (MAX)}$   
 $V_u = 764 \text{ LB/BOLT (MAX)}$   
 (VALUES DO NOT INCLUDE  $\Omega_{op}$ )

NOTES:

- FORCES ARE DETERMINED PER 2025 CALIFORNIA BUILDING CODE AND ASCE 7-22. STRENGTH DESIGN IS USED. (EXAMPLE:  $S_{ds}=1.60$ ,  $I_p=1.5$ ,  $CAR=1.0$ ,  $R_{po}=1.5$ ,  $\Omega_{op}=2.0$ ,  $R_{\mu}=1.3$ ,  $H_f=3.375$ ,  $z/h \leq 0.95$ )  
 $\text{HORIZONTAL FORCE (E}_h) = 1.66 W_p$   
 $\text{HORIZONTAL FORCE (E}_{mh}) = 3.32 W_p \text{ (FOR CONCRETE ANCHORAGE)}$   
 $\text{VERTICAL FORCE (E}_v) = 0.32 W_p$
- THIS PREAPPROVAL ENCOMPASSES WEIGHTS AND VERTICAL C.G. POSITIONS NOT EXCEEDING VALUES SHOWN.
- THIS PREAPPROVAL WAS PREPARED WITHOUT KNOWLEDGE OF ANY SITE CONDITION. COMPATIBILITY FOR USE WITH A SITE SHALL BE EVALUATED BY THE STRUCTURAL ENGINEER OF RECORD OF THE INSTALLATION (SEOR). USE REQUIRES APPROVAL BY THE SEOR.
- STRUCTURAL ENGINEER OF RECORD FOR THE INSTALLATION SHALL VERIFY ALL CONDITIONS, EVALUATE INTERACTION WITH ADJACENT EQUIPMENT AND ANCHORS, AND PROVIDE SUPPORT STRUCTURE DESIGNED TO SUPPORT WEIGHTS AND FORCES SHOWN IN COMBINATION WITH ALL OTHER LOADS THAT MAY BE PRESENT.
- SEE GENERAL NOTES; SHEETS 1 AND 2



### MillerKnoll

DES. **J. ROBERSON**

SHEET

# 8

JOB NO. **11-2331**

DATE **1/7/26**

OF **10** SHEETS

## ACTION OFFICE SERIES II (30 in)

SEISMIC SUPPORTS & ATTACHMENTS

CONCRETE SLAB ON METAL DECK

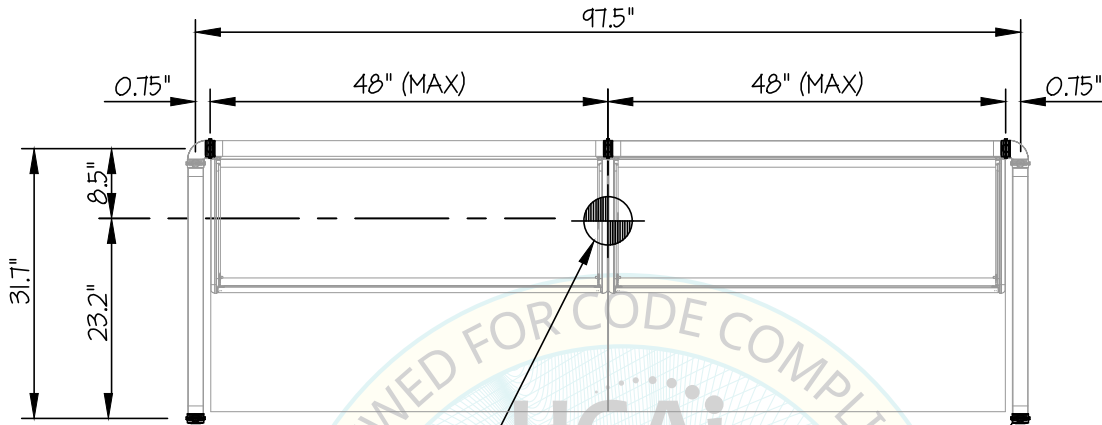

C.G. WT. = 1513 LB  
(INCLUDES 839 LB MAX CONTENTS)  
( $\bar{Y}$  = 48.2")

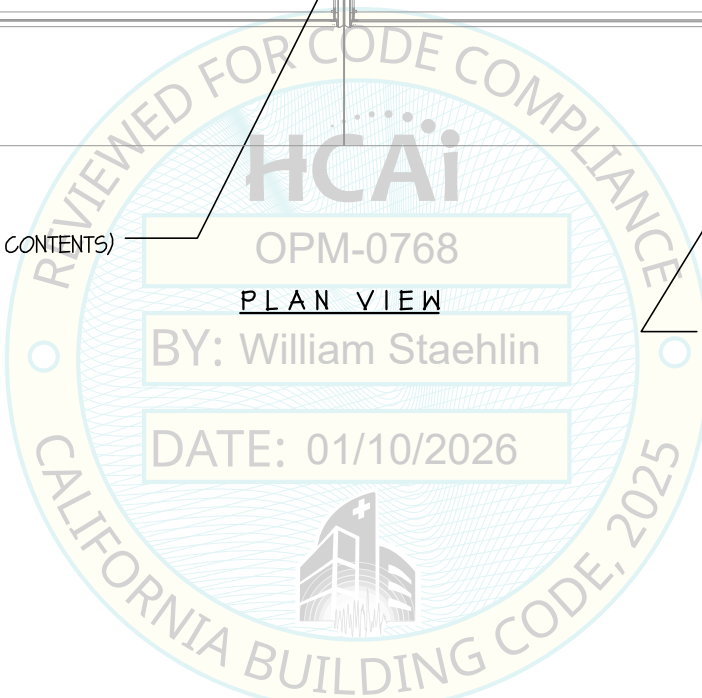

PRE-MANUFACTURED FLOOR BRACKETS (11 GA., A36) (BY MillerKnoll) W/ (1)- 5/8"Ø (A307) THREADED RODS THRU FLOOR) (5 PLACES) (SEE DETAIL "B")

*Jonathan Roberson*  
REGISTERED PROFESSIONAL ENGINEER  
JONATHAN ROBERSON  
No. 4197  
EXP. 6-30-2026  
1/1/26  
STRUCTURAL  
STATE OF CALIFORNIA



## MillerKnoll

DES. **J. ROBERSON**

SHEET

# 10

JOB NO. **11-2331**

DATE **1/7/26**

OF **10** SHEETS

### ACTION OFFICE SERIES II (30 in)

SEISMIC SUPPORTS & ATTACHMENTS

BRACKET DETAIL

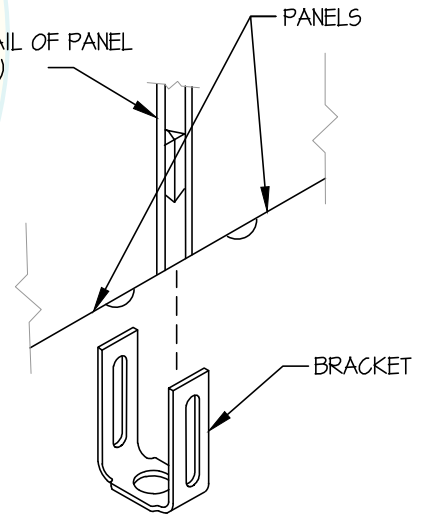
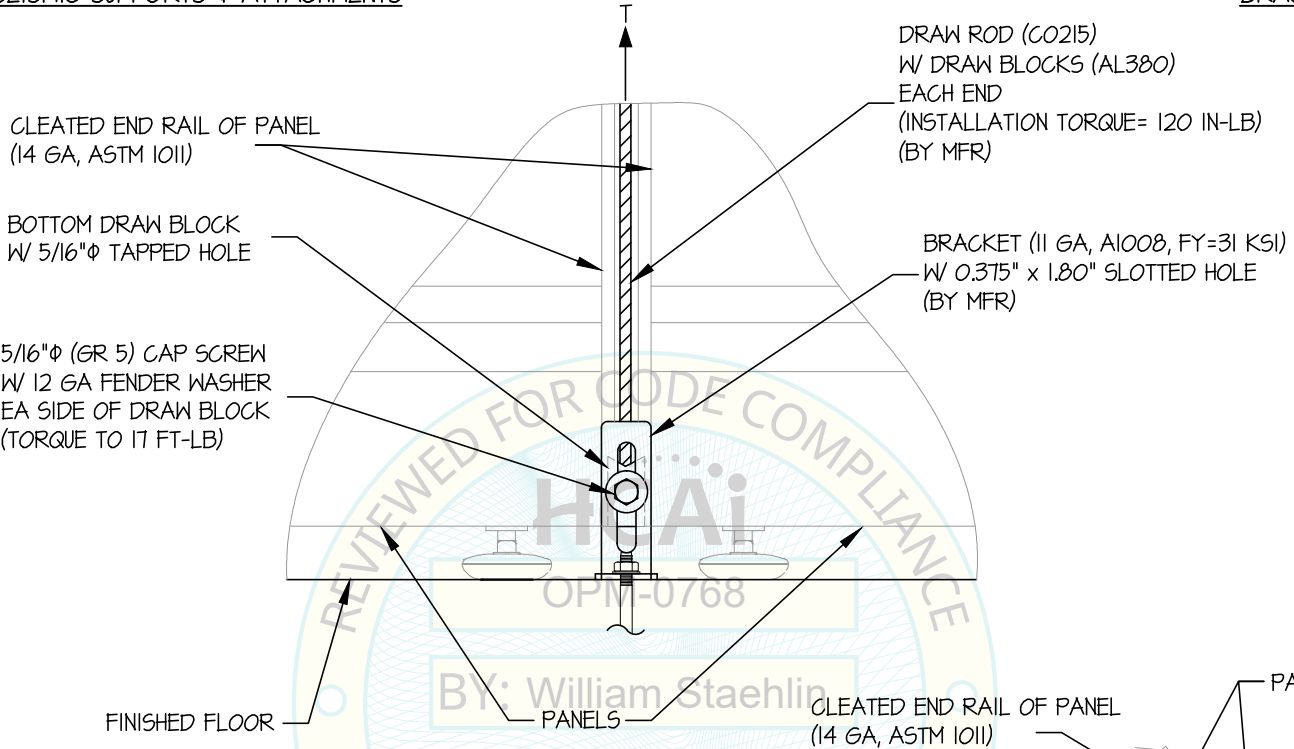

ISOMETRIC

BRACKET DETAIL (B)

