



**DEPARTMENT OF HEALTH CARE ACCESS AND INFORMATION
FACILITIES DEVELOPMENT DIVISION**

**APPLICATION FOR HCAI SPECIAL SEISMIC
CERTIFICATION PREAPPROVAL (OSP)**

OFFICE USE ONLY

APPLICATION #: OSP-0685

HCAI Special Seismic Certification Preapproval (OSP)

Type: New Renewal

Manufacturer Information

Manufacturer: Rolls-Royce Solutions America, Inc.

Manufacturer's Technical Representative: Ben Stratton

Mailing Address: 100 Power Drive, Mankato, MN 56001

Telephone: (507) 625-7973

Email: Ben.Stratton@ps.rolls-royce.com

Product Information

Product Name: Emergency and Standby Power Systems

Product Type: Generators

Product Model Number: MTU8V0110GS150, MTU4R0120DS125, & MTU6R0120DS200

General Description: Gas Powered Electrical Generator

Mounting Description: Rigid and Isolated, Floor Mounted

Tested Seismic Enhancements: Seismic enhancements made to the test units and/or modifications required to address anomalies during the tests shall be incorporated into the production units.

Applicant Information

Applicant Company Name: VMC Group

Contact Person: John Giuliano

Mailing Address: Main Street, Bloomingdale, NJ 07403

Telephone: (973) 838-1780

Email: john.giuliano@thvmcgroup.com

Title: President





DEPARTMENT OF HEALTH CARE ACCESS AND INFORMATION
FACILITIES DEVELOPMENT DIVISION

California Licensed Structural Engineer Responsible for the Engineering and Test Report(s)

Company Name: THE VMC GROUP
Name: Kenneth Tarlow California License Number: S2851
Mailing Address: 980 9th Street, 16th Floor, Sacramento, CA 95814
Telephone: (832) 627-2214 Email: ken.tarlow@thevmcgroup.com

Certification Method

GR-63-Core ICC-ES AC156 IEEE 344 IEEE 693 NEBS 3
 Other (Please Specify):

Testing Laboratory

Company Name: DYNAMIC CERTIFICATION LABORATORY (DCL)
Contact Person: Kelly Laplace
Mailing Address: 1315 Greg St., Ste 109, Sparks NV 89431
Telephone: (775) 358-5085 Email: kelly@shaketest.com

Company Name: UNIVERSITY OF CALIFORNIA, BERKELEY (PEER)
Contact Person: Amarnath Kasalanati
Mailing Address: 1301 S. 46th Street, Building 420, Richmond CA 94804
Telephone: (510) 665-3594 Email: amarnath1@berkeley.edu

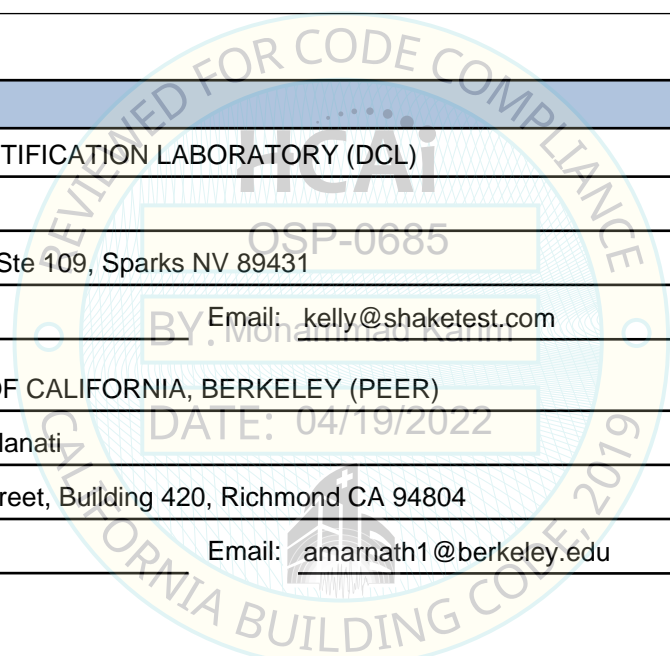



**DEPARTMENT OF HEALTH CARE ACCESS AND INFORMATION
FACILITIES DEVELOPMENT DIVISION**

Seismic Parameters

Design Basis of Equipment or Components (F_p/W_p) =	Rigid: 1.13 @z/h=0; 1.44 @z/h=1; Isolated: 1.88 @z/h=0; 4.5 @z/h = 1
SDS (Design spectral response acceleration at short period, g) =	2.5 @ z/h=0 ; 2.0 @ z/h=1.0
a_p (Amplification factor) =	Rigid: 1.0 ; Isolated: 2.5
R_p (Response modification factor) =	Rigid: 2.5 ; Isolated: 2.0
Ω_0 (System overstrength factor) =	2.0
I_p (Importance factor) =	1.5
z/h (Height ratio factor) =	1 and 0
Natural frequencies (Hz) =	See Attachment
Overall dimensions and weight =	See Attachment

HCAI Approval (For Office Use Only) - Approval Expires on 04/19/2028

Date:	4/19/2022	OSP-0685	
Name:	Mohammad Karim	BY: Mohammad Karim	Title: Supervisor, Health Facilities
Special Seismic Certification Valid Up to: SDS (g) =	See Above	z/h =	See Above
Condition of Approval (if applicable):	DATE: 04/19/2022		

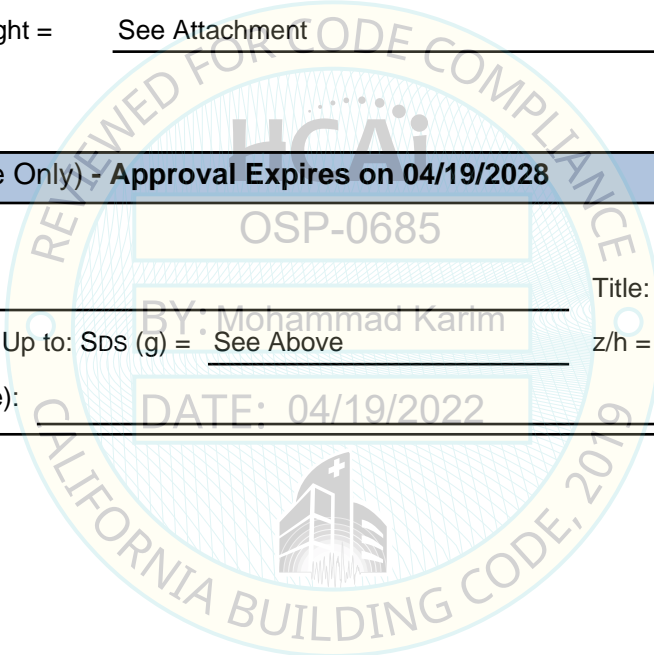

Table 1 - Certified Products - Gas Gensets - Off Tank

Model ¹	Max Rating [kW]	EPA Rating	Configuration	Max Package Dimensions [in]			Max Weight ³ [lb]	Mounting Configuration	UUT
				Length	Width	Height			
mtu 8V0110GS150	150	EPA 1048 and 60 part JJJJ compliant	Open ²	95	46	64	4,200	Rigid	Extrapolated
			Enclosed	132	48	79	4,550	Rigid	UUT-09
			Enclosed	120	51	88	5,400	Rigid	Interpolated

Notes:

1. MTU8V0110GS150 construction is similar to OM line but using Gaseous engine.
2. Open unit is a depopulated form of the enclosed unit.
3. Weight includes enclosure where applicable.

Table 2 - Certified Products - Diesel Gensets - On Tank

Model	Max Rating [kW]	EPA Rating	Configuration	Max Package Dimensions ¹ [in]			Max Weight ³ [lb]	Mounting Configuration	UUT
				Length	Width	Height			
mtu 4R0120DS125	125	Tier 3	Enclosed	180	48	130	12,020	Rigid	UUT-05
mtu 6R0120DS200	200	Tier 3	Enclosed	270	48	130	18,320	Isolated	UUT-06A

Notes:

1. Length and height dimensions include tank.
2. Weight includes enclosure where applicable.

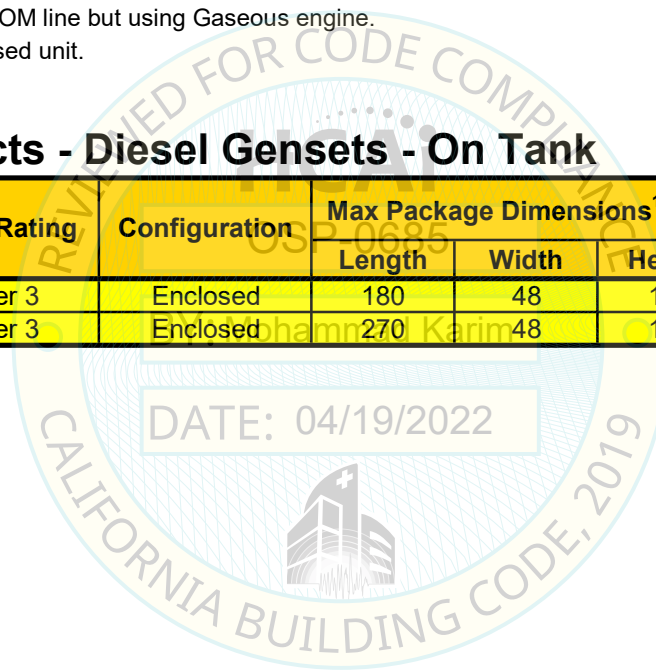

Table 3a - Certified Enclosures

Part Number	Type	Material	Max Dimensions [in]			Max Weight [lb]	Manufacturer	Mounting	UUT
			Length	Width	Height				
XSG25300.00461	150kW GS	Aluminum	100	51	80	337	Rolls-Royce Solutions America Inc.	Rigid / Isolated	Extrapolated
XSG25300.00461	150kW GS		100	51	80	337		Rigid	UUT-09
XSG21300.00006	80-125kW		100	51	80	337		Rigid / Isolated	Interpolated
XSG21300.00014	150-200 kW		112	51	87	450		Rigid / Isolated	Interpolated
XSG21300.00014	200kW		112	51	87	450		Isolated	UUT-06A, UUT-06B
XSG21300.00008	80-125kW	Carbon Steel	100	51	80	725		Rigid / Isolated	Extrapolated
XSG21300.00008	125kW		100	51	80	725		Rigid	UUT-05
XSG25300.00459	150 kW		100	51	87	725		Rigid / Isolated	Interpolated
XSG25300.00459	150 kW		100	51	87	725		Rigid / Isolated	UUT-10A, UUT-10B

Table 3b - Certified Enclosure Scoops

Part Number	Type	Material	Max Dimensions [in]			Max Weight [lb]	Manufacturer	Mounting	UUT
			Length	Width	Height				
XSG21300.00038	80-125kW Scoop	Aluminum	20	51	80	71	Rolls-Royce Solutions America Inc.	Rigid / Isolated	Extrapolated
XSG25300.00466	150kW GS Scoop		33	51	80	88		Rigid / Isolated	Extrapolated
XSG25300.00466	150kW GS Scoop		33	51	80	88		Rigid	UUT-09
XSG21300.00042	150-200kW Scoop		33	51	87	108		Rigid / Isolated	Interpolated
XSG21300.00042	200kW Scoop		33	51	87	108		Isolated	UUT-06A, UUT-06B
XSG21300.00039	80-125kW Scoop	Carbon Steel	20	51	80	171		Rigid / Isolated	Extrapolated
XSG21300.00039	125kW Scoop		20	51	80	171		Rigid	UUT-05
XSG25300.00465	150kW Scoop		33	51	80	210		Rigid / Isolated	Interpolated
XSG25300.00465	150kW Scoop		33	51	80	210		Rigid / Isolated	UUT-10A, UUT-10B

Table 4a - Certified Subcomponents - Gas And Diesel Gensets

Component [MFR]	Part Number	Notes	Weight [lb]	UUT
Alternators (Marathon)	360 Frame	80-125 kW	929	UUT-05
	430 Frame	85-200 kW, 150kW	2,365	UUT-06A, UUT-06B, UUT-09
Silencer (Miratech)	SUA106938	3" Space Saver Model, 12" Dia. CPJS-04X	44	UUT-05
	SUA101740	3"Space Saver 14" Dia. CPJS-04X	50	UUT-09
	SUA106939	3 1/2" Space Saver Model, 14" Dia. CPJS-05X	65	UUT-06A, UUT-06B
Air Filter (Donaldson)	XG2112100001	80-200 kW, 125kW	4	UUT-05, UUT-06A, UUT-06B
	XG2512100002	150 kW	4	UUT-09
Controller (Rolls-Royce Solutions America Inc.)	MGC-1500 Series	Each controller is a depopulated version of the controller with a higher number. The boxes of the 2000 and 3000 series are the same. The 1500 series box is smaller. All boxes are carbon steel.	55	UUT-05
	MGC-2000 Series		88	Interpolated
	MGC-3000 Series		90	UUT-06A, UUT-06B, UUT-09
Jacket Water Heaters (Kim Hotstart)	XSG21300.00031	1500 W	13	UUT-05
	XSG21300.00032	1800 W	13	UUT-06A, UUT-06B
	XSG25300.00469	1800 W	14	Interpolated
	XSG25300.00468	2000 W	14	UUT-09
Breakers (Square-D)	H Frame	150Amp Max Rating	5	Extrapolated
	J Frame	250 Amp Max Rating	7	UUT-05, UUT-09
	LA Frame	400 Amp Max Rating	24	Interpolated
	LD Frame	600 Amp Max Rating	24	UUT-05, UUT-09
	M Frame	800 Amp Max Rating	31	Interpolated
	P Frame	1200 Amp Max Rating	31	UUT-06A, UUT-06B, UUT-09
Distribution Panel (Rolls-Royce Solutions America Inc.)	XSG21300.00119	100A UL CSA	9	UUT-05, UUT-09
Battery (Exide)	SUA120299	12V	56	UUT-05, UUT-06A, UUT-06B, UUT-09
Battery Charger (SENS)	XG3042500013	12V 10A	6	Extrapolated
	XSG30340.00092	12/24V 6AMP	14	UUT-05
	SUA85257	6 A	14	Interpolated
	SUA87358	6 A	14	Interpolated
	SUA85204	10 A	25	Interpolated
	SUA86468	10 A	28	Interpolated
	SUA83187	10 A	28	Interpolated
XSG21360.00001 / SUA89983	10 A	28	UUT-06A, UUT-06B	
Battery Chargers (Marinco)	XG3130100003	12V 6A	4	UUT-09

Notes:

- Bolding** indicates tested configuration.

Table 4a - Certified Subcomponents - Gas And Diesel Gensets (Cont.)

Component [MFR]	Part Number	Notes	Weight [lb]	UUT
Lighting Kit (Rolls-Royce Solutions America Inc.)	XSD03300.00003	Lighting Kit (AC/DC)	10	UUT-05, UUT-06A, UUT-06B, UUT-09
Space Heater (King)	XG3006100004	1500 kW	12	UUT-09
Battery Warming Plate (Zero Start)	SUA33218	200 W	1	UUT-09
Louver (Rolls-Royce Solutions America Inc.)	XSG21300.00035	Motorized	89	UUT-09
Louver (Vent Products)	XG2530100105	Gravity	13	UUT-09

Table 4b - Certified Subcomponents - Gas Gensets Only

Component [MFR]	Part Number	Notes	Weight [lb]	UUT
Engine (PSI)	XG2534200005	8.8L	1,088	UUT-09
Radiator (PSI)	XG2541100021	150 kW	360	UUT-09





UNIT UNDER TEST (UUT) Summary Sheet

UUT-05

PEER STI 2015-17; UUT-5

Model Line	Model Number	Manufacturer
OM924	<i>mtu</i> 4R0120DS125	Rolls-Royce Solutions America Inc.

Product Construction Summary

Carbon Steel Skid, Carbon Steel Enclosure, Carbon Steel Fuel Tank. *Length and Height measurements include tank.

Options / Subcomponent Summary

Engine: Mercedes-Benz ; Alternator: Marathon ; Radiator: Nissens ; Enclosure: Rolls-Royce Solutions America Inc. ; Fuel Tank: Rolls-Royce Solutions America Inc. ; Silencer: Phillips & Temro ; Air Filter: Baldwin ; Controller: Rolls-Royce Solutions America Inc. ; Jacket Water Heater: Kim-Hotstart ; Breakers: Square-D ; Battery: Exide ; Battery Charger: SENS

UUT Properties

Weight [lbs]	Dimensions [in]			Lowest Nat. Freq. [Hz]		
	Length*	Width	Height	F-B	S-S	V
12,020	180	48	130	7.4	6.8	7.2

UUT Highest Passed Seismic Run Information

Building Code	Test Criteria	S _{DS} (g)	z/h	I _p	A _{FLX-H}	A _{RIG-H}	A _{FLX-V}	A _{RIG-V}
CBC 2019	ICC-ES AC156	2.5	0	1.5	-	-	1.67	0.67
		2.0	1	1.5	3.20	2.40	-	-

Test Mounting Details

UUT-05 was bolted to the tank using Qty (10) 5/8" dia SAE Grade 8 Bolts. The tank was rigidly attached to the shake table using Qty (10) 5/8" dia SAE Grade 8 Bolts.



All units were filled with contents and maintained structural integrity and functionality



UNIT UNDER TEST (UUT) Summary Sheet

UUT-06A

PEER STI 2015-17; UUT-6A

Model Line	Model Number	Manufacturer
OM926	<i>mtu</i> 6R0120DS200	Rolls-Royce Solutions America Inc.

Product Construction Summary

Carbon Steel Skid, Aluminum Enclosure, Carbon Steel Fuel Tank. *Length and Height measurements include tank.

Options / Subcomponent Summary

Engine: Mercedes-Benz ; Alternator: Marathon ; Radiator: Nissens ; Enclosure: Rolls-Royce Solutions America Inc. ; Fuel Tank: Rolls-Royce Solutions America Inc. ; Silencer: Phillips & Temro ; Air Filter: Baldwin ; Controller: Rolls-Royce Solutions America Inc. ; Jacket Water Heater: Kim-Hotstart ; Breakers: Square-D ; Battery: Exide ; Battery Charger: SENS ; Battery Charger: Guest

UUT Properties

Weight [lbs]	Dimensions [in]			Lowest Nat. Freq. [Hz]		
	Length*	Width	Height	F-B	S-S	V
18,320	270	48	130	3.9	4.9	8.4

UUT Highest Passed Seismic Run Information

Building Code	Test Criteria	S _{DS} (g)	z/h	I _p	A _{FLX-H}	A _{RIG-H}	A _{FLX-V}	A _{RIG-V}
CBC 2019	ICC-ES AC156	2.5	0	1.5	-	-	1.67	0.67
		2.0	1	1.5	3.20	2.40	-	-

Test Mounting Details

UUT-06A was connected to (8) VMC MSSH-1E isolators using Qty (8) 3/4" Grade 5 bolts. The isolators were connected to the fuel tank using (32) 3/4" bolts total. The fuel tank was attached to the shake table using Qty (20) 5/8" dia SAE Grade 8 Bolts.



All units were filled with contents and maintained structural integrity and functionality



UNIT UNDER TEST (UUT) Summary Sheet

UUT-06B

PEER STI 2015-17; UUT-6B

Model Line	Model Number	Manufacturer
OM926	<i>mtu</i> 6R0120DS200	Rolls-Royce Solutions America Inc.

Product Construction Summary

Carbon Steel Skid, Aluminum Enclosure

Options / Subcomponent Summary

Engine: Mercedes-Benz ; Alternator: Marathon ; Radiator: Nissens ; Enclosure: Rolls-Royce Solutions America Inc. ; Silencer: Phillips & Temro ; Air Filter: Baldwin ; Controller: Rolls-Royce Solutions America Inc. ; Jacket Water Heater: Kim-Hotstart ; Breakers: Square-D ; Battery: Exide ; Battery Charger: SENS ; Battery Charger: Guest

UUT Properties						
Weight [lbs]	Dimensions [in]			Lowest Nat. Freq. [Hz]		
	Length	Width	Height	F-B	S-S	V
5,060	120	48	100	3.9	5.9	10.6

UUT Highest Passed Seismic Run Information								
Building Code	Test Criteria	S _{DS} (g)	z/h	I _p	A _{FLX-H}	A _{RIG-H}	A _{FLX-V}	A _{RIG-V}
CBC 2019	ICC-ES AC156	2.5	0	1.5	-	-	1.67	0.67
		2.0	1	1.5	3.20	2.40	-	-

Test Mounting Details

UUT-06B was isolated using Qty (8) VMC MSS-3E-1600 spring vibration isolators. The isolators were connected to the fixture using Qty (32) 5/8" dia SAE Grade 8 Bolts.



All units were filled with contents and maintained structural integrity and functionality



UNIT UNDER TEST (UUT) Summary Sheet

UUT-09

31444-2001; UUT-7a

Model Line	Model Number	Manufacturer
mtu 8V0110GS150	mtu 8V0110GS150	Rolls-Royce Solutions America Inc.

Product Construction Summary

Carbon Steel Skid; Aluminum Enclosure; Aluminum Scoop;

Options / Subcomponent Summary

Engine: PSI ; Radiator: PSI ; Enclosure: Rolls-Royce Solutions America Inc. ; Scoop: Rolls-Royce Solutions America Inc. ; Alternator: Marathon ; Silencer: Miratech ; Air Filter: Donaldson ; Controller: Rolls-Royce Solutions America Inc. ; Jacket Water Heater: Kim Hotstart ; Breakers: Square D ; Distribution Panel: Rolls-Royce Solutions America Inc. ; Battery: Exide ; Battery Charger: Marinco ; Lighting Kit: Rolls-Royce Solutions America Inc. ; Space Heater: King ; Battery Warning Plate: Zero Start ; Louver: Rolls-Royce Solutions America Inc. ; Louver: Vent Products

UUT Properties						
Weight [lbs]	Dimensions [in]			Lowest Nat. Freq. [Hz]		
	Length	Width	Height	F-B	S-S	V
4,550	132	48	79	5.0	7.0	14.0

UUT Highest Passed Seismic Run Information								
Building Code	Test Criteria	S _{DS}	z/h	I _p	A _{FLX-H}	A _{RIG-H}	A _{FLX-V}	A _{RIG-V}
CBC 2019	ICC-ES AC156	2.5	0	1.5	-	-	1.67	0.67
		2.0	1	1.5	3.20	2.40	-	-

Test Mounting Details

UUT-09 was rigidly mounted to the shake test fixture using Qty (6) Grade 8, 5/8" diameter bolts with round washers and nuts. A pre-test Design Change Requirement was made for the radiator mounting support braces, adding a second mounting hole and increasing the width of the mounting plate per part numbers: XG2541100023 and XG2541100024.

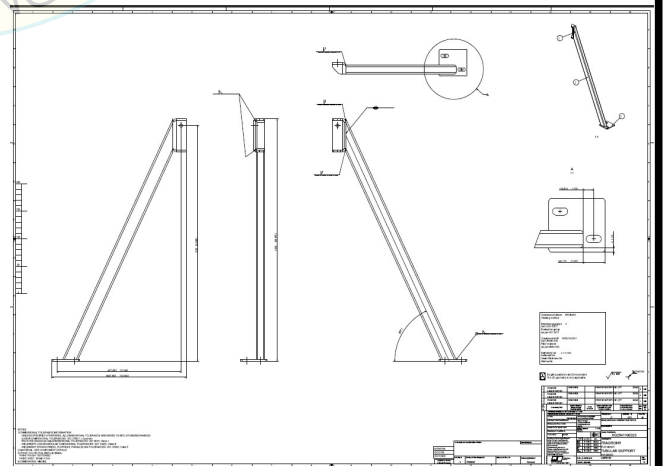

All units were filled with contents and maintained structural integrity and functionality after AC-156 test.



UNIT UNDER TEST (UUT) Summary Sheet

UUT-10A

31444-2001; UUT-8a

Model Line	Model Number	Manufacturer
150kW Genset Enclosures and Scoops	Enclosure: XSG25300.00459 Scoop: XSG25300.00465	Rolls-Royce Solutions America Inc.

Product Construction Summary

Carbon Steel Enclosure, Carbon Steel Scoop, Carbon Steel Skid

Options / Subcomponent Summary

Enclosure: Rolls-Royce Solutions America Inc. ; Scoop: Rolls-Royce Solutions America Inc. ; Skid: Rolls-Royce Solutions America Inc.

UUT Properties						
Weight [lbs]	Dimensions [in]			Lowest Nat. Freq. [Hz]		
	Length	Width	Height	F-B	S-S	V
1,170	132	48	79	9.0	8.5	>33.3

UUT Highest Passed Seismic Run Information									
Building Code	Test Criteria	S _{DS}	z/h	I _p	A _{FLX-H}	A _{RIG-H}	A _{FLX-V}	A _{RIG-V}	
CBC 2019	ICC-ES AC156	2.5	0	1.5	-	-	1.67	0.67	
		2.0	1	1.5	3.20	2.40	-	-	

Test Mounting Details

UUT-10A was rigidly mounted to the shake test fixture using Qty (6) Grade 8, 5/8" diameter bolts with round washers and nuts.



All units were filled with contents and maintained structural integrity and functionality after AC-156 test.



UNIT UNDER TEST (UUT) Summary Sheet

UUT-10B

31444-2001; UUT-8b

Model Line	Model Number	Manufacturer
150kW Genset Enclosures and Scoops	Enclosure: XSG25300.00459 Scoop: XSG25300.00465	Rolls-Royce Solutions America Inc.

Product Construction Summary

Carbon Steel Enclosure, Carbon Steel Scoop, Carbon Steel Skid

Options / Subcomponent Summary

Enclosure: Rolls-Royce Solutions America Inc. ; Scoop: Rolls-Royce Solutions America Inc. ; Skid: Rolls-Royce Solutions America Inc.

UUT Properties						
Weight [lbs]	Dimensions [in]			Lowest Nat. Freq. [Hz]		
	Length	Width	Height	F-B	S-S	V
1,170	132	48	79	4.0	4.5	12.0

UUT Highest Passed Seismic Run Information								
Building Code	Test Criteria	S _{DS}	z/h	I _p	A _{FLX-H}	A _{RIG-H}	A _{FLX-V}	A _{RIG-V}
CBC 2019	ICC-ES AC156	2.5	0	1.5	-	-	1.67	0.67
		2.0	1	1.5	3.20	2.40	-	-

Test Mounting Details

UUT-10B was mounted to (2) MSSH-1E-1200 and (4) MSSH-1E-1400 Isolators using (6) 3/4" Grade 8 bolts, nuts, and round washers. The isolators were mounted to the shake table using (4) 1/2" Grade 8 bolts, round washers, and nuts each.



All units were filled with contents and maintained structural integrity and functionality after AC-156 test.