



DEPARTMENT OF HEALTH CARE ACCESS AND INFORMATION
FACILITIES DEVELOPMENT DIVISION

APPLICATION FOR HCAI SPECIAL SEISMIC
CERTIFICATION PREAPPROVAL (OSP)

OFFICE USE ONLY

APPLICATION #: OSP-0777

HCAI Special Seismic Certification Preapproval (OSP)

Type: New Renewal

Manufacturer Information

Manufacturer: Nortek Air Solutions, LLC

Manufacturer's Technical Representative: Preston Harris

Mailing Address: 19855 SW 124th Ave., Tualatin, OR 97062

Telephone: (503) 403-4431 Email: preston.harris@nortek.com

Product Information

Product Name: Air Conditioning Units

Product Type: Air Conditioning Units - Custom

Product Model Number: Huntair Stack Air Handling Units

General Description: Custom air conditioners, sheet metal construction.

Mounting Description: Rigid, Floor Mounted

Tested Seismic Enhancements: Seismic enhancements made to the test units and/or modifications required to address anomalies during the tests shall be incorporated into the production units.

Applicant Information

Applicant Company Name: Pre Compliance

Contact Person: Katie Braman

Mailing Address: 36 SW Wall St, Bend, OR 97702-3425

Telephone: (541) 241-2310 Email: katie@go-pre.com

Title: Principal & Program Manager

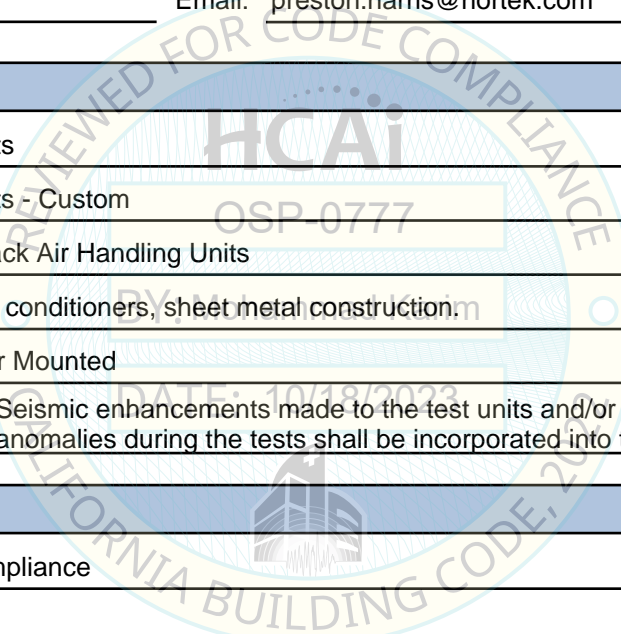



**DEPARTMENT OF HEALTH CARE ACCESS AND INFORMATION
FACILITIES DEVELOPMENT DIVISION**

California Licensed Structural Engineer Responsible for the Engineering and Test Report(s)

Company Name: PRE COMPLIANCE
Name: Andrew Coughlin California License Number: S6082
Mailing Address: 36 SW Wall Street, Bend, OR 97702
Telephone: (415) 635-8461 Email: Andy@go-pre.com

Certification Method

GR-63-Core ICC-ES AC156 IEEE 344 IEEE 693 NEBS 3
 Other (Please Specify): _____

Testing Laboratory

Company Name: U.S. ARMY ENGINEER RESEARCH AND DEVELOPMENT CENTER, CONSTRUCTION ENGINEERING RESEARCH LABORATORY (CERL)
Contact Person: James Wilcoski
Mailing Address: 2902 Newmark Dr., Champaign IL 61822-1076
Telephone: (217) 373-6763 Email: James.wilcoski@usace.army.mil

Company Name: CLARK TESTING LABORATORY, INC.
Contact Person: Davon Lohr
Mailing Address: 1801 Route 51, Jefferson Hills PA 15025
Telephone: (412) 387-1001 Email: dlohr@clarktesting.com

Company Name: Pacific Earthquake Engineering Research Center (PEER)
Contact Person: Amarnath Kasalanati
Mailing Address: 1301 South 46th St., Bldg. 420, Richmond CA 94720-1729
Telephone: (510) 642-3437 Email: Amarnath1@berkeley.edu



**DEPARTMENT OF HEALTH CARE ACCESS AND INFORMATION
FACILITIES DEVELOPMENT DIVISION**

Seismic Parameters

Design Basis of Equipment or Components (F_p/W_p) = 1.03 (z/h = 1.0); 0.62 (z/h = 0.0)

SDS (Design spectral response acceleration at short period, g) = 1.37

a_p (Amplification factor) = 2.5

R_p (Response modification factor) = 6.0

Ω_0 (System overstrength factor) = 2.0

I_p (Importance factor) = 1.5

z/h (Height ratio factor) = 1

Natural frequencies (Hz) = See Attachment

Overall dimensions and weight = See Attachment

HCAI Approval (For Office Use Only) - Approval Expires on 10/18/2029

Date: 10/18/2023

Name: Mohammad Karim

Title: Supervisor, Health Facilities

Special Seismic Certification Valid Up to: SDS (g) = 1.37

z/h = 1

Condition of Approval (if applicable): _____

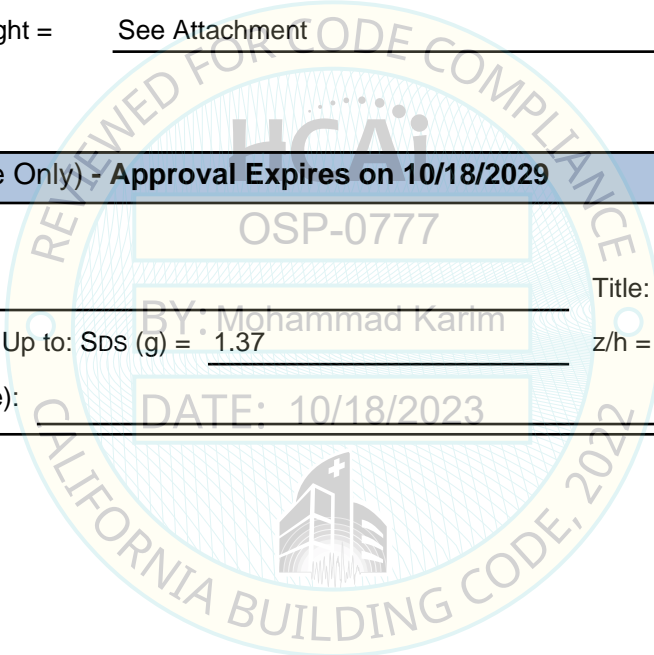

Manufacturer: Nortek Air Solutions, LLC
Product Type: Air Handling Units – Custom
Model Line: Huntair Stack Air Handling Units

Seismic Parameters

$S_{DS} = 1.37g$ for $z/h=1$ $I_p = 1.5$
 $S_{DS} = 1.37g$ for $z/h=0$

Building Codes

CBC 2022

TABLE 1 Mounting Configuration: Base Mounted - Rigid

Construction Summary

Stacked galvanized carbon steel.

Options Summary

See Tables 5 through 13 for certified options in lower section. See Tables 2 through 4 for certified option in upper section.

Model Line	Model	Max. Dimensions (in)			Wt. (lb)	Notes	UUT	
		D	W	H				
Huntair CSU Series Lower & Upper Sections of Stack Air Handling Units ¹	Upper Section CSU - 4 Walls	24	24	24	-	Lower Range	Extrap	
			Extrap	
		107	84	44	2,996	UUT: 48 psf, Galv. Carbon Stl	9	
			Interp	
		132	146	48	5,975	UUT: 45 psf, Galv. Carbon Stl	10	
			Extrap	
		132	146	48	-	Upper Range, <48 psf, Galv. Carbon Stl	Extrap	
		Lower Section CSU - 4 Walls	24	24	24	-	Lower Range	Extrap
				Extrap
			222	84	44	6,947	UUT: 54 psf, Galv. Carbon Stl	9
				Interp
			144	146	82	6,283	UUT: 43 psf, Galv. Carbon Stl	10
				Extrap
			No Limit	146	82	-	Upper Range, <54 psf, Galv. Carbon Stl	Extrap

Notes:
 UUT 9 - upper and lower section total tested weight 9,943 lbs.
 UUT 10 - upper and lower section total tested weight 12,258 lbs.
¹Based on UUTs 1-8, with split at 222" max for any lower section below an upper section.

Manufacturer: Nortek Air Solutions, LLC
Product Type: Air Handling Units – Custom
Model Line: Huntair Stack Air Handling Units

Seismic Parameters

$S_{DS} = 1.37g$ for $z/h=1$ $I_p = 1.5$
 $S_{DS} = 1.37g$ for $z/h=0$

Building Codes

CBC 2022

TABLE 2 **Upper Section: Dampers**

Component (Manufacturer)	Model	Dimensions (in)			Wt. (lb)	Materials	UUT
		D	W	H			
Damper (Ruskin)	CD 50	5	8	6	2	Aluminum Frame and Blades	Extrap
			Extrap
		5	19.5	24	23		9
			Interp
		5	24	30	35		9
			Interp
		5	100	24	118		10
			Interp
		5	96	28	131		10

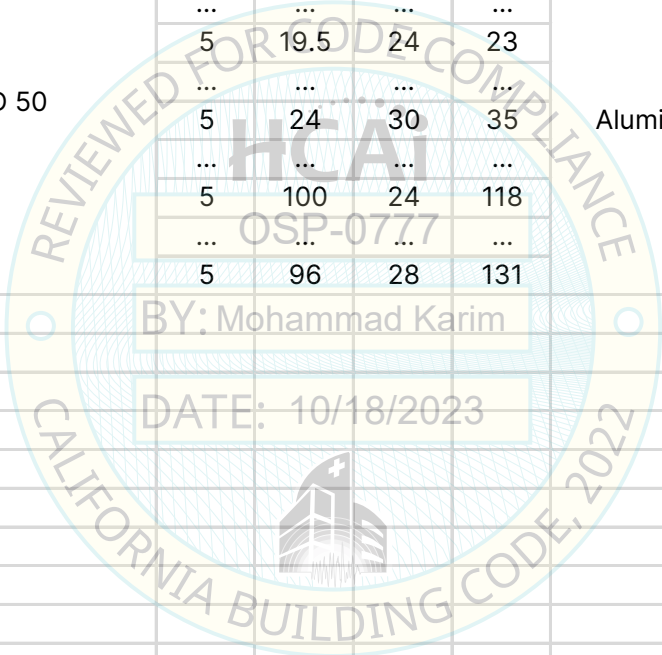

Manufacturer: Nortek Air Solutions, LLC
Product Type: Air Handling Units – Custom
Model Line: Huntair Stack Air Handling Units

Seismic Parameters
 $S_{DS} = 1.37g$ for $z/h=1$ $I_p = 1.5$
 $S_{DS} = 1.37g$ for $z/h=0$

Building Codes
CBC 2022

TABLE 3 **Upper Section: Fanwall**

Component (Manufacturer)	Model	Dimensions (in)			Wt. (lb)	Notes	UUT	
		D	W	H				
Fanwall Gen II (Huntair) ¹	10" Fan Wheel	16	22	24	54		Extrap	
			Extrap	
		24	22	27	82		Extrap	
			Extrap	
		42	30	30	157		Extrap	
	12" Fan Wheel	16	24	24	57		Extrap	
			Extrap	
		23	32	32	124		Extrap	
			Interp	
		22	25	32	130	3 wide x 1 high Gen II	9	
	14" Fan Wheel		Interp	
		42	32	32	166		Interp	
		17	25	24	57		Interp	
			Interp	
		22	25	33	100	3 wide x 1 high Gen II	9	
	16" Fan Wheel		Interp	
		42	34	34	173		Interp	
		18	28	28	66		Interp	
	18" Fan Wheel		Interp	
		48	38	38	195		Interp	
		21	31	28	74		Interp	
	20" Fan Wheel		Interp	
		48	40	40	199		Interp	
		21	31	28	74		Interp	
		20" Fan Wheel		Interp	
			37	24	28	183	4 wide x 1 high Gen II	10

Notes:
¹Carbon steel frame, aluminum fan wheels, vertical or horizontal flow

Manufacturer: Nortek Air Solutions, LLC
Product Type: Air Handling Units – Custom
Model Line: Huntair Stack Air Handling Units

Seismic Parameters

$S_{DS} = 1.37g$ for $z/h=1$ $I_p = 1.5$
 $S_{DS} = 1.37g$ for $z/h=0$

Building Codes

CBC 2022

TABLE 5 Lower Section: Dampers & Louvers

Component (Manufacturer)	Model	Dimensions (in)			Wt. (lb)	Notes	UUT
		D	W	H			
Damper: HD6 (Huntair)	HD6	8	8	6	2	Galv. Carbon Steel & Aluminum Frame, Aluminum Blades	Extrap
			Extrap
		8	48	30	120	UUT: Actuator: Belimo AS-120S	1
		Aluminum Frame Blades	Interp
		8	100	120	1000	Actuator: Belimo 24V Mo. AF24-MFT	3
Damper: CD (Ruskin)	CD 50	5	8	6	2		Extrap
			Extrap
		5	24	30	35		9
			Interp
		5	60	36	105	Actuator: Belimo AS-120-S	2
			Interp
		5	96	36	168		10
			Interp
		5	60	120	350	Actuator: Belimo AFBUP-S	8
...		Interp		
Damper: AMS (Ruskin)	AMS 050	15	6	6	3	AMS 050: Galv. Carbon Steel & Aluminum Blades	Extrap
			Extrap
		15	24	36	60	Actuator: Belimo AF120	4
			Interp
Damper: SD (Ruskin)	SD 50	15	48	96	320	Actuator: Belimo AF120	4
		5	8	5	2	SD 50: Aluminum Frame and Blades	Extrap
			Extrap
		5	33	58	78	Actuator: Honeywell MS4120F	4
			Interp
5	120	96	480	Actuator: Honeywell MS4120F	4		

Manufacturer: Nortek Air Solutions, LLC
Product Type: Air Handling Units – Custom
Model Line: Huntair Stack Air Handling Units

Seismic Parameters

$S_{DS} = 1.37g$ for $z/h=1$ $I_p = 1.5$
 $S_{DS} = 1.37g$ for $z/h=0$

Building Codes

CBC 2022

TABLE 5 Lower Section: Dampers & Louvers

Component (Manufacturer)	Model	Dimensions (in)			Wt. (lb)	Notes	UUT
		D	W	H			
Damper: Tamco 1000 (Tamco)	Tamco 1000	4	8	6	2	Tamco 1000: Aluminum Frame & Blades	Extrap
			Extrap
		4	60	30	60	Actuator: Belimo AMB24	6
		Actuator: Belimo AMB24	Interp
Louver: HL (Huntair)	HL	4	36	120	150	Galv. Carbon Steel Frame & Blades	6
		6	26	60	35		1
			Interp
Louver: ELF (Ruskin)	ELF	4	60	120	290	Aluminum Frame & Blades	8
		6	40	36	50		2
Louver: AML (Ruskin)	AML	6	60	120	200	Aluminum Frame & Blades	Interp
		3	12	20	8		Extrap
			Extrap
		6	36	60	180		4
Louver: EME (Ruskin)	EME	Aluminum Frame & Blades UUT4: Tested with AML	Interp
		3	100	120	1000		4
		3	12	20	8		Extrap
			Extrap
		6	36	60	150		4
		3	100	120	850		Interp
							4

Manufacturer: Nortek Air Solutions, LLC
Product Type: Air Handling Units – Custom
Model Line: Huntair Stack Air Handling Units

Seismic Parameters

$S_{DS} = 1.37g$ for $z/h=1$ $I_p = 1.5$
 $S_{DS} = 1.37g$ for $z/h=0$

Building Codes

CBC 2022

TABLE 6 Lower Section: Fanwall

Component (Manufacturer)	Model	Dimensions (in)			Wt. (lb)	Notes	UUT	
		D	W	H				
Fanwall: Welded or Riveted (Huntair) ¹	10" Fan Wheel	24	20	20	133		Extrap	
			Extrap	
		32	24	20	173	UUT2: Welded construction, vertical flow, UUT3a: riveted, multi. Stack and adjacent cell, horizontal flow	2 ² ,3	
	12" Fan Wheel		Interp	
		44	36	44	356		Interp	
		24	20	20	140		Interp	
	14" Fan Wheel		Interp	
		44	36	44	365		Interp	
		24	24	20	140		Interp	
	16" Fan Wheel		Interp	
		44	36	44	365		Interp	
		32	28	20	204		Interp	
	18" Fan Wheel		Interp	
		48	44	44	367		Interp	
		32	28	20	207		Interp	
	20" Fan Wheel		Interp	
		32	28	20	210		Interp	
			Interp	
	22" Fan Wheel	48	44	44	367		Interp	
		32	36	20	244		Interp	
			Interp	
			32	44	44	367	UUT2: Welded construction, vertical flow, UUT3a: riveted, multi. Stack and adjacent cell, horizontal flow	2 ² ,3

Notes:

¹Carbon steel frame, aluminum fan wheels, vertical or horizontal flow, stacked up to 131" high

²Subcomponents were tested in all UUT configurations as seen in the UUT Summaries.

Manufacturer: Nortek Air Solutions, LLC
Product Type: Air Handling Units – Custom
Model Line: Huntair Stack Air Handling Units

Seismic Parameters

$S_{DS} = 1.37g$ for $z/h=1$ $I_p = 1.5$
 $S_{DS} = 1.37g$ for $z/h=0$

Building Codes

CBC 2022

TABLE 6 Lower Section: Fanwall

Component (Manufacturer)	Model	Dimensions (in)			Wt. (lb)	Notes	UUT
		D	W	H			
Fanwall Gen II (Huntair) ¹	10" Fan Wheel	16	22	24	54		Extrap
			Extrap
		24	22	27	82	2 wide x 5 high Gen II multi stack without extended coplanar	7
			Interp
		42	30	30	157		Interp
	12" Fan Wheel	16	24	24	57		Interp
			Interp
		23	32	32	124	2 wide x 4 high Gen II multi stack without extended coplanar	4
			Interp
		22	25	32	130	3 wide x 1 high Gen II	9
			Interp
		42	32	32	166		Interp
	14" Fan Wheel	17	25	24	57		Interp
			Interp
		22	25	33	100	3 wide x 1 high Gen II	9
			Interp
	16" Fan Wheel	42	34	34	173		Interp
		18	28	28	66		Interp
			Interp
	18" Fan Wheel	48	38	38	195		Interp
		21	31	28	74		Interp
			Interp
	20" Fan Wheel	48	40	40	199		Interp
		21	31	28	74		Interp
			Interp
		37	24	28	183	4 wide x 1 high, Gen II	10
	22" Fan Wheel		Interp
		50	42	42	199		Interp
22		34	34	83		Interp	

Notes:

¹Bolted aluminum extrusion frame, aluminum & polymer fan wheels, stacked up to 144" high, horizontal flow, with or without extended coplanar

Manufacturer: Nortek Air Solutions, LLC
Product Type: Air Handling Units – Custom
Model Line: Huntair Stack Air Handling Units

Seismic Parameters

$S_{DS} = 1.37g$ for $z/h=1$ $I_p = 1.5$
 $S_{DS} = 1.37g$ for $z/h=0$

Building Codes

CBC 2022

TABLE 7 Lower Section: Heat Transfer Coils

Component (Manufacturer)	Model	Dimensions (in)			Wt. (lb)	Notes	UUT
		D	W	H			
Water Coils (Nortek Air Solutions)	5WC 1-2 Row ¹	4	24	24	57	0.625Φ tube, 1 row, 0.006" (Cu) or 0.008" (Al) fins, 6 FPI	Extrap
			Extrap
		4	40	85.5	230	0.625Φ tube, 1 row, 0.006" (Cu) or 0.008" (Al) fins, 7 FPI, stacked 2 high (UUT Aluminum)	1a
			Interp
		5.5	135.8	35	614	0.625Φ tube, 1 row, 0.006" (Cu) or 0.008" (Al) fins, 14 FPI, stacked 2 high (UUT Aluminum)	10
			Interp
		7	127	40.5	540	0.625Φ tube, 2 row, 0.006" (Cu) or 0.008" (Al) fins, 14 FPI, stacked 3 high (UUT Aluminum)	2
		6.5	24	24	143	0.625Φ tube, 3 row, 0.006" (Cu) or 0.008" (Al) fins, 14 FPI	Interp
			Interp
		8.75	79.25	33	690	0.625Φ tube, 5 row, 0.006" (Cu) or 0.008" (Al) fins, 11 FPI, (UUT Copper)	9
			Interp
		17.5	83	40.5	1,435	0.625Φ tube, 12 row, 0.006" (Cu) or 0.008" (Al) fins, 6 FPI, stacked 2 high (UUT Copper)	1a
			Interp
		10	134.5	35	2,165	0.625Φ tube, 6 row, 0.006" (Cu) or 0.008" (Al) fins, 10 FPI, stacked 2 high (UUT Aluminum)	10

Notes:
¹Copper or aluminum fins; copper tubes
²Upgraded coil support per description in UUT8

Manufacturer: Nortek Air Solutions, LLC
Product Type: Air Handling Units – Custom
Model Line: Huntair Stack Air Handling Units

Seismic Parameters

$S_{DS} = 1.37g$ for $z/h=1$ $I_p = 1.5$
 $S_{DS} = 1.37g$ for $z/h=0$

Building Codes

CBC 2022

TABLE 7 Lower Section: Heat Transfer Coils

Component (Manufacturer)	Model	Dimensions (in)			Wt. (lb)	Notes	UUT
		D	W	H			
Water Coils (Nortek Air Solutions)	5WC 3-10 Row ^{1,2}		Interp
		15	184	63	3,594	0.625Φ tube, 10 row, 0.006" (Cu) or 0.008" (Al) fins, 12 FPI, stacked 2 high (UUT Aluminum)	8
			Interp
		15	184	48	5,624	0.625Φ tube, 10 row, 0.006" (Cu) or 0.008" (Al) fins, 12 FPI, stacked 2 high (UUT Copper)	8
DX Coils (Nortek Air Solutions) ¹	DX Evaporator Coil	5	24	24	33	0.5"Φ tube, 8 fins per inch, 1 row	Extrap
			Extrap
		8.5	56	45	521	0.5"Φ tube, 14 fins per inch, 6 row	4
			Interp
		8.5	150	45	1308	0.5"Φ tube, 14 fins per inch, 6 row	4
DX Coils (Heatcraft/Modine) ³	DX Evaporator Coil	5	24	24	33	0.5"Φ tube, 8 fins per inch, 1 row	Extrap
			Extrap
		8.5	56	45	521	0.5"Φ tube, 14 fins per inch, 6 row	4
			Extrap
		8.5	150	45	1308	0.5"Φ tube, 14 fins per inch, 6 row	4

Notes:
¹Copper or aluminum fins; copper tubes
²Upgraded coil support per description in UUT8
³0.0025" copper tube, 0.006" aluminum fin, 16GA galv. Carbon steel casing

Manufacturer: Nortek Air Solutions, LLC
Product Type: Air Handling Units – Custom
Model Line: Huntair Stack Air Handling Units

Seismic Parameters

$S_{DS} = 1.37g$ for $z/h=1$ $I_p = 1.5$
 $S_{DS} = 1.37g$ for $z/h=0$

Building Codes

CBC 2022

TABLE 9 Lower Section: Enclosure

Component (Manufacturer)	Model	Dimensions (in)			Wt. (lb)	Notes	UUT	
		D	W	H				
Enclosures (Huntair)	Control & VFD Enclosures ¹	12	20	24	30	NEMA 1/12/3R/4X ³	Extrap	
			Extrap	
		16	28	42	176	NEMA 1/12/3R/4X ³ , UUT:NEMA 12	2a	
			Interp	
		10	28	40	143	NEMA 1/12/3R/4X ³ , UUT:NEMA 1	4	
			Interp	
		12	36	48	216	NEMA 1/12/3R/4X ³ , UUT:NEMA 3R	1b	
			Interp	
		20	56	72	470	NEMA 1/12/3R/4X ³ , UUT:NEMA 12	1a	
			Interp	
		16	56	90	530	NEMA 1/12/3R/4X ³ , UUT:NEMA 1	4	
		Power Distribution & MSP Enclosures ¹	6	6	8	30		Extrap
				Extrap
			10	16	16	30	NEMA 1/12/3R/4X ³ , UUT:NEMA 4X	2b
...		Interp		
Enclosure (Hoffman)	Power Distribution & MSP Enclosures ²	12	22	34	105	NEMA 1/12/3R/4X ³ , UUT:NEMA 1	8	
		6	24	24	50	UUT: NEMA 3R	3	
Enclosure (Saginaw)	Electrical Control Cabinet ¹	16	30	48	190	UUT: NEMA 1	8	

Notes:
¹Material: Carbon Steel
²Material: Aluminum
³No physical difference between NEMA 1, NEMA 12, and NEMA 3R. NEMA 4X is powder coated.

Manufacturer: Nortek Air Solutions, LLC
Product Type: Air Handling Units – Custom
Model Line: Huntair Stack Air Handling Units

Seismic Parameters

$S_{DS} = 1.37g$ for $z/h=1$ $I_p = 1.5$
 $S_{DS} = 1.37g$ for $z/h=0$

Building Codes

CBC 2022

TABLE 10 Lower Section: Actuator & Fan Motors

Component (Manufacturer)	Model	Description	Material	UUT
Actuator (Belimo)	AMB24			6
	AS-120-S			1,2
	AF24-MFT	24V		3
	AF120	120V		4
	AFBUP-S	120V		8
Actuator (Honeywell)	MS4120F	2 position, 120V		4
Actuator (Siemens)	GCA156.1U			Extrap
	GCA131.1p	24V		3
	GCA226.1U	120V		3
Fan Motor (Siemens)	1 HP	230/460V, 55 lbs	Carbon Steel	2 ¹ ,3,7
	...			Interp
	10 HP	460V, 144 lbs		7
	...			Interp
	15 HP	230/460V, 218 lbs		2 ¹
	...			Interp
Fan Motor (Baldor)	20 HP	230/460V, 291 lbs	Carbon Steel	3
	1 HP	230/460V, 45 lbs		7
	...			Interp
Fan Motor (Toshiba)	12 HP	230/460V, 169 lbs	Carbon Steel	7
	1 HP	230/460V, 63 lbs		4,7
	...			Interp
	4 HP	460V, 99 lbs		9
	...			Interp
	6 HP	460V, 110 lbs		10
	...			Interp
	12 HP	230/460V, 202 lbs		7
...		Interp		
	15 HP	230/460V, 320 lbs		4

Notes:
¹Subcomponent was tested in all UUT configurations as seen in the UUT Summaries.

Manufacturer: Nortek Air Solutions, LLC
Product Type: Air Handling Units – Custom
Model Line: Huntair Stack Air Handling Units

Seismic Parameters

$S_{DS} = 1.37g$ for $z/h=1$ $I_p = 1.5$
 $S_{DS} = 1.37g$ for $z/h=0$

Building Codes

CBC 2022

TABLE 12 **Lower Section: Filter Frames & Racks**

Component (Manufacturer)	Model	Dimensions (in)			Wt. (lb)	Material	UUT
		D	W	H			
Filter Frames & Racks (Camfil, AAF, Huntair, Farr)	Rack Type 8	2.69	12	12	2	Galvanized Carbon Steel	Extrap
			Extrap
		2.69	36	72.1	20		9
			Interp
		2.69	84	84	50		1b
			Interp
		2.69	60.25	132	55		6a
			Interp
		2.69	108	108	80		5
			Interp
		2.69	228	120	175		3
	Frame - HEPA	3.75	132	120	150		2 ¹

Notes:
¹Subcomponent was tested in all UUT configurations as seen in the UUT Summaries.

UUT	Model	Test Report	Test Laboratory	S _{DS}	z/h	I _p
1a	Air Handling Cabinet CSU-10K	HuntAir9293	Clark Testing	2.0	1.0	1.5
1b	Air Handling Cabinet CSU-10K	HuntAir9293	Clark Testing	2.0	1.0	1.5
2a	Air Handling Cabinet CSU-20K	HuntAir9293	Clark Testing	2.0	1.0	1.5
2b	Air Handling Cabinet CSU-20K (Inlet Wall Removed w/Cable Bracing)	HuntAir9293	Clark Testing	2.0	1.0	1.5
2c	Air Handling Cabinet CSU-20K (Inlet & Outlet Wall Removed w/Cable Bracing)	HuntAir9293	Clark Testing	2.0	1.0	1.5
2d	Air Handling Cabinet CSU-20K (Inlet & Outlet Wall Removed w/o Cable Bracing)	HuntAir9293	Clark Testing	2.0	1.0	1.5
3	Air Handling Cabinet CSU-40K	HuntAir9293	Clark Testing	2.0	1.0	1.5
4	Air Handling Cabinet CSU-20K	1700754-TR-001 R1	CERL	2.0 2.5	1.0 0.0	1.5
5	Air Handling Cabinet CSU-15K	1700754-TR-001 R1	CERL	2.0 2.5	1.0 0.0	1.5
6a	Air Handling Cabinet CSU-15K	1700754-TR-001 R1	CERL	2.0 2.5	1.0 0.0	1.5
6b	Air Handling Cabinet CSU-15K (Filter Rack & Humidifier Removed w/ Cable Bracing)	1700754-TR-001 R1	CERL	2.0 2.5	1.0 0.0	1.5
7	FWT	13379 Rev.1	Environmental Testing Laboratory, Inc.	2.0 2.5	1.0 0.0	1.5
8	Air Handling Cabinet CSU-20K	1801166-TR-001 R0	Pacific Earthquake Engineering Research Center (PEER)	2.0 2.5	1.0 0.0	1.5
9	Double Stack AHU CSU-6K CHW	1700975-TR-001 R0 (UUT 1)	Pacific Earthquake Engineering Research Center (PEER)	1.37 1.37	1.0 0.0	1.5
10	Double Stack AHU CSU-25K HW/CHW	2101016-TR-001-R0 (UUT 1)	Pacific Earthquake Engineering Research Center (PEER)	1.495 1.495	1.0 0.0	1.5

Notes:

UUT 1a

Test Report# HuntAir9293

Manufacturer: Nortek Air Solutions, LLC
Model Line: Huntair Stack Air Handling Units
Model Number: CSU-10K
Serial Number: 2097-01

Highest Passed Test Level						
S _{DS}	z/h	I _p	A _{flx-h}	A _{rig-h}	A _{flx-v}	A _{rig-v}
2.0	1 0	1.5	3.2	2.4	1.33	0.53

Dimensions/Weights			
Depth (in)	Width (in)	Height (in)	Weight (lbs.)
96.25	96	96	7,450

Lowest Natural Frequency (Hz)		
Front-Back	Side-Side	Vertical
15.2	10.7	20.5

Building Codes
CBC 2022

Test Criteria
ICC-ES AC156

Construction/Option Summary
 Wall/Roof: Standard 2" Panels, 16 ga. galv. carbon steel exterior with 20 ga. galv. carbon steel liner; Base: Carbon steel channel base, 16 ga. galv. carbon steel skin with 20 ga. galv. carbon steel liner and 20 ga. carbon steel subfloor; Door: (2) 2" thick, 18.5(W) x 61.5(H) with thermal break window, 12.5(W) x 61.5(H) no window.
 UUT: 116 psf

UUT Mounting Details:

List of Included Subcomponents



All test units contain an integrated structural base frame. This unit was mounted directly to the seismic table using twelve (12) 1/2"-13 Grade 5 hex head bolts (3 bolts per side) with flat washers and lock washers. Unit maintained structural integrity and remained operational per manufacturer requirement following shake table test. All contents were included in the unit per operating conditions.

Description	Manufacturer
Heat Transfer Coil (HT1), 7 FPI, 1 row, aluminum, staggered mounting - qty. 2 (40"x8"x85.5")	Nortek Air Solutions
Heat Transfer Coil (HT2), 6 FPI, 12 rows, copper, stacked mounting - qty. 2 (83"x17.5"x40.5")	Nortek Air Solutions
Humidifier (5"x24"x24")	Vapac
Electrical Control Panel NEMA1 (20"x56"x78")	Huntair
ACH550 150 HP VFD	ABB
E7 150 HP VFD	Yaskawa
Damper HD6 (8"x48"x30")	Huntair
Louver HL (6"x26"x60")	Huntair
Actuator AS-120-S	Belimo
Cool Fan 120V-240V	U.S. Toyo
Disconnect Switch & Circuit Breaker	Siemens
Fuse Holder & Fuse 400A	Bussmann
Distribution Block 665A	Marathon
Contactors 7A & 150A	Siemens
MSP 45 to 50A	Siemens
Transformer 750VA	Micron

Line Drawings:

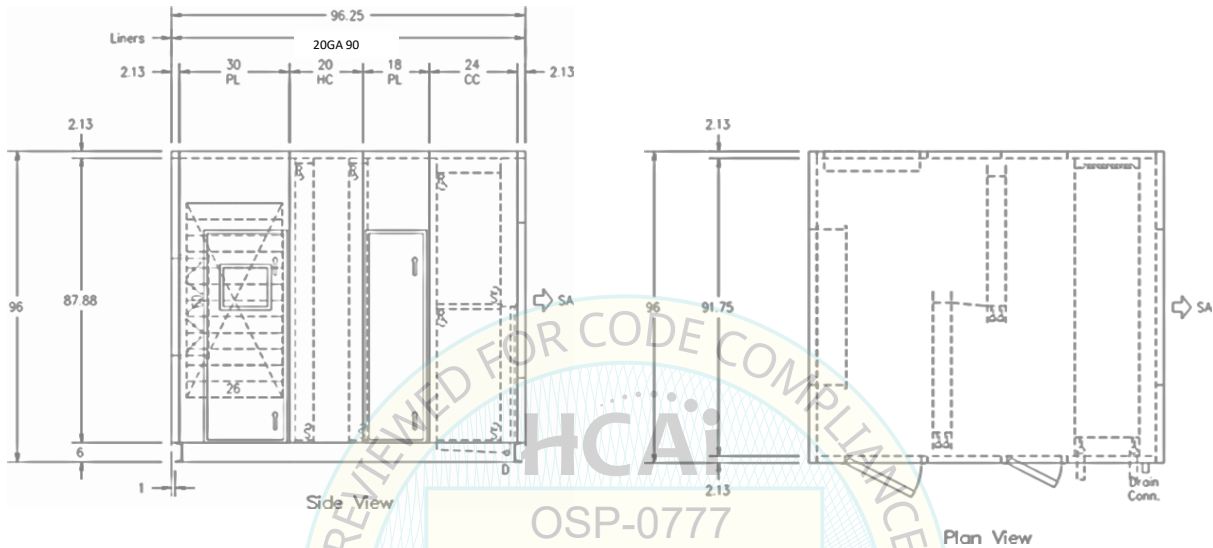

OSP-0777

BY: Mohammad Karim

DATE: 10/18/2023

Coil Support Details:

(7) 0.188" Rivets at bottom of each coil, (6) 0.188 Rivets at top of each coil, (2) 2-16ga. C-channel stiffeners each side of coil (8- total), (3) #14x1" screws at 7-5/8" o.c. max spacing along each c-channel

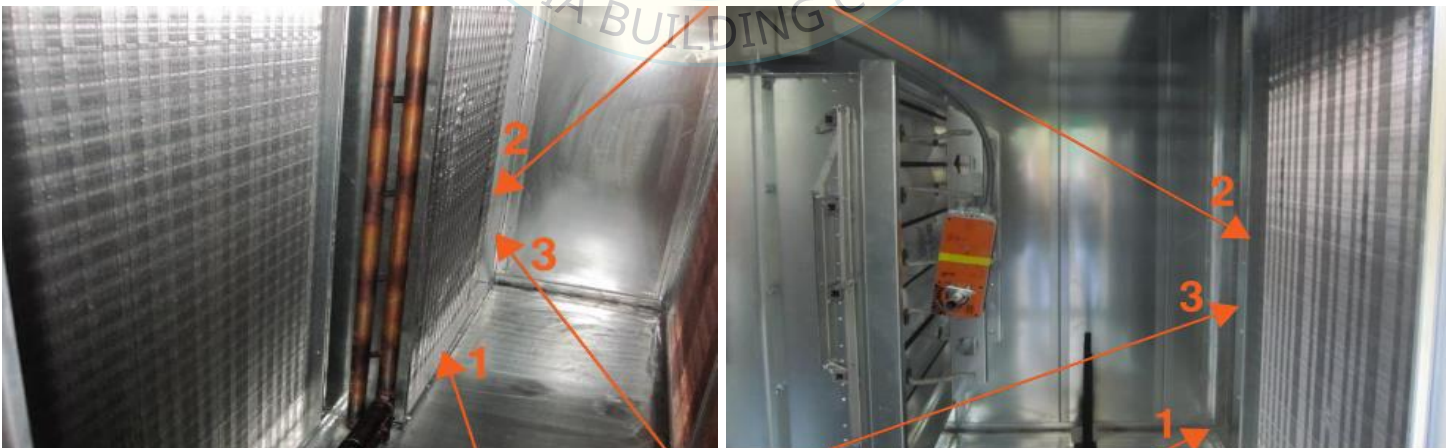

UUT 1b

Test Report# HuntAir9293

Manufacturer: Nortek Air Solutions, LLC
Model Line: Huntair Stack Air Handling Units
Model Number: CSU-10K
Serial Number: 2097-01

Highest Passed Test Level

S _{DS}	z/h	I _p	A _{flx-h}	A _{rig-h}	A _{flx-v}	A _{rig-v}
2.0	1 0	1.5	3.2	2.4	1.33	0.53

Dimensions/Weights

Depth (in)	Width (in)	Height (in)	Weight (lbs.)
96.25	96	96	7,450

Lowest Natural Frequency (Hz)

Front-Back	Side-Side	Vertical
15.2	10.7	20.5

Building Codes
CBC 2022

Test Criteria
ICC-ES AC156

Construction/Option Summary

Wall/Roof: Standard 2" Panels, 16 ga. galv. carbon steel exterior with 20 ga. galv. carbon steel liner; Base: Carbon steel channel base, 16 ga. galv. carbon steel skin with 20 ga. galv. carbon steel liner and 20 ga. carbon steel subfloor; Door: (2) 2" thick, 18.5(W) x 61.5(H) with thermal break window, 12.5(W) x 61.5(H) no window.
 UUT: 116 psf

UUT Mounting Details:

(4) Walls in place, coils removed and replaced with filter rack



This unit was mounted directly to the seismic table using twelve (12) 1/2"-13 Grade 5 hex head bolts (3 bolts per side) with flat washers and lock washers. Unit maintained structural integrity and remained operational per manufacturer requirement following shake table test. All contents were included in the unit per operating conditions.

List of Included Subcomponents

Description	Manufacturer
Filter Rack - Type 8 (2.69" x 84" x 84")	Camfil, AAD, Huntair, Farr
Final Filter (12" depth) MERV 11	Camfil
Pre Filter 30-30, Aeropleat	Camfil
Humidifier (5"x24"x24")	Vapac
Electrical Control Panel NEMA1 (20"x56"x78")	Huntair
ACS230 1 HP VFD	ABB
ACS230 20 HP VFD	ABB
V1000 Series 3 HP VFD	Yaskawa
V1000 Series 10 HP VFD	Yaskawa
V1000 Series 20 HP VFD	Yaskawa
Damper HD6 (8"x48"x30")	Huntair
Louver HL (6"x26"x60")	Huntair
Actuator AS-120-S	Belimo
Cool Fan 120V-240V	U.S. Toyo
Power Supply 4A	Siemens
Fuse Holder & Fuse 30A	Bussmann
Distribution Block 175A	Marathon
PLC Control	Siemens
Reactor 156A	TCI
Transformer 500VA	Micron

UUT 1b

Test Report# HuntAir9293

Additional Image:



Line Drawings:

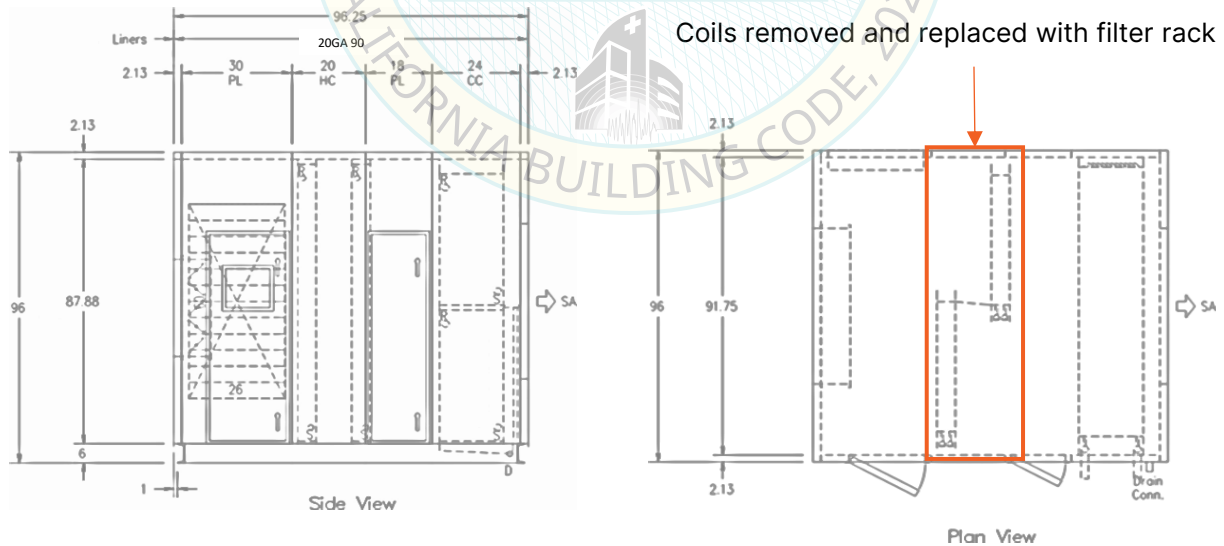

UUT 2a

Test Report# HuntAir9293

Manufacturer: Nortek Air Solutions, LLC
Model Line: Huntair Stack Air Handling Units
Model Number: CSU-20K
Serial Number: 2097-02

Highest Passed Test Level

S _{DS}	z/h	I _p	A _{flx-h}	A _{rig-h}	A _{flx-v}	A _{rig-v}
2.0	1 0	1.5	3.2	2.4	1.33	0.53

Dimensions/Weights

Depth (in)	Width (in)	Height (in)	Weight (lbs.)
108	144	144.25	9,050

Lowest Natural Frequency (Hz)

Front-Back	Side-Side	Vertical
4.0	6.6	20.6

Building Codes
CBC 2022

Test Criteria
ICC-ES AC156

Construction/Option Summary

Wall/Roof: Standard 4" Panels, 16 ga. galv. carbon steel exterior with 20 ga. galv. carbon steel liner and 16 ga. galv. carbon steel blankoff with sloped roof; Base: Carbon steel channel base, 16 ga. galv. carbon steel skin with 20 ga. galv. carbon steel liner and 20 ga. carbon steel subfloor; Door: (2) 2" thick, 18.5(W) x 61.5(H) with thermal break window, 30.5(W) x 24.5(H) no window.
 UUT: 84 psf

UUT Mounting Details:

(4) Walls in place



All test units contain an integrated structural base frame. This unit was mounted directly to the seismic table using fourteen (14) 1/2"-13 Grade 5 hex head bolts (7 bolts per exterior side) with flat washers and lock washers. Unit maintained structural integrity and remained operational per manufacturer requirement following shake table test. All contents were included in the unit per operating conditions.

List of Included Subcomponents

Description	Manufacturer
Fanwall: 3 fans, vertical upflow (2 up, 1 down), 10" and 22" wheels, welded cells, 1 HP and 15 HP Siemens motors (38.5"x131"x136")	Nortek Air Solutions
Heat Transfer Coil (HT3): Huntair, 14 FPI, 2 row, aluminum, stacked mounting - qty. 3 (127"x7"x40.5")	Nortek Air Solutions
HEPA Filter & Filter Rack (3.75"x132"x120")	Camfil, AAF, Huntair, Farr
Control & VFD Enclosure: NEMA 12 (16"x28"x42")	Huntair
VLT 100 HP VFD	Danfoss
HEPA Filter 12" Depth	Camfil & AAF
Damper CD50 (5"x60"x36")	Ruskin
Louver ELF (6"x40"x36")	Ruskin
Actuator AS-120-S	Belimo
Cool Fan 120V-240V	U.S. Toyo
Disconnect Switch & Circuit Breaker MSP 5.5 to 8.0A	Siemens
Transformer 150VA	Micron
Thermostat 120-240V	Pfennenberg

UUT 2a

Test Report# HuntAir9293

Line Drawings:

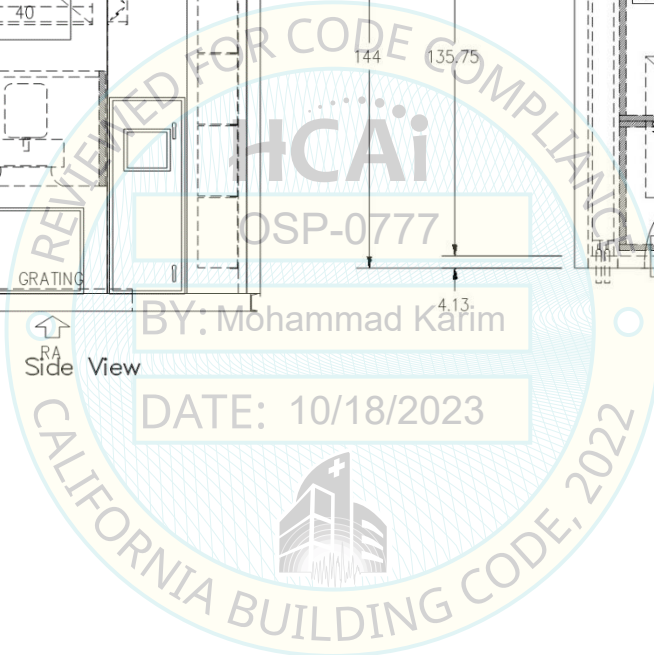
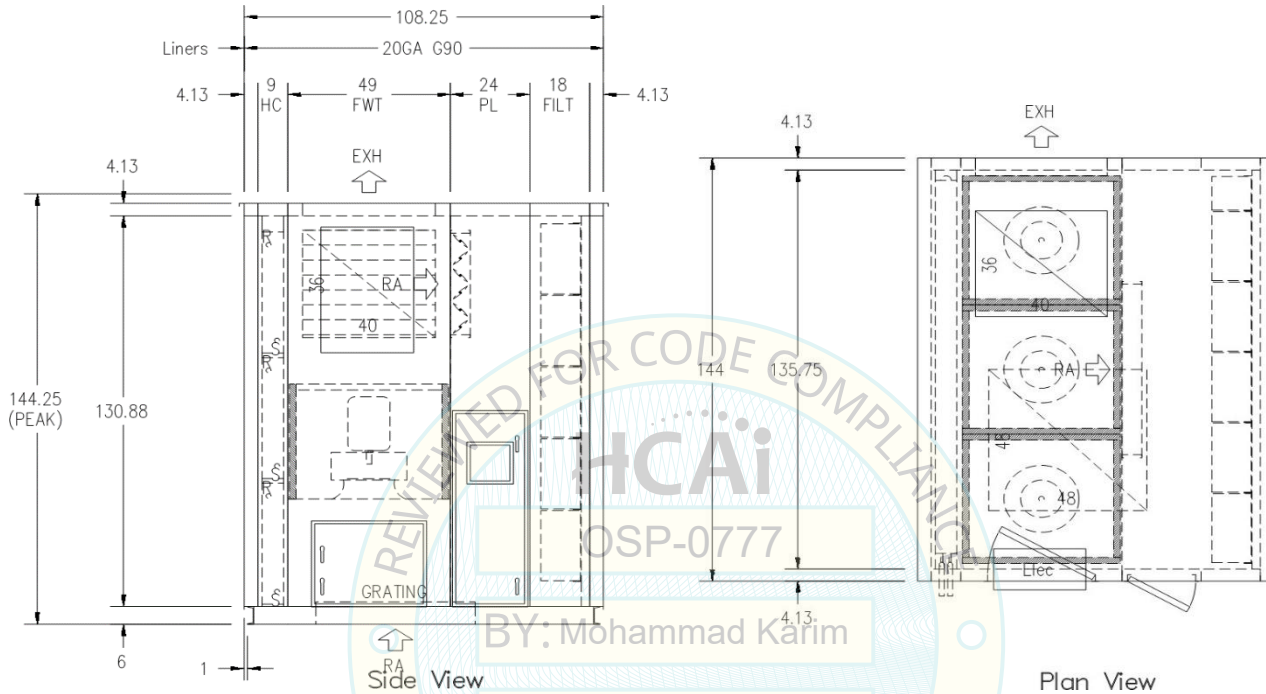

UUT 2b

Test Report# HuntAir9293

Manufacturer: Nortek Air Solutions, LLC
Model Line: Huntair Stack Air Handling Units
Model Number: CSU-20K
Serial Number: 2097-02

Highest Passed Test Level						
S _{DS}	z/h	I _p	A _{flx-h}	A _{rig-h}	A _{flx-v}	A _{rig-v}
2.0	1 0	1.5	3.2	2.4	1.33	0.53

Dimensions/Weights			
Depth (in)	Width (in)	Height (in)	Weight (lbs.)
108	144	144.25	9,050

Lowest Natural Frequency (Hz)		
Front-Back	Side-Side	Vertical
4.0	6.6	20.6

Building Codes
CBC 2022

Test Criteria
ICC-ES AC156

Construction/Option Summary
 Wall/Roof: Standard 4" Panels, 16 ga. galv. carbon steel exterior with 20 ga. galv. carbon steel liner and 16 ga. galv. carbon steel blankoff with sloped roof; Base: Carbon steel channel base, 16 ga. galv. carbon steel skin with 20 ga. galv. carbon steel liner and 20 ga. carbon steel subfloor; Door: (2) 2" thick, 18.5(W) x 61.5(H) with thermal break window, 30.5(W) x 24.5(H) no window.
 UUT: 84 psf

UUT Mounting Details:

Inlet wall removed; cable bracing at coil



All test units contain an integrated structural base frame. This unit was mounted directly to the seismic table using fourteen (14) 1/2"-13 Grade 5 hex head bolts (7 bolts per exterior side) with flat washers and lock washers. Unit maintained structural integrity and remained operational per manufacturer requirement following shake table test. All contents were included in the unit per operating conditions.

List of Included Subcomponents

Description	Manufacturer
Fanwall: 3 fans, vertical upflow (2 up, 1 down), 10" and 22" wheels, welded cells, 1 HP and 15 HP Siemens motors (38.5"x131"x136")	Huntair
Heat Transfer Coil (HT3): Huntair, 14 FPI, 2 row, aluminum, stacked mounting - qty. 3 (127"x7"x40.5")	Huntair
HEPA Filter & Filter Rack (12"x140"x140")	Camfil, AAF, Huntair, Farr
Control & VFD Enclosure: NEMA 12 (16"x28"x40")	Huntair
VLT 100 HP VFD	Danfoss
HEPA Filter 12" Depth	Camfil & AAF
Damper CD50 (5"x60"x36")	Ruskin
Louver ELF (6"x40"x36")	Ruskin
Actuator AS-120-S	Belimo
Cool Fan 120V-240V	U.S. Toyo
Disconnect Switch & Circuit Breaker MSP 5.5 to 8.0A	Siemens
Transformer 150VA	Micron
Thermostat 120-240V	Pfenningberg
MSP Enclosure (10" 16" x 16")	Huntair

UUT 2b

Test Report# HuntAir9293

Additional Images:

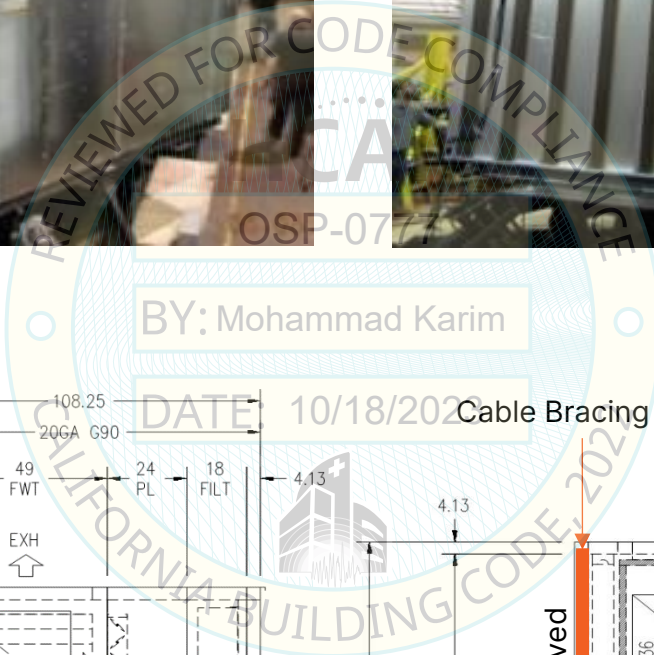

Line Drawings:

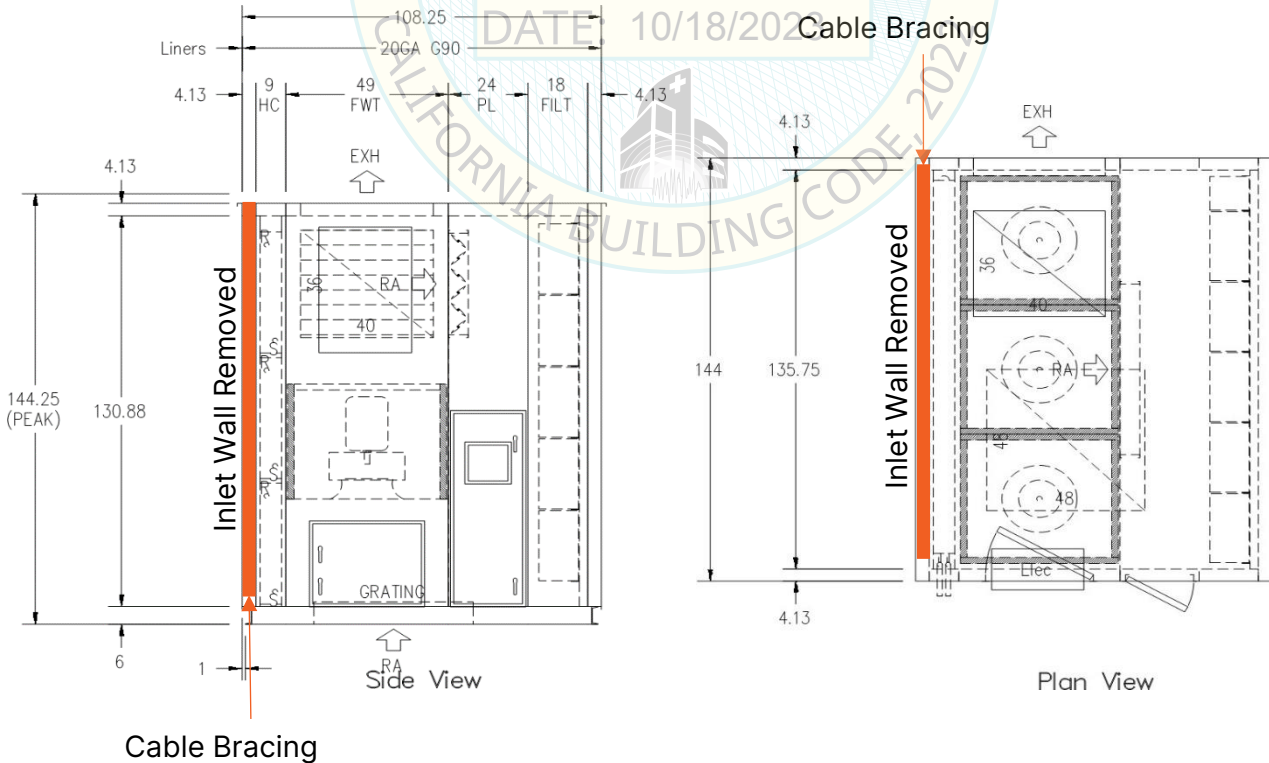

UUT 2c

Test Report# HuntAir9293

Manufacturer: Nortek Air Solutions, LLC
Model Line: Huntair Stack Air Handling Units
Model Number: CSU-20K
Serial Number: 2097-02

Highest Passed Test Level						
S _{DS}	z/h	I _p	A _{flx-h}	A _{rig-h}	A _{flx-v}	A _{rig-v}
2.0	1 0	1.5	3.2	2.4	1.33	0.53

Dimensions/Weights			
Depth (in)	Width (in)	Height (in)	Weight (lbs.)
108	144	144.25	9,050

Lowest Natural Frequency (Hz)		
Front-Back	Side-Side	Vertical
4.0	6.6	20.6

Building Codes
CBC 2022

Test Criteria
ICC-ES AC156

Construction/Option Summary
 Wall/Roof: Standard 4" Panels, 16 ga. galv. carbon steel exterior with 20 ga. galv. carbon steel liner and 16 ga. galv. carbon steel blankoff with sloped roof; Base: Carbon steel channel base, 16 ga. galv. carbon steel skin with 20 ga. galv. carbon steel liner and 20 ga. carbon steel subfloor; Door: (2) 2" thick, 18.5(W) x 61.5(H) with thermal break window, 30.5(W) x 24.5(H) no window.
 UUT: 84 psf

UUT Mounting Details:

Inlet and outlet walls removed; cable bracing at coil



All test units contain an integrated structural base frame. This unit was mounted directly to the seismic table using fourteen (14) 1/2"-13 Grade 5 hex head bolts (7 bolts per exterior side) with flat washers and lock washers. Unit maintained structural integrity and remained operational per manufacturer requirement following shake table test. All contents were included in the unit per operating conditions.

List of Included Subcomponents

Description	Manufacturer
Fanwall: 3 fans, vertical upflow (2 up, 1 down), 10" and 22" wheels, welded cells, 1 HP and 15 HP Siemens motors (38.5"x131"x136")	Huntair
Heat Transfer Coil (HT3): Huntair, 14 FPI, 2 row, aluminum, stacked mounting - qty. 3 (127"x7"x40.5")	Huntair
HEPA Filter & Filter Rack (12"x140"x140")	Camfil, AAF, Huntair, Farr
Control & VFD Enclosure: NEMA 12 (16"x28"x40")	Huntair
VLT 100 HP VFD	Danfoss
HEPA Filter 12" Depth	Camfil & AAF
Damper CD50 (5"x60"x36")	Ruskin
Louver ELF (6"x40"x36")	Ruskin
Actuator AS-120-S	Belimo
Cool Fan 120V-240V	U.S. Toyo
Disconnect Switch & Circuit Breaker MSP 5.5 to 8.0A	Siemens
Transformer 150VA	Micron
Thermostat 120-240V	Pfennenberg

Additional Images:



Line Drawings:

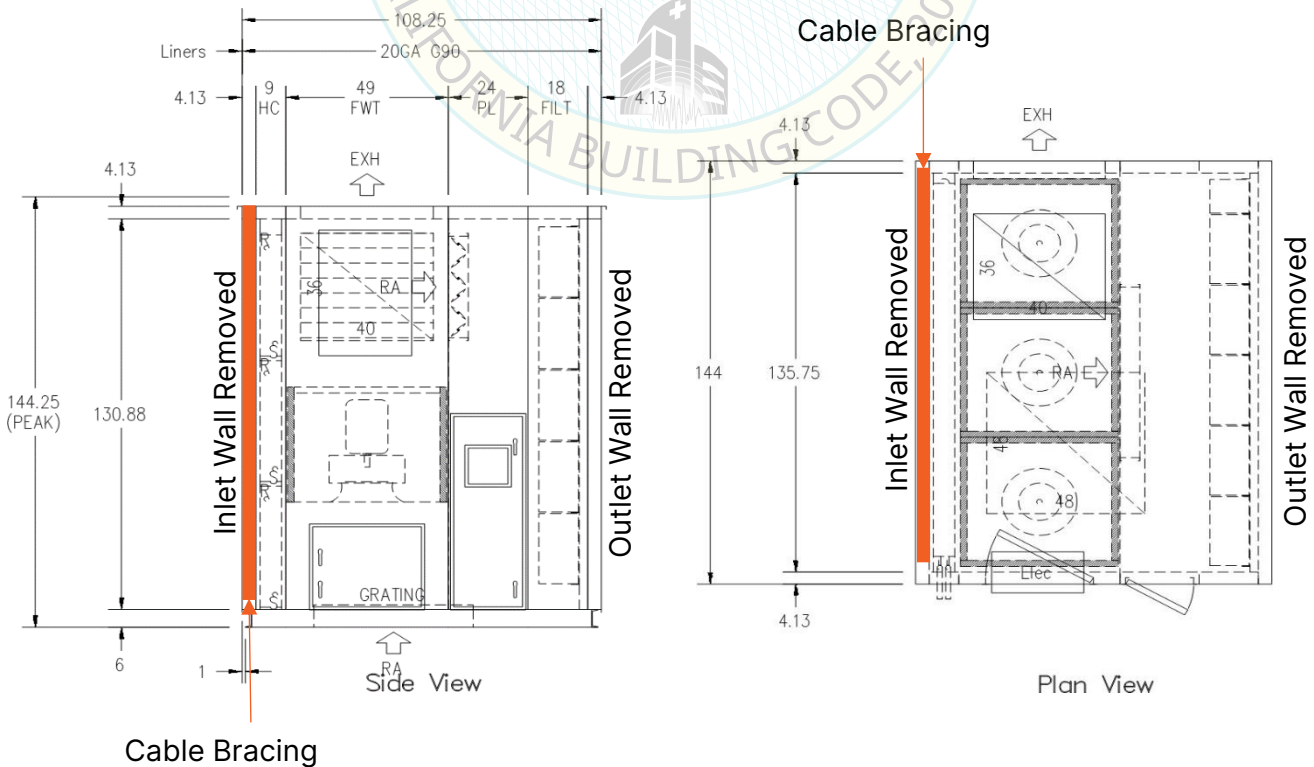

UUT 2d

Test Report# HuntAir9293

Manufacturer: Nortek Air Solutions, LLC
Model Line: Huntair Stack Air Handling Units
Model Number: CSU-20K
Serial Number: 2097-02

Highest Passed Test Level						
S _{DS}	z/h	I _p	A _{flx-h}	A _{rig-h}	A _{flx-v}	A _{rig-v}
2.0	1 0	1.5	3.2	2.4	1.33	0.53

Dimensions/Weights			
Depth (in)	Width (in)	Height (in)	Weight (lbs.)
108	144	144.25	9,050

Lowest Natural Frequency (Hz)		
Front-Back	Side-Side	Vertical
4.0	6.6	20.6

Building Codes
CBC 2022

Test Criteria
ICC-ES AC156

Construction/Option Summary
 Wall/Roof: Standard 4" Panels, 16 ga. galv. carbon steel exterior with 20 ga. galv. carbon steel liner and 16 ga. galv. carbon steel blankoff with sloped roof; Base: Carbon steel channel base, 16 ga. galv. carbon steel skin with 20 ga. galv. carbon steel liner and 20 ga. carbon steel subfloor; Door: (2) 2" thick, 18.5(W) x 61.5(H) with thermal break window, 30.5(W) x 24.5(H) no window.
 UUT: 84 psf

UUT Mounting Details:

Inlet and outlet walls removed; no cable bracing.

List of Included Subcomponents

Description	Manufacturer
Fanwall: 3 fans, vertical upflow (2 up, 1 down), 10" and 22" wheels, welded cells, 1 HP and 15 HP Siemens motors (38.5"x131"x136")	Huntair
Heat Transfer Coil (HT3): Huntair, 14 FPI, 2 row, aluminum, stacked mounting - qty. 3 (127"x7"x40.5")	Huntair
HEPA Filter & Filter Rack (12"x140"x140")	Camfil, AAF, Huntair, Farr
Control & VFD Enclosure: NEMA 12 (16"x28"x40")	Huntair
VLT 100 HP VFD	Danfoss
HEPA Filter 12" Depth	Camfil & AAF
Damper CD50 (5"x60"x36")	Ruskin
Louver ELF (6"x40"x36")	Ruskin
Actuator AS-120-S	Belimo
Cool Fan 120V-240V	U.S. Toyo
Disconnect Switch & Circuit Breaker MSP 5.5 to 8.0A	Siemens
Transformer 150VA	Micron
Thermostat 120-240V	Pfenningberg



All test units contain an integrated structural base frame. This unit was mounted directly to the seismic table using fourteen (14) 1/2"-13 Grade 5 hex head bolts (7 bolts per exterior side) with flat washers and lock washers. Unit maintained structural integrity and remained operational per manufacturer requirement following shake table test. All contents were included in the unit per operating conditions.

Additional Images:



Line Drawings:

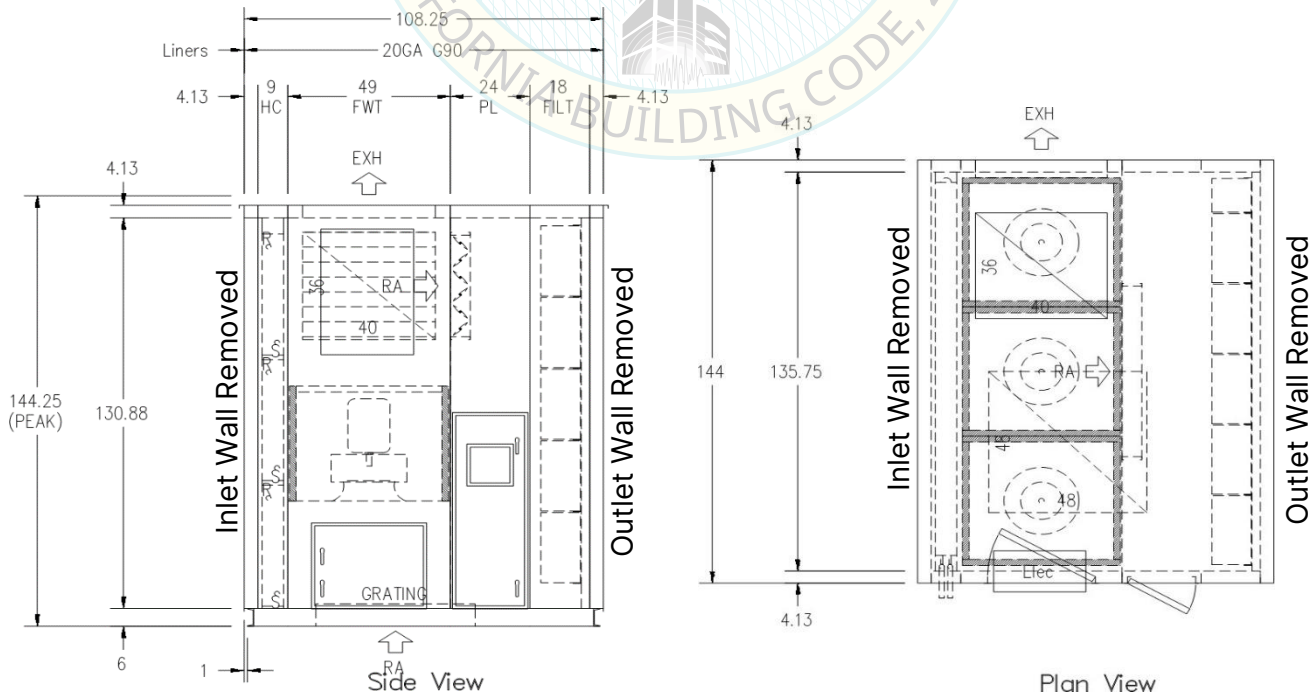

UUT 3

Test Report# HuntAir9293

Manufacturer: Nortek Air Solutions, LLC
Model Line: Huntair Stack Air Handling Units
Model Number: CSU-40K
Serial Number: 2097-03

Highest Passed Test Level						
S _{DS}	z/h	I _p	A _{flx-h}	A _{rig-h}	A _{flx-v}	A _{rig-v}
2.0	1 0	1.5	3.2	2.4	1.33	0.53

Dimensions/Weights			
Depth (in)	Width (in)	Height (in)	Weight (lbs.)
96	240	144	11,600

Lowest Natural Frequency (Hz)		
Front-Back	Side-Side	Vertical
4.7	3.9	14.1

Building Codes
CBC 2022

Test Criteria
ICC-ES AC156

Construction/Option Summary
 Wall/Roof: Standard 4" Panels, 0.080" aluminum exterior with 0.063" solid aluminum liner, 0.080" solid aluminum blankoff; Base: 6" Aluminum structural tubing, 0.125" aluminum floor liner with 0.063" aluminum base liner; Door: 2" thick, 12.5(W) x 61.5(H) no window.
 UUT:73psf

UUT Mounting Details: List of Included Subcomponents

(4) Walls in place



All test units contain an integrated structural base frame. This unit was mounted directly to the seismic table using sixteen (16) 1/2" - 13 grade 5 hex head bolts (8 bolts per both exterior sides) with flat washers and lock washers. Unit maintained structural integrity and remained operational per manufacturer requirement following shake table test. All contents were included in the unit per operating conditions.

Description	Manufacturer
Fanwall: 29 fans, 10" and 22" carbon steel wheels, horizontal standard 5 cell(W) x 7 cell(H), welded/riveted cells, back draft dampers, 1 HP and 20 HP Siemens motors (34"x212"x131")	Huntair
Filter Rack-Type 8 (2.69"x228"x120")	Camfil, AAF, Huntair, Farr
Pre Filter 4"	Camfil
Final Filter 12"	AAF
Disconnect Switch & Circuit Breaker	Siemens
MSP 11A to 16A	Siemens
Thermostat 120-240V	Pfenningberg
VLT 100 HP VFD	Danfoss
Cool Fan 120V-240V	U.S. Toyo
Fan Motor 1 HP & 20HP	Siemens
Actuator 24V & 120V	Siemens
Power Distribution & MSP Enclosure (6"x24"x24")	Hoffman
Damper HD6 (8"x100"x120")	Huntair
Damper CD50 (8"x100"x120")	Ruskin
Actuator: 24V mo. AF24-MFT	Belimo

Line Drawings:

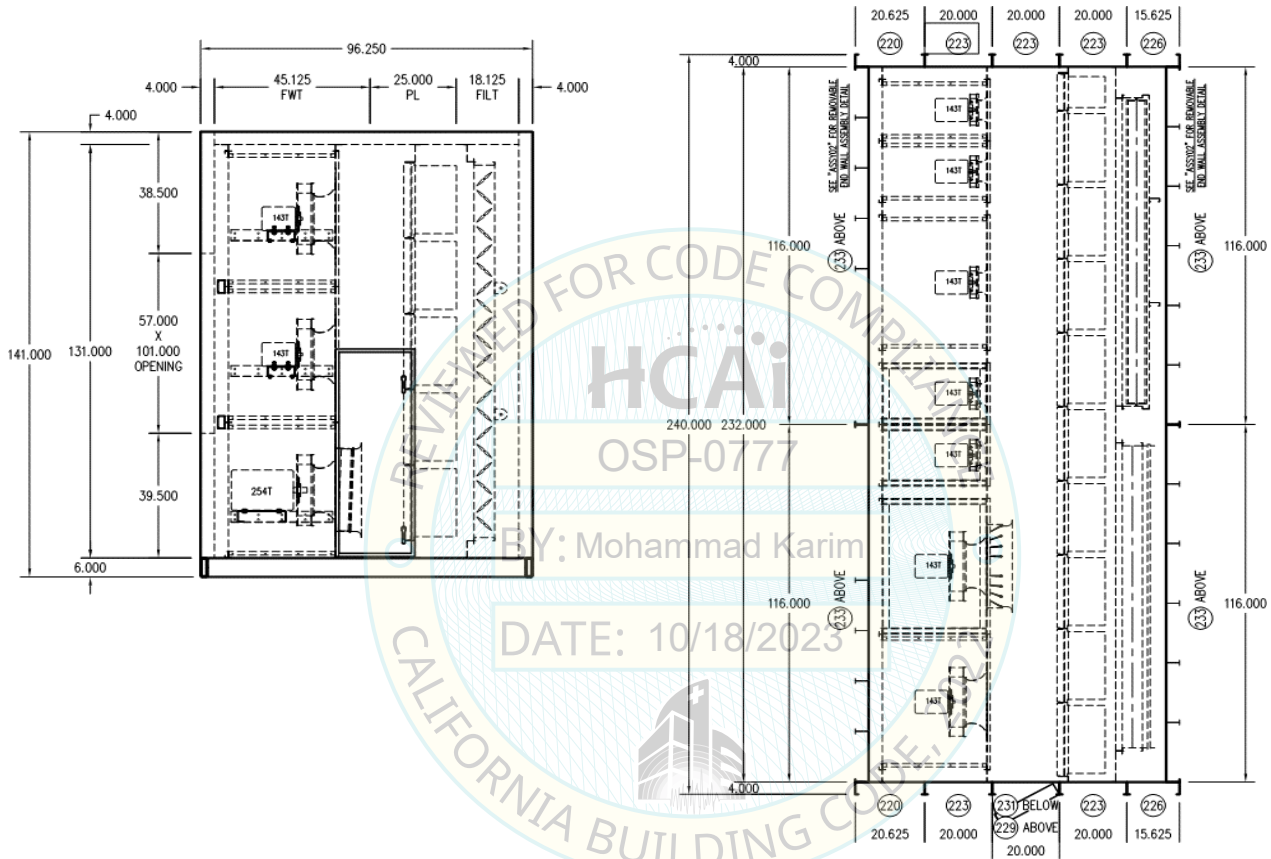

UUT 4

Test Report# 1700754-TR-001 R1

Manufacturer: Nortek Air Solutions, LLC
Model Line: Huntair Stack Air Handling Units
Model Number: CSU-20K STM/DX
Serial Number: 0120-01

Highest Passed Test Level						
S _{DS}	z/h	I _p	A _{flx-h}	A _{rig-h}	A _{flx-v}	A _{rig-v}
2.0	1	1.5	3.2	2.4	1.67	0.67
2.5	0					

Dimensions/Weights			
Depth (in)	Width (in)	Height (in)	Weight (lbs.)
138	244	160	27,535

Lowest Natural Frequency (Hz)		
Front-Back	Side-Side	Vertical
7.3	6.0	13.1

Building Codes
CBC 2022

Test Criteria
ICC-ES AC156

Construction/Option Summary
 Wall: 4" Panels 4 Variations - (A) 16 ga. stainless steel wall with 0.040" aluminum perforated liner, (B) 16 ga. galv carbon steel wall with 20 ga. galv. carbon steel solid liner, (C) 16 ga. stainless steel wall with 20 ga. stainless steel solid liner, (D) 16 ga. galv. carbon steel wall with 22 ga. stainless steel perforated liner, Roof: inner - 16 ga. stainless steel, outer - 16 ga. galv. carbon steel, sloped roof. Base: 12" tall stainless structural tubing, 12 ga. galv. carbon steel skin with 16 ga. galv. carbon steel liner and 16 ga. carbon steel subfloor.
 UUT: 104 psf

UUT Mounting Details: List of Included Subcomponents



All test units contain an integrated structural base frame. This unit was mounted directly to the seismic table using twelve (12) 5/8" - SAE grade 8 hex head bolts with flat washers and lock washers. Unit maintained structural integrity and remained operational per manufacturer requirement following shake table test. All contents were included in the unit per operating conditions.

Description	Manufacturer
Louver: AML6 (6"x36"x60")	Ruskin
Louver: AML3 (3"x100"x120")	Ruskin
Smoke Damper:SD50 (5"x33"x57")	Ruskin
Smoke Damper:SD50 (5"x96"x120")	Ruskin
Damper: AMS50 (15"x24"x36")	Ruskin
Damper: AMS50 (15"x48"x96")	Ruskin
LouverL EME (6" x 12" x 20")	Ruskin
LouverL EME (3" x 100" x 120")	Ruskin
Fan Wheel/Motor Combo Size 12 and Size 22	Nortek Air Solutions
Fan Motor: 1 HP and 15 HP	Toshiba
Fan Motor: 2.5kW and 6kW	Nortek Air Solutions
UV Lights: RLM Xstream 33 and 61	UV Resources
UV Lights: DEF 220 and DEF 340	UV Resources
DX Coil Evap. (8.5"x 150"x45")	Nortek Air Solutions
DX Coil Evap. (8.5"x56"x45")	Nortek Air Solutions
DX Coil Evap. (8.5"x 150"x45")	Heatcraft/Modine
DX Coil Evap. (8.5"x56"x45")	Heatcraft/Modine
Fan Wheel: Gen II 12" (2 wide x 4 high, multistack & adjacent cell)	Huntair
Two Fan Wheel: Gen II 22" (2 wide x 4 high, multistack & adjacent cell 1. 38"x40"x44" 2. 33"x44"x44")	Huntair
Control and VFD Enclosure (10"x 28"x 40" and 16"x 56 x 90")	Huntair
Actuator AF120	Belimo
Actuator MS4120F	Honeywell
VFD: FC1001 (1HP & 15HP), VLT (5HP & 100HP)	Danfoss

UUT 4

Test Report# 1700754-TR-001 R1

Line Drawings:

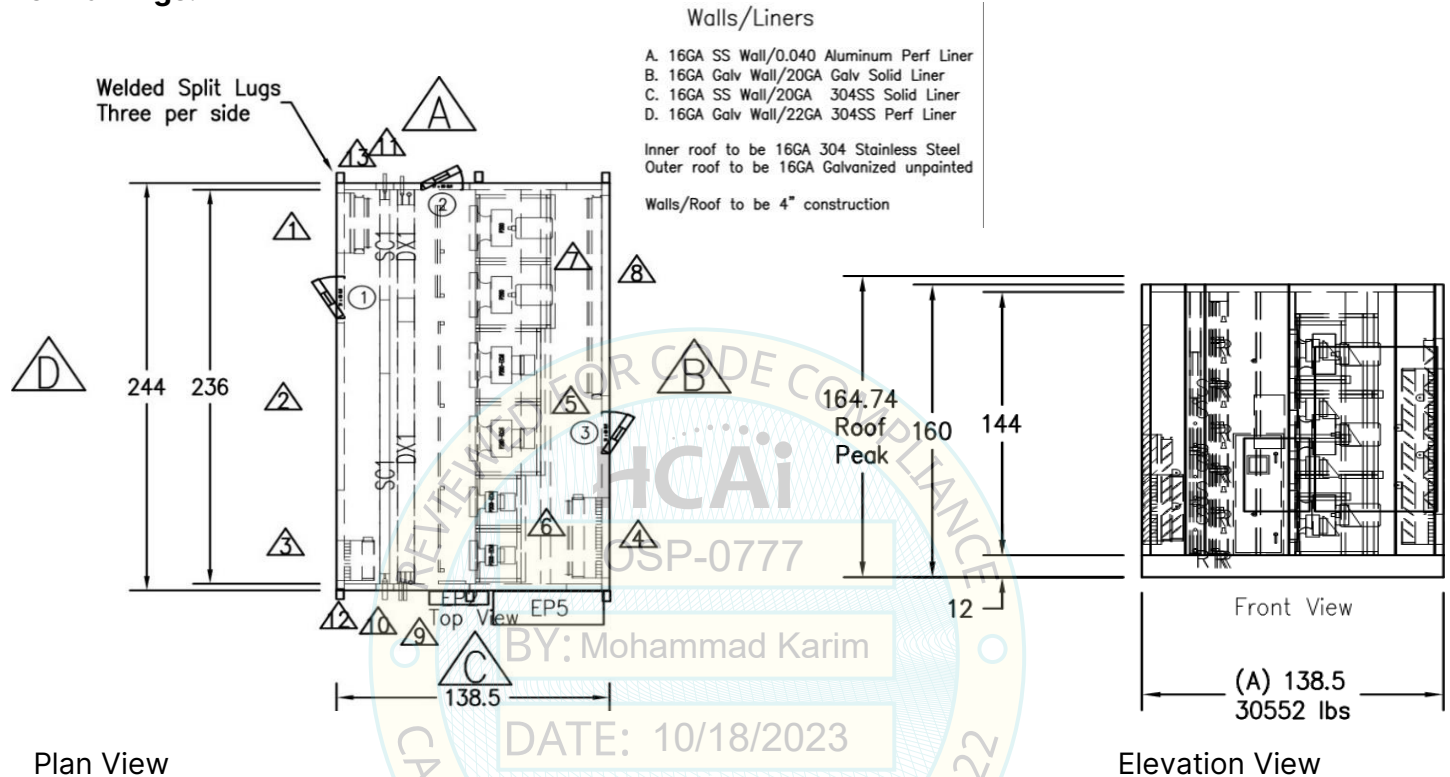

Plan View

Elevation View

Seismic Upgrade Implemented:

UUT 4 seismic upgrades consisted of mounting (3) 12GA 8"x8" stainless steel brackets to the wall and coil rack using (6) #10-3/4" self tapping screws. Two were mounted to the rear fo the unit and one was mounted to the front of the unit above the door.

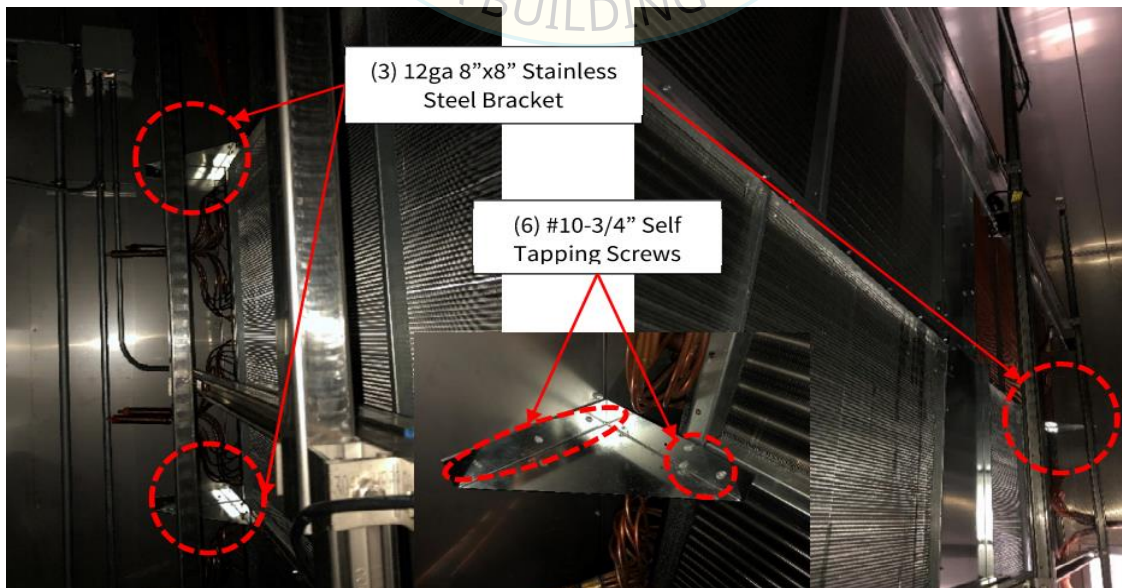

Line Drawings:

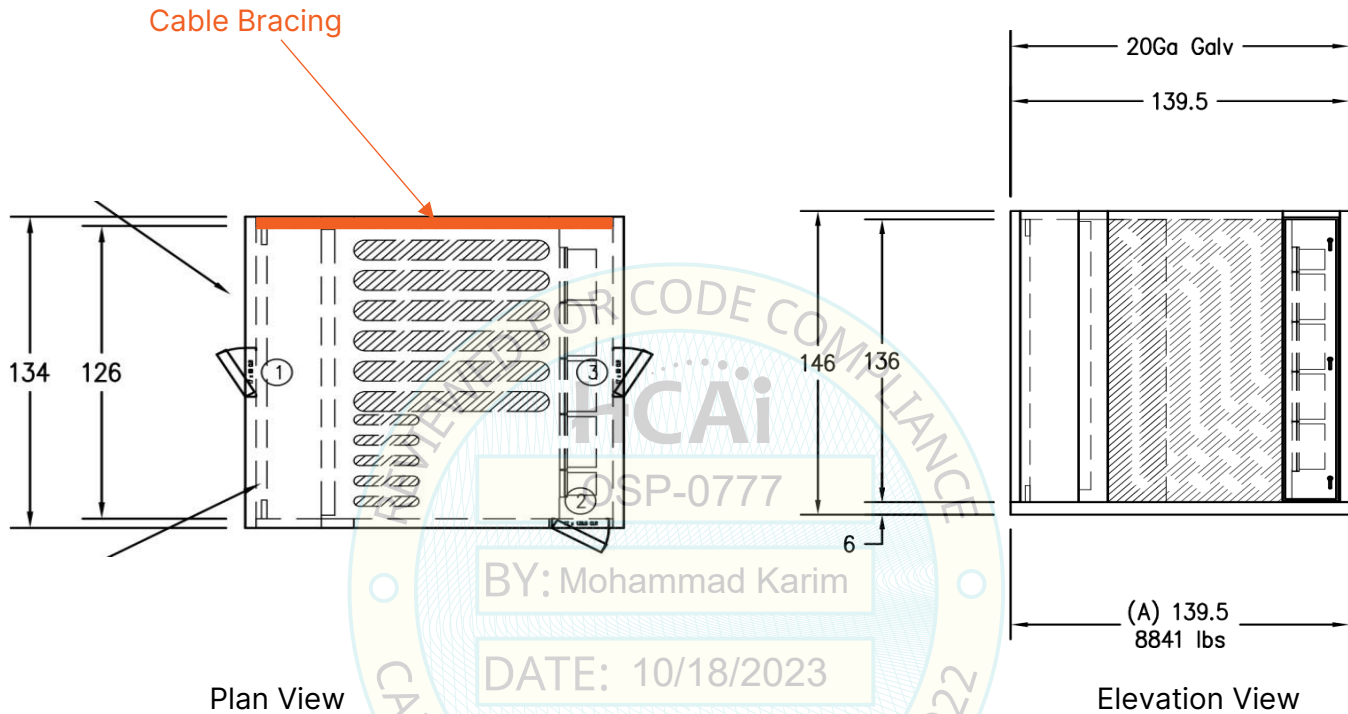

Seismic Upgrade Implemented:

Attachment of the the humidifier grid: 1-5/8" 12ga unistrut member was attached to the ceiling with #12-3/4" self tapping screws at 8" O.C. The unistrut member was attached to the vertical humidifier supports via 3/8"f stainless steel thru bolts. (2) 3"x3" L-shaped blankoffs were added to the vertical unistrut supports and wall panels. Blankoffs were attached to the vertical unistrut via 3/8"f stainless steel thru bolts at 24" O.C., and to the wall panel with #12-3/4" self tapping screws at 6" O.C.



UUT 5

Test Report# 1700754-TR-001 R1

Seismic Upgrade Implemented:

Bearing support of humidifier grid: (1) 16GA stainless steel 2"x 4" channel that was cut to length to bear against the base structure and the bottom of the humidifier header tube. The channel was mounted to the floor using (4) #14-3/4" self tapping screws and (2) 1"x 1/2" 12GA stainless steel L-brackets.



Additional Lateral Bracking: (2) 3/8" stainless steel braces fastened with (16) #12-3/4" self tapping screws per 12GA stainless steel mounting bracket.



Additional Images:

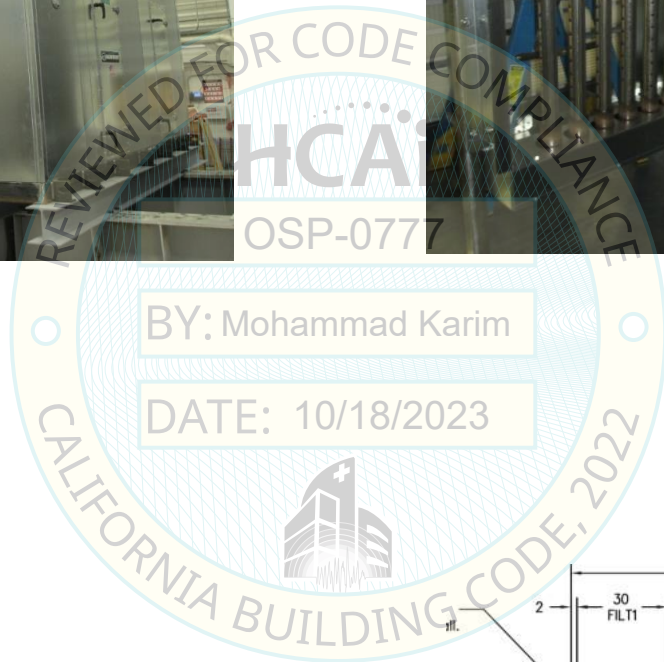
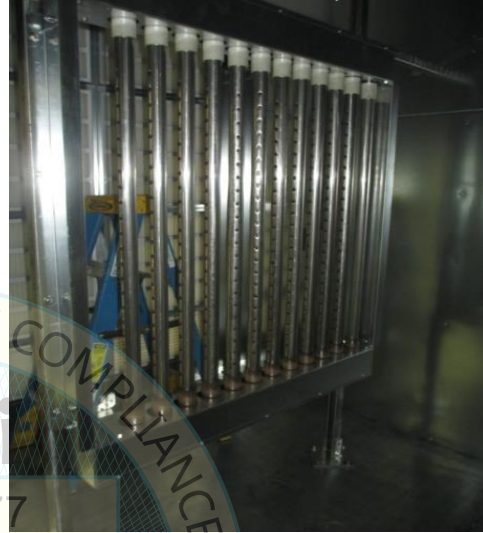

Line Drawings:

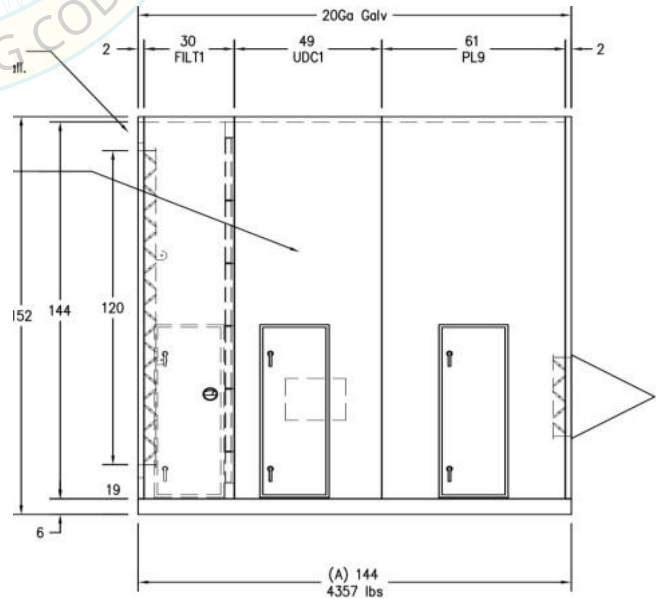
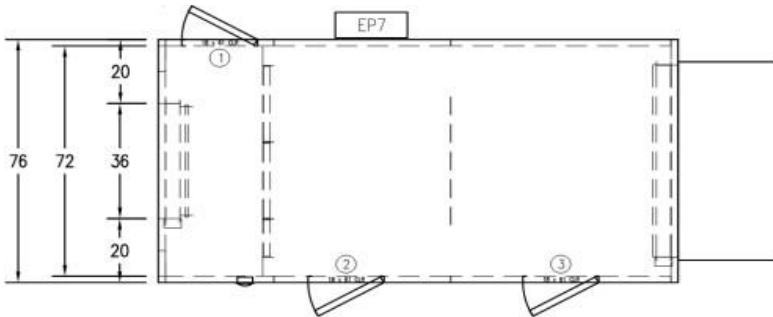

Plan View

Elevation View

UUT 6a

Test Report# 1700754-TR-001 R1

Modifications made due to shipping damage:

UUT 6 was damaged during shipping. It was discovered that during the fabrication of this unit, the fasteners did not extend into the cabinet panel structure.

Implemented repair: #12-3" self tapping screws @12" OC were fastened from the outside of the unit, attaching the flange of the structural channel along the entire perimeter of the OAFE-1550 casing. The original fasteners were removed. Modification is already a part of the fabrication process.



Seismic Upgrade Implemented:

Seismic upgrade for UUT6A consisted of mounting a 1-5/8" stainless steel 12GA Unistrut (P1000) cut to the width of the unit mounted to the wall and vertical Unistrut support of the humidifier. The wall and Unistrut interface connection consisted of a 3/8" stainless steel bolt and 1/4" stainless steel Unistrut L-bracket (P1026), while the Unistrut to Unistrut connection consisted of a 3/8" stainless steel bolt, strut nut, and 1/4" Unistrut L-bracket (P1026).

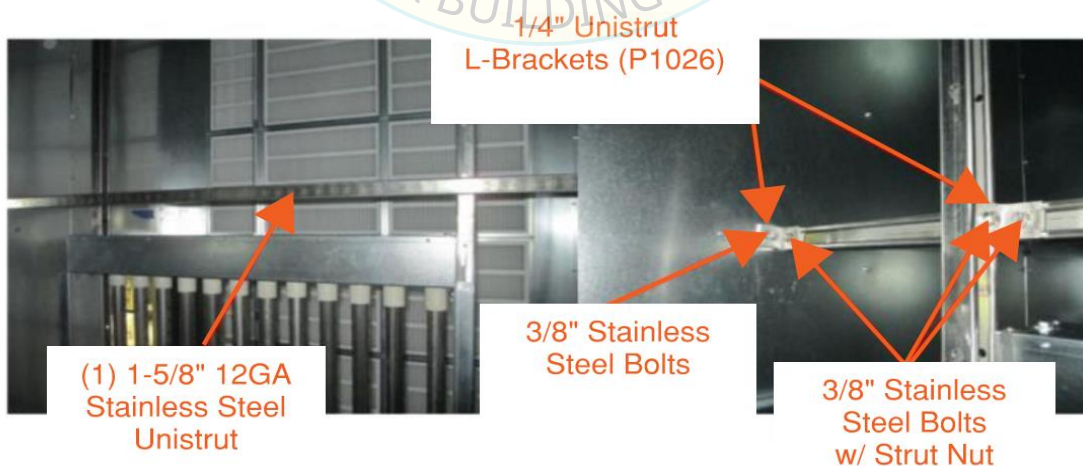

UUT 6b

Test Report# 1700754-TR-001 R1

Additional Images:

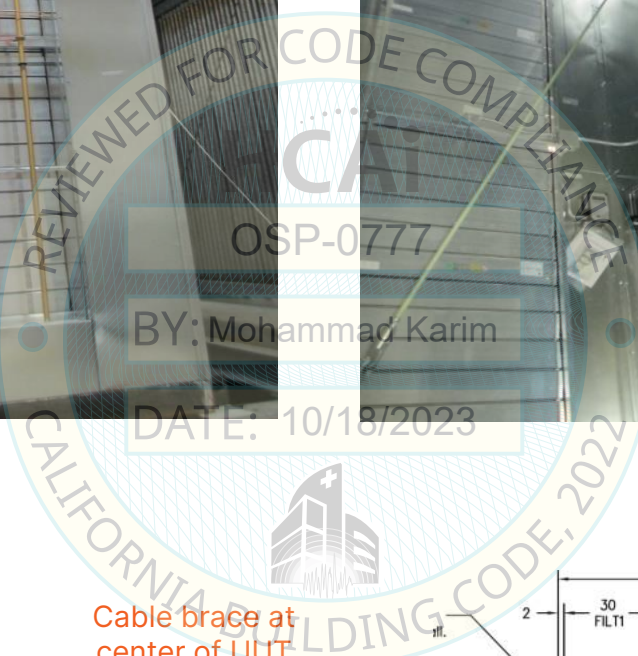

Line Drawings:

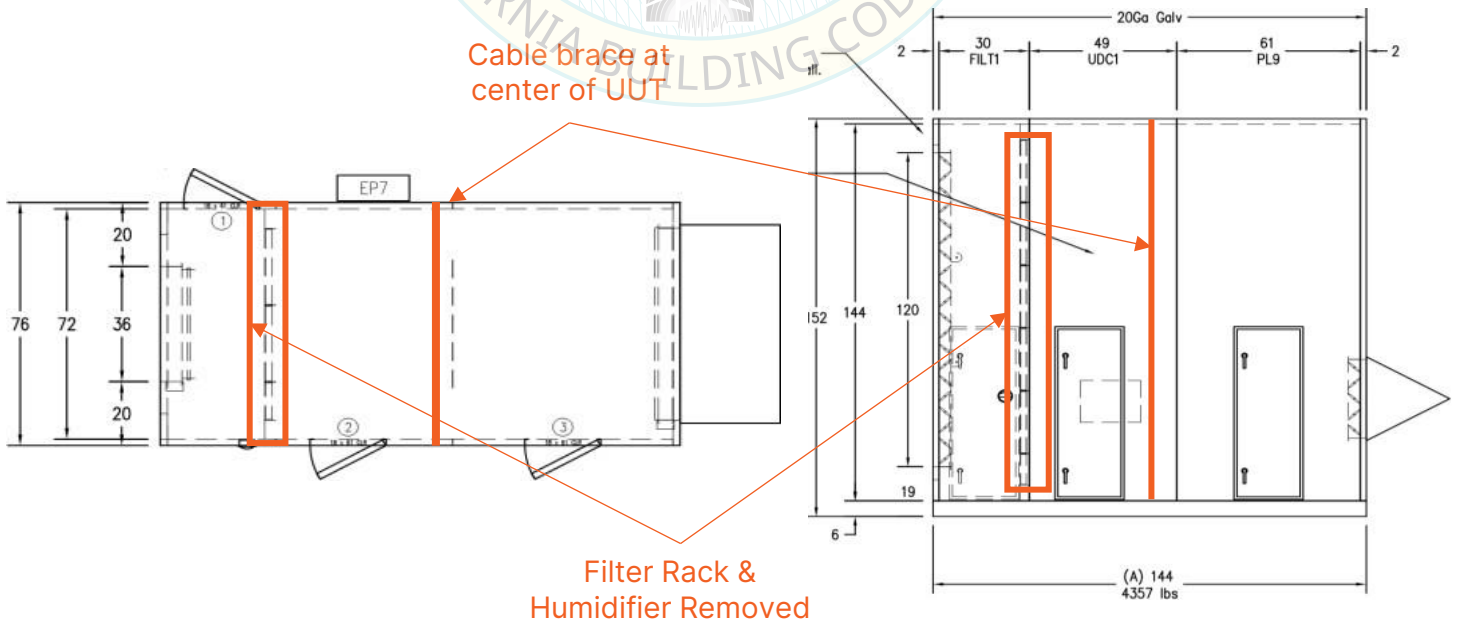

Plan View

Elevation View

UUT 6b

Test Report# 1700754-TR-001 R1

Modifications made due to shipping damage:

UUT 6 was damaged during shipping. It was discovered that during the fabrication of this unit, the fasteners did not extend into the cabinet panel structure.

Implemeted repair: #12-3" self tapping screws @12" OC were fastened from the outside of the unit, attaching the flange of the structural channel along the entire perimeter of the OAFE-1550 casing. The original fasteners were the removed. Modification is already a part of the fabrication process.



Modified repair:

#12-2" self tapping screws were drilled from the inside of the unit around the entire perimeter of the OAFE-1550 casing at 12" OC. The previous fastners were removed.



UUT 6b

Test Report# 1700754-TR-001 R1

Seismic Upgrade Implemented:

Seismic upgrade for UUT6A consisted of mounting a 1-5/8" stainless steel 12GA. Unistrut (P1000) cut to the width of the unit mounted to the wall and vertical Unistrut support of the humidifier. The wall and Unistrut interface connection consisted of a 3/8" stainless steel bolt and 1/4" stainless steel Unistrut L-bracket (P1026), while the Unistrut to Unistrut connection consisted of a 3/8" stainless steel bolt, strut nut, and 1/4" Unistrut L-bracket (P1026).

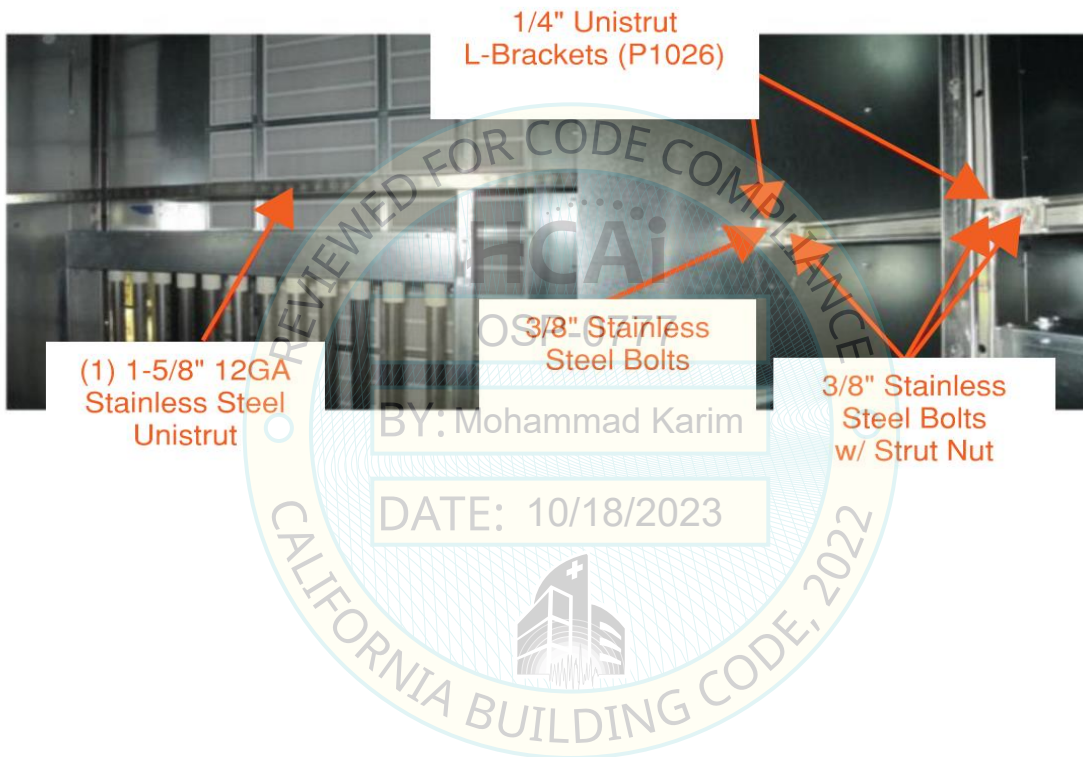

UUT 7

Test Report# 13379 Rev.1

Additional Images:



Unit Drawings:

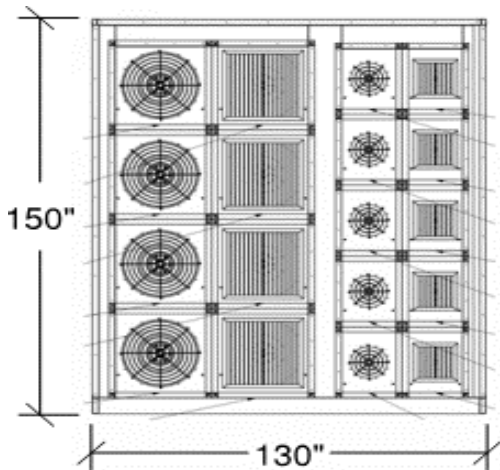

Elevation View

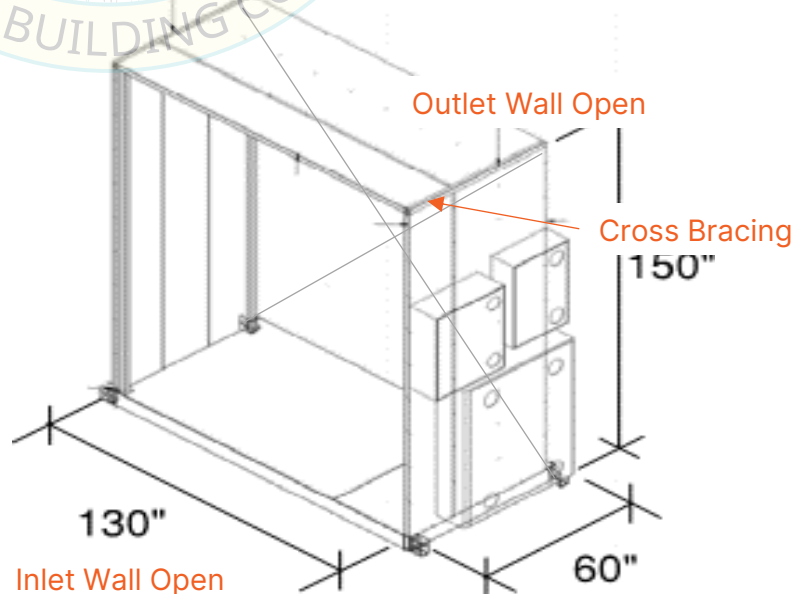

Outlet Wall Open

Cross Bracing

Inlet Wall Open

Isometric View

UUT 8

Test Report# 13379 Rev.1

Unit Drawings:

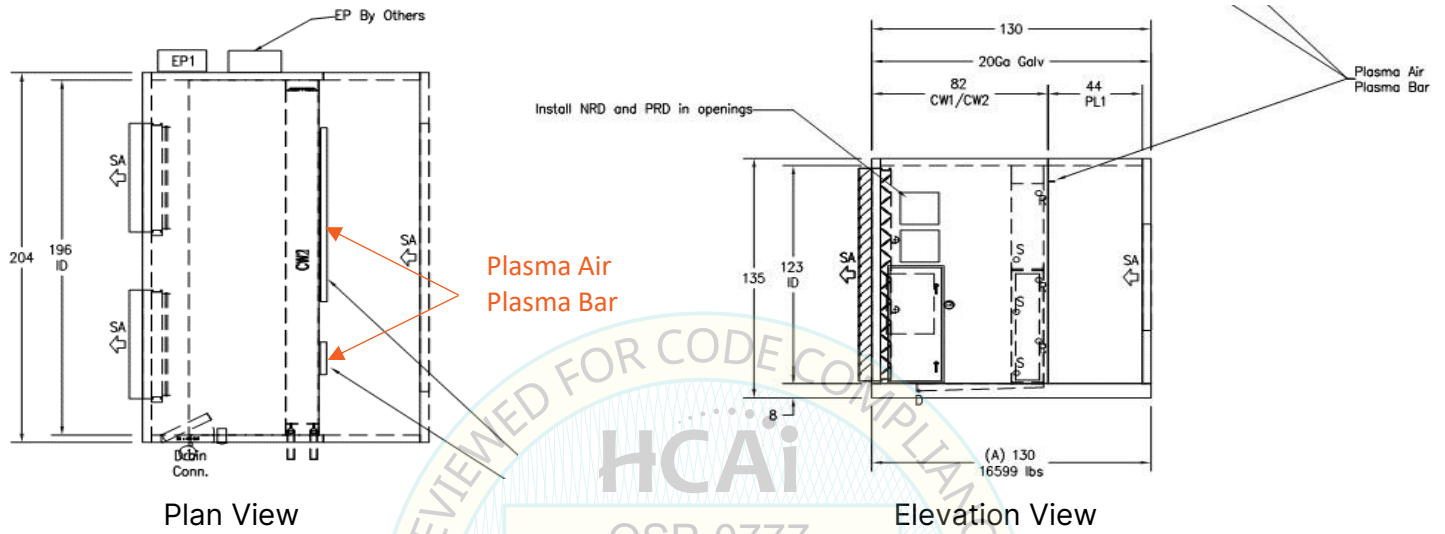

Seismic Upgrades Implemented (required for large coil as defined in table 5):

(1) 1/4" -14 screws top and bottom of coil at 10" O.C. max spacing, (2) 2-12ga. c-channel stiffeners¹ each side of coil, (3) 1/4"-14 screws at 10" O.C. max spacing along each c-channel stiffener.

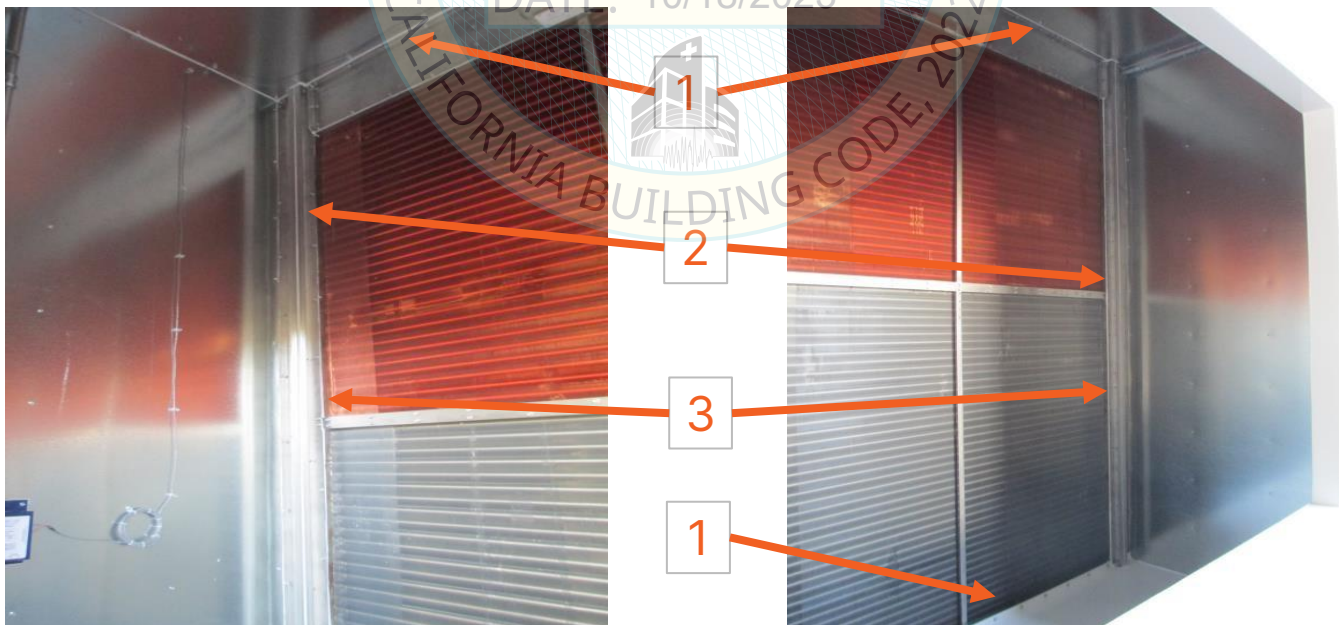

Note:

¹Stainless steel c-channel tested, stiffener channel may also be constructed of carbon steel.

UUT 9

Test Report# 1700975-TR-001 R0

Manufacturer: Nortek Air Solutions, LLC
Model Line: Huntair Stack Air Handling Units
Model Number: CSU-6K CHW
Serial Number: N/A

Highest Passed Test Level						
S _{DS}	z/h	I _p	A _{flx-h}	A _{rig-h}	A _{flx-v}	A _{rig-v}
1.37	1	1.5	2.19	1.64	0.91	0.37

Dimensions/Weights			
Depth (in)	Width (in)	Height (in)	Weight (lbs.)
84	222	88	9,943

Lowest Natural Frequency (Hz)		
Front-Back	Side-Side	Vertical
15.48	14.72	31.16

Building Codes
CBC 2022

Test Criteria
ICC-ES AC156

Construction/Option Summary
 Cabinet Material 16GA Galv (12 GA Galv for lower tunnel for support). Solid Liner: Fiberglass Std - Unfaced (R8), Base Construction: Steel tube, base floor: 12 GA Galv, sub floor: 20 GA Galv., Insulation: Polyurethane Foam
 UUT Upper: 48 psf, Lower: 54 psf

UUT Mounting Details:



The unit was mounted to the test fixture using ten (10) 5/8" SAE grade 8 hex head bolts with flat washers and washers. Unit maintained structural integrity and remained operational per manufacturer requirement following shake table test. All contents were included in the unit per operating conditions.

List of Included Subcomponents

Description	Manufacturer
CD 50 (5" x 19.5" x 24")	Ruskin
CD 50 (5" x 24" x 30")	Ruskin
VFD (ACH550 Series) 15 HP	ABB
VFD (ACH550 Series) 7.5 HP	ABB
Humidifier Grid: Ultra Sorb LV (51" x 33")	DriSteem
Heat Transfer Coil: Huntair, 11 FPI, 5 row, copper, stacked mounting - qty. 2 (79.25"x8.75"x33")	Nortek Air Solutions
4 HP, 460V Motor	Toshiba
Fan Wheel: Gen II 12" (3 wide x 1 high, multistack & adjacent cell)	Huntair
Fan Wheel: Gen II 14" (3 wide x 1 high, multistack & adjacent cell)	Huntair
Filter Frame: Type 8 (2.69" x 36" x72.1")	Camfil, AAF, Huntair, Farr

UUT 9

Test Report# 1700975-TR-001 R0

Unit Drawings:

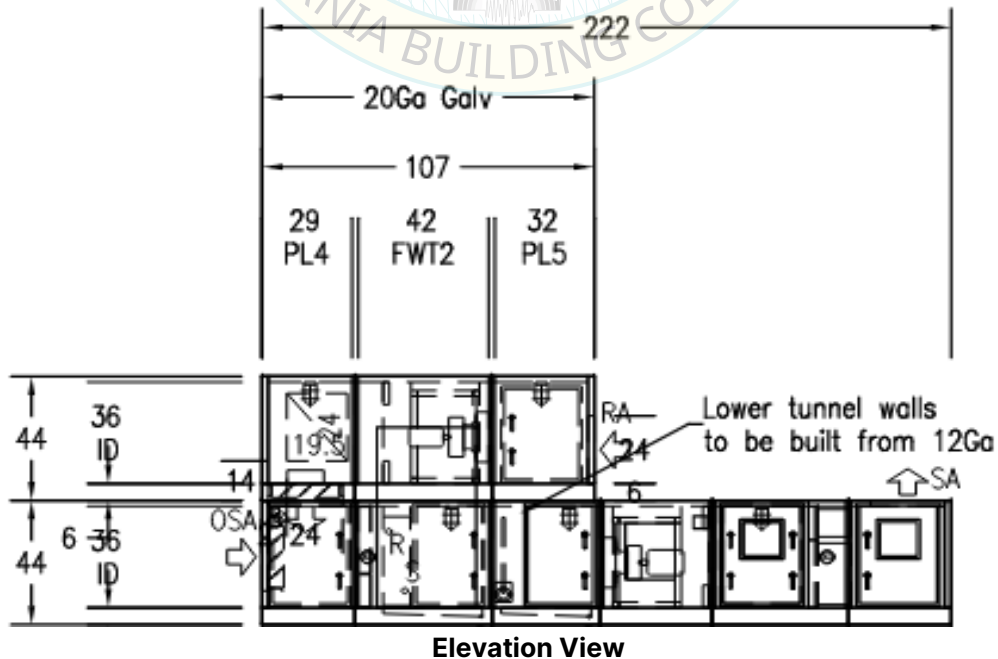
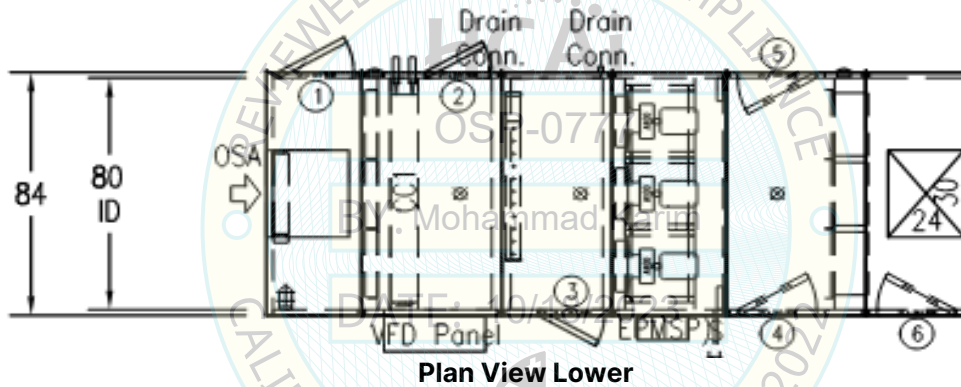
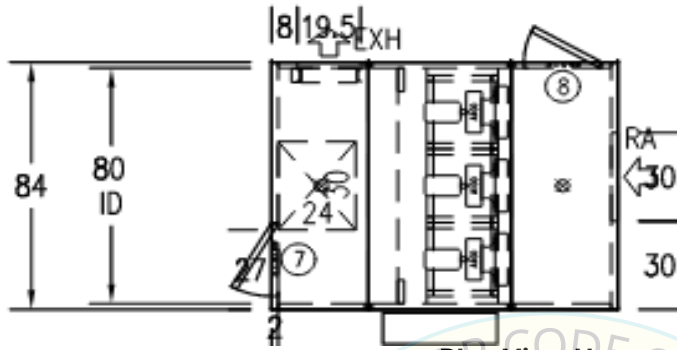

Additional Mounting Images:



Unit Drawings:

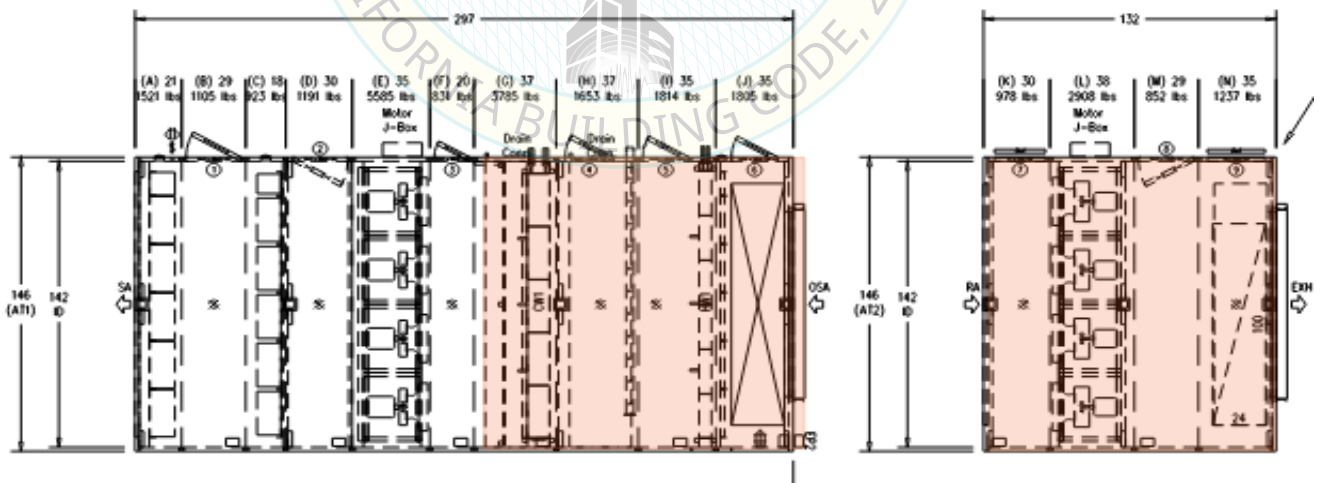

Plan View
UUT 10 Highlighted Section

Unit Drawings:

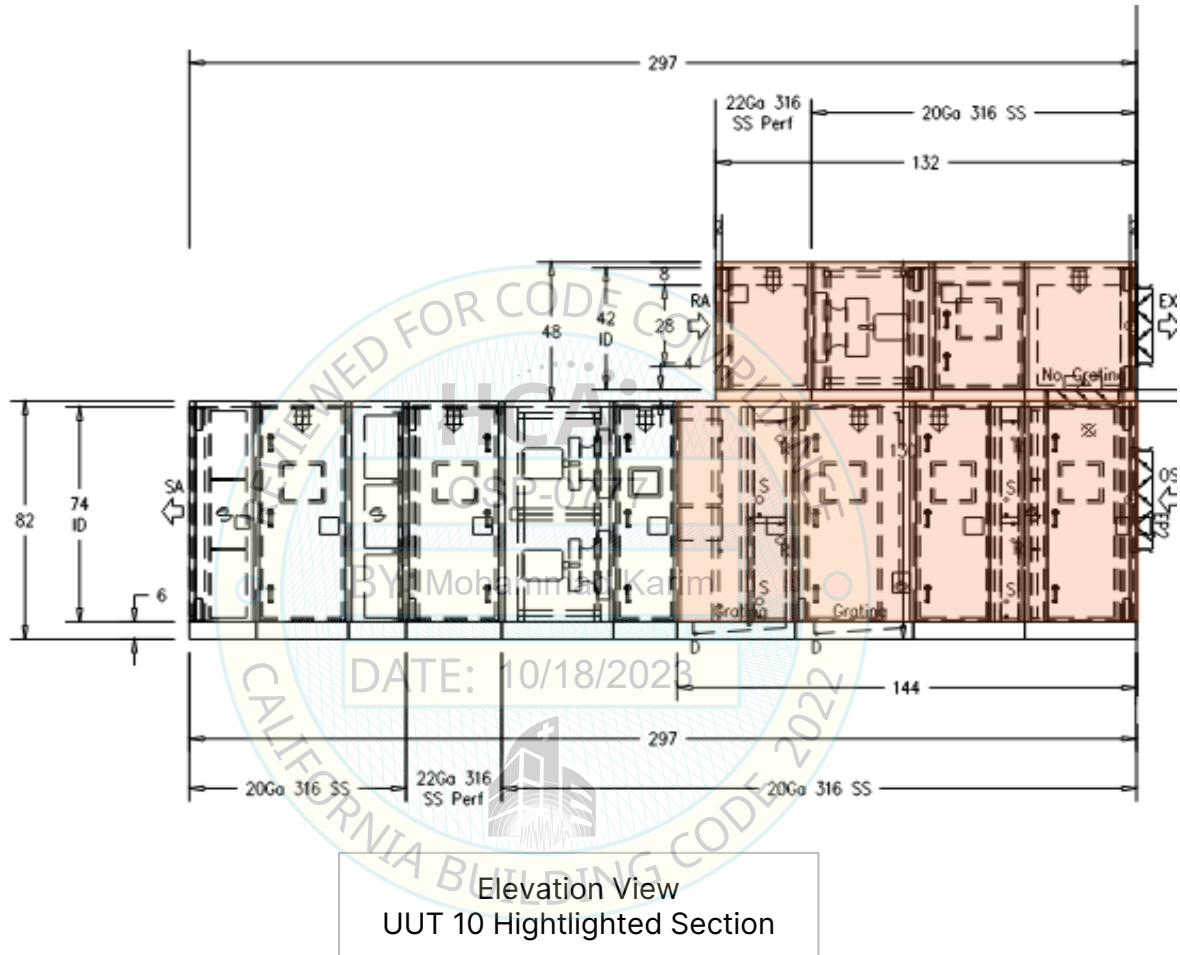

- ① FANWALL
- ② Coils
- ③ Pre/Final Filters
- ④ UV LIGHTS
- ⑤ Humidifier
- ⑥ Damper
- ⑦ Electrical Panel (SF J-Box)
- ⑧ Electrical Panel (RF J-Box)
- ⑨ SEISMIC BRACE
- ⑩ Access Door

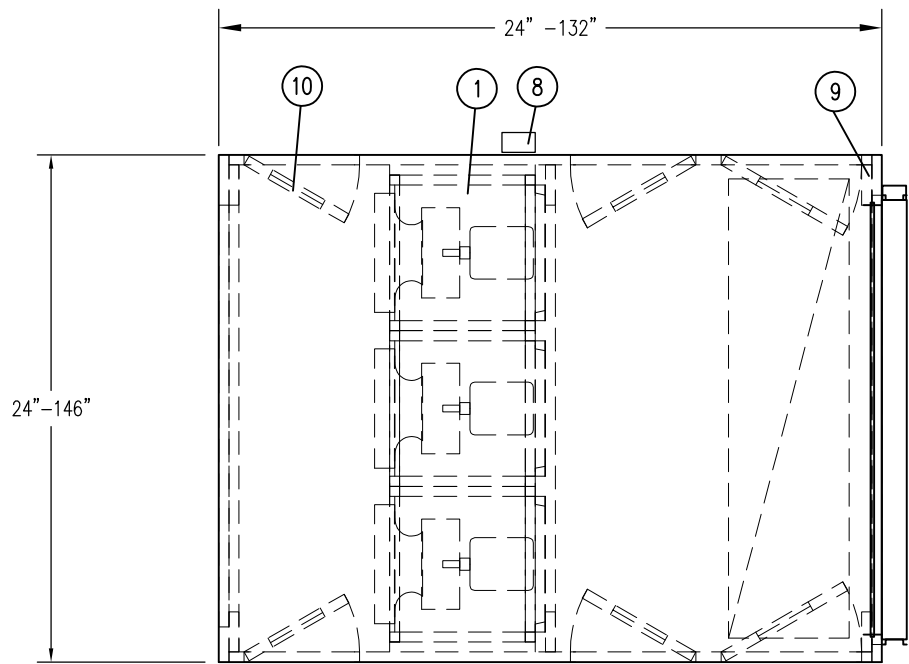

Plan View Upper Tunnel

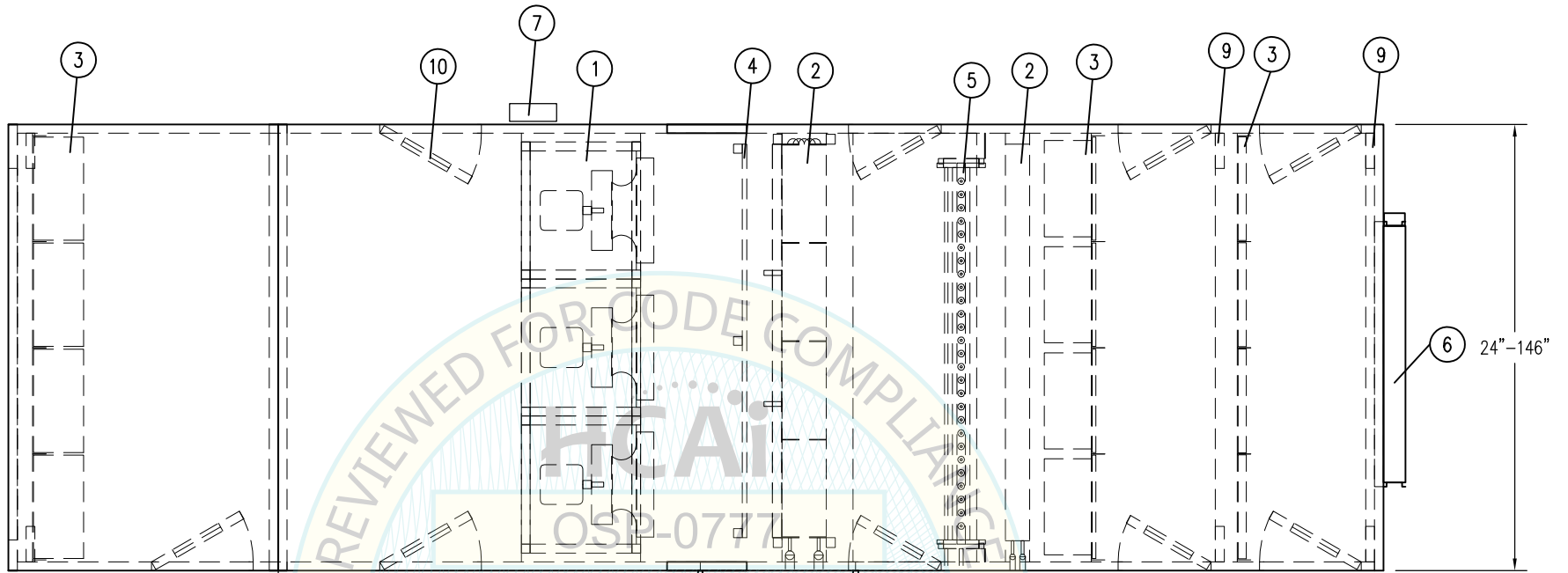

BY: Mohammad Karim
Plan View Lower Tunnel

DATE: 10/18/2023

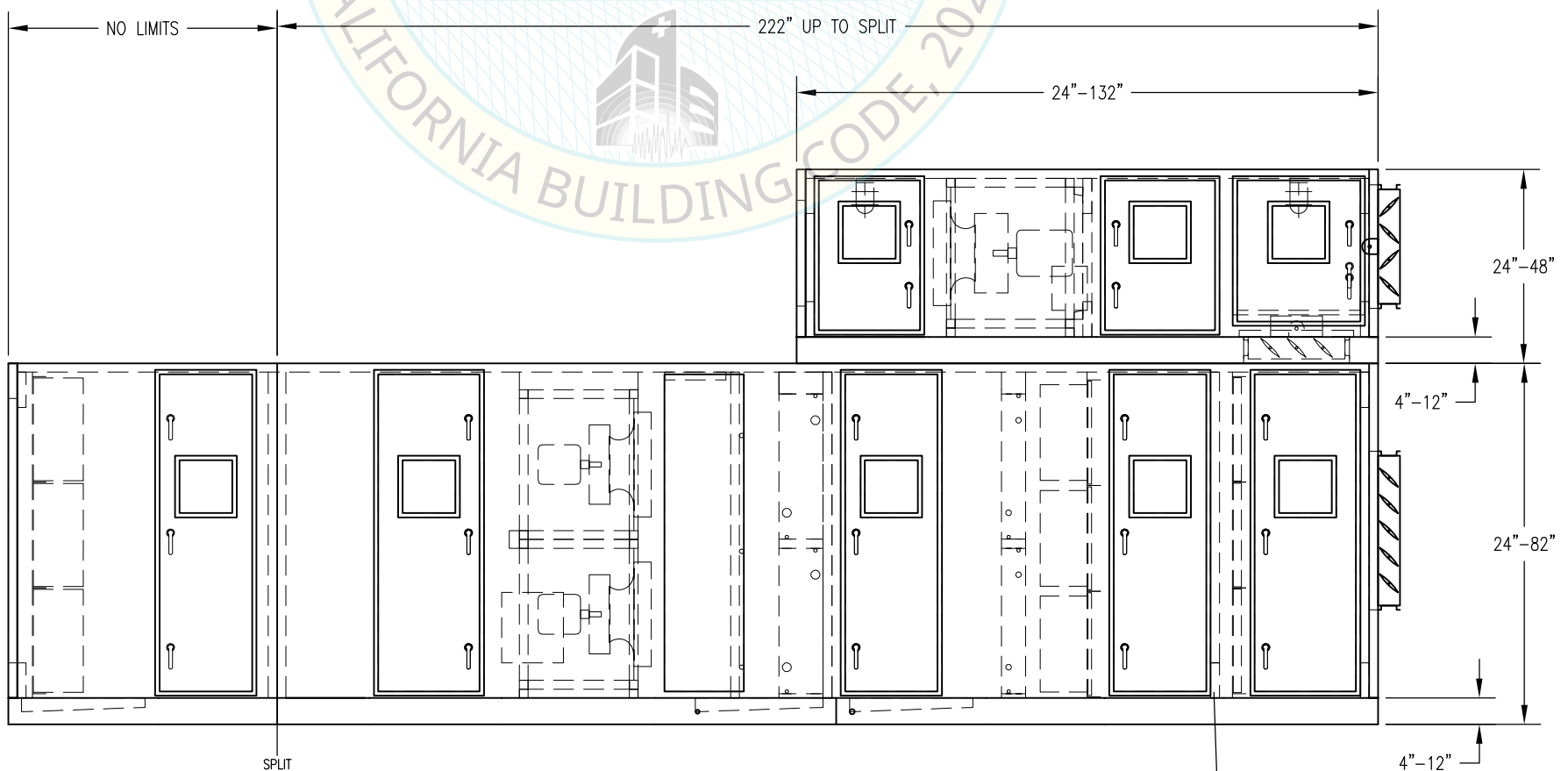

Side View

For Interior Seismic Brace requirements and spacing see OSHPD Seismic Brace detail.

Construction Notes:

1. All dimensions are in inches unless stated otherwise.
2. Insulation thickness/panel size: 2" and 4".
3. Cabinet Material: carbon steel, 16ga (top) 12-16ga (bottom).
4. Base can be structural tube (4" to 12" height).
5. Interior seismic bracing to be implemented for upper and lower sections per restrictions detailed on sheet "OSHPD BRACE DETAILS".
6. Base frame must be anchored along sides but need not be anchored at ends.
7. All splits shall maintain structural continuity between sections.
8. All traverse base members to be designed for tributary dead load and full capacity of seismic braced frame elements.
9. Overall height/width aspect ratio shall not exceed 1.0.

10/18/2023

OSP-0777



19855 SW 124th Ave. (503) 639-0113
Tualatin, OR 97062 www.nortekair.com

This document is confidential, copyrighted and property of Nortek Air Solutions, LLC and may not be reproduced or used in any fashion without prior written permission. To view patents and other pending U.S. or Canadian patent applications visit NortekAir.com/Patents

A	Added split made changes to dimensioning as suggested	10/12/23
Rev	Revision Description	Date m/d/y
SEISMIC STACKED AHU		
Unit Tag		Unit Type Dsg Qty
Rep Firm		Weight Box Qty
Rep Contact		Model No
NASDA Ver	Factory SAE	Date m/d/y
Page 58 of 59	SF	9/14/23
		Rev A

Transverse Bracing Requirements:

1. Bracing required at 6'-0" maximum spacing. Spacing is calculated as the sum of distances between braces on each side of brace divided by 2.
2. Bracing elements for
 - a. Coil wall
 - b. Fanwall
 - c. Cable Brace
 - d. Panel Wall meeting the requirements listed below
3. Bracing elements Aspect Ratio > 1.1:
4. Bracing elements 2.a. through 2.c. and 3a must run the full width and height of the cabinet enclosure.
5. Humidifier Systems require independent structural support or adjacent upstream cable brace (see UUT-2b, 5, an 6A).

Panel Wall Bracing Requirements:

6. If a panel wall is utilized as a bracing element, the following conditions must be met:
 - a. The bracing wall must be of the construction detailed in the OSHPD approved drawing set.
 - b. Height to width ratio of the bracing wall must not exceed 2.0.
 - c. Openings in a bracing wall shall not exceed the lesser of one third of the height of the total bracing wall and one third the width of the total bracing wall.
 - d. Exterior openings are defined to be at an exterior wall of the cabinet enclosure.
 - e. Exterior bracing walls not meeting 4.c. criteria must have the total length of exterior wall be greater than or equal to the total length of the combined exterior openings on the exterior wall.
 - f. Exterior walls running perpendicular to air flow not meeting 4.c. or 4.e. criteria must have a supplementary bracing element placed within 3'-0".
 - g. Exterior walls running parallel to air flow not meeting 4.c. or 4.e. criteria are not allowed.

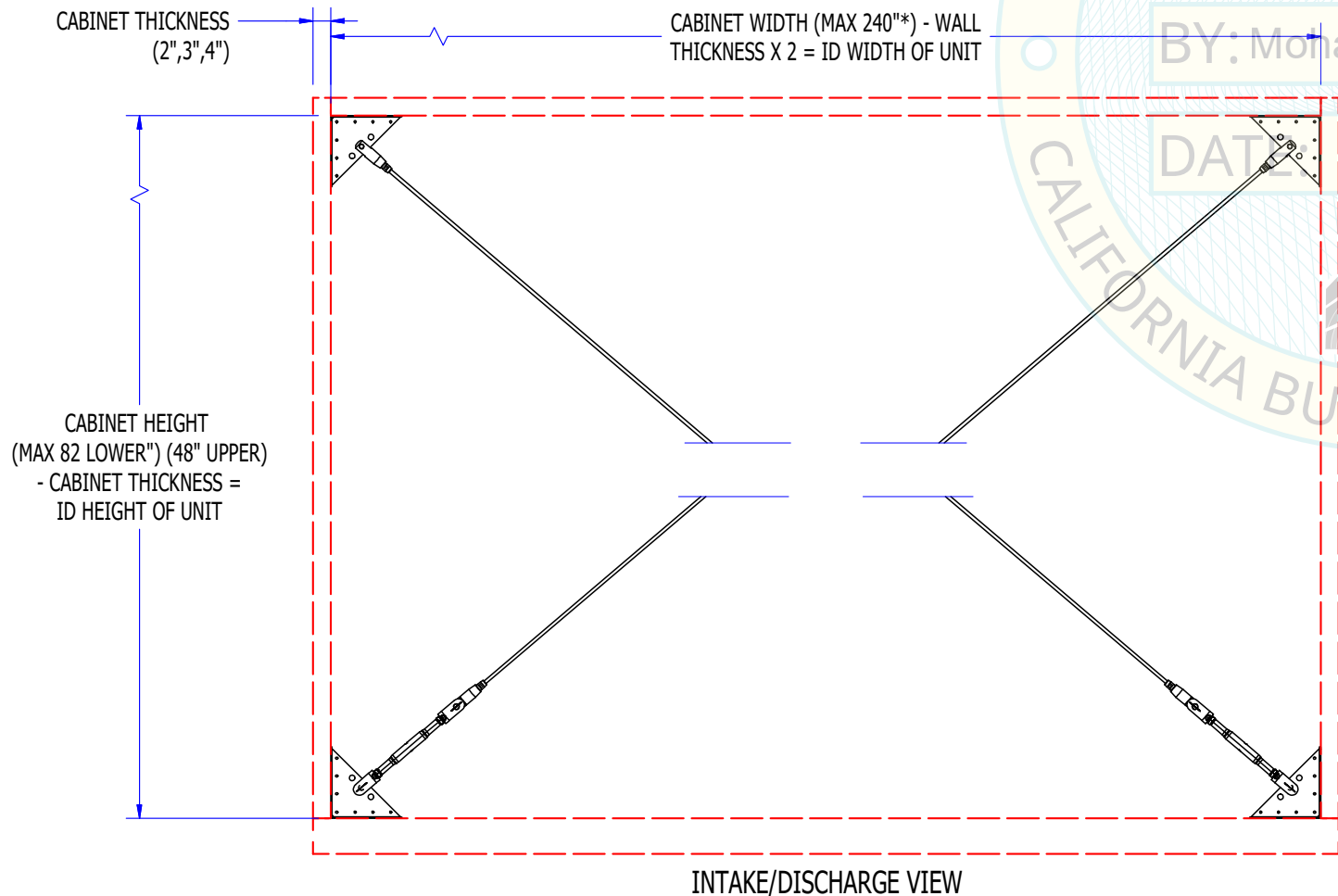
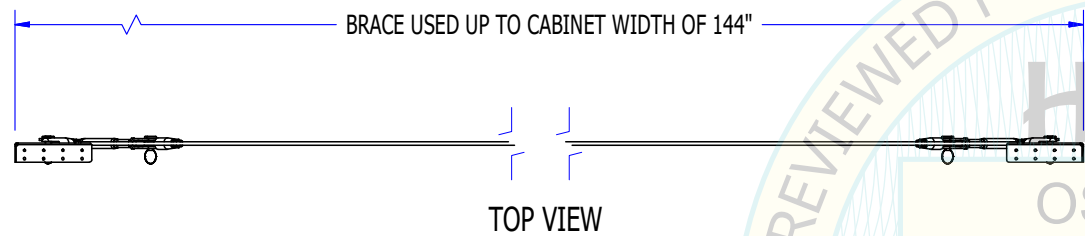

CABINET WIDTH IS DEFINED AS THE DIMENSION FROM EXTERNAL WALL TO OPPOSING EXTERNAL WALL IN THE DIRECTION PERPENDICULAR TO AIR FLOW.
10/18/2023

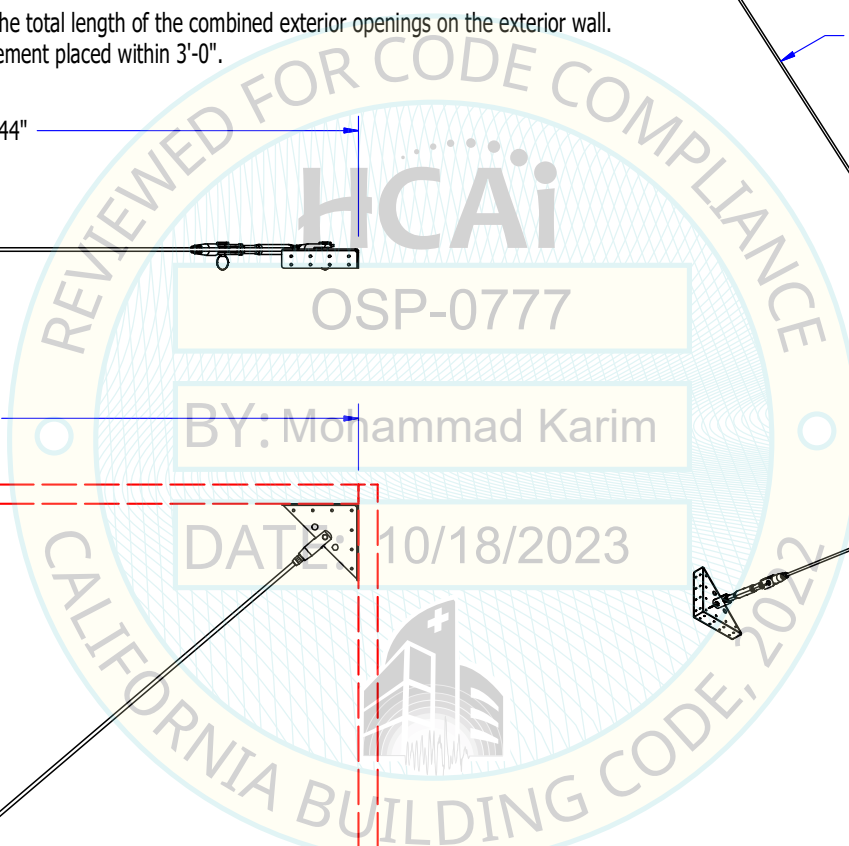
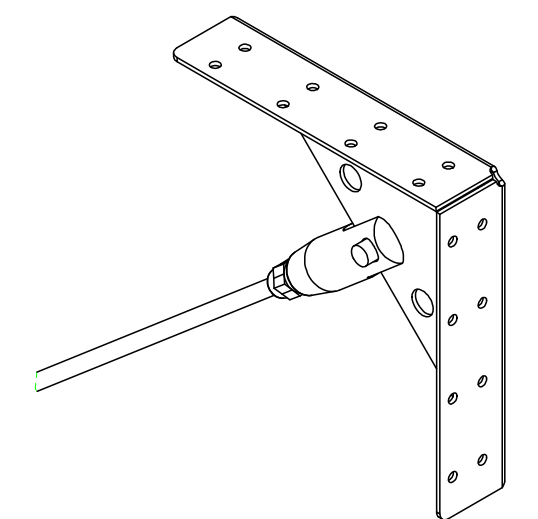
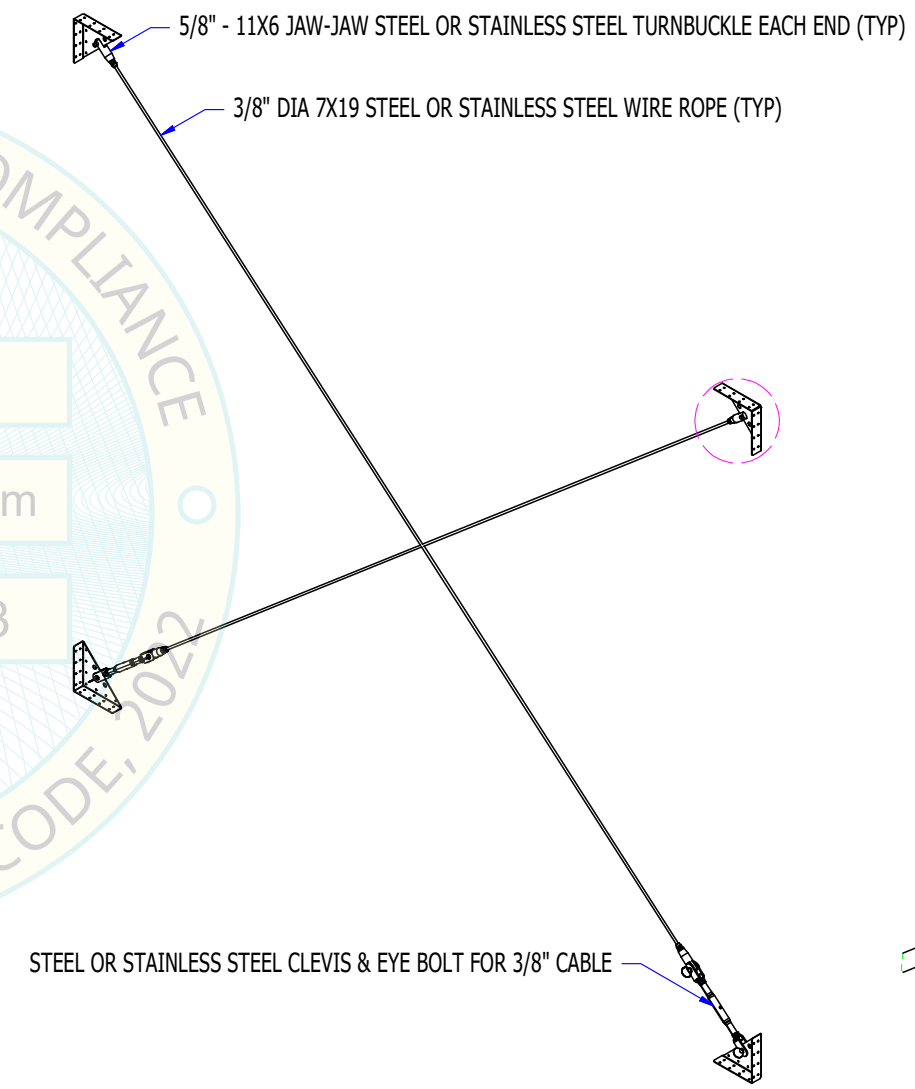
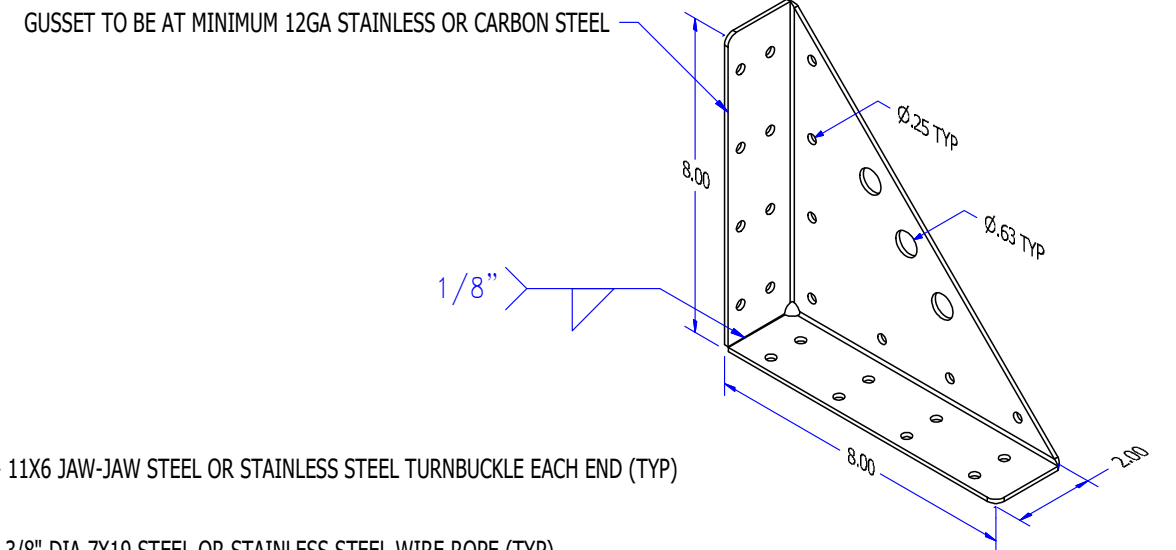

TOLERANCES UNLESS OTHERWISE SPECIFIED FRACTIONS: ±1/32 0.0: ±0.1 0.00: ±0.03 0.000: ±0.010 ANGLES: ±0.5° OTHER: SEE DOC. OMS000.01A	THIS DRAWING, SPECIFICATIONS, AND CONCEPTS CONTAINED HEREIN ARE THE SOLE PROPERTY OF CES GROUP, LLC, AND MAY NOT BE REPRODUCED OR USED IN ANY FASHION WITHOUT THE PRIOR WRITTEN PERMISSION OF CES GROUP, LLC.	DRAWN BY: M FARLEY		19855 SW 124th AVE. TUALATIN, OR 97062 Phone (503) 639-0113 Fax (503) 692-0958
		ISSUED ON: 10/12/2023		
		CHECKED BY:	FILE NAME:	REV:
		PART NO.:	STACKED UNIT OSHPD BRACE DETAILS OSHPD CABLE BRACE CABLE BRACE DETAILS	
OSP-0777				Page 59 of 59 1 OF 1