

HCAI



EXPEDITED BUILDING PERMIT FOR INSTALLING A CONNECTION FOR A TEMPORARY GENERATOR – FULL BUILDING BACKUP

6

How -To Guide Series

FOR SINGLE STORY WOOD OR LIGHT STEEL FRAME CONSTRUCTION SKILLED NURSING FACILITIES & INTERMEDIATE CARE FACILITIES (OSHPD 2 Buildings)

A Companion Document to the FREER Manual

October 2021 Hardcopy Version

EXPEDITED BUILDING PERMIT GUIDE FOR INSTALLING A CONNECTION FOR A TEMPORARY GENERATOR FULL BUILDING BACKUP

The Expedited Building Permit Guides are companion documents to the Department of Health Care Access and Information (HCAI) Field Review, Exempt, and Expedited Review (FREER) Manual and are intended as general reference guides and/or checklists to facilitate **repair, maintenance, minor renovation/remodeling, or installation of certain equipment** projects.

The Expedited Building Permit Guides are intended only for single-story Skilled Nursing Facilities (SNFs) and Intermediate-Care Facilities that are of wood frame construction or light steel frame construction and excluded from the definition of “Hospital Building” in the California Administrative Code (CAC) Article 2, Section 7-111.

This Expedited Building Permit Guide is made available for use at the discretion of the facility owner. HCAI (Department) does not mandate the use of the Expedited Building Permit Guide for any condition. Use of project-specific design and construction documents prepared by a California licensed design professional in lieu of using the Expedited Building Permit Guide is always acceptable, and in some cases, may be required.

This Expedited Building Permit Guide gives no consideration to suitability for use in a specific application, compatibility with other building systems, appropriate use of materials or design, appearances, etc. The facility owner and/or his/her representative shall review all such qualities, features, and/or properties to ensure compliance with the California Building Standards Code and all applicable local codes and ordinances, appropriate integration with other building systems, and proper design for the project specific conditions and installation, etc. This shall include pre-assessment for existing damage that may need to be repaired and/or corrected.

While not mandatory, HCAI recommends the facility have a California licensed architect or engineer, or a California licensed contractor assist in the review of the code compliance checklist herein below. In this manner, the facility will have a better understanding of the scope of work that may be required for a code compliant project prior to beginning the work.

The following regulations of the California Building Standards Code apply:

Before commencing construction or alteration of any health facility, the governing board or authority thereof shall submit an application for plan review to the Department, and shall obtain the written approval thereof by the Department describing the scope of work included and any special conditions under which approval is given (CAC, Section 7-113 (a)).

Construction or alteration of any health facility, governed under these regulations, performed without the benefit of review, permitting, and/or observation by the

Department when review, permitting and/or observation is required, and without the exemption by the Department provided for in Section 7-127, shall be subject to examination by the Department to assess relevant code compliance. Failure to obtain the necessary reviews and approvals prior to commencing construction will result in examination fees, in addition to application fees (CAC, Section 7-128).

CONNECTION FOR A TEMPORARY GENERATOR

The installation of a connection for a temporary generator requires a Building Permit but may be exempt from the plan review process in accordance with Health and Safety Code (H&SC) Section 129875. Simple installation of a connection for a temporary generator in qualifying SNFs and ICFs may be exempt from plan review, if the following criteria are met:

- One of the pre-approved designs included with package can be constructed without modification.
- The existing service is either 120/240 V or 208Y/120 V.
- The existing service is rated not more than 800 amps.
- The existing emergency generator will remain in service throughout the project.

This Expedited Building Permit Guide presents those criteria in a checklist format for general assessment of the specific project conditions. Installation of a connection for a temporary generator without a permit is subject to an investigation fee, submittal of a project to the Department for plan review, demolition and/or rework of defective non-code complying work, etc. in accordance with the California Administrative Code, Title 24, Part 1, Section 7-128 "*Work Performed without a Permit*".

The facility owner or his/her authorized agent should review this checklist with the **HCAI Compliance Officer** to determine program eligibility, to assess the specific project conditions and determination of possible approaches to the application, review, permitting, and construction process prior to proceeding with work. Possible approaches include, but are not limited to:

More than Minor Work – Not covered under this Expedited Building Permit Guide is the installation of a connection for a temporary generator where modification, repair, or remedial work is necessary to bring a system that did not comply with the code at the time it was installed into compliance with current code and/or to ensure a safe condition. The facility must involve a licensed design professional (architect and/or electrical engineer dependent upon the scope and nature of the remedial work). If this work is of sufficient limited scope, field review by the Compliance Officer can be used under this Expedited Building Permit Guide, however more involved work will require submittal as a standard project and reviewed by the Department by the Regional Architectural & Engineering Unit.

Determination of Eligibility – Determination of eligibility and appropriate permitting process is the responsibility of the HCAI Regional Compliance Officer. Facilities are encouraged to work with their Compliance Officer prior to assuming eligibility or an approach to permitting.

Inspections – The approved Inspector of Record (IOR) must inspect the work prior to use. Interim inspection will be required when walls, ceilings or other construction materials will cover the finished work. Any deficiencies, identified through inspection, shall be corrected before use of the system is permitted. A "Certificate of Compliance"

issued by the HCAI Compliance Officer is required prior to use of the connection. Responsible parties shall file Verified Compliance Reports (CAC, Section 7-151) in accordance with the requirements of the Testing, Inspection and Observation (TIO) Program (CAC, Section 7-149).

Manufacturer's Written Installation, Operating, and Maintenance Instructions –

The installation shall comply with the manufacturer's written installation instructions. The installer (facility's maintenance staff/contractor) shall leave or submit to the Compliance Officer the manufacturer's installation, operating, and maintenance instructions in a location on the premises where they will be readily available for reference and guidance for the Inspector of Record (IOR), HCAI staff, service personnel, and the owner or operator.

Electrical systems shall be installed in a manner that is in accordance with the California Electrical Code (CEC), applicable standards, and the manufacturer's installation instructions. (CEC 110.3)

New Project/Building Permit Application Requirements

- Step 1.** Verify that the project is eligible for this program. Consultation with the HCAI Compliance Officer is recommended.
- Step 2.** Use the eServices Portal online application process or download and print the Expedited Building Permit Guide and complete the **Installing a Connection for a Temporary Generator (Full Building Option) Code Compliance Checklist** beginning on Page 6 of this Guide and complete the **Application for New Project/Building Permit** available at the HCAI website or eServices Portal. These documents may be filled-in manually or electronically.
- Step 3.** Prepare a plan/sketch showing the location(s) of where the temporary generator will be installed (a reduced copy of the site plan may be used for this purpose). Complete the Data Collection Sheet, which is included in the document package.
- Step 4.** If not using the online application, print one (1) complete set of the entire package (the Expedited Building Permit Guide with completed Checklist and Applications), sign and date (where required), and mail or deliver to:

For construction in [Northern California](#), submit to:

Department of Health Care Access and Information
Facilities Development Division
2020 West El Camino Avenue, Suite 800
Sacramento, CA 95833
(916) 440-8300 phone
(916) 274-0102 fax

For construction in [Southern California](#), submit to:

Department of Health Care Access and Information
Facilities Development Division
355 South Grand Avenue, Suite 1900
Los Angeles, CA 90071
(213) 897-0166 phone
(213) 217-8511 fax

Upon issuance of the building permit for the project by HCAI, you may submit a construction start letter and begin work.

The following questions based on your answer may have requirements. These requirements will be communicated to you by the HCAI Regional Compliance Officer.

**INSTALLING A CONNECTION FOR A TEMPORARY GENERATOR
FULL BUILDING BACKUP OPTION
CODE COMPLIANCE CHECKLIST**

NOTE: The HCAI Compliance Officer will field verify compliance with the following checklist and additional work may be required to bring the installation into code compliance if found to be deficient.

		Compliance		
		Yes	No	NA
PROJECT DESCRIPTION				
1.	Is this project for a single-story skilled nursing or intermediate care facility building of wood-frame or light steel frame construction?	<input type="checkbox"/>	<input type="checkbox"/>	
2.	Is this project for the installation of a point of connection for a temporary generator that will back up the electrical service for the entire building?	<input type="checkbox"/>	<input type="checkbox"/>	
3.	Will this work be performed by an electrical contractor licensed in the State of California?	<input type="checkbox"/>	<input type="checkbox"/>	
4.	Does the licensed contractor carry workmen’s compensation insurance in accordance with State of California law?	<input type="checkbox"/>	<input type="checkbox"/>	
5.	Is the estimated cost of construction less than \$50,000?	<input type="checkbox"/>	<input type="checkbox"/>	
6.	Has the Data Collection Sheet for Full Building Backup (attached) been completed? If no, complete it before continuing. Note: Completion of the data collection sheet should be performed by a licensed electrical contractor.	<input type="checkbox"/>	<input type="checkbox"/>	

		Compliance		
		Yes	No	NA
7.	<p>Is there a location for the temporary generator that meets the following requirements?</p> <p>A. Is outdoors at grade level (NFPA 37, CBC 442) B. Close proximity to the concrete pad above and a clear route for cables C. Has dimensions of not less than 20' L X 9' W D. > 5 feet from the nearest building opening or combustible wall E. > 10 feet from the nearest air intake F. The area can be secured against tampering and theft G. Has ready access for a fuel truck H. Is accessible for maintenance, repair and fire-fighting (NFPA 37 4.1.1.1) I. Is out of the paths of egress, traffic, and fire department access J. Has receptacles nearby for battery charger and engine heater</p>	<input type="checkbox"/>	<input type="checkbox"/>	
8.	<p>Will the existing permanent emergency generator remain fully functional at all times (before, during and after construction)?</p> <p>Commentary: The connection being installed under this project is not a substitute for the required permanent emergency generator.</p>	<input type="checkbox"/>	<input type="checkbox"/>	
9.	<p>Will the temporary generator be used only for emergencies, such as Public Safety Power Shutoff (PSPS) events?</p> <p>Commentary: Any other uses must be approved by the local air quality management district.</p> <p>Commentary: Exceptions have been exercised that limit the use to emergencies only.</p>	<input type="checkbox"/>	<input type="checkbox"/>	
10.	<p>Has the Data Collection Sheet for Full Building Backup (attached) been completed? If not, complete it before continuing.</p> <p>Note: Completion of the data collection sheet should be performed by a licensed electrical contractor.</p>	<input type="checkbox"/>	<input type="checkbox"/>	
11.	<p>Does the building have only one electrical service?</p>	<input type="checkbox"/>	<input type="checkbox"/>	
12.	<p>Is the AIC rating of the existing service disconnect less than or equal to 65,000 amps?</p>	<input type="checkbox"/>	<input type="checkbox"/>	

						Compliance								
						Yes	No	NA						
13.	Review the following table. Does the existing electrical service meet the criteria for one or more of the design options?					<input type="checkbox"/>	<input type="checkbox"/>							
									Service Voltage		Service Amps		Kirk Key	Service Disconnect
									Voltage	PH/Wire	Min	Max	See Note 1	See Note 2
									120/240 Volts	1PH/3W	0	400	FB1-4-1	FB2-4-1
									120/240 Volts	1PH/3W	401	600	FB1-6-1	FB2-6-1
									120/240 Volts	1PH/3W	601	800	FB1-8-1	FB2-8-1
									120/240 Volts	3PH/4W	0	400	FB1-4-3	FB2-4-3
									120/240 Volts	3PH/4W	401	600	FB1-6-3	FB2-6-3
									120/240 Volts	3PH/4W	601	800	FB1-8-3	FB2-8-3
									208Y/120 Volts	3PH/4W	0	400	FB1-4-3	FB2-4-3
									208Y/120 Volts	3PH/4W	401	600	FB1-6-3	FB2-6-3
208Y/120 Volts	3PH/4W	601	800	FB1-8-3	FB2-8-3									
Notes:														
1. Is it possible to install a Kirk-Key interlock on the existing service disconnect? If so, the FB1 options are feasible.														
2. Is the connection between the service disconnect and switchboard bus accessible, able to be removed, and lugs installed on both the disconnect and bus? If so, the FB2 options are feasible.														
14.	Following approval by HCAI, perform the work as specified in the attached documents.													

DATA COLLECTION SHEET

FULL BUILDING BACKUP

Complete this form for each service being backed up. Where there are multiple services in one building, a separate project is required for each.

1. Meter Number _____

2. Service Voltage (Select one)
 - 120/240 V
 - 208Y/120
 - Other (specify) _____

3. Configuration (select one)
 - 1 phase 3 wire
 - 3 phase 4 wire
 - Other (specify) _____

4. Service rating (select one)
 - 400 amps
 - 600 amps
 - 800 amps
 - Other (specify) _____

5. Service disconnect interrupting rating _____ kA

6. Phase Rotation (circle one)
 - Clockwise
 - Counter-clockwise
 - N/A (Single phase)

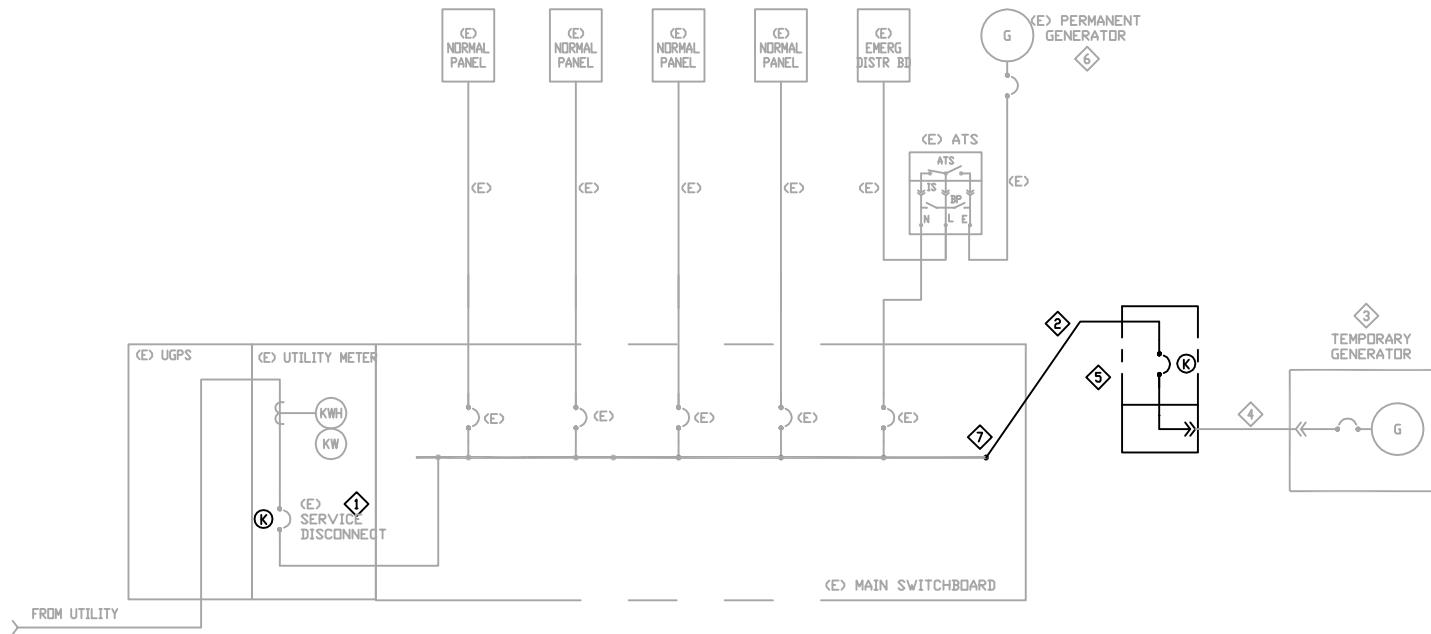

SHEET NOTES:

- ① EXISTING SERVICE DISCONNECT CIRCUIT BREAKER OR SWITCH. PROVIDE KIRK-KEY INTERLOCK WITH TEMPORARY GENERATOR BREAKER (SEE NOTE 5). ONLY ONE MAY BE CLOSED AT A TIME.
- ② FEEDER CONDUCTORS. 2 SETS 2" C W/ 3 #3/0 CU & 1 # 3 CU GND EA
- ③ TEMPORARY GENERATOR. MIN RATING 100 KW.
- ④ TEMPORARY FEEDER. SUPPLIED BY VENDOR OF TEMPORARY GENERATOR.
- ⑤ GENERATOR DOCKING STATION - SEE SPECIFICATIONS:
 - A. UL 1008 LISTED
 - B. 400 AMP 80% RATED CIRCUIT BREAKER DISCONNECT. TRIP RATING TO MATCH EXISTING SERVICE RATING.
 - C. 120/240 VOLTS 1 PHASE 3 WIRE TO MATCH (E) SYSTEM.
 - D. COLOR-CODED CAM STYLE MALE INLETS
 - E. NEMA 3R ENCLOSURE WITH PADLOCKABLE ACCESS AND DEAD FRONT PANEL.
 - F. ANCHOR PER DRAWING S-1.
 - G. PROVIDE KIRK KEY INTERLOCK WITH SERVICE DISCONNECT. ONLY ONE MAY BE CLOSED AT A TIME.
- ⑥ EXISTING PERMANENT GENERATOR. SHALL REMAIN OPERATIONAL AT ALL TIMES.
- ⑦ BUS TAP. SHALL BE FIELD LABELED BY A NATIONALLY RECOGNIZED TESTING LABORATORY (NRTL). MINIMIZE TIME THAT TRANSFER SWITCH IS WITHOUT NORMAL POWER. PROVIDE TEMPORARY GENERATOR AS NORMAL SOURCE UNLESS APPROVED BY HCAI COMPLIANCE OFFICER.

SEQUENCE:

CEC 517.41 REQUIRES TWO INDEPENDENT SOURCES OF POWER FOR THE ESSENTIAL ELECTRICAL SYSTEM AT ALL TIMES.

THE WORK SHOWN WILL DISABLE THE NORMAL POWER (UTILITY) FOR SOME PERIOD OF TIME. THE DURATION CAN BE MINIMIZED BY CAREFUL PLANNING, WHICH MAY INCLUDE THE NEED FOR A TEMPORARY GENERATOR.

THE CONTRACTOR SHALL PREPARE A PATIENT IMPACT REPORT AND SCHEDULE THAT SPECIFIES THE AREAS AFFECTED AND DURATIONS. PRIOR TO PROCEEDING WITH WORK, THE PLAN SHALL BE APPROVED BY THE BUILDING OWNER, HCAI COMPLIANCE OFFICER AND CALIFORNIA DEPARTMENT OF PUBLIC HEALTH, LICENSING AND CERTIFICATION DIVISION.

SINGLE LINE FULL BUILDING OPTION 1 - 400 AMP 1 PHASE 3 WIRE

DATE	REVISION
10/12/21	FINAL

NO:

FB1-4-1

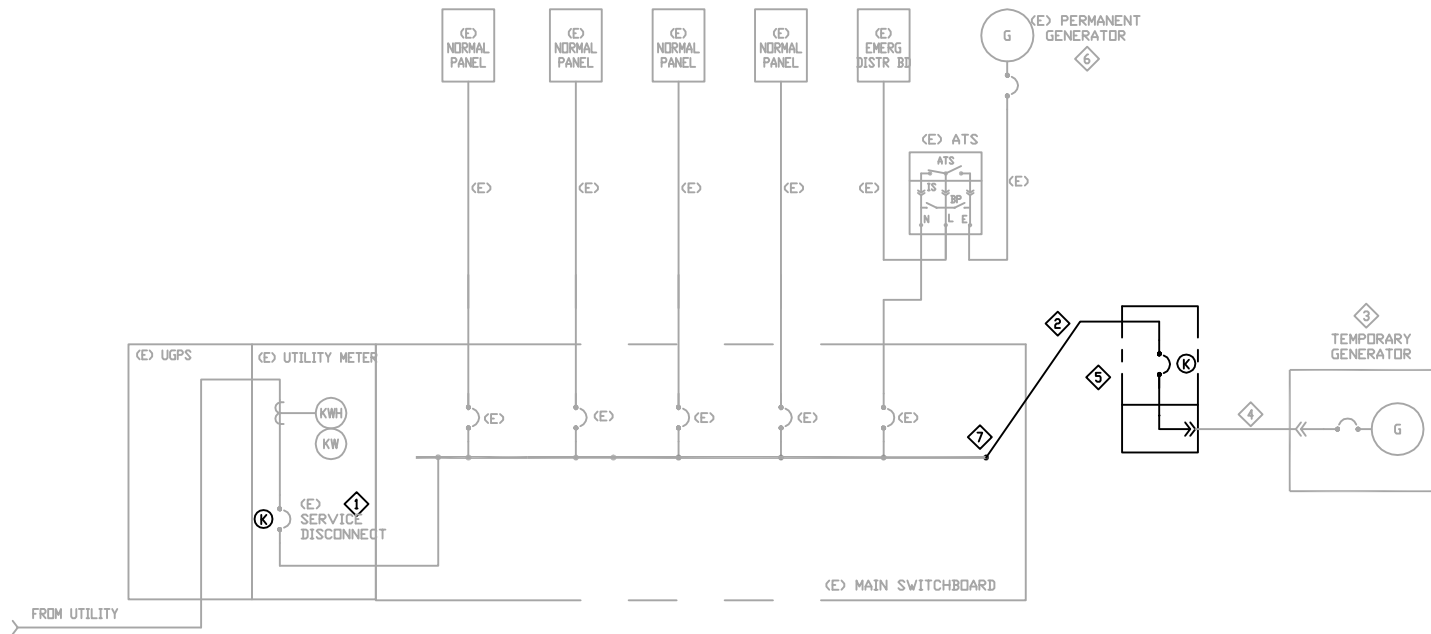

SHEET NOTES:

- ① EXISTING SERVICE DISCONNECT CIRCUIT BREAKER OR SWITCH. PROVIDE KIRK-KEY INTERLOCK WITH TEMPORARY GENERATOR BREAKER (SEE NOTE 5). ONLY ONE MAY BE CLOSED AT A TIME.
- ② FEEDER CONDUCTORS. 2 SETS 2" C W/ 4 #3/8 CU & 1 # 3 CU GND EA
- ③ TEMPORARY GENERATOR. MIN RATING 175 KW.
- ④ TEMPORARY FEEDER. SUPPLIED BY VENDOR OF TEMPORARY GENERATOR.
- ⑤ GENERATOR DOCKING STATION - SEE SPECIFICATIONS:
 - A. UL 1008 LISTED
 - B. 400 AMP 80% RATED CIRCUIT BREAKER DISCONNECT. TRIP RATING TO MATCH SERVICE DISCONNECT RATING.
 - C. 120/240 OR 208Y/120 VOLTS 3 PHASE 4 WIRE TO MATCH (E) SYSTEM.
 - D. COLOR-CODED CAM STYLE MALE INLETS
 - E. NEMA 3R ENCLOSURE WITH PADLOCKABLE ACCESS AND DEAD FRONT PANEL.
 - F. ANCHOR PER DRAWING S-1.
 - G. PROVIDE KIRK KEY INTERLOCK WITH SERVICE DISCONNECT. ONLY ONE MAY BE CLOSED AT A TIME.
- ⑥ EXISTING PERMANENT GENERATOR. SHALL REMAIN OPERATIONAL AT ALL TIMES.
- ⑦ BUS TAP. SHALL BE FIELD LABELED BY A NATIONALLY RECOGNIZED TESTING LABORATORY (NRTL). MINIMIZE TIME THAT TRANSFER SWITCH IS WITHOUT NORMAL POWER. PROVIDE TEMPORARY GENERATOR AS NORMAL SOURCE UNLESS APPROVED BY HCAI COMPLIANCE OFFICER.

SEQUENCE:

CEC 517.41 REQUIRES TWO INDEPENDENT SOURCES OF POWER FOR THE ESSENTIAL ELECTRICAL SYSTEM AT ALL TIMES.

THE WORK SHOWN WILL DISABLE THE NORMAL POWER (UTILITY) FOR SOME PERIOD OF TIME. THE DURATION CAN BE MINIMIZED BY CAREFUL PLANNING, WHICH MAY INCLUDE THE NEED FOR A TEMPORARY GENERATOR.

THE CONTRACTOR SHALL PREPARE A PATIENT IMPACT REPORT AND SCHEDULE THAT SPECIFIES THE AREAS AFFECTED AND DURATIONS. PRIOR TO PROCEEDING WITH WORK, THE PLAN SHALL BE APPROVED BY THE BUILDING OWNER, HCAI COMPLIANCE OFFICER AND CALIFORNIA DEPARTMENT OF PUBLIC HEALTH, LICENSING AND CERTIFICATION DIVISION.

SINGLE LINE FULL BUILDING OPTION 1 - 400 AMP 3 PHASE 4 WIRE

DATE	REVISION
10/12/21	FINAL

NO:

FB1-4-3

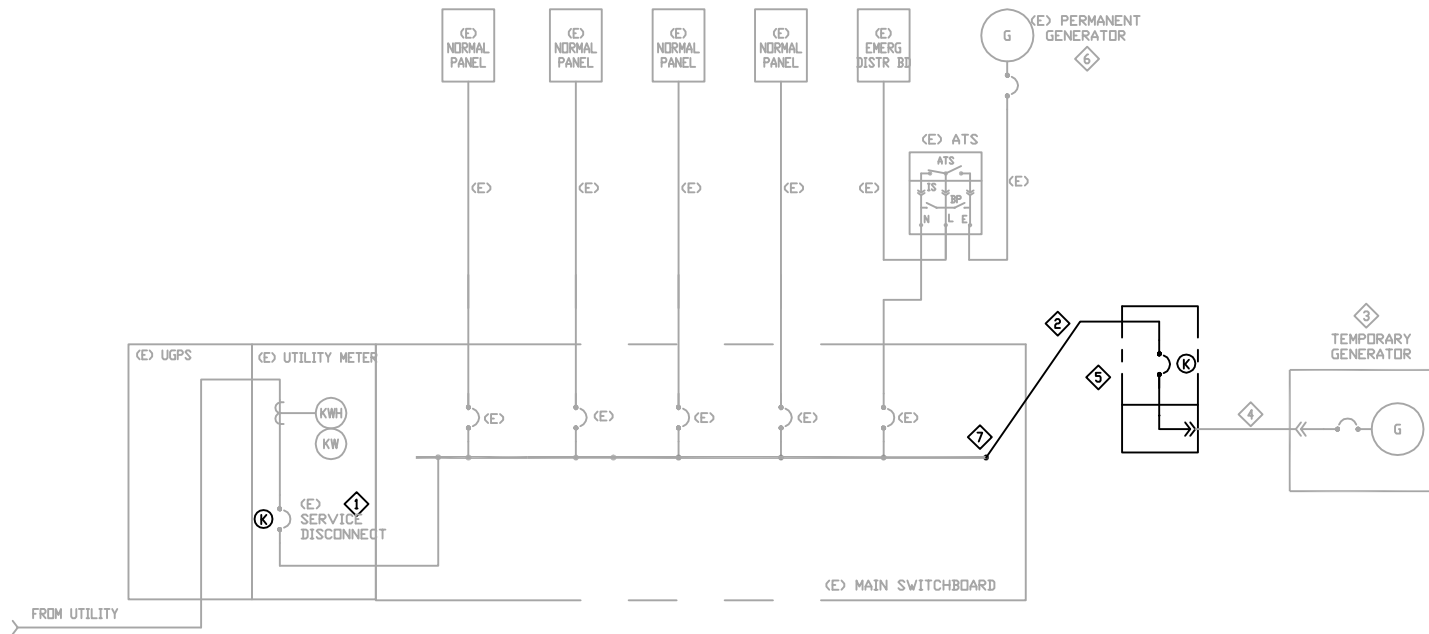

SHEET NOTES:

- ① EXISTING SERVICE DISCONNECT CIRCUIT BREAKER OR SWITCH. PROVIDE KIRK-KEY INTERLOCK WITH TEMPORARY GENERATOR BREAKER (SEE NOTE 5). ONLY ONE MAY BE CLOSED AT A TIME.
- ② FEEDER CONDUCTORS. 2 SETS 2 1/2" C W/ 3#350 KCMIL CU & 1 # 1 CU GND EA
- ③ TEMPORARY GENERATOR. MIN RATING 150 KW.
- ④ TEMPORARY FEEDER. SUPPLIED BY VENDOR OF TEMPORARY GENERATOR.
- ⑤ GENERATOR DOCKING STATION - SEE SPECIFICATIONS
 - A. UL 1008 LISTED
 - B. 600 AMP 80% RATED CIRCUIT BREAKER DISCONNECT
 - C. 120/240 VOLTS 1 PHASE 3 WIRE TO MATCH (E) SYSTEM.
 - D. COLOR-CODED CAM STYLE MALE INLETS
 - E. NEMA 3R ENCLOSURE WITH PADLOCKABLE ACCESS AND DEAD FRONT PANEL.
 - F. ANCHOR PER DRAWING S-1.
 - G. PROVIDE KIRK KEY INTERLOCK WITH SERVICE DISCONNECT. ONLY ONE MAY BE CLOSED AT A TIME.
- ⑥ EXISTING PERMANENT GENERATOR. SHALL REMAIN OPERATIONAL AT ALL TIMES.
- ⑦ BUS TAP. SHALL BE FIELD LABELED BY A NATIONALLY RECOGNIZED TESTING LABORATORY (NRTL). MINIMIZE TIME THAT TRANSFER SWITCH IS WITHOUT NORMAL POWER. PROVIDE TEMPORARY GENERATOR AS NORMAL SOURCE UNLESS APPROVED BY HCAI COMPLIANCE OFFICER.

SEQUENCE:

CEC 517.41 REQUIRES TWO INDEPENDENT SOURCES OF POWER FOR THE ESSENTIAL ELECTRICAL SYSTEM AT ALL TIMES.

THE WORK SHOWN WILL DISABLE THE NORMAL POWER (UTILITY) FOR SOME PERIOD OF TIME. THE DURATION CAN BE MINIMIZED BY CAREFUL PLANNING, WHICH MAY INCLUDE THE NEED FOR A TEMPORARY GENERATOR.

THE CONTRACTOR SHALL PREPARE A PATIENT IMPACT REPORT AND SCHEDULE THAT SPECIFIES THE AREAS AFFECTED AND DURATIONS. PRIOR TO PROCEEDING WITH WORK, THE PLAN SHALL BE APPROVED BY THE BUILDING OWNER, HCAI COMPLIANCE OFFICER AND CALIFORNIA DEPARTMENT OF PUBLIC HEALTH, LICENSING AND CERTIFICATION DIVISION.

SINGLE LINE FULL BUILDING OPTION 1 - 600 AMP 1 PHASE 3 WIRE

DATE	REVISION
10/12/21	FINAL

NO:

FB1-6-1

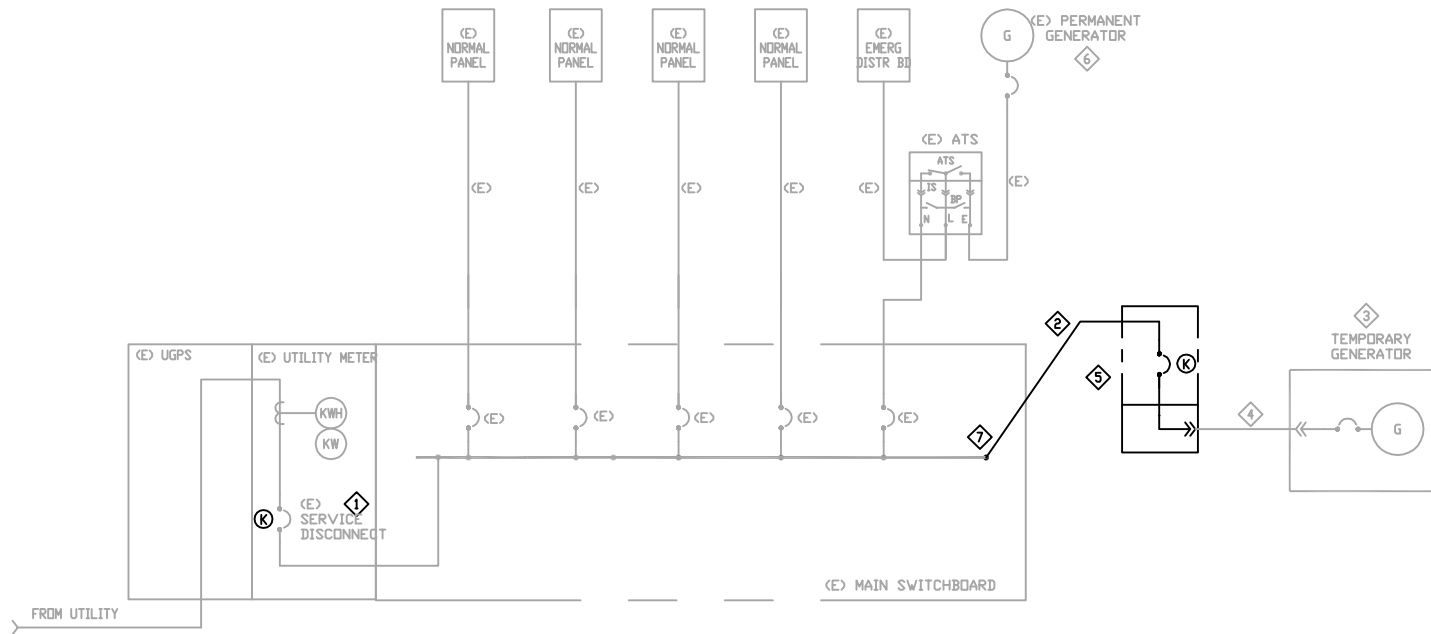

SHEET NOTES:

- ① EXISTING SERVICE DISCONNECT CIRCUIT BREAKER OR SWITCH. PROVIDE KIRK-KEY INTERLOCK WITH TEMPORARY GENERATOR BREAKER (SEE NOTE 5). ONLY ONE MAY BE CLOSED AT A TIME.
- ② FEEDER CONDUCTORS. 2 SETS 3" C W/ 4#350 KCMIL CU & 1 # 1 CU GND EA
- ③ TEMPORARY GENERATOR. MIN RATING 250 KW.
- ④ TEMPORARY FEEDER. SUPPLIED BY VENDOR OF TEMPORARY GENERATOR.
- ⑤ GENERATOR DOCKING STATION - SEE SPECIFICATIONS:
 - A. UL 1008 LISTED
 - B. 600 AMP 80% RATED CIRCUIT BREAKER DISCONNECT
 - C. 120/240 OR 208Y/120 VOLTS 3 PHASE 4 WIRE TO MATCH (E) SYSTEM.
 - D. COLOR-CODED CAM STYLE MALE INLETS
 - E. NEMA 3R ENCLOSURE WITH PADLOCKABLE ACCESS AND DEAD FRONT PANEL.
 - F. ANCHOR PER DRAWING S-1.
 - G. PROVIDE KIRK KEY INTERLOCK WITH SERVICE DISCONNECT. ONLY ONE MAY BE CLOSED AT A TIME.
- ⑥ EXISTING PERMANENT GENERATOR. SHALL REMAIN OPERATIONAL AT ALL TIMES.
- ⑦ BUS TAP. SHALL BE FIELD LABELED BY A NATIONALLY RECOGNIZED TESTING LABORATORY (NRTL). MINIMIZE TIME THAT TRANSFER SWITCH IS WITHOUT NORMAL POWER. PROVIDE TEMPORARY GENERATOR AS NORMAL SOURCE UNLESS APPROVED BY HCAI COMPLIANCE OFFICER.

SEQUENCE:

CEC 517.41 REQUIRES TWO INDEPENDENT SOURCES OF POWER FOR THE ESSENTIAL ELECTRICAL SYSTEM AT ALL TIMES.

THE WORK SHOWN WILL DISABLE THE NORMAL POWER (UTILITY) FOR SOME PERIOD OF TIME. THE DURATION CAN BE MINIMIZED BY CAREFUL PLANNING, WHICH MAY INCLUDE THE NEED FOR A TEMPORARY GENERATOR.

THE CONTRACTOR SHALL PREPARE A PATIENT IMPACT REPORT AND SCHEDULE THAT SPECIFIES THE AREAS AFFECTED AND DURATIONS. PRIOR TO PROCEEDING WITH WORK, THE PLAN SHALL BE APPROVED BY THE BUILDING OWNER, HCAI COMPLIANCE OFFICER AND CALIFORNIA DEPARTMENT OF PUBLIC HEALTH, LICENSING AND CERTIFICATION DIVISION.

SINGLE LINE FULL BUILDING OPTION 1 - 600 AMP 3 PHASE 4 WIRE

DATE	REVISION
10/12/21	FINAL

NO:

FB1-6-3

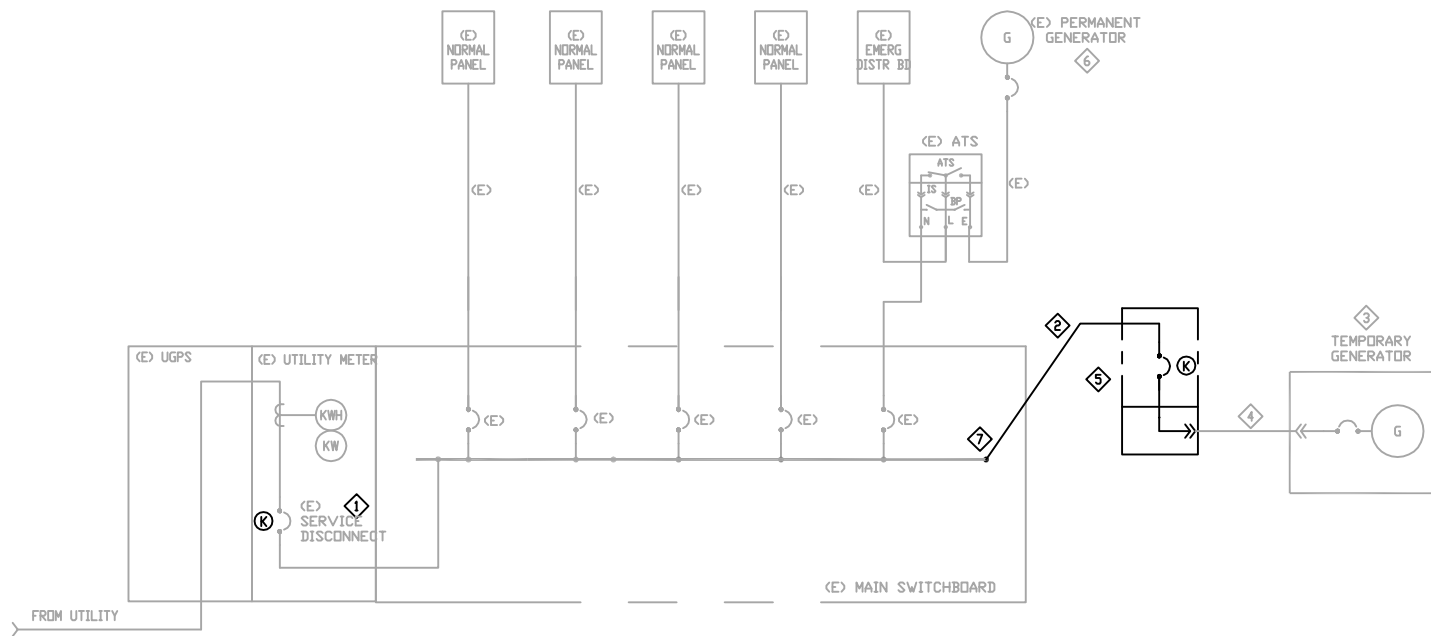

SHEET NOTES:

- ① EXISTING SERVICE DISCONNECT CIRCUIT BREAKER OR SWITCH. PROVIDE KIRK-KEY INTERLOCK WITH TEMPORARY GENERATOR BREAKER (SEE NOTE 5). ONLY ONE MAY BE CLOSED AT A TIME.
- ② FEEDER CONDUCTORS. 3 SETS 2 1/2" C W/ 3#300 KCMIL CU & 1 # 3/8" GND EA
- ③ TEMPORARY GENERATOR. MIN RATING 200 KW.
- ④ TEMPORARY FEEDER. SUPPLIED BY VENDOR OF TEMPORARY GENERATOR.
- ⑤ GENERATOR DOCKING STATION - SEE SPECIFICATIONS:
 - A. UL 1008 LISTED
 - B. 800 AMP 80% RATED CIRCUIT BREAKER DISCONNECT
 - C. 120/240 VOLTS 1 PHASE 3 WIRE TO MATCH (E) SYSTEM.
 - D. COLOR-CODED CAM STYLE MALE INLETS
 - E. NEMA 3R ENCLOSURE WITH PADLOCKABLE ACCESS AND DEAD FRONT PANEL.
 - F. ANCHOR PER DRAWING S-1.
 - G. PROVIDE KIRK KEY INTERLOCK WITH SERVICE DISCONNECT. ONLY ONE MAY BE CLOSED AT A TIME.
- ⑥ EXISTING PERMANENT GENERATOR. SHALL REMAIN OPERATIONAL AT ALL TIMES.
- ⑦ BUS TAP. SHALL BE FIELD LABELED BY A NATIONALLY RECOGNIZED TESTING LABORATORY (NRTL). MINIMIZE TIME THAT TRANSFER SWITCH IS WITHOUT NORMAL POWER. PROVIDE TEMPORARY GENERATOR AS NORMAL SOURCE UNLESS APPROVED BY HCAI COMPLIANCE OFFICER.

SEQUENCE:

CEC 517.41 REQUIRES TWO INDEPENDENT SOURCES OF POWER FOR THE ESSENTIAL ELECTRICAL SYSTEM AT ALL TIMES.

THE WORK SHOWN WILL DISABLE THE NORMAL POWER (UTILITY) FOR SOME PERIOD OF TIME. THE DURATION CAN BE MINIMIZED BY CAREFUL PLANNING, WHICH MAY INCLUDE THE NEED FOR A TEMPORARY GENERATOR.

THE CONTRACTOR SHALL PREPARE A PATIENT IMPACT REPORT AND SCHEDULE THAT SPECIFIES THE AREAS AFFECTED AND DURATIONS. PRIOR TO PROCEEDING WITH WORK, THE PLAN SHALL BE APPROVED BY THE BUILDING OWNER, HCAI COMPLIANCE OFFICER AND CALIFORNIA DEPARTMENT OF PUBLIC HEALTH, LICENSING AND CERTIFICATION DIVISION.

SINGLE LINE FULL BUILDING OPTION 1 - 800 AMP 1 PHASE 3 WIRE

DATE	REVISION
10/12/21	FINAL

NO:

FB1-8-1

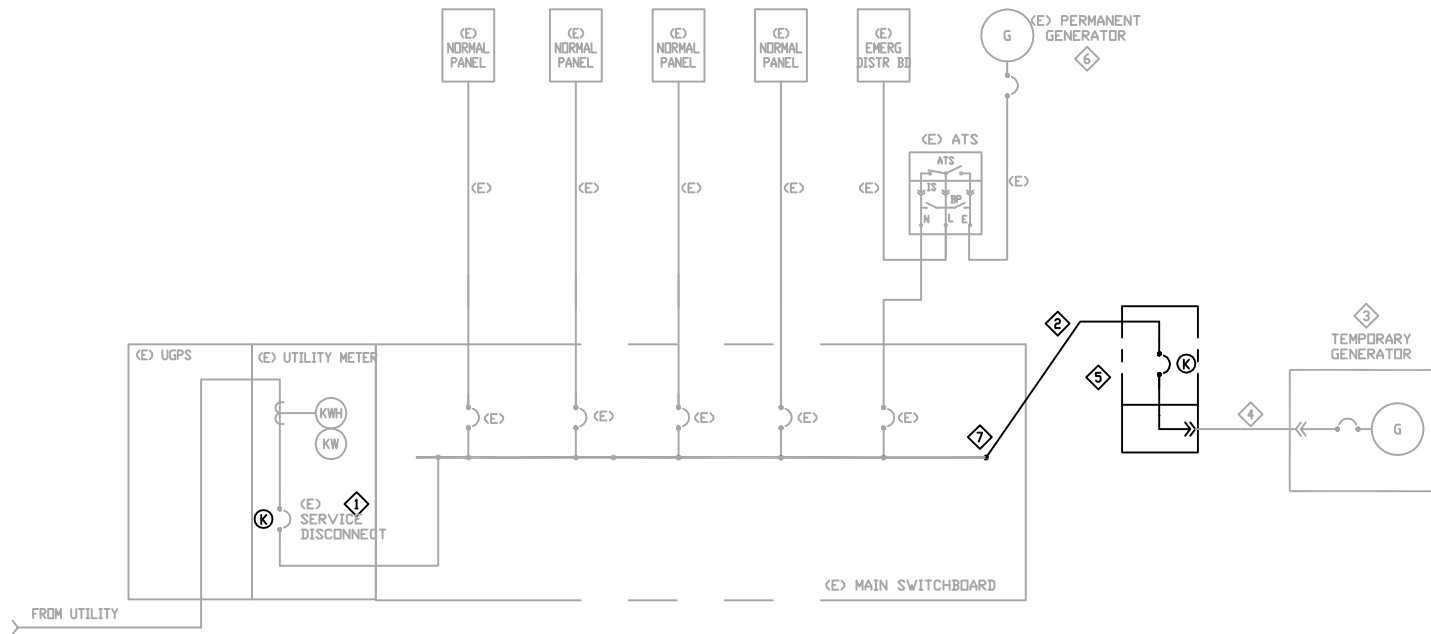

SHEET NOTES:

- ① EXISTING SERVICE DISCONNECT CIRCUIT BREAKER OR SWITCH. PROVIDE KIRK-KEY INTERLOCK WITH TEMPORARY GENERATOR BREAKER (SEE NOTE 5). ONLY ONE MAY BE CLOSED AT A TIME.
- ② FEEDER CONDUCTORS. 3 SETS 3" C W/ 4#300 KCMIL CU & 1 # 3/4 GND EA
- ③ TEMPORARY GENERATOR. MIN RATING 350 KW.
- ④ TEMPORARY FEEDER. SUPPLIED BY VENDOR OF TEMPORARY GENERATOR.
- ⑤ GENERATOR DOCKING STATION - SEE SPECIFICATIONS:
 - A. UL 1008 LISTED
 - B. 800 AMP 80% RATED CIRCUIT BREAKER DISCONNECT
 - C. 120/240 OR 208Y/120 VOLTS 3 PHASE 4 WIRE TO MATCH (E) SYSTEM.
 - D. COLOR-CODED CAM STYLE MALE INLETS
 - E. NEMA 3R ENCLOSURE WITH PADLOCKABLE ACCESS AND DEAD FRONT PANEL.
 - F. ANCHOR PER DRAWING S-1.
 - G. PROVIDE KIRK KEY INTERLOCK WITH SERVICE DISCONNECT. ONLY ONE MAY BE CLOSED AT A TIME.
- ⑥ EXISTING PERMANENT GENERATOR. SHALL REMAIN OPERATIONAL AT ALL TIMES.
- ⑦ BUS TAP. SHALL BE FIELD LABELED BY A NATIONALLY RECOGNIZED TESTING LABORATORY (NRTL). MINIMIZE TIME THAT TRANSFER SWITCH IS WITHOUT NORMAL POWER. PROVIDE TEMPORARY GENERATOR AS NORMAL SOURCE UNLESS APPROVED BY HCAI COMPLIANCE OFFICER.

SEQUENCE:

CEC 517.41 REQUIRES TWO INDEPENDENT SOURCES OF POWER FOR THE ESSENTIAL ELECTRICAL SYSTEM AT ALL TIMES.

THE WORK SHOWN WILL DISABLE THE NORMAL POWER (UTILITY) FOR SOME PERIOD OF TIME. THE DURATION CAN BE MINIMIZED BY CAREFUL PLANNING, WHICH MAY INCLUDE THE NEED FOR A TEMPORARY GENERATOR.

THE CONTRACTOR SHALL PREPARE A PATIENT IMPACT REPORT AND SCHEDULE THAT SPECIFIES THE AREAS AFFECTED AND DURATIONS. PRIOR TO PROCEEDING WITH WORK, THE PLAN SHALL BE APPROVED BY THE BUILDING OWNER, HCAI COMPLIANCE OFFICER AND CALIFORNIA DEPARTMENT OF PUBLIC HEALTH, LICENSING AND CERTIFICATION DIVISION.

SINGLE LINE FULL BUILDING OPTION 1 - 800 AMP 3 PHASE 4 WIRE

DATE	REVISION
10/12/21	FINAL

NO:

FB1-8-3

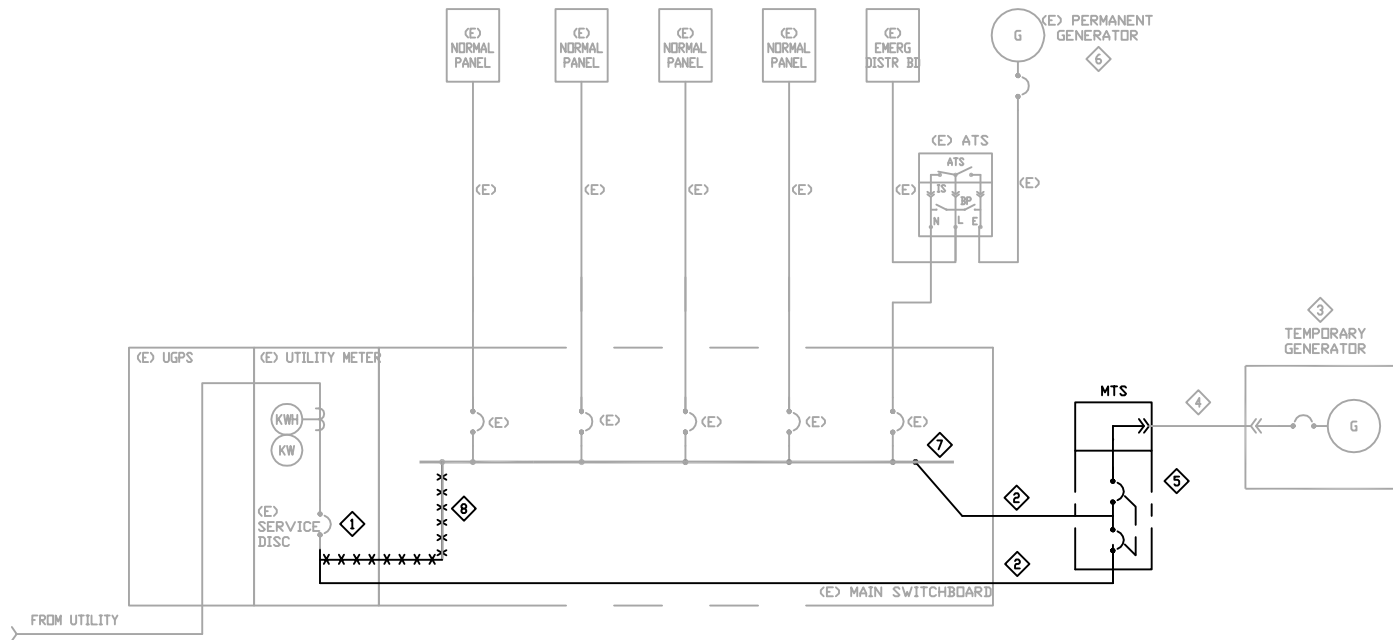

SHEET NOTES:

- ① EXISTING SERVICE DISCONNECT CIRCUIT BREAKER OR SWITCH.
- ② FEEDER CONDUCTORS: 2 SETS 2" C W/ 3 # 3/0 CU & 1 # 3 CU GND EA
- ③ TEMPORARY GENERATOR: MIN RATING 100 KW.
- ④ TEMPORARY FEEDER. SUPPLIED BY VENDOR OF TEMPORARY GENERATOR.
- ⑤ MANUAL TRANSFER SWITCH (MTS) :
 - A. 400 AMP 80% RATED BREAKERS.
 - B. 120/240 VOLTS 1 PHASE 3 WIRE TO MATCH (E) SERVICE. UNSWITCHED NEUTRAL CONNECTION.
 - C. SHALL BE LISTED UL 1008 AND CERTIFIED HCAI OSP-582-10.
 - D. ANCHOR PER DRAWING S-1.
- ⑥ EXISTING PERMANENT GENERATOR. SHALL REMAIN OPERATIONAL AT ALL TIMES.
- ⑦ BUS TAP. SHALL BE FIELD LABELED BY A NATIONALLY RECOGNIZED TESTING LABORATORY (NRTL). MINIMIZE TIME THAT TRANSFER SWITCH IS WITHOUT NORMAL POWER. PROVIDE TEMPORARY GENERATOR AS NORMAL SOURCE UNLESS APPROVED BY HCAI COMPLIANCE OFFICER.
- ⑧ REMOVE CONNECTION BETWEEN SERVICE DISCONNECT AND BUS. PROVIDE LUGS ON BREAKER, MINIMIZE TIME THAT TRANSFER SWITCH IS WITHOUT NORMAL POWER. PROVIDE TEMPORARY GENERATOR AS NORMAL SOURCE UNLESS APPROVED BY HCAI COMPLIANCE OFFICER.

SEQUENCE:

CEC 517.41 REQUIRES TWO INDEPENDENT SOURCES OF POWER FOR THE ESSENTIAL ELECTRICAL SYSTEM AT ALL TIMES.

THE WORK SHOWN WILL DISABLE THE NORMAL POWER (UTILITY) FOR SOME PERIOD OF TIME. THE DURATION CAN BE MINIMIZED BY CAREFUL PLANNING, WHICH MAY INCLUDE THE NEED FOR A TEMPORARY GENERATOR.

THE CONTRACTOR SHALL PREPARE A PATIENT IMPACT REPORT AND SCHEDULE THAT SPECIFIES THE AREAS AFFECTED AND DURATIONS. PRIOR TO PROCEEDING WITH WORK, THE PLAN SHALL BE APPROVED BY THE BUILDING OWNER, HCAI COMPLIANCE OFFICER AND CALIFORNIA DEPARTMENT OF PUBLIC HEALTH, LICENSING AND CERTIFICATION DIVISION.

SINGLE LINE FULL BUILDING OPTION 2 - 400 AMPS 1 PHASE 3 WIRE

DATE	REVISION
10/12/21	FINAL

NO:

FB2-4-1

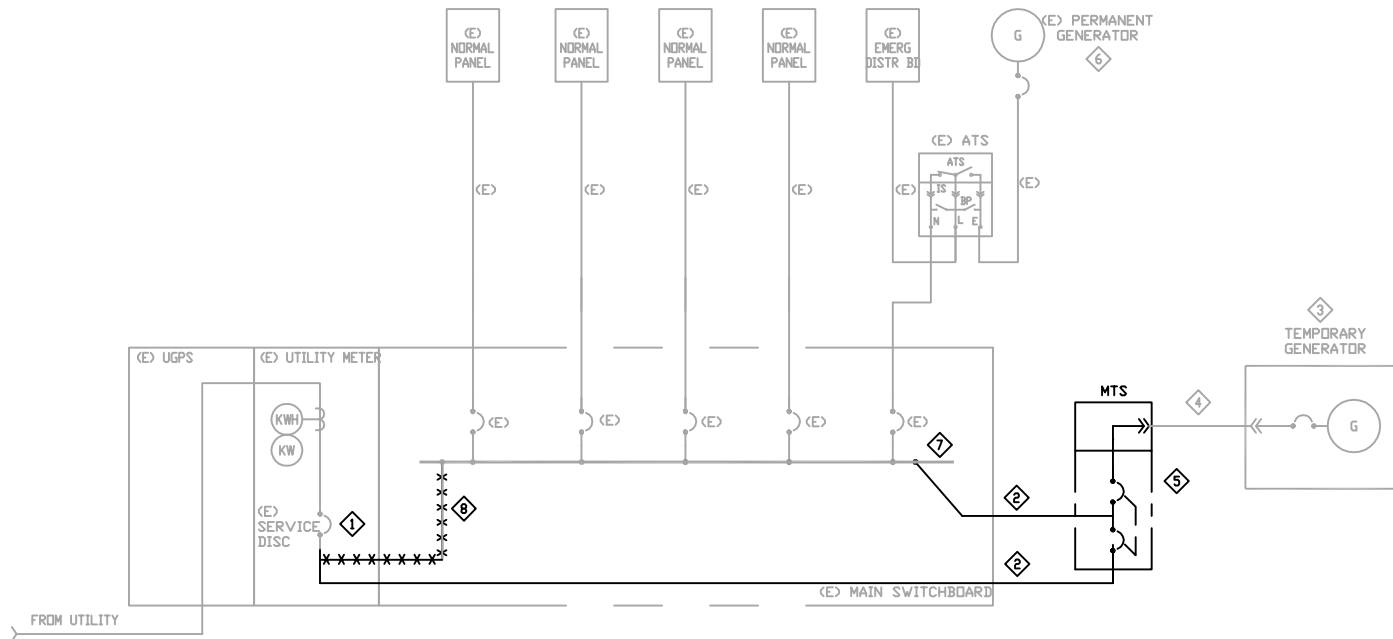

SHEET NOTES:

- ① EXISTING SERVICE DISCONNECT CIRCUIT BREAKER OR SWITCH.
- ② FEEDER CONDUCTORS: 2 SETS 2" C W/ 4 # 3/0 CU & 1 # 3 CU GND EA
- ③ TEMPORARY GENERATOR: MIN RATING 175 KW.
- ④ TEMPORARY FEEDER. SUPPLIED BY VENDOR OF TEMPORARY GENERATOR.
- ⑤ MANUAL TRANSFER SWITCH (MTS) :
 - A. 400 AMP 80% RATED BREAKERS.
 - B. 120/240 OR 208Y/120 VOLTS 3 PHASE 4 WIRE TO MATCH (E) SERVICE. UNSWITCHED NEUTRAL CONNECTION.
 - C. SHALL BE LISTED UL 1008 AND CERTIFIED HCAI OSP-582-10.
 - D. ANCHOR PER DRAWING S-1.
- ⑥ EXISTING PERMANENT GENERATOR. SHALL REMAIN OPERATIONAL AT ALL TIMES.
- ⑦ BUS TAP. SHALL BE FIELD LABELED BY A NATIONALLY RECOGNIZED TESTING LABORATORY (NRTL). MINIMIZE TIME THAT TRANSFER SWITCH IS WITHOUT NORMAL POWER. PROVIDE TEMPORARY GENERATOR AS NORMAL SOURCE UNLESS APPROVED BY HCAI COMPLIANCE OFFICER.
- ⑧ REMOVE CONNECTION BETWEEN SERVICE DISCONNECT AND BUS. PROVIDE LUGS ON BREAKER, MINIMIZE TIME THAT TRANSFER SWITCH IS WITHOUT NORMAL POWER. PROVIDE TEMPORARY GENERATOR AS NORMAL SOURCE UNLESS APPROVED BY HCAI COMPLIANCE OFFICER.

SEQUENCE:

CEC 517.41 REQUIRES TWO INDEPENDENT SOURCES OF POWER FOR THE ESSENTIAL ELECTRICAL SYSTEM AT ALL TIMES.

THE WORK SHOWN WILL DISABLE THE NORMAL POWER (UTILITY) FOR SOME PERIOD OF TIME. THE DURATION CAN BE MINIMIZED BY CAREFUL PLANNING, WHICH MAY INCLUDE THE NEED FOR A TEMPORARY GENERATOR.

THE CONTRACTOR SHALL PREPARE A PATIENT IMPACT REPORT AND SCHEDULE THAT SPECIFIES THE AREAS AFFECTED AND DURATIONS. PRIOR TO PROCEEDING WITH WORK, THE PLAN SHALL BE APPROVED BY THE BUILDING OWNER, HCAI COMPLIANCE OFFICER AND CALIFORNIA DEPARTMENT OF PUBLIC HEALTH, LICENSING AND CERTIFICATION DIVISION.

SINGLE LINE FULL BUILDING OPTION 2 - 400 AMPS 3 PHASE 4 WIRE

DATE	REVISION
10/12/21	FINAL

NO:

FB2-4-3

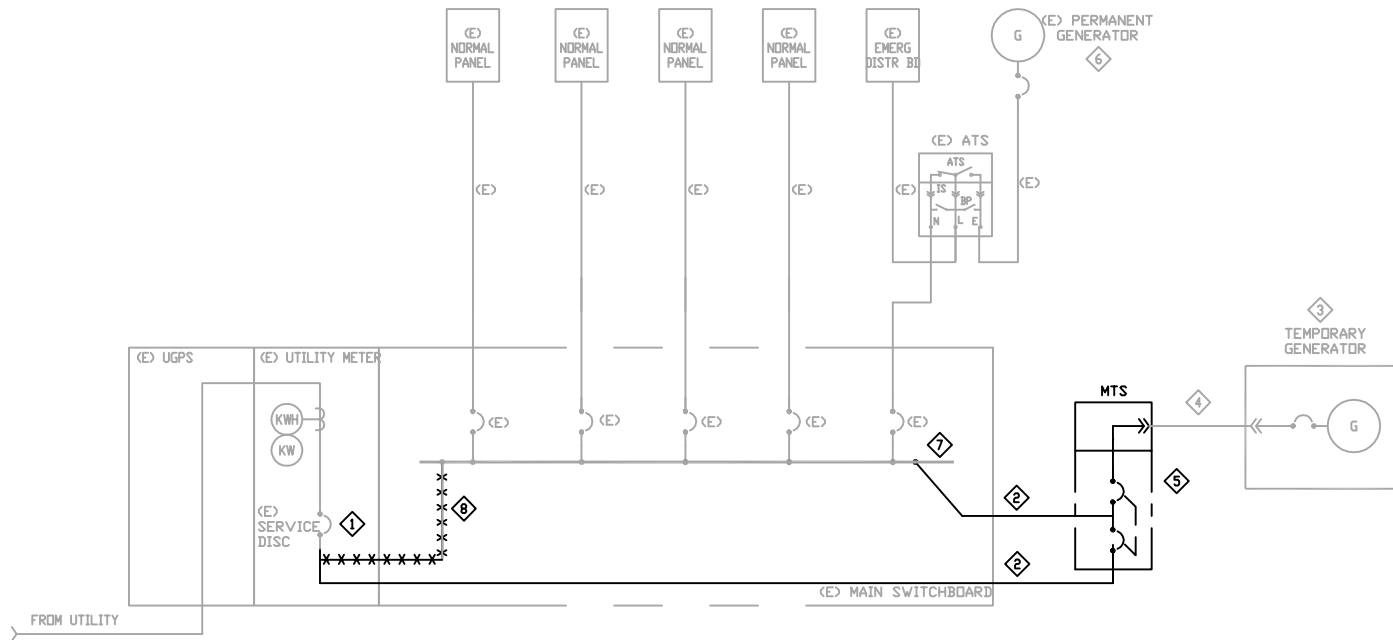

SHEET NOTES:

- ① EXISTING SERVICE DISCONNECT CIRCUIT BREAKER OR SWITCH.
- ② FEEDER CONDUCTORS: 2 SETS 2 ½" C W/ 3 #350 KCMIL CU & 1 # 1 CU GND EA
- ③ TEMPORARY GENERATOR: MIN RATING 150 KW
- ④ TEMPORARY FEEDER. SUPPLIED BY VENDOR OF TEMPORARY GENERATOR.
- ⑤ MANUAL TRANSFER SWITCH (MTS) :
 - A. 600 AMP 80% RATED BREAKERS.
 - B. 120/240 VOLTS 1 PHASE 3 WIRE TO MATCH (E) SERVICE. UNSWITCHED NEUTRAL CONNECTION.
 - C. SHALL BE LISTED UL 1008 AND CERTIFIED HCAI OSP-582-10.
 - D. ANCHOR PER DRAWING S-1.
- ⑥ EXISTING PERMANENT GENERATOR. SHALL REMAIN OPERATIONAL AT ALL TIMES.
- ⑦ BUS TAP. SHALL BE FIELD LABELED BY A NATIONALLY RECOGNIZED TESTING LABORATORY (NRTL). MINIMIZE TIME THAT TRANSFER SWITCH IS WITHOUT NORMAL POWER. PROVIDE TEMPORARY GENERATOR AS NORMAL SOURCE UNLESS APPROVED BY HCAI COMPLIANCE OFFICER.
- ⑧ REMOVE CONNECTION BETWEEN SERVICE DISCONNECT AND BUS. PROVIDE LUGS ON BREAKER, MINIMIZE TIME THAT TRANSFER SWITCH IS WITHOUT NORMAL POWER. PROVIDE TEMPORARY GENERATOR AS NORMAL SOURCE UNLESS APPROVED BY HCAI COMPLIANCE OFFICER.

SEQUENCE:

CEC 517.41 REQUIRES TWO INDEPENDENT SOURCES OF POWER FOR THE ESSENTIAL ELECTRICAL SYSTEM AT ALL TIMES.

THE WORK SHOWN WILL DISABLE THE NORMAL POWER (UTILITY) FOR SOME PERIOD OF TIME. THE DURATION CAN BE MINIMIZED BY CAREFUL PLANNING, WHICH MAY INCLUDE THE NEED FOR A TEMPORARY GENERATOR.

THE CONTRACTOR SHALL PREPARE A PATIENT IMPACT REPORT AND SCHEDULE THAT SPECIFIES THE AREAS AFFECTED AND DURATIONS. PRIOR TO PROCEEDING WITH WORK, THE PLAN SHALL BE APPROVED BY THE BUILDING OWNER, HCAI COMPLIANCE OFFICER AND CALIFORNIA DEPARTMENT OF PUBLIC HEALTH, LICENSING AND CERTIFICATION DIVISION.

SINGLE LINE FULL BUILDING OPTION 2 - 600 AMP 1 PHASE 3 WIRE

DATE	REVISION
10/12/21	FINAL

NO:

FB2-6-1

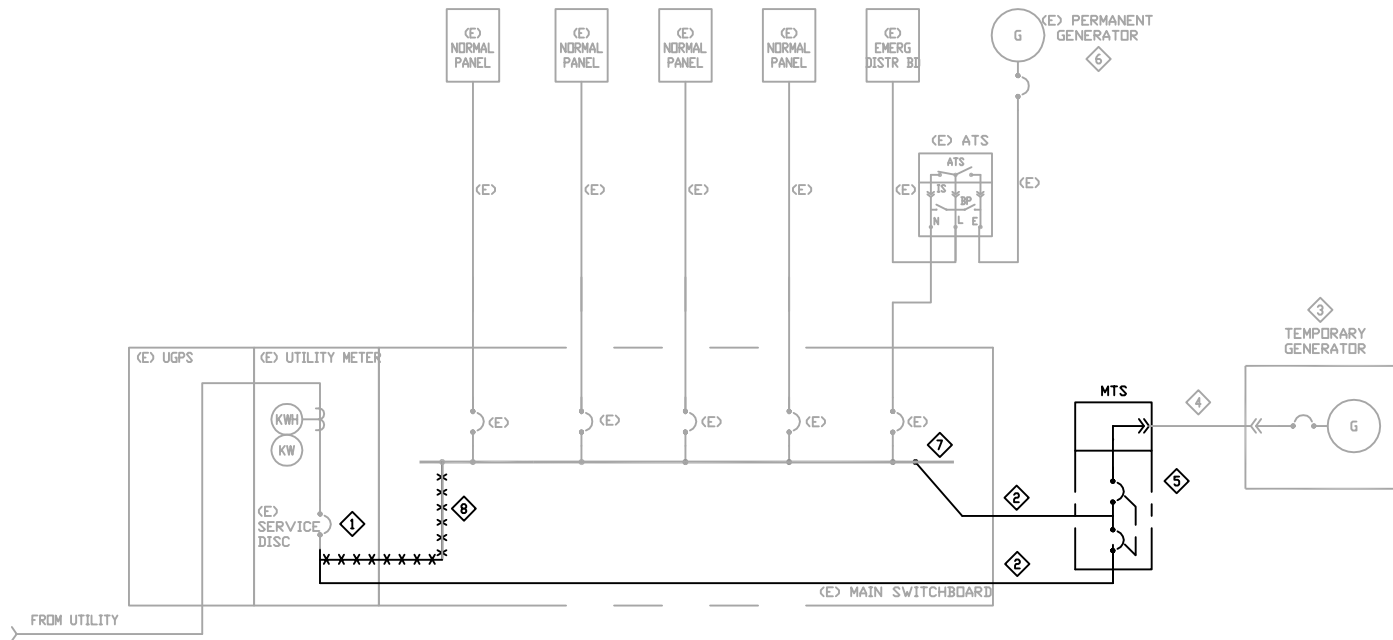

SHEET NOTES:

- ① EXISTING SERVICE DISCONNECT CIRCUIT BREAKER OR SWITCH.
- ② FEEDER CONDUCTORS: 2 SETS 3" C W/ 4 #350 KCMIL CU & 1 # 1 CU GND EA
- ③ TEMPORARY GENERATOR: MIN RATING 250 KW
- ④ TEMPORARY FEEDER. SUPPLIED BY VENDOR OF TEMPORARY GENERATOR.
- ⑤ MANUAL TRANSFER SWITCH (MTS) :
 - A. 600 AMP 80% RATED BREAKERS.
 - B. 120/240 OR 208Y/120 VOLTS 3 PHASE 4 WIRE TO MATCH (E) SERVICE. UNSWITCHED NEUTRAL CONNECTION.
 - C. SHALL BE LISTED UL 1008 AND CERTIFIED HCAI OSP-582-10.
 - D. ANCHOR PER DRAWING S-1.
- ⑥ EXISTING PERMANENT GENERATOR. SHALL REMAIN OPERATIONAL AT ALL TIMES.
- ⑦ BUS TAP. SHALL BE FIELD LABELED BY A NATIONALLY RECOGNIZED TESTING LABORATORY (NRTL). MINIMIZE TIME THAT TRANSFER SWITCH IS WITHOUT NORMAL POWER. PROVIDE TEMPORARY GENERATOR AS NORMAL SOURCE UNLESS APPROVED BY HCAI COMPLIANCE OFFICER.
- ⑧ REMOVE CONNECTION BETWEEN SERVICE DISCONNECT AND BUS. PROVIDE LUGS ON BREAKER, MINIMIZE TIME THAT TRANSFER SWITCH IS WITHOUT NORMAL POWER. PROVIDE TEMPORARY GENERATOR AS NORMAL SOURCE UNLESS APPROVED BY HCAI COMPLIANCE OFFICER.

SEQUENCE:

CEC 517.41 REQUIRES TWO INDEPENDENT SOURCES OF POWER FOR THE ESSENTIAL ELECTRICAL SYSTEM AT ALL TIMES.

THE WORK SHOWN WILL DISABLE THE NORMAL POWER (UTILITY) FOR SOME PERIOD OF TIME. THE DURATION CAN BE MINIMIZED BY CAREFUL PLANNING, WHICH MAY INCLUDE THE NEED FOR A TEMPORARY GENERATOR.

THE CONTRACTOR SHALL PREPARE A PATIENT IMPACT REPORT AND SCHEDULE THAT SPECIFIES THE AREAS AFFECTED AND DURATIONS. PRIOR TO PROCEEDING WITH WORK, THE PLAN SHALL BE APPROVED BY THE BUILDING OWNER, HCAI COMPLIANCE OFFICER AND CALIFORNIA DEPARTMENT OF PUBLIC HEALTH, LICENSING AND CERTIFICATION DIVISION.

SINGLE LINE FULL BUILDING OPTION 2 - 600 AMP 3 PHASE 4 WIRE

DATE	REVISION
10/12/21	FINAL

NO:

FB2-6-3

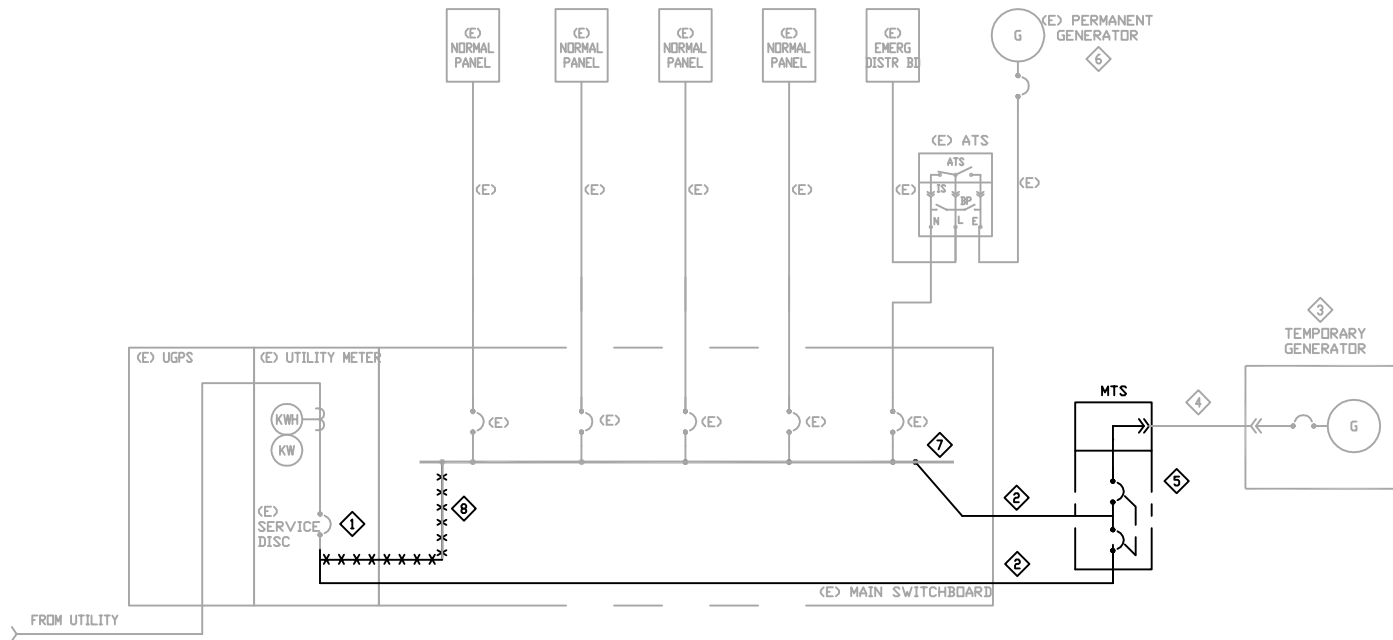

SHEET NOTES:

- ① EXISTING SERVICE DISCONNECT CIRCUIT BREAKER OR SWITCH.
- ② FEEDER CONDUCTORS: 3 SETS 2 1/2" C W/ 3 #300 KCMIL CU & 1 # 1/0 CU GND EA
- ③ TEMPORARY GENERATOR: MIN RATING 200 KW.
- ④ TEMPORARY FEEDER. SUPPLIED BY VENDOR OF TEMPORARY GENERATOR.
- ⑤ MANUAL TRANSFER SWITCH (MTS) :
 - A. 800 AMP 80% RATED BREAKERS.
 - B. 120/240 VOLTS 1 PHASE 3 WIRE TO MATCH (E) SERVICE. UNSWITCHED NEUTRAL CONNECTION.
 - C. SHALL BE LISTED UL 1008 AND CERTIFIED HCAI OSP-582-10.
 - D. ANCHOR PER DRAWING S-1.
- ⑥ EXISTING PERMANENT GENERATOR. SHALL REMAIN OPERATIONAL AT ALL TIMES.
- ⑦ BUS TAP. SHALL BE FIELD LABELED BY A NATIONALLY RECOGNIZED TESTING LABORATORY (NRTL). MINIMIZE TIME THAT TRANSFER SWITCH IS WITHOUT NORMAL POWER. PROVIDE TEMPORARY GENERATOR AS NORMAL SOURCE UNLESS APPROVED BY HCAI COMPLIANCE OFFICER.
- ⑧ REMOVE CONNECTION BETWEEN SERVICE DISCONNECT AND BUS. PROVIDE LUGS ON BREAKER, MINIMIZE TIME THAT TRANSFER SWITCH IS WITHOUT NORMAL POWER. PROVIDE TEMPORARY GENERATOR AS NORMAL SOURCE UNLESS APPROVED BY HCAI COMPLIANCE OFFICER.

SEQUENCE:

CEC 517.41 REQUIRES TWO INDEPENDENT SOURCES OF POWER FOR THE ESSENTIAL ELECTRICAL SYSTEM AT ALL TIMES.

THE WORK SHOWN WILL DISABLE THE NORMAL POWER (UTILITY) FOR SOME PERIOD OF TIME. THE DURATION CAN BE MINIMIZED BY CAREFUL PLANNING, WHICH MAY INCLUDE THE NEED FOR A TEMPORARY GENERATOR.

THE CONTRACTOR SHALL PREPARE A PATIENT IMPACT REPORT AND SCHEDULE THAT SPECIFIES THE AREAS AFFECTED AND DURATIONS. PRIOR TO PROCEEDING WITH WORK, THE PLAN SHALL BE APPROVED BY THE BUILDING OWNER, HCAI COMPLIANCE OFFICER AND CALIFORNIA DEPARTMENT OF PUBLIC HEALTH, LICENSING AND CERTIFICATION DIVISION.

SINGLE LINE FULL BUILDING OPTION 2 - 800 AMP 1 PHASE 3 WIRE

DATE	REVISION
10/12/21	FINAL

NO:

FB2-8-1

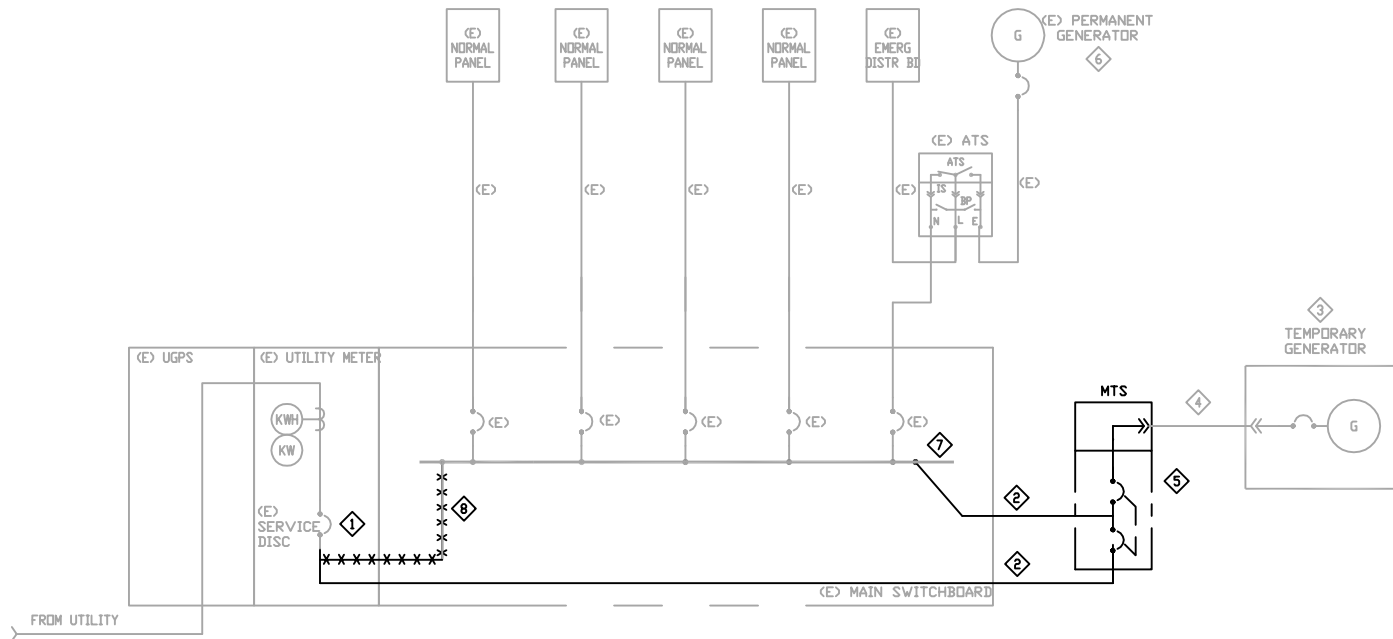

SHEET NOTES:

- ① EXISTING SERVICE DISCONNECT CIRCUIT BREAKER OR SWITCH.
- ② FEEDER CONDUCTORS: 3 SETS 3" C W/ 4 #300 KCMIL CU & 1 # 1/0 CU GND EA
- ③ TEMPORARY GENERATOR: MIN RATING 350 KW.
- ④ TEMPORARY FEEDER. SUPPLIED BY VENDOR OF TEMPORARY GENERATOR.
- ⑤ MANUAL TRANSFER SWITCH (MTS) :
 - A. 800 AMP 80% RATED BREAKERS.
 - B. 120/240 OR 208Y/120 VOLTS 3 PHASE 4 WIRE TO MATCH (E) SERVICE. UNSWITCHED NEUTRAL CONNECTION.
 - C. SHALL BE LISTED UL 1008 AND CERTIFIED HCAI OSP-582-10.
 - D. ANCHOR PER DRAWING S-1.
- ⑥ EXISTING PERMANENT GENERATOR. SHALL REMAIN OPERATIONAL AT ALL TIMES.
- ⑦ BUS TAP. SHALL BE FIELD LABELED BY A NATIONALLY RECOGNIZED TESTING LABORATORY (NRTL). MINIMIZE TIME THAT TRANSFER SWITCH IS WITHOUT NORMAL POWER. PROVIDE TEMPORARY GENERATOR AS NORMAL SOURCE UNLESS APPROVED BY HCAI COMPLIANCE OFFICER.
- ⑧ REMOVE CONNECTION BETWEEN SERVICE DISCONNECT AND BUS. PROVIDE LUGS ON BREAKER, MINIMIZE TIME THAT TRANSFER SWITCH IS WITHOUT NORMAL POWER. PROVIDE TEMPORARY GENERATOR AS NORMAL SOURCE UNLESS APPROVED BY HCAI COMPLIANCE OFFICER.

SEQUENCE:

CEC 517.41 REQUIRES TWO INDEPENDENT SOURCES OF POWER FOR THE ESSENTIAL ELECTRICAL SYSTEM AT ALL TIMES.

THE WORK SHOWN WILL DISABLE THE NORMAL POWER (UTILITY) FOR SOME PERIOD OF TIME. THE DURATION CAN BE MINIMIZED BY CAREFUL PLANNING, WHICH MAY INCLUDE THE NEED FOR A TEMPORARY GENERATOR.

THE CONTRACTOR SHALL PREPARE A PATIENT IMPACT REPORT AND SCHEDULE THAT SPECIFIES THE AREAS AFFECTED AND DURATIONS. PRIOR TO PROCEEDING WITH WORK, THE PLAN SHALL BE APPROVED BY THE BUILDING OWNER, HCAI COMPLIANCE OFFICER AND CALIFORNIA DEPARTMENT OF PUBLIC HEALTH, LICENSING AND CERTIFICATION DIVISION.

SINGLE LINE FULL BUILDING OPTION 2 - 800 AMP 3 PHASE 4 WIRE

DATE	REVISION
10/12/21	FINAL

NO:

FB2-8-3

$\frac{5}{8}$ " DIA BOLT WITH
 B202-1D SQUARE WASHER
 $\frac{3}{4}$ " FLAT WASHER
 $\frac{3}{4}$ " LOCK WASHER
 N255 SPRING NUT
 4 LOCATIONS AS INDICATED

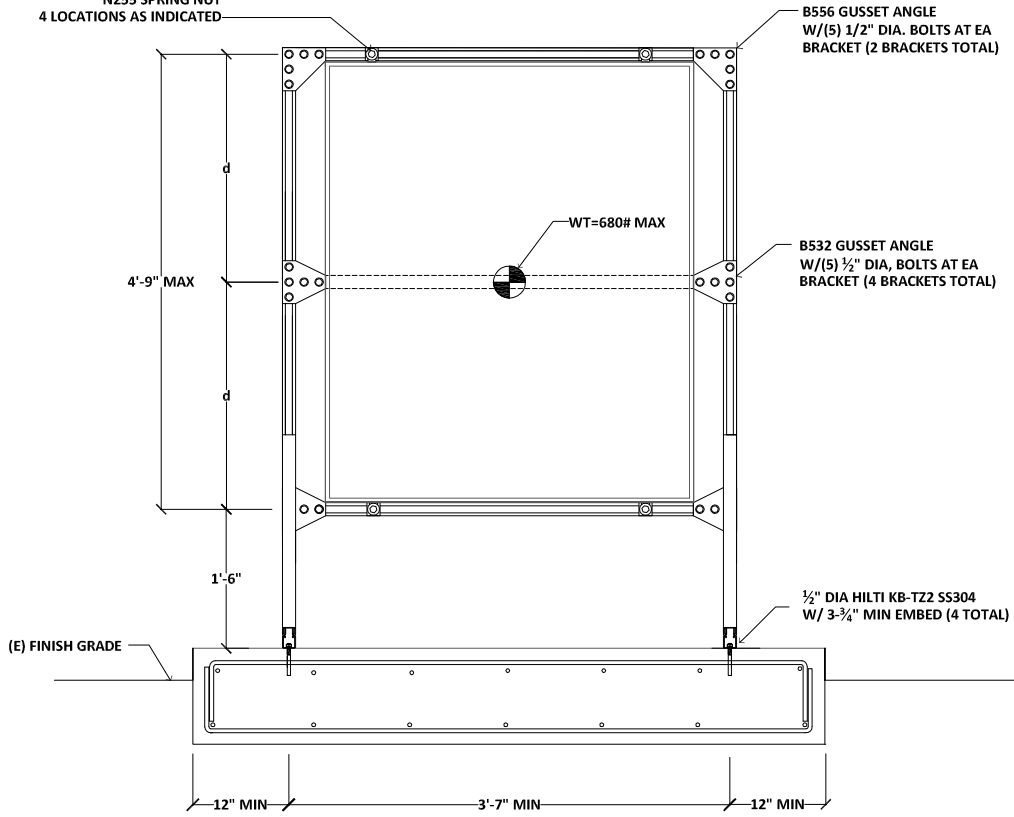

FRONT ELEVATION

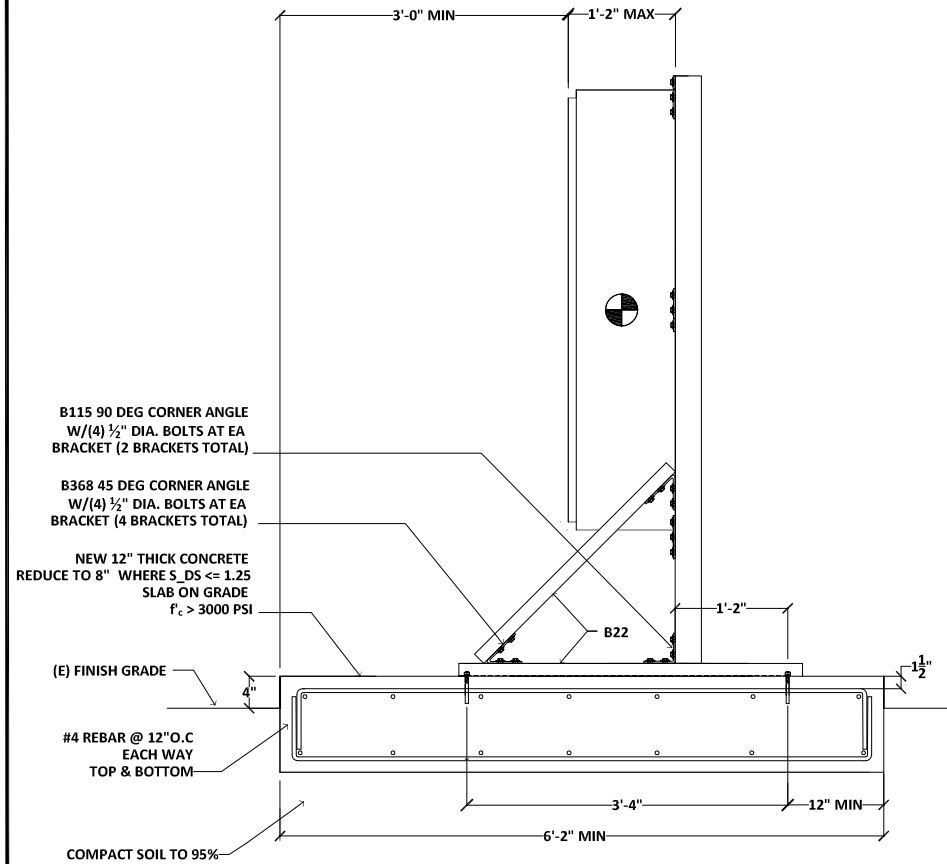

SIDE ELEVATION

1. CHANNEL MATERIAL BLINE 12 GA HOT DIPPED GALVANIZED. B11 UNLESS OTHERWISE NOTED.
2. ALL BRACKETS TO HAVE ELECTROPLATED ZINC FINISH.
3. ALL HARDWARE TO BE ZINC PLATED.
4. ATTACHMENT TO B22 CHANNEL: $\frac{1}{2}$ " DIA BOLT, $\frac{1}{2}$ " LOCK WASHER, N225 CHANNEL NUT.
5. ATTACHMENT TO B11 CHANNEL: $\frac{1}{2}$ " DIA BOLT, $\frac{1}{2}$ " LOCKWASHER, N725 CHANNEL NUT, UNLESS OTHERWISE NOTED.
6. TORQUE ALL CHANNEL BOLTS TO 50 FT-LBS.
7. BOLTS SHALL BE HEX HEAD MACHINE BOLTS CONFORMING TO THE REQUIREMENTS OF ASTM A307, SAEJ429, OR ASTM A563.

ANCHORAGE DETAIL MANUAL TRANSFER SWITCH / DOCKING STATION

DATE	REVISION
10/12/21	FINAL

NO:

S-1

Specifications

Codes

All work shall be performed in accordance with the following codes:

All Applications Submitted on or after January 1, 2020	
2019	California Administrative Code (CAC) Part 1, Title 24, California Code of Regulations (CCR)
2019	California Building Code (CBC) Part 2, Title 24, CCR <i>Based on the 2018 International Building Code (IBC)</i>
2019	California Electrical Code (CEC) Part 3, Title 24, CCR <i>Based on the 2017 National Electrical Code (NEC)</i>
2019	California Mechanical Code (CMC) Part 4, Title 24, CCR <i>Based on the 2018 Uniform Mechanical Code (UMC)</i>
2019	California Plumbing Code (CPC) Part 5, Title 24, CCR <i>Based on the 2018 Uniform Plumbing Code (UPC)</i>
2019	California Energy Code (CEC) Part 6, Title 24, CCR
2019	California Historical Building Code (CHBC) Part 8, Title 24, CCR
2019	California Fire Code (CFC) Part 9, Title 24, CCR <i>Based on the 2015 International Fire Code (IFC)</i>
2019	California Existing Building Code (CEBC) Part 10, Title 24, CCR <i>Based on the 2018 International Building Code</i>
2019	California Green Building Standards Code (CALGreen) Part 11, Title 24, CCR
2019	California Referenced Standards Code (CRSC) Part 12, Title 24, CCR

Listing

All materials and equipment shall be new and shall be listed by Underwriters Laboratories (UL) and bear their label, or listed, labeled or certified by a Nationally Recognize Testing Laboratory where UL does not have a listing.

Conduit

Conduit shall be galvanized steel rigid metal (RMC). Use fitting as required for proper installation. Use UL listed watertight hubs where installation is subject to weather. Running threads are not permitted.

EMT may be used in dry concealed locations (stud walls, ceiling spaces and where exposed above 8' and not subject to mechanical damage). Connectors shall be watertight compression type.

Support and bracing of all conduits to be installed in accordance with one of the following pre-approved seismic bracing and support systems:

OPM-0295-13 Unistrut Seismic Bracing / Strut & Fittings

OPM-0052-13 B-Line / Tolco Seismic Restraint for Suspended Utilities

Conductors

All conductors shall be copper, #12 AWG minimum. Insulation shall be color-coded thermoplastic with a 600 volt rating. Sizes #10 and larger shall be stranded, #12 and smaller shall be solid. Type THHN / THWN. Wiring design is based on 75 deg C conductors.

All switches, circuit breakers and other equipment as specified shall have termination provisions listed and identified for 75 deg C conductors and conduits are sized based on 75 deg C copper type THHN / THWN.

Manual Transfer Switch

Manual transfer switch shall include two circuit breakers with the number of poles specified on the drawings. Circuit breakers shall be rated 208/240 VAC with an interrupting rating of 65,000 kAIC. Breaker shall be molded case, listed UL 489. Breakers shall be interlocked to prevent paralleling of sources.

Generator connection shall be color-coded 400 amp camlock-style male connectors, listed UL 1691. Access to the generator connection compartment shall require both circuit breakers to be in the "OFF" position.

Enclosure shall be gasketed and rated NEMA 3R. Door shall be hinged and have provisions to be padlocked. Dead front construction shall be provided. A lockable handle cover shall be provided to prevent unauthorized operation. A hinged access plate shall be provided to secure the cable entry compartment when not in use.

Weight and dimensions shall meet the limits shown on the anchorage detail provided with the expedited permit documents.

Where indicated, manual transfer switches shall be configured for the use specified in CEC 700.3(f).

Manual transfer switch shall be listed UL 1008 and have special seismic certification under OSHPD OSP 582-10.

Generator Docking Station

Generator docking station shall include a 3-pole molded circuit breaker rated 208/240 VAC with an interrupting rating of 65,000 kAIC. Breaker shall be listed UL 489 and shall be capable of Kirk-key interlock.

Generator connection shall be color-coded 400 amp camlock-style male connectors, listed UL 1691.

Enclosure shall be gasketed and rated NEMA 3R. Door shall be hinged and have provisions to be padlocked. Dead front construction shall be provided. A lockable handle cover shall be provided to prevent unauthorized operation. A hinged access plate shall be provided to secure the cable entry compartment when not in use.

Weight and dimensions shall meet the limits shown on the anchorage detail provided with the expedited permit documents.

Generator docking station shall be listed UL 1008.

Concrete

All concrete shall have a minimum ultimate compressive strength of 3000 psi at 28 days. All concrete shall be regular weight.

All concrete shall comply with CBC Chapter 19 and ACI 318-14 and the latest edition of ACI Manual of Concrete Practice.

Special Inspection (as required or specified) shall conform to CBC Chapter 17.

Cement shall be Portland cement type I or II and shall conform to ASTM C150.

Aggregates shall conform to ASTM C33.

Water shall conform to ASTM C1602.

Reinforcing steel shall be deformed intermediate grade bars conforming to ASTM A616. Grade ($F_y = 60$ ksi).

Utility Interruptions

The facility is in continuous operation 24 hours per day, 7 days per week. All utility interruptions shall be reviewed, approved, and coordinated by the facility representative not less than 48 hours in advance. It shall be the contractor's responsibility to provide temporary power facilities and connections for all feeders, branch circuits, or signal and communications systems being disconnected in order to maintain systems in operation.

Warranty

The contractor shall provide a written warranty covering all equipment, materials, and labor for a period of not less than 1 year from the date of acceptance by the facility.

System No. W-L-1001 *continued*

Through Penetrations

Metallic Pipes

10000 Series

Gypsum

W/L

3. **Fill, Void or Cavity Material* – Caulk or Sealant** – Min 5/8, 1-1/4, 1-7/8 and 2-1/2 in. (16, 32, 48 and 64 mm) thickness of caulk for 1, 2, 3 and 4 hr rated assemblies, respectively, applied within annulus, flush with both surfaces of wall. Min 1/4 in. (6 mm) diam bead of caulk applied to gypsum board/penetrant interface at point contact location on both sides of wall. The hourly F Rating of the firestop system is dependent upon the hourly fire rating of the wall assembly in which it is installed, as shown in the following table. The hourly T Rating of the firestop system is dependent upon the type or size of the pipe or conduit and the hourly fire rating of the wall assembly in which it is installed, as tabulated below:

Max Pipe or Conduit Diam In. (mm)	F Rating Hr	T Rating Hr
1 (25)	1 or 2	0+, 1 or 2
1 (25)	3 or 4	3 or 4
4 (102)	1 or 2	0
6 (152)	3 or 4	0
12 (305)	1 or 2	0

+When copper pipe is used, T Rating is 0 hr.

3M COMPANY – CP 25WB+ caulk or FB-3000 WT sealant,

*Bearing the UL Classification Marking

Test Procedure

Full Building Connection Option 1 (Single Breaker Docking Station)

1.	OSHPD Compliance Officer has been notified of the planned test.	<input type="checkbox"/>
2.	Install the temporary generator as specified in the "Installation of Temporary Generator" instructions.	<input type="checkbox"/>
3.	Verify the presence and accuracy of all signage required under this project.	<input type="checkbox"/>
4.	Verify the circuit breaker at the generator docking station is in the "OPEN" position.	<input type="checkbox"/>
5.	At the generator control panel, start the generator.	<input type="checkbox"/>
6.	Close the disconnect switch/ circuit breaker at the temporary generator.	<input type="checkbox"/>
7.	At the generator docking station, verify that the voltage of the normal source and temporary generator match. Additionally, for 3 phase installations only, verify the rotation of the normal source and temporary generator match.	<input type="checkbox"/>
8.	Open the service disconnect switch and remove the interlock key.	<input type="checkbox"/>
9.	Verify that the service disconnect switch will not close when the interlock key has been removed.	<input type="checkbox"/>
10.	Verify that the circuit breaker at the generator docking station will not close when the interlock key is not present.	<input type="checkbox"/>
11.	Close the circuit breaker on the generator docking station using the interlock key.	<input type="checkbox"/>
12.	Verify the generator takes the building load and there are no generator malfunctions.	<input type="checkbox"/>
13.	Operate the building on the backup generator for 90 minutes. Verify there are no issues.	<input type="checkbox"/>
14.	Open the circuit breaker on the generator docking station and remove the interlock key.	<input type="checkbox"/>
15.	Close the service disconnect switch using the interlock key.	<input type="checkbox"/>

16. Verify normal power is restored to the building.	<input type="checkbox"/>
17. Allow the generator to continue running 5 minutes	<input type="checkbox"/>
18. Shut down the temporary generator.	<input type="checkbox"/>

Test Procedure

Full Building Connection Option 2 (Dual Breaker MTS)

1.	OSHPD Compliance Officer has been notified of the planned test.	<input type="checkbox"/>
2.	Install the temporary generator as specified in the "Installation of Temporary Generator" instructions.	<input type="checkbox"/>
3.	Verify the presence and accuracy of all signage required under this project.	<input type="checkbox"/>
4.	Open the GENERATOR circuit breaker on the Manual Transfer Switch (MTS)	<input type="checkbox"/>
5.	Verify the UTILITY circuit breaker on the MTS is closed.	<input type="checkbox"/>
6.	Start the generator set by using the generator control panel.	<input type="checkbox"/>
7.	Close the disconnect switch / circuit breaker at the temporary generator.	<input type="checkbox"/>
8.	At the MTS, verify that the voltage of the service and temporary generator match. Additionally, for 3 phase installations only, verify the rotation of the service and temporary generator match.	<input type="checkbox"/>
9.	Open the electrical utility service disconnect switch.	<input type="checkbox"/>
10.	Verify that the GENERATOR circuit breaker on the MTS cannot be closed.	<input type="checkbox"/>
11.	Open the UTILITY circuit breaker on the MTS.	<input type="checkbox"/>
12.	Close the GENERATOR circuit breaker on the MTS.	<input type="checkbox"/>
13.	Verify generator takes the building load and there are no generator malfunctions.	<input type="checkbox"/>
14.	Operate the building on the temporary generator for 90 minutes. Verify there are no issues.	<input type="checkbox"/>
15.	Open the GENERATOR circuit breaker on the MTS.	<input type="checkbox"/>
16.	Close the UTILITY breaker on the on the MTS	<input type="checkbox"/>

17. Close the electrical utility service disconnect switch	<input type="checkbox"/>
18. Verify normal power is restored to the building.	<input type="checkbox"/>
19. Open the generator disconnect switch / circuit breaker on the temporary generator.	<input type="checkbox"/>
20. Allow the generator to continue running 5 minutes	<input type="checkbox"/>
21. Shut down the temporary generator.	<input type="checkbox"/>

Installation of Temporary Generator

		Compliance		
		Yes	No	NA
1.	The temporary generator tires are blocked.	<input type="checkbox"/>	<input type="checkbox"/>	
2.	The temporary generator is protected from physical damage and tampering by fencing and/or k-rails.	<input type="checkbox"/>	<input type="checkbox"/>	
2.	If the generator will be in place for more than 30 DAYS, it is restrained in accordance with the detail S2.	<input type="checkbox"/>	<input type="checkbox"/>	<input type="checkbox"/>
3.	The generator output breaker is in the "OPEN" position.	<input type="checkbox"/>	<input type="checkbox"/>	
3.	The cables to be installed are of a type identified in CEC Table 400-4 for hard or extra-hard usage. CEC 590.4(B) One commonly used type is 4/0 Camlock Type W Cables. Note: Diesel locomotive (DLO) cable is commonly proposed for use as temporary conductors. Note that DLO is not a CEC recognized designation. Only cables meeting the above requirements are acceptable	<input type="checkbox"/>	<input type="checkbox"/>	
4.	The cables are installed such that they are protected, supported, not installed directly on the floor or ground, and are not in physical contact with each other. (CEC 590.4(H), (J)).	<input type="checkbox"/>	<input type="checkbox"/>	
5.	The temporary generator's battery charger and jacket/battery heater are connected to the outlets previously identified.	<input type="checkbox"/>	<input type="checkbox"/>	
6.	Where the generator is needed to start upon loss of the utility, the ATS start contacts are connected to the temporary generator. (This is needed only when backing up the permanent generator)	<input type="checkbox"/>	<input type="checkbox"/>	
7.	Where the generator is backing up the permanent emergency generator, the remote annunciator is installed in the building. (NFPA 110 5.6.6)	<input type="checkbox"/>	<input type="checkbox"/>	
8.	Where the generator is backing up the permanent emergency generator and the generator is a separately derived system, the two ground rods are connected to the ground bus of the temporary generator.	<input type="checkbox"/>	<input type="checkbox"/>	
9.	The work will be performed by an electrical contractor licensed in the State of California.	<input type="checkbox"/>	<input type="checkbox"/>	

Testing, Inspection and Observation Program
2019 California Building Standards Code – OSHPD 2

This program is prepared and submitted for an OSHPD 2 projects. OSHPD 2 projects are limited to construction and remodel projects for, skilled nursing facilities and/or intermediate-care facilities of Type V, wood or light steel-frame construction.

SECTION A		PROJECT INFORMATION	
Facility #:	Facility Name:	Project #:	Sub #:
Street Address:			
City:	County:		
Record Name (Scope of Project):	Install Connection for Temp Generator - Full Building		
Abbreviations: CAC: California Administrative Code AAMA: American Architectural Manufacturers Association CBC: California Building Code NFPA: National Fire Protection Association CEC: California Electrical Code FM: FM Approval Standards CMC: California Mechanical Code DPOR: Design Professional of Record			
			Version: R03.7.2

Testing, Inspection and Observation Program
2019 California Building Standards Code – OSHPD 2

SECTION B		NOTE: Approved agencies, individuals, and all changes to the TIO program shall be identified, evaluated by the DPOR and approved by OSHPD prior to proceeding with the related work.			
Facility #:		Facility Name:		Project #:	
DURING CONSTRUCTION DOCUMENT			DURING CONSTRUCTION		
Index #	REQUIRED (Select)	TESTS	RESPONSIBLE APPROVED AGENCY AND/OR INDIVIDUAL	COMPLIANCE VERIFICATION BY IOR (Initial/Date)	OSHPD/FDD USE (Initial/Date)
STRUCTURAL TESTS					
Foundation					
B-F2	X	Soil fill CBC 1705.6 Compaction test			DSE:
Concrete					
B-C1	X	Concrete CBC 1705.3, 1903.6 & 1910.1; ACI-318 1.9.1 & 26.4 Cementitious materials			DSE:
B-C2	X	Concrete CBC 1705.3, 1903.5; ACI-318 1.9.1 & 26.4 Aggregates/Reactive aggregates			DSE:
B-C3	X	Concrete CBC 1705.3, ACI-318 26.4.1.3, ASTM C1602 Water			DSE:
B-C4	X	Concrete CBC 1705.3 & 1909.3.7; ACI-318 26.12.2.1(a) Strength test			DSE:
B-C5	X	Concrete CBC 1705.3 & 1910.2 & ACI-318 20.2, 25.4.5.1 & 26.6.1.2 Metal reinforcement (including welded wire fabric and headed rebar)			DSE:
B-C14	X	Post-installed anchors CBC 1901.3.4 Installation verification test			DSE:
ELECTRICAL TESTS					
B-E13	X	Torque Electrical Connections CEC 110.3(B) & 110.14(D)			CO:
B-E20	X	Final Test - Full Building Connection			CO:
B-E21	X	Signage Verification - Full Building			

Testing, Inspection and Observation Program
2019 California Building Standards Code – OSHPD 2

SECTION C			NOTE: Approved agencies, individuals, and all changes to the TIO program shall be identified, evaluated by the DPOR and approved by OSHPD prior to proceeding with the related work.		
Facility #:		Facility Name:		Project #:	
DURING CONSTRUCTION DOCUMENT SUBMITTAL			DURING CONSTRUCTION		
Index #	REQUIRED (Select)	ON-SITE SPECIAL INSPECTIONS	RESPONSIBLE APPROVED AGENCY AND/OR INDIVIDUAL (IDENTIFY SPECIAL INSPECTOR)	COMPLIANCE VERIFICATION BY IOR (Initial/Date)	OSHPD/FDD USE (Initial/Date)
STRUCTURAL SPECIAL INSPECTIONS					
Concrete					
C-C1	X	Concrete CBC 1705.3; ACI-318 26.5.2 & 26.13 Placement of concrete			DSE:
C-C4	X	Concrete CBC 1705.3; ACI-318 26.13 Reinforcing steel & prestressing steel			DSE:
C-C5	X	Concrete CBC 1705.3 CIP & Post-installed anchors			DSE:
FIRE PROTECTION SPECIAL INSPECTIONS					
C-FP3	X	Penetration firestops CBC 1705.17.1 Penetration firestop systems that are tested and listed			FLSO:

Testing, Inspection and Observation Program
2019 California Building Standards Code – OSHPD 2

SECTION E		REQUIRED COMPLIANCE FORMS				
Facility #:		Facility Name:		Project #:		Sub #:
DURING CONSTRUCTION DOCUMENT SUBMITTAL			DURING CONSTRUCTION			
FORM #	REQUIRED (Select)	DOCUMENT NAME	RESPONSIBLE DESIGNER OR INSTALLING CONTRACTOR	COMPLIANCE VERIFICATION BY IOR (Initial/Date)	OSHPD/FDD USE (Initial/Date)	

Testing, Inspection and Observation Program
2019 California Building Standards Code – OSHPD 2

SECTION F		CONSTRUCTION VERIFICATION												
Facility #:	Facility Name:							Project #:			Sub #:			
VERIFIED CONSTRUCTION INSPECTION AND OBSERVATION REPORTING														
REFERENCE NUMBER	PROJECT MILESTONE OR INTERVAL	VERIFIED COMPLIANCE REPORT REQUIRED AS INDICATED (Form OSH-FD-123) (See "PERSONAL KNOWLEDGE" as defined in California Administrative Code, Section 7-151)											FOR OSHPD USE ONLY	
		GEOR	AOR	SEOR	MEOR	EEOR	CONT	IOR	SP INSP	TEST LAB	OSHPD FDD			
	Substantial Compliance (Remodel, Renovations, Maintenance projects, Equipment Replacement)													
	Certificate of Occupancy (New Buildings, Additions, Changes in Occupancy)													
	Construction Final						X	X	X					
ABBREVIATIONS:		GEOR - Geotechnical Engineer of Record				AOR - Architect of Record				SEOR - Structural Engineer of Record				
		MEOR - Mechanical Engineer of Record				EEOR - Electrical Engineer of Record				CONT O/B - Contractor or Owner/Builder				
		SP. INSP - Special Inspector				IOR - Inspector of Record				Test Lab – Engr. For the approved agency				

Testing, Inspection and Observation Program

2019 California Building Standards Code – OSHPD 2

SECTION G	Inspector of Record (IOR) Responsibility		
Facility #:	Facility Name:	Project #:	Sub #:
This Section only required when more than one IOR will share responsibility on the project.			
<p>INSPECTOR OF RECORD RESPONSIBILITIES. Per CAC 7-145: "The Inspector shall have personal knowledge, obtained by continuous inspection of all work of construction in all stages of its progress to ensure that the work is in accordance with the approved construction documents." This includes applicable Codes, Referenced Standards, Listings and Manufacturer's Installation Instructions applicable to the work shown in the approved construction documents. If a project has more than one inspector of record, the distribution of responsibilities for the work shall be clearly identified for each IOR per CAC 7-141(f). One IOR shall be designated as the 'lead' IOR per CAC 7-144(b). One IOR shall be assigned responsibility for "all other work" to make sure responsibility for the inspection of every part of the work is assigned.</p>			
INSPECTOR OF RECORD CAC 7-141, 7-145 & 7-151	SCOPE OF INSPECTION		PERFORMED OFF-SITE

Testing, Inspection and Observation Program
2019 California Building Standards Code – OSHPD 2

SECTION H		PLAN REVIEW APPROVAL	
Facility #:	Facility Name:	Project #:	Sub #:
NOTE: When a structural engineer has been delegated responsibility for a portion of this project his or her signature is also required. For testing, Inspection and Observation Program Instructions visit: https://oshpd.ca.gov/construction-finance/resources/forms-applications-reminder-lists/#TIO			
Submitted By			
I have reviewed the approved construction documents for this project and all tests and special inspections required by Code are marked as "required" on this form.			
_____ Architect/Engineer of Record (Print Name)	_____ Architect/Engineer of Record (Signature)	_____ Date	
_____ Structural Engineer of Record (Print Name)	_____ Structural Engineer of Record (Signature)	_____ Date	
FOR OSHPD USE			
OSHPD Plan Approval:			
		<input type="checkbox"/> APPROVED <input type="checkbox"/> APPROVED WITH COMMENTS <input type="checkbox"/> DENIED	
_____ Signature	_____ Date		
Comments (If AC or D is checked the following comments shall be resolved by the designer prior to proceeding with the related construction):			