



2020 West El Camino Avenue, Suite 800  
Sacramento, CA 95833  
hcai.ca.gov



## Hospital Building Safety Board Full Board Meeting

AGENDA  
August 15, 2024  
10:00 a.m. – 4:00 p.m.

The Board may not discuss or act on any matter raised during the public comment section that is not included on this agenda, except to place the matter on a future meeting agenda. (Government Code §§ 11125, 11125.7, subd. (a).)

### Location:

[355 South Grand Avenue, Conference Room 2000, Los Angeles, CA 90071](#)

[Teams Meeting Access](#); Meeting ID: 240 506 952 578; Passcode: kNYgoP

Call in: (916) 535-0978; Phone Conference ID: 481 008 555#

- Item #1 Call to Order and Welcome  
*Facilitator: Louise Belair, PE, LEED AP, Senior Vice President, tk1sc; Board Chair (or designee)*
- Item #2 Roll Call and Meeting Advisories/Expectations
- Determination of Quorum
  - Conduct of Meeting
- Facilitator: Veronica M. Yuke, Manager, HCAI; Executive Director (or designee)*
- Item #3 Department of Health Care Access and Information (HCAI) Update
- Swearing-in Ceremony for new HBSB member:
    - Carl Newth, PE, CBO, LEED AP, Local Building Official Member Representative
  - Recognition of outgoing Public Member Representative, David Bliss, MD, and Dr. Bliss' new appointment as a Director-Appointed Ex-Officio Member
  - Acknowledgment of second-term appointment of James O. Malley, Structural Engineer Member Representative
  - HCAI Update
  - Discussion and public input
- Facilitator: Elizabeth Landsberg, Director, HCAI (or designee)*

Item #1

Call to Order and Welcome

*Facilitator: Louise Belair, PE, LEED AP, Senior Vice President, tk1sc;*

*Board Chair (or designee)*



Item #2 Roll Call and Meeting Advisories/Expectations

- Determination of Quorum
- Conduct of Meeting

*Facilitator: Veronica M. Yuke, Manager, HCAI; Executive Director (or designee)*

### Item #3

#### Department of Health Care Access and Information (HCAI) Update

- Swearing-in Ceremony for new HBSB member:
  - Carl Newth, PE, CBO, LEED AP, Local Building Official  
Member Representative
- Recognition of outgoing Public Member Representative, David Bliss, MD, and Dr. Bliss' new appointment as a Director-Appointed Ex-Officio Member
- Acknowledgment of second-term appointment of James O. Malley, Structural Engineer Member Representative
- HCAI Update
- Discussion and public input

*Facilitator: Elizabeth Landsberg, Director, HCAI (or designee)*

## Item #4

### Nominations for HBSB Chair and Vice-Chair Kick Off

- Review of the nomination process for HBSB Chair and Vice-Chair
- Nominating Committee presents slate of candidates
- Committee invites nominations from the floor
- Discussion and public input

*Facilitators: Michael Foulkes, Director, State and Local Government Affairs, Apple Inc.; and Michael O'Connor, Principal, Nichols, Melburg & Rossetto; Nominating Committee (or designees)*

Item #5

Overview and approval of the April 18, 2024, draft Meeting Report/Minutes

- Discussion and public input

*Facilitator: Louise Belair (or designee)*

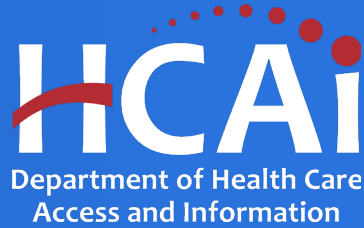

# Hospital Building Safety Board

Report by  
Louise Belair, Board Chair

## BOARD MEMBERS:

James O. Malley – Board Vice-Chair

Cody Bartley, David Bliss, Janice Cheung, Jennifer Cox, Michael Davis, Gary Dunger, Teresa Endres, Michael Foulkes, John Griffiths, Martin Hudson, Courtney Johnson, Scott Mackey, Farzad Naeim

## DIRECTOR APPOINTED EX-OFFICIO MEMBERS

Bert Hurlbut, Michael O'Connor

## STATUTORY EX-OFFICIO MEMBERS:

Elizabeth Landsberg, HCAI Director; Scott Christman, HCAI Chief Deputy Director; Chris Tokas, OSHPD Deputy Director; Wendy Collins, (Delegate) State Fire Marshall; Kevin Day, Building Standards Commission, Executive Director; Jeremy Lancaster, State Geologist

## HCAI STAFF Present:

Arash Altoontash, Deputy Division Chief, Joe Labrie, Roy Lobo, Mia Marvelli, Jamie Schnick, Ali Sumer, Nanci Timmins, John Gray, HCAI Attorney

## HBSB STAFF Present:

Veronica Yuke, Acting Executive Director, Marcus Palmer, Evett Torres

# MEETING REPORT:

Meeting Date: April 18, 2024

# Meeting Date: 4/18/2024

## OVERVIEW OF TOPICS

- Topic 1: Call to Order and Welcome
  - Louise Belair, Board Chair called the meeting to order.
- Topic 2: Roll Call and Meeting Advisories/Expectations
  - 14 members present. Quorum was established.
  - Veronica Yuke, Acting Executive Director read the public announcement regarding meeting rules and procedures.

# Meeting Date: 4/18/2024

## OVERVIEW OF TOPICS

- Topic 3: HCAI Update – Elizabeth Landsberg, HCAI Director / Scott Christman, HCAI Chief Deputy Director

Ms. Landsberg gave the following update:

- Governor released January budget with \$38 billion deficit.
  - Includes proposals to temporarily borrow from HCAI's fund and delay specific workforce programs.
- HCAI approved loan to Madera Hospital with Hope hospital to re-open in summer of 2024.
- HCAI is developing clinical quality measures to evaluate hospitals' effort regarding health equity approved for inclusion in upcoming regulations.
- OHCA (Office of Healthcare Affordability) will be adopting Alternative Payment Models (APM), primary care spent threshold and workforce stability standards by summer of 2024.



# Meeting Date: 4/18/2024

## OVERVIEW OF TOPICS

- Topic 3: HCAI Update (Continued)
  - Mr. Christman swore in two new HBSB members:
    - Jennifer G. Cox – Public Member Representative
    - Courtney B. Johnson – Engineering Geologist Representative
  - Ms. Landsberg answered a question about behavioral health bond program

# Meeting Date: 4/18/2024

## OVERVIEW OF TOPICS

- Topic 4: Overview and Approval of December 5-6, 2023, Full Board draft Meeting Report/Minutes – Louise Belair, Board Chair
  - Highlights were:
    - Nomination and election of James Malley as Board Vice-Chair to replace Scott Jackson.
    - 50<sup>th</sup> anniversary of the Song-Brown Healthcare Workforce Training Act.
    - 2023 was the 50<sup>th</sup> anniversary of the Alfred E. Alquist Hospital Seismic Safety Act.
    - Review of HCAI Healthcare related bills.
    - Review of HCAI program accomplishments for 2023.
    - Swearing in new HBSB Board members:
      - Janice Cheung, Fire and Life Safety representative
      - Martin B. Hudson, Geotechnical Engineer representative

# Meeting Date: 4/18/2024

## OVERVIEW OF TOPICS

- Topic 4: Overview and Approval of December 5-6, 2023, Full Board draft Meeting Report/Minutes (Continued)
  - Recognition of outgoing HBSB members:
    - Bruce Clark, Engineering Geologist representative
    - Scott Jackson, Fire and Life Safety representative
    - Michelle Lampshire, Public Member representative
    - Marshall Lew, Geotechnical Engineer representative
  - Review and Approval of August 17, 2023 Full Board Meeting report
  - Committee Reports Overview and Approval: Energy Conservation and Management, Education and Outreach, Codes and Processes, Instrumentation, Structural and Nonstructural Regulations and Ad Hoc Board Procedures.
  - Administration of Process for filling Board Vice-Chair vacancy for 2025-2026 term.
  - Review and approval of 2024 committee assignments, goals and schedule.

# Meeting Date: 4/18/2024

## OVERVIEW OF TOPICS

- Topic 4: Overview and Approval of December 5-6, 2023, Full Board draft Meeting Report/Minutes (Continued)
  - OSHPD Update highlights were reviewed.
  - Inspection Services Unit Update highlights were reviewed.
  - Building Standards Unit Update highlights were reviewed.
  - Fire Prevention Unit Update highlights were reviewed.
  - Structural Services Section Update highlights were reviewed.
  - Review of motions.

# Meeting Date: 4/18/2024

## OVERVIEW OF TOPICS

- Topic 5: Ad Hoc Board Procedures Committee – Michael Foulkes, Committee Chair
  - Review of the meeting highlights:
    - Review of the board procedures and the vice chair vacancy procedures
    - No future meeting planned.

# Meeting Date: 4/18/2024

## OVERVIEW OF TOPICS

- Topic 6: Codes and Processes Committee – Michael O’Connor, Committee Chair
  - Overview and Approval of the January 10, 2024, draft meeting report/minutes.  
Highlights were:
    - Proposed amendments to 2025 California Mechanical Code.
    - Proposed amendments to 2025 California Plumbing Code.
  - Overview and Approval of the February 21, 2024, draft meeting report/minutes.  
Highlights were:
    - Proposed amendments to 2025 California Administrative Code.
    - Proposed amendments to 2025 California Building Code, Part 2 Volume 1.
    - Updates to California Mechanical Code proposed code changes.
    - Updates California Plumbing Code proposed code changes.
    - Update on Electronic TIO development / Pre-Approved Details update.

# Meeting Date: 4/18/2024

## OVERVIEW OF TOPICS

- Topic 7: Instrumentation Committee – Jim Malley, Committee Vice-Chair
  - Overview and Approval of January 25, 2024, draft meeting report/minutes.
  - Highlights were:
    - Discussion on issues related to Instrumentation of wood-framed hospital buildings.
    - Selection of candidate wood-framed hospital for HCAI instrumentation.
    - Approval of selected candidate wood framed buildings.

# Meeting Date: 4/18/2024

## OVERVIEW OF TOPICS

- Topic 8: Structural and Non-Structural Regulations Committee – Jim Malley, Committee Chair
  - Overview and Approval of March 6, 2024, draft meeting report/minutes.
  - Highlights were:
    - Proposed amendments to risk category designation of Skilled Nursing and Acute Psychiatric Facilities.
    - Proposed amendments to 2025 California Building Code Title 24 Part 1.
    - Proposed amendments to 2025 California Building Code Title 24 Part 2.
    - Proposed amendments to 2025 California Building Code Title 24 Part 10.



# Meeting Date: 4/18/2024

## OVERVIEW OF TOPICS

- Topic 9: Education and Outreach Committee – Scott Mackey, Committee Chair
  - Overview and Approval of February 8, 2024, draft meeting report/minutes.
  - Highlights were:
    - Review of 2023 committee supported accomplishments
    - Notice of 2024 committee supported presentations
    - Update on the Guide for Working on OSHPD projects – Tips from the Experts
    - Update on the Guide for Planning and Preparing for Disasters
    - Update on PIN 50 – Integrated Review Webinar
    - Update on Offsite Fabrication/Preassembled Components Webinar
    - Discussion on opportunities for educational content, events or programs for 2024

# Meeting Date: 4/18/2024

## OVERVIEW OF TOPICS

- Topic 10: Offsite Fabrication/Preassembled Components Webinar Development Subcommittee –  
Cody Bartley, Committee Chair
  - Overview and Approval of February 28, 2024, draft meeting report/minutes.
  - Highlights were:
    - Update on draft content for Offsite Fabrication/Preassembled Components Webinar
    - Review speaking roles and proposed presenters
    - Agenda for April 24, 2024, meeting was established.

# Meeting Date: 4/18/2024

## OVERVIEW OF TOPICS

- Topic 11: Appoint a Nominating Committee for Chair and Vice-Chair Elections at the August 2024 Full Board Meeting – Louise Belair, Board Chair
  - Michael O'Connor and Michael Foulkes were appointed as the nominating committee for the next chair and vice chair elections.
  - Voting will take place at next full board meeting in August 2024.
  - Clarification on the chair and vice-chair duties.

# Meeting Date: 4/18/2024

## OVERVIEW OF TOPICS

- Topic 12: Office of Statewide Hospital Planning and Development Update - Chris Tokas, OSHPD Deputy Director
  - Report on California Climate Commitment
  - Update on CMS categorical waiver for healthcare microgrid system
  - Design Guide for Planning and Preparing for Disasters is now available on HCAI website; new chapters were added.
  - Design Guide for Working on Projects under OSHPD jurisdiction has been published and available on HCAI website.
  - Overview of January 1, 2024, Seismic Compliance submittals
  - Update on Small and Rural Hospital Relief Program
  - Update on AB 2511 – 96 Hours Emergency Power for SNF’s assessments submitted.

# Meeting Date: 4/18/2024

## OVERVIEW OF TOPICS

- Topic 13: Building Standards Unit Update – Mia Marvelli, Building Standards Unit Supervisor
  - Update on Building Standards Unit role.
  - Update on BSU and State agency coordination
  - Update on collaboration with Mental Health Services Oversight and Accountability Commission.
  - Report on BSU / AIA Central Valley monthly meeting for collaboration on Remodel CAN, Title 24 code changes and Alternate Method of Compliance.

# Meeting Date: 4/18/2024

## OVERVIEW OF TOPICS

- Topic 14: Inspection Service Unit - Joe LaBrie, Inspection Services Unit Supervisor
  - Report on eTIO development activities.
  - Update on ISU certification and recertification exams in April 2024
  - Working on Compliance Officer Academy
  - Review of ISU efforts.
- Topic 15: Fire Prevention Unit Update – Nanci Timmins, Chief Fire Life Safety Officer
  - Report on FPU workload.
  - Report on Training program, recruitment and staff.
  - 2025 proposed code modifications.
  - Review of ICC and SFM collaboration.

# Meeting Date: 4/18/2024

## OVERVIEW OF TOPICS

- Topic 16: Structural Services Section Update – Roy Lobo, Principal Structural Engineer
  - Announcement of upcoming webinar/seminar for AB 1882 for late summer 2024
  - Update on the AB 2190 Extension categories.
  - Review Seismic Compliance Unit webinars
  - Small and Rural Hospital Relief Program update.
  - Overview of the Structural Support Unit programs.
  - Review of proposed changes to 2025 California Building Code, Title 24.

# Meeting Date: 4/18/2024

## OVERVIEW OF TOPICS

- Topic 17: Comments from the public/board members not on this agenda – Louise Belair, Board Chair
  - None.
- Topic 18: Adjournment – Louise Belair, Board Chair
  - Meeting adjourned on April 18, 2024 at approximately 3:06 pm.



# Meeting Date: 4/18/2024

## OVERVIEW OF TOPICS

- Motion 1: The board unanimously voted to approve the December 5-6, 2023 - Full Board meeting draft Report/Minutes as amended with corrections.
- Motion 2: The board unanimously voted to approve the December 5, 2023 – Ad Hoc Board Procedures Committee draft Report/Minutes as presented.
- Motion 3: The board unanimously voted to approve the January 10, 2024 and February 21, 2024 – Code and Processes Committee draft Meeting Reports/Minutes as amended.
- Motion 4: The board unanimously voted to approve the January 25, 2024 – Instrumentation Committee draft Meeting Report/Minutes as amended.
- Motion 5: The board unanimously voted to approve the March 6, 2024 - Structural and Non-Structural Regulations Committee draft Meeting Reports/Minutes as corrected.

# Meeting Date: 4/18/2024

## OVERVIEW OF TOPICS

- Motion 6: The board unanimously voted to approve the February 8, 2024 - Education and Outreach Committee draft Meeting Reports/Minutes as presented.
- Motion 7: The board unanimously voted to approve the February 28, 2024 – Offsite Fabrication/Preassembled Components Webinars Development Subcommittee draft Meeting Report/Minutes as presented.

## NEXT STEPS:

- None discussed

# Meeting Date: 4/18/2024

## OVERVIEW OF TOPICS

- Questions and Answers
- This report requires a MOTION by a Board Member and must be SECONDED by a Board Member for further ACTION.

Item #6

Offsite Fabrication/Preassembled Components Webinar  
Development Subcommittee

- Overview and approval of the following draft Meeting Report/Minutes:
  - March 26, 2024
  - May 8, 2024
  - June 11, 2024
- Discussion and public input

*Facilitator: Cody Bartley, DPR Construction; Subcommittee Chair (or designee)*



# Offsite Fabrication/Preassembled Components Webinar Subcommittee

by

Cody Bartley, CHAIR  
Scott Mackey, VICE CHAIR  
Teresa Endres

## OSHPD STAFF

Hussain Bhatia  
Joe LaBrie  
Mia Marvelli  
AliSumer  
Nanci Timmins

# Offsite Fabrication/Preassembled Components Webinar Subcommittee

## MEETING REPORTS:

- Meeting Date: March 26, 2024
- Meeting Date: May 8, 2024
  - Reschedule from April 24<sup>th</sup>
- Meeting Date: June 11, 2024
- Webinar Date: June 25, 2024



# Meeting Date: **March 26, 2024**

## OVERVIEW OF TOPICS

- **Update on the draft content for Offsite Fabrication/Preassembled Components Webinar**
  - Cody Bartley presented a review of the Feb 28, 2024 meeting minutes
  - Ms. Timmins presented a review of new content that was added to the webinar regarding a section for FLSO considerations.
  - Cody Bartley pointed out editorial comment changes to prefabrication, the TIO and additional examples related to Kaiser Riverside.
  - Mr. Mackey discussed the fit and finish of the presentation and reducing the number of words on the slide. This will occur before the next meeting.
  - Mr. Tannahill requested the latest draft be shared so that feedback could be incorporated.





# Meeting Date: **March 26, 2024**

## OVERVIEW OF TOPICS



- **Review of speaking roles and proposed presenters**
  - Cody Bartley indicated that presenters are identified on the slides
  - Timeline for the slide deck was discussed and confirmed it would be finalized and formatted for presentation ahead of the next meeting
  
- **Agenda for April 24, 2024 was established**
  - Cody Bartley indicated that the purpose of the next meeting would be to conduct dry runs through the webinar and the date was established.

Meeting Date: **April 24, 2024**

- Rescheduled to May 8<sup>th</sup>



Meeting Date: **May 8, 2024**

## OVERVIEW OF TOPICS



- **Update on the draft content for Offsite Fabrication/Preassembled Components Webinar**
  - Cody Bartley presented a review of the March 26, 2024 meeting minutes
  - Reviewed Speaking roles and presenters, discussed reducing slide text
  - Discussion on definitions that were needed to be covered and if prefabrication=preassembly or if terms needed to be distinguished
  - Run through and discussion on slide content to finalize messaging
  - Discussed slide images and that the TIO slide needed to be updated
  - Interested party requested to further expand on how construction and inspections would work for offsite prefabrication.
  - Discussed potential dates for the webinar and duration
  - Established that an additional subcommittee meeting would be needed prior to the webinar due to the number of changes that were made during the meeting

# Meeting Date: June 11, 2024

## OVERVIEW OF TOPICS

- **Update on the draft content for Offsite Fabrication/Preassembled Components Webinar**
  - Cody Bartley presented a review of the May 8, 2024 meeting minutes
  - Discussed emphasis of the webinar being submittal process and inspection process of prefabricated components.
  - Performed dry-run through presentation and slide deck with established speakers
  - Webinar schedule was reviewed and confirmed
  - Use of GoToWebinar software was agreed to and logistics of presentation were discussed
  - Slide images and the use of specific names were discussed, agreed that the final slide deck would remove project specific identification from example images.

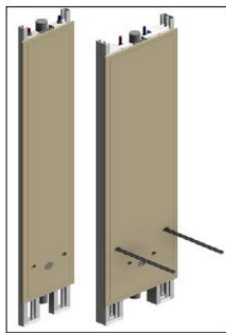
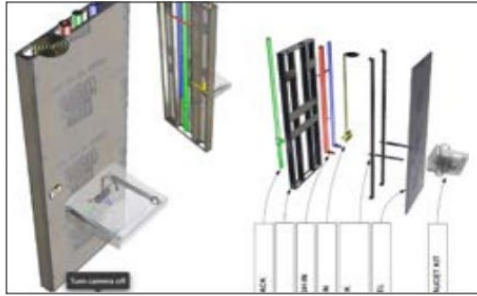

## Meeting Date: **March 26, 2024**

### OVERVIEW OF MOTIONS

- Motion Made and Unanimously voted to approve the Feb 28<sup>th</sup>, 2024 meeting minutes

## Meeting Date: **May 8, 2024**

### OVERVIEW OF MOTIONS

- Motion Made and Unanimously voted to approve the Mar 26<sup>th</sup>, 2024 meeting minutes

## Meeting Date: **June 11, 2024**

### OVERVIEW OF MOTIONS

- Motion Made and Unanimously voted to approve the May 8<sup>th</sup>, 2024 meeting minutes

## **BUILDINGS AS PRODUCTS**

Standardize your real estate portfolio by buildings facilities using a personalized kit-of-parts.

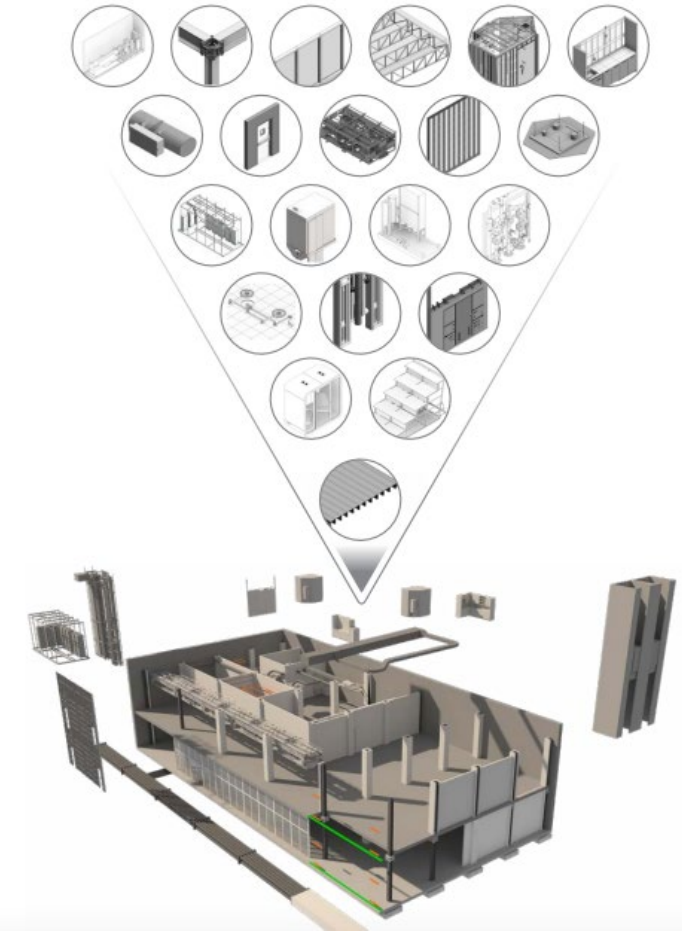

# Preapproved Fabricated Components & Systems Webinar 6/25/24

**632 Registered Attendees**

**393 Logged in Attendees**

**1 Hr Presentation**

**30 Min Q&A**

- **Development of Webinar started in June of 23', Committee met 5 times and had 1 Dry Run to prepare**

## **HBSB COMMITTEE MEMBERS**

**Scott Mackey, CHAIR**  
**Cody Bartley, VICE CHAIR**  
**Teresa Endres**

## **OSHPD STAFF**

**Hussain Bhatia**  
**Alireza Asgari**  
**Cesar Ponce**



Meeting Date: March 26, 2024

Meeting Date: May 8, 2024

Meeting Date: June 11, 2024

Webinar Date: June 28, 2024



## CONCLUSION

- Questions and Answers
- I move to accept the March 26, May 8, and June 11, 2024, meeting reports.



Item #7

Codes and Processes Committee

- Overview and approval of the May 8, draft Meeting Report/Minutes
- Discussion and public input

*Facilitator: Michael O'Connor, Committee Chair (or designee)*



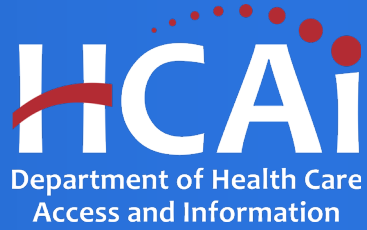

## Codes & Processes Committee

### CODES AND PROCESSES COMMITTEE MEMBERS

MICHAEL O'CONNOR, CHAIR  
TERESA ENDRES, VICE CHAIR  
CODY BARTLEY  
LOUISE BELAIR  
JENNIFER COX  
MICHAEL DAVIS  
GARY DUNGER  
JOHN GRIFFITHS  
SCOTT MACKAY  
JIM MALLEY  
FARZAD NAEIM

### CODES AND PROCESSES CONSULTING MEMBERS

MARK HERSHBERG  
KELLY MARTINEZ  
BELINDA YOUNG

### CODES AND PROCESSES HCAI STAFF

CHRIS TOKAS  
RICHARD TANNAHILL  
ARASH ALTOONTASH  
BRETT BEEKMAN  
LARRY ENRIGHT  
JOE LABRIE  
ROY LOBO  
BOB LYONS  
MIA MARVELLI  
DIANA NAVARRO  
CARL SCHEUERMAN  
JAMIE SCHNICK  
NANCI TIMMINS  
JOHN GRAY

### CODES AND PROCESSES HBSB STAFF

VERONICA YUKE  
MARCUS PALMER  
EVETT TORRES

## MEETING REPORTS:

- Meeting Date: 5/8/2024

**Meeting Date: 5/8/2024**  
**OVERVIEW OF TOPICS - TOPIC 1**

*Title 24*  
*California Building*  
*Standards Code*  
*Update*

**Topic 1 – Triennial Code Cycle Update & Timeline**

Presenter: Mia Marvelli, Architect, Supervisor, HCAI

- Ms. Marvelli provided an update on the 2024 Triennial Code Cycle, highlighting that the 2022 Blue Page supplements took effect on July 1, 2024, and discussed the ongoing rulemaking process for the 2025 edition of Title 24, including recent submissions for various code changes.
- Detailed important dates for public comment periods and upcoming committee meetings, emphasizing coordination with the State Fire Marshal and opportunities for public input.

# Meeting Date: 5/8/2024

## OVERVIEW OF TOPICS - TOPIC 2

### **Topic 2 – 2025 California Building Code, Part 2, Volume 1, Title 24: Proposed Amendments sent to the Office of the State Fire Marshal**

Presenter: Nanci Timmins, Chief Fire and Life Safety Officer, HCAI

Ms. Timmins reviewed the proposed amendments to the 2025 California Building Code, emphasizing alignment with NFPA 101 standards. Key items included:

- Clarifying egress requirements for treatment rooms and atriums
- Reorganization of suite design sections.
- Reinstating NFPA 99 references for electrical systems and maintaining stricter California-specific fire safety measures for cooking facilities in healthcare settings.

The amendments aim to enhance clarity, consistency, and safety compliance in the code.

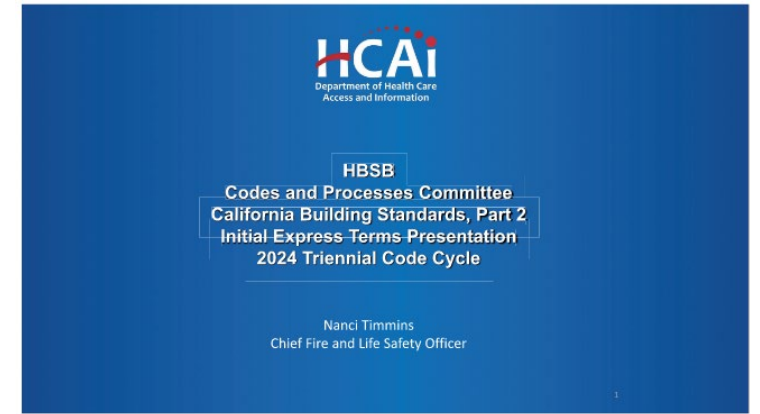

**Meeting Date: 5/8/2024**

## **OVERVIEW OF TOPICS - TOPIC 3**

### **Topic 3 – Update on Electronic Test, Inspection, and Observation (eTIO) Development**

Presenter: Chris Davis, SE, District Structural Engineer, HCAI

Mr. Davis provided an update on the development of the Electronic Test, Inspection, and Observation (eTIO) system, which aims to replace the current paper-based process with a fully digital tool. Key features HCAI is striving for:

- User-friendly interface with visual status indicators
- Detailed summaries for each test and inspection
- Ability to track progress with start and finish dates.

The goal is to streamline project management and ensure all testing and inspections are efficiently documented and accessible online.

**Meeting Date: 5/8/2024**

## **OVERVIEW OF TOPICS - TOPIC 4**

### **Topic 4 – Standard Details Update**

Presenter: Gary Dunger, Executive Director, Design and Construction, Cedars-Sinai Health System; Committee Member

- Mr. Dunger updated the committee on the progress of standard details, noting the addition of a Revit expert to his team for drawing and completing necessary details.
- Gary solicited final detail requirements from the committee, highlighting specific construction and MEP details needing review.
- Presentation of the proposed details will be presented at the next meeting on September 11, 2024 for additional input from committee members.

# Meeting Date: 5/8/2024

## OVERVIEW OF MOTIONS

- No motions were made at this meeting.

**Meeting Dates: 05/08/2024**

## **CONCLUSION**

- Questions and Answers
- I move to accept the May 8, 2024, meeting report



Item #8

Education and Outreach Committee

- Overview and approval of the May 22, 2024, draft Meeting Report/Minutes
- Discussion and public input

*Facilitator: Scott Mackey, AIA, NCARB, APEC, Design Manager, Hensel Phelps; Committee Chair (or designee)*

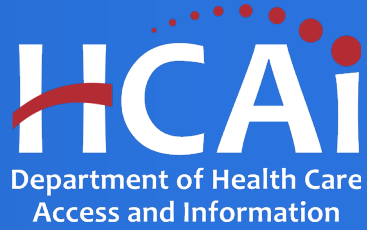

# Education and Outreach Committee

by  
Scott Mackey, CHAIR  
Cody Bartley, VICE CHAIR

## COMMITTEE MEMBERS

Louise Belair  
Janice Cheung  
Michael Davis  
Gary Dunger  
Teresa Endres  
Bert Hurlbut  
Courtney Johnson  
Jim Malley

## CONSULTING MEMBERS

Kelly Martinez  
Bruce Rainey  
Belinda Young  
Bill Zellmer

## OSHPD STAFF

Hussain Bhatia  
Monica Colosi  
Darren Graves  
Joe LaBrie  
Mia Marvelli  
Jamie Schnick  
Nanci Timmins

## MEETING REPORTS:

- **Meeting Date: May 22, 2024**

Meeting Date: **May 22, 2024**

## OVERVIEW OF TOPICS

### Review of 2024 Committee Supported Accomplishments

- Published Design Guides
  - Projects Under OSHPD Jurisdiction – Tips from the Experts
  - Planning & Preparing for Disasters
- Pre-Fabricated & Pre-Assembled Webinar
  - Event hosted on June 25<sup>th</sup>
  - 632 Registrants

Meeting Date: **May 22, 2024**

**OVERVIEW OF TOPICS**

**Update on the Guide for Working on OSHPD Projects –  
Tips from the Experts**

- Mia Marvelli and Paul Coleman presented the final updates to the Guide and announced the Guide has been published along with an advertisement about its availability.

**DESIGN GUIDE FOR  
WORKING ON PROJECTS  
UNDER OSHPD JURISDICTION**



*Tips from the Experts*

Office of Statewide Hospital Planning and Development

April 15, 2024

Version 4.0

**DESIGN GUIDE FOR  
PLANNING AND PREPARING  
FOR DISASTERS**

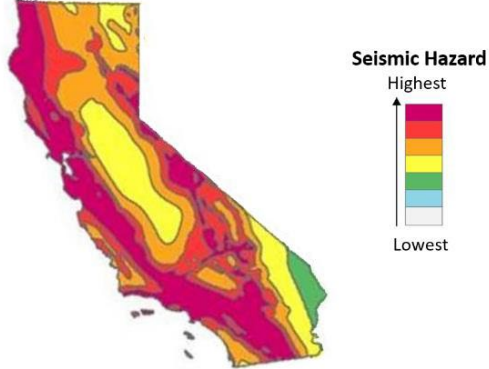

*Best Practices for Emergency  
Planning, Preparation, and Solutions*

Office of Statewide Hospital Planning and Development

March 1, 2024

**Meeting Date: May 22, 2024**  
**OVERVIEW OF TOPICS**

**Update on the Guide for Planning & Preparing for  
Disasters**

- Mia Marvelli and Paul Coleman presented the final updates to the Guide and announced the Guide has been published along with an advertisement about its availability.







Meeting Date: **May 22, 2024**

## OVERVIEW OF TOPICS

### **Update on the Policy Intent Notice (PIN) 50 – Integrated Review Webinar**

- Diana Navarro presented specifics regarding the webinar content: a 1-hour webinar focusing on the client's perspective of the integrated review process.
- Tentative presenters for the webinar would include herself, Gary Dunger and Monica Colosi.
- Event is scheduled for September 25, 2024.



Meeting Date: **May 22, 2024**

## OVERVIEW OF TOPICS

### **Update on the Preapproved Fabricated Components and Systems Webinar**

- Event was held on June 25, 2024.
- There were 632 registered attendees for the event.
- Cody Bartley has already presented details of the event.

Meeting Date: **May 22, 2024**

## OVERVIEW OF TOPICS

### Creation of an “Island Hospital Concept” Facility Example

- Jamie Schnick, Marc Hoffman, David Bliss, and Duc Bui presented the motivations for exploring an island hospital concept.
- Increased need for hospitals to gain control over their utility services.
- Stressing the advantages of the economic benefits, less reliance on single source service providers, and independence from utility reliance.
- Use of microgrids, fuel cells and battery storage systems towards cost savings.
- Subject matter transferred to the Energy Conservation & Management Committee.

Meeting Date: **May 22, 2024**

## OVERVIEW OF TOPICS

### **Report on the creation of a California Administrative Code Training Webinar**

- Monica Colosi and Darren Graves presented the creation of a Construction Administration Proficiency (CAP) program created by the office to improve the understanding and application of the California Administrative Code.
- The Proficiency Certification program would be at no cost to the applicants.
- Examinations are given in-person at both the Sacramento and Los Angeles offices.
- Candidates who pass the exam will be certified and will be listed on the website.







Meeting Date: **May 22, 2024**

## OVERVIEW OF TOPICS

### Discussion on approving American Institute of Architects Continuing Education Units

- Explored the idea of becoming an approved AIA CEU educator.
- Richard Tannahill explained the experience in trying to apply.
- Due to requirements to meet AIA requirements, it was agreed to pass on the pursuit and simply provide certification of attendance for an event.
- Resulted in directing those interested in securing AIA CEU credits to self-report.

Meeting Date: **May 22, 2024**

## OVERVIEW OF TOPICS

### **Discussion on New Opportunities for Educational Content, Events or Programs for 2024**

- Classification of imaging procedures into Class 1, 2 and 3.
- Revisiting the “Inspect to Pass” approach to Field Inspections.
- Formal rollout of OSHPD 6: Chemical Dependency Recovery Hospitals (CDRH)
- New program on “Tips for Working with OSHPD in the Field.”
- Working with photovoltaics, microgrids, and battery systems associated with utility independence from the electrical grid and utility companies.

Meeting Date: **May 22, 2024**

## OVERVIEW OF TOPICS

### **Discussion on New Opportunities for Educational Content, Events or Programs for 2024**

- How to write a Functional Program & Operational Program webinar opportunity.
- Creation of a Design Professional Mentorship Program through HCAI.
- Exploration of how to expand the distribution of materials and announcements to a greater audience = possible creation of a bulletin board on the OSHPD website highlighting the confirmed events in the future.







Meeting Date: **May 22, 2024**

## OVERVIEW OF TOPICS

- **Future Education and Outreach Committee Meeting**
  - September 26, 2024
  - Additional meetings may be added as needed.

Meeting Date: **May 22, 2024**

**OVERVIEW OF MOTIONS**

**No Motions were presented.**

Meeting Date: **May 22, 2024**

**CONCLUSION**

- **Questions and Answers**
- **I move to accept the May 22, 2024, meeting report.**

## Item #9

### Technology and Research Committee

- Overview and approval of the June 20, 2024, draft Meeting Report/Minutes
- Discussion and public input

*Facilitator: Gary Dunger, Executive Director, Design and Construction, Cedars-Sinai Health System; Committee Chair (or designee)*

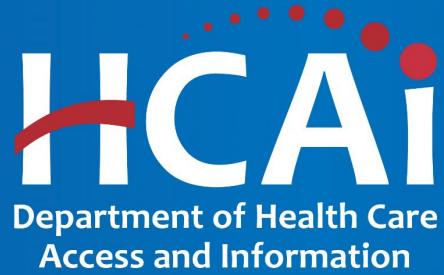

# Technology and Research Committee

by

Gary Dunger, Chair  
Cody Bartley, Vice Chair

**COMMITTEE MEMBERS:**

David Bliss  
Janice Cheung  
Jennifer Cox  
Teresa Endres  
Michael Foulkes  
John Griffiths  
Bert Hurlbut  
Scott Mackey  
Michael O'Connor

**CONSULTING MEMBERS:**

Benjamin Broder  
Eric Johnson  
Belinda Young  
  
OSHPD STAFF  
Hussain Bhatia  
Larry Enright  
Joe LaBrie  
Carl Scheuerman  
Nanci Timmins

# Technology and Research Committee Meeting Report

Meeting Date: Thursday, June 20, 2024  
10:00 a.m. – 4:00 p.m.

# Technology and Research Committee

## Meeting Date: Thursday, June 20, 2024

### OVERVIEW OF TOPICS

- Topic 1

**Presentation: Cedars-Sinai Marina Del Rey Replacement Hospital Technology Program**

**Presenter:** Rudy Perez, Executive Director, Cedars-Sinai Facilities Planning, Design and Construction

The presentation reviewed the development process for the technology program at the Marina Del Rey Replacement Hospital, highlighting the integrated structure of workgroups involving enterprise leadership and subject matter experts. Key themes included the importance of guiding principles, research on emerging technologies, and the phased approach to implementing new systems. Rudy Perez emphasized the commitment to leveraging existing systems and ensuring consistent experiences across the health system.

# Technology and Research Committee

## Meeting Date: **Thursday, June 20, 2024**

### OVERVIEW OF TOPICS

- **Topic 2**

- Presentation: Healthcare Microgrids Update**

- Presenter:** Jamie Schnick, Senior Electrical Engineer, OSHPD

- Update on the efforts OSHPD has taken to develop the process for delivering Microgrids as Emergency Power Sources (EPS's) for California Healthcare Facilities

- This presentation was rescheduled due to illness.**



# Technology and Research Committee

## Meeting Date: **Thursday, June 20, 2024**

### OVERVIEW OF TOPICS

- **Topic 3**

- Technology and Research Committee Goals for 2024**

- Facilitator:** Gary Dunger, Committee Chair

- Discussion of Committee goals for the coming year

# Technology and Research Committee

## Current Goals:

- Explore subjects of telemedicine and robotics
- Discuss the effect of technologies on healthcare equity
- Explore emerging technologies that help reduce the carbon footprint for healthcare facilities and implementation relative to code implementation of emerging tools relative to the code.
- Address how to regulate remote services (e.g., medical records, web-based nurse call, off-site server farms, etc.)
  - Define what is a medical record
  - Monitor CDPH electronic health records redundancy issues in the event of power failure and watch for potential effects to code
  - Invite industry members to address/inform the committee on the reliability of cloud-based systems (fire alarm, energy monitoring, etc.)
- Explore wastewater solutions

# Technology and Research Committee

## Additional goals to consider:

- Artificial Intelligence
  - Impact on healthcare and the importance of data analytics.
  - Real-Time Locating Services (RTLS).
- Cybersecurity Reporting:
  - Are facilities required to report cyberattacks to regulatory bodies?
  - Including this in a white paper for better understanding and handling of such incidents, especially those involving protected health information.

# Technology and Research Committee

## Meeting Date: **Thursday, June 20, 2024**

### OVERVIEW OF MOTIONS

- There were no motions presented for action.

# Technology and Research Committee

## Meeting Date: **Thursday, June 20, 2024**

### CONCLUSION

- Questions and Answers
- I move to accept the June 20, 2024, meeting report

Item #11

Building Standards Unit (BSU) Update

- Update on BSU accomplishments year-to-date
- Discussion and public input

*Facilitator: Richard Tannahill, Architect, Deputy Division Chief, HCAI  
(or designee)*

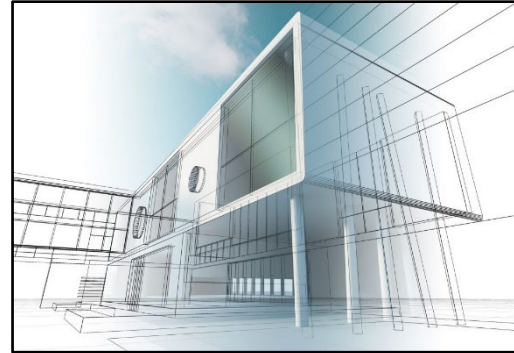

# Building Standards Unit Update

## August 15, 2024

# Building Standards Unit



**Marvelli, Mia@HCAI**  
Supervisor, Health Facilities Review  
HCAI



**Enright, Lawrence**  
Senior Mechanical Engineer



**Schnick, Jamie**  
Senior Electrical Engineer



**Campbell, Lori@HCAI**  
Staff Services Manager I



**Pamma, Simrit@HCAI**  
Staff Services Analyst (General)



**Wu, Clara@HCAI**  
Compliance Officer, Health Facil...



**Coleman, Paul@HCAI**  
Senior Architect



**Smith, Teresa@HCAI**  
Seasonal Clerk  
HCAI

## BSU Recruitment:

Senior Architect



# Building Standards Unit Role

## *Architectural, Mechanical and Electrical Technical Lead Support for all Regions*

- ✓ Plan Review Quality Assurance
- ✓ CPR/AMC Assistance
- ✓ Staff Training
- ✓ Liaison to CDPH
- ✓ Address Technical Questions from Design Professionals

## *Public Outreach and Support*

- ✓ Publish CANs/PINs/SoP's, Guides, etc.
- ✓ Conduct Webinars
- ✓ Monitor National Codes and Standards development
- ✓ Propose Title 24 Code changes
- ✓ Coordinate/Collaborate with State Agencies

✓ *Assist Executive Office with Legislative Analysis*

# *STATE AGENCY COORDINATION*

# State Agency Coordination

## California Department of Public Health

- ✓ Bi-weekly mtgs address outstanding items
- ✓ Title 22 Rewrite ongoing (assisting)
- ✓ Coordinate Title 24 code changes
- ✓ AB 2511 SNF REVIEWS
- ✓ Water Rationing Plans
- ✓ Methods of Procedures Guidance
- ✓ Processes for survey discovery of unauthorized projects
- ✓ Functional Program Rewrite
- ✓ Dietary Functional Program/Guide – Live
- ✓ COVID Reset coordination/Program Flex
- ✓ Indoor Air Quality Unit

## Mental Health Services Oversight and Accountability Commission

[SB 326 \(2023\)](#) Behavioral Health Services Act

Emergency Psychiatric Assessment, Treatment, and Healing ([EmPATH](#))

# Coordinate with CDPH

- ❑ Through bi-weekly meetings with CDPH leadership to resolve topics between HCAI and CDPH.
- ❑ Through monthly HCAI LA regions/CDPH District Offices (DO) meetings and ad-hoc meetings with CDPH DOs to address functional programs and AMCs related questions or concerns.
- ❑ We also coordinate with CDPH for the implementation of new requirements such as emergency water supply related to NPC-5 compliance and compliance with AB 2511 that requires SNF to provide additional alternative source of power.

# COVID Reset

## Suspension and Restoration of Temporary Conditions

- ✓ End of PHE was February 28, 2023
  - ✓ Non-compliant use of temporary spaces stops
- ✓ Restoration of physical environment: April 11, 2023
  - ✓ Restoration to original conditions must be reported to HCAI so that confirmation may be made.
- ✓ **Temporary changes are to be made permanent, projects must be submitted to HCAI for review and approval.**
- ✓ **Projects must meet current California Building Standards Code requirements and brought into full compliance.**
- ✓ **Non-compliant conditions cannot remain in use beyond February 28, 2023, without approval by CDPH per the Program Flexibility procedure above.**
- ✓ OSHPD is working with CDPH for Program Flex reviews

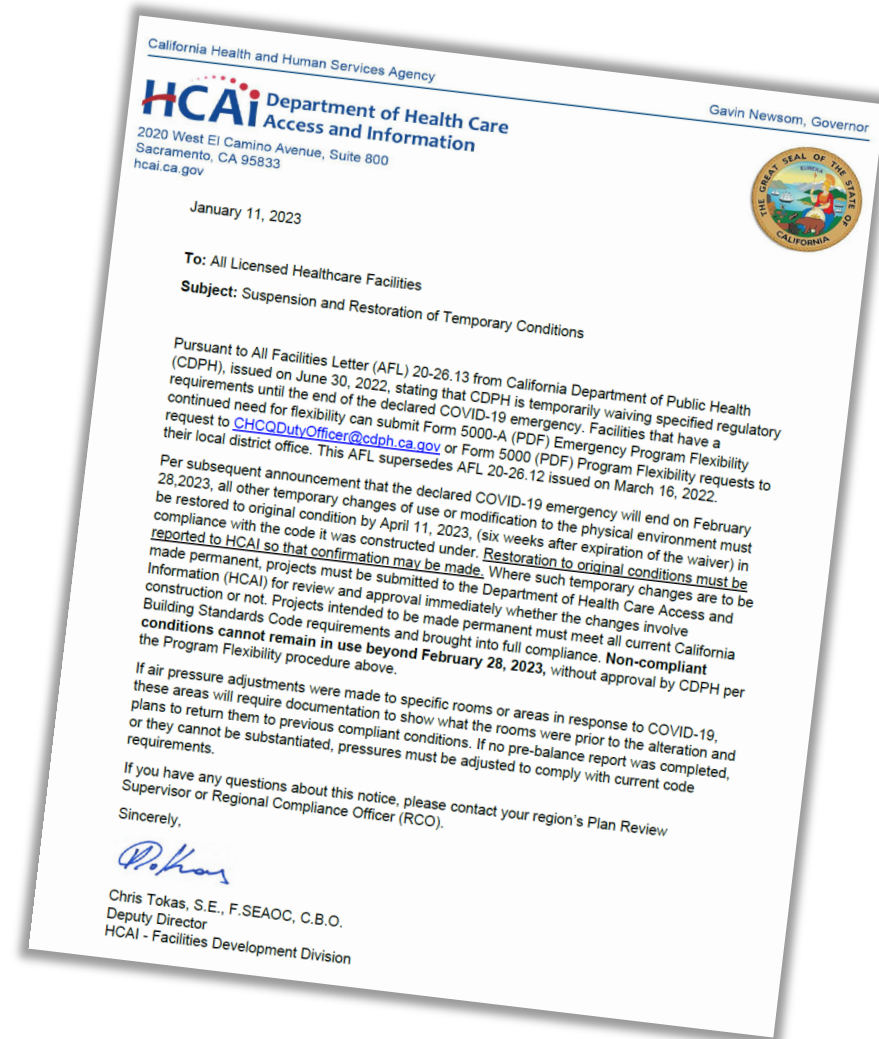

# *OUTREACH*

# AIA CV Academy of Architecture for Health

## ☐ AIA Central Valley Chapter – monthly meetings

2022 Intervening Code update

Remodel CAN

Recent Title 24 code changes

Alternate Method of Compliance process - RCO field staff

# National Codes and Standards Participation

- ❑ ASHRAE: SSPC 170, Ventilation of Health Care Facilities (Lawrence Enright)
- ❑ National Fire Protection Association
  - ❑ NFPA 70, National Electrical Code, Health Facilities backup power and microgrids
  - ❑ NFPA 99, Technical Committee Meeting: Electrical Systems – July 2024
- ❑ Federal Guidelines Institute: (Eric Jacobsen and Richard Tannahill)
  - ❑ Design and Construction of Hospitals, Imaging Class 1-3 and Treatment, Procedure and OR
- ❑ International Code Council, Committee on Healthcare



# Industry Conferences



HEALTHCARE  
FACILITIES  
symposium and expo



Request to Speak:

Health Care Microgrids can Lower Utility Costs, Meet Sustainability Goals and Increase the Resilience of your Facility

**Jamie Schnick**

Senior Electrical Engineer,  
HCAI

September 2024

# Industry

Request to Speak:

August & September 2024

City of San Diego Building Dept.

## OSHPD 3 ~ CLINICS

Richard Tannahill, Mia Marvelli,  
Jamie Schnick, Larry Enright

The City of **SAN DIEGO** CONNECT with the City

LEISURE Explore, Play, Events | RESIDENT RESOURCES Pay Now, Parking + Help | DOING BUSINESS Fix, Plan + Build | LIBRARY Learn, Connect + Discover | PUBLIC SAFETY Police, Fire + Lifeguards | CITY HALL City Officials + Departments

DSD Home | Permits, Approvals & Inspections | News & Programs | Zoning | Codes & Regulations | Forms & Publications | Public Hearings, Meetings & Notices | Fees | Records | Building & Land Use Enforcement

### Development Services

[Locations and Hours](#)

[Contact Us](#) [About Us](#)

[We're Hiring](#)

### Media Learning Center

Get access to educational video tutorials, webinars and podcast episodes

[CLICK HERE](#)

### Most Requested Services

- [Apply for a Permit Online](#)
- [Schedule an Appointment](#)
- [View Permit Application Processing Timeline](#)
- [Pay or Find an Invoice](#)
- [Schedule an Inspection](#)
- [View Building & Land Use Enforcement Cases](#)

# CANs/PINs/Guides/Webinars

## Published

- ❑ **CAN 1-0 Enforceable Codes**
  - ❑ Reissued to clarify that the California Administrative Code is effective 30 days after filing with the Secretary of State.
  
- ❑ **CAN 2-0 OSHPD Jurisdiction**
  - ❑ Revised to add Chemical Dependency Recovery Hospitals [OSHPD 6] to the introduction.
  
- ❑ **CAN 2-108 Temporary/Interim Structures, Tents and Equipment Uses**
  - ❑ Reissued to refer to the 2022 edition of Title 24 with the July 1, 2024 Supplement. Clarifies that only one extension will be granted for a building permit for temporary structures and temporary uses. Adds information from the California Administrative Code on who can prepare and submit construction documents and explains that temporary equipment may become interim equipment in specific circumstances. Adds a section on tents used for temporary purposes.

<https://hcai.ca.gov/facilities/building-safety/codes-and-regulations/#cans-pins-faqs>

# CANs/PINs/Guides/Webinars

## Published

- ❑ **CAN 3-517.30(B.1)(4) Health Care Microgrids as Type 1 Essential Electrical System (EES) Source**
  - ❑ Provides minimum standards required for the health care microgrid to be considered to have sufficient reliability. Also, provides direction on how to meet the on-site fuel storage requirements for health care microgrid sources other than diesel generators.
  
- ❑ **CAN 1-7-153(b) Non-Material Alterations (NMA)**
  - ❑ Revised to reflect 2022 Supplement changes to the California Administrative Code, Section 7-153(b)4. Clarifies how to handle full size sheets submitted as NMAs and adds information for NMAs not concurred within 4 weeks. Added repercussions for work performed without a concurred NMA.
  
- ❑ **CAN 2-1.10.6 OSHPD 6 Chemical Dependency Recovery Hospitals**
  - ❑ Issued to explain the new classification of supplemental service, OSHPD 6, which was added during the 2022 Intervening Code Cycle. Clarifies OSHPD's jurisdiction for Chemical Dependency Recovery Hospitals [OSHPD 6].

<https://hcai.ca.gov/facilities/building-safety/codes-and-regulations/#cans-pins-faqs>

# CANs/PINs/Guides/Webinars

## Published

- ❑ **PIN 74 Skilled Nursing Facility Alternate Source of Power**
  - ❑ Reissued to permit fuel delivery if 96 hours fuel is not available onsite. Edited Special Seismic Certification section to clarify California Building Code sections, and Alternative Source of Power section updated to provide clarity. Edited the Onsite Source of Power Assessment section to clarify that the assessment is required and HCAI will review the assessment for compliance with HSC §1418.22 before sending to CDPH.
  
- ❑ **PIN 76 Inspection Services Companies and Project Management: Ethical Practices and Incompatible Activities**
  - ❑ Issued to clarify what constitutes conflict of interest for Inspection Services Companies performing consulting services and Project Management on OSHPD projects.
  
- ❑ **PIN 61 Reasonable Accommodation for Hospital Inspector Certification and Recertification Examinations**
  - ❑ Revised to update address changes and contact information for the Department of Health Care Access and Information.

<https://hcai.ca.gov/facilities/building-safety/codes-and-regulations/#cans-pins-faqs>



# CANs/PINs/Guides/Webinars

## Published

- ❑ **Advisory Guide A5 - NPC-5 Water Rationing Plan for Hospital Facilities**
  - ❑ Addresses code requirements for the Nonstructural Performance Category 5 (NPC-5) water rationing plan to support 72 hours of emergency operations and frequently asked questions to HCAI OSHPD and CDPH. Adds a clarification for wastewater holding tanks and essential electrical power requirements for operating rooms.
  
- ❑ **Advisory Guide A6 – Alternate Source of Power to Maintain Safe Temperatures, Life-Saving Equipment, and Oxygen-Generating Devices**
  - ❑ Addresses frequently asked questions to OSHPD and CDPH as they relate to Skilled Nursing Facilities, OSHPD 2 Buildings, and Health and Safety code Section 1418.22 requirements.
  - ❑ Clarifies safe temperature ranges and Federal Code requirements, explains how safe temperatures can be researched and achieved, and includes Special Seismic Certification requirements.
  
- ❑ **Advisory Guide A9 – Sitework Under OSHPD Jurisdiction**
  - ❑ Addresses site jurisdiction carried forward from CAN 2-0  
<https://hcai.ca.gov/facilities/building-safety/resources/training-education/>

# CANs/PINs/Guides/Webinars

## Presented

- ❑ **Preapproved Fabricated Components and Systems Webinar**
  - ❑ June 25, 2024
  - ❑ 393 Attendees
  - ❑ Educated on the advantages of leveraging prefabrication, modular design theory, and design for manufacture and assembly.
  
- ❑ **2022 Title 24 Intervening Code Cycle – Part 1 and Part 2, Volume 1 Webinar**
  - ❑ June 26, 2024
  - ❑ 427 Attendees
  - ❑ Educated about the code changes that became effective July 1, 2024 in the 2022 California Building Standards Code, Title 24 of the California Code of Regulations, Intervening Code Supplement.

<https://hcai.ca.gov/facilities/building-safety/resources/building-safety-construction-webinars/>



# eCA Submission Ad page

- Announces all recently published E&O material
- Will be published soon on the Application for New Project and Post Approval Document submission page flow
- esp.oshpd.ca.gov

## Recent Releases of Revised PINs, CANs and Advisory Guides

### **PIN 61 - Reasonable Accommodation for Hospital Inspector Certification and Recertification Examinations**

Effective: 12/29/2014  
Revised: 08/01/2024  
[Link to PIN 61](#)

### **CAN 2-0 - OSHPD Jurisdiction**

Effective: 07/11/2024  
[Link to CAN 2-0](#)

### **CAN 2-1.10.6 - OSHPD 6 Chemical Dependency Recovery Hospitals**

Effective: 07/11/2024  
[Link to CAN 2-1-10-6](#)

### **Advisory Guide A5 - NPC-5 Water Rationing Plan for General Acute Care Hospital Facilities**

Revised: May 2024  
[Link to Advisory Guide A5](#)

### **PIN 74 - Skilled Nursing Facility (SNF) alternate source of power to maintain safe temperatures, maintain availability of life-saving equipment, and maintain oxygen-generating devices**

Revised: 05/31/2024  
[Link to CAN 2-0](#)

### **CAN 1-7-153(b) - Non-Material Alterations (NMA)**

**Effective: 06/08/2023**  
Revised: 07/15/2024  
[Link to CAN 1-7-153\(b\)](#)

### **CAN 2-108 - Temporary / Interim Structures, Tents and Equipment Uses**

Effective: 07/15/2013  
Revised: 06/03/2024  
[Link to CAN 2-108](#)

### **Advisory Guide A6 - Alternate Source of Power to Maintain Safe Temperatures, Life-Saving Equipment, and Oxygen-Generating Devices**

[Link to Advisory Guide 6](#)

View all PINs and CANs at

[Link to PINs and CANS](#)

If you have any questions, contact [RegsUnit@hcai.ca.gov](mailto:RegsUnit@hcai.ca.gov)

# CANs/PINs/Guides/Webinars

## Coming Soon

- ~~CAN 2-0 OSHPD Jurisdiction~~
- ~~CAN 2-1.10.6 OSHPD 6 Chemical Dependency Recovery Hospitals~~
- CAN 2-102.6 Remodel
- CAN 2-2508.2.1 Weather Protection for Gypsum Wallboard
- CAN 2-1224.4.4.4 Self-Contained Medication Dispensing Units
- PIN XX Structural Steel QA/QC Ready for Processing
- Medication Dispensing Units
- ~~Advisory Guide A3 - Dietetic Design and Review Checklist for Hospital and SNF Facilities~~
- ~~Advisory Guide A4 - Acute Psychiatric Hospitals~~
- ~~Electrical Guide for Health Facilities~~

*Title 24*  
*California Building*  
*Standards Code*  
*Update*

# Timeline

- ✓ **2022 edition Supplement (blue pages) goes into effect July 1, 2024**
- ✓ **2025 Edition of Title 24 (2024 Triennial Code Cycle)**
  - Aug. 2023, Submit Electrical to CBSC
  - Feb. 2024, Submit Mech and Plumb. to CBSC
  - May 2024, Submit Admin, Building Vol. 1 & 2, Existing to CBSC

# OSHPD Timeline and HBSB Meetings

## DUE TO CBSC

**Feb. 2024**  
**Submit CMC and CPC**

**May 2024**  
**Submit CAC, CBC, Vol. 1 & 2,**  
**and CEBC**

## REVIEWED BY HBSB/COMMITTEE

**Sept. 14, 2024 (Codes and Process) CEC**  
**Jan. 10, 2024 (Codes and Process) CMC and CPC**

**Feb. 21, 2024 (Codes and Process) CAC, CBC Vol. 1**

**Mar. 6, 2024 (Struct & Non-Struct) CAC, CBC Vol. 2 and CEBC**

**Apr. 18, 2024 HBSB Full Board meeting**

**May 8, (Codes and Process) FLS (SFM) related items**

# CBSC Code Advisory Committee dates

GREEN — MARCH 18-19, 2024	+
PEME — MARCH 25-26, 2024	+
ACCESS — JUNE 4-5, 2024	+
BFO — JULY 9-11, 2024	+
SDLF — JULY 16-17, 2024	+
HF — JULY 30, 2024	+

**Familiar faces:**  
Connie Christensen-HF Ex-Officio  
Gary Dunger-HF  
Belinda Young-HF  
Bill Zellmer-HF & ACCESS



# CBSC Public Comment Periods

## 45-Day Public Comment Period

PEME	May 17 – July 1
PEME 15-DAY	July 29 – August 13
SDLF/BFO/HF	September 6 – October 21

[Public Comments \(ca.gov\)](https://www.ca.gov)



# CBSC Commission Meetings

## Commission Meetings

December 14, 2023 - Code Advisory Committee Member Selection

January 18, 2024 - Closed Session Unrelated to Rulemaking

April 16, 2024 - Closed Session Unrelated to Rulemaking

July 18, 2024 - Cancelled

October, 17, 2024

December 17-19, 2024

January, 14-16, 2025

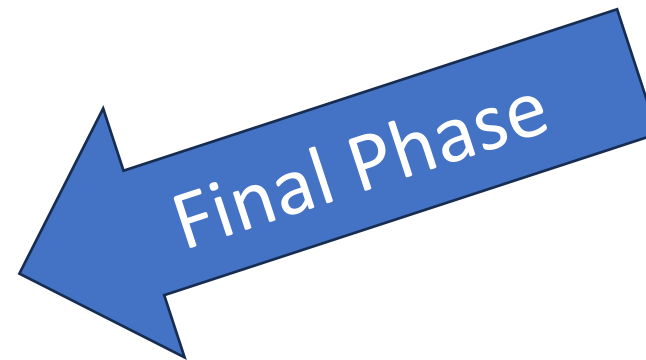

[Commission Meetings \(ca.gov\)](https://www.ca.gov)

## SUBSCRIBE TO CBSC'S MAILING LIST

Stay in touch with CBSC and receive meeting and public comment period notices, information bulletins, quarterly newsletters and more! Add your email address to our mailing list by visiting [DGS' govDelivery Subscription Service](#) webpage. After submitting your email, be sure to select the "CBSC Communications" topic on the next page. View our [Privacy Policy](#) for more information.

[www.dgs.ca.gov/BSC/Contact](http://www.dgs.ca.gov/BSC/Contact)

CBSC Rulemaking page [www.dgs.ca.gov/BSC/Rulemaking/2024-Triennial-Cycle](http://www.dgs.ca.gov/BSC/Rulemaking/2024-Triennial-Cycle)

- Any Questions?
- Any Additional Thoughts or Discussion?



LUNCH BREAK

Item #10

Office of Statewide Hospital Planning and Development (OSHDP)  
Update

- Workload and performance
- Personnel changes
- Discussion and public input

*Facilitator: Chris Tokas, SE, F.SEAOC, CBO, Deputy Director, HCAI  
(or designee)*



# **OSHPPD Briefing to the HBSB**

**Chris Tokas, S.E., C.B.O., F. SEAOC**  
Deputy Director, Office of Statewide Hospital Planning & Development

August 2024



# Excellence

# CBSC 2022 Intervening Code Adoption Schedule

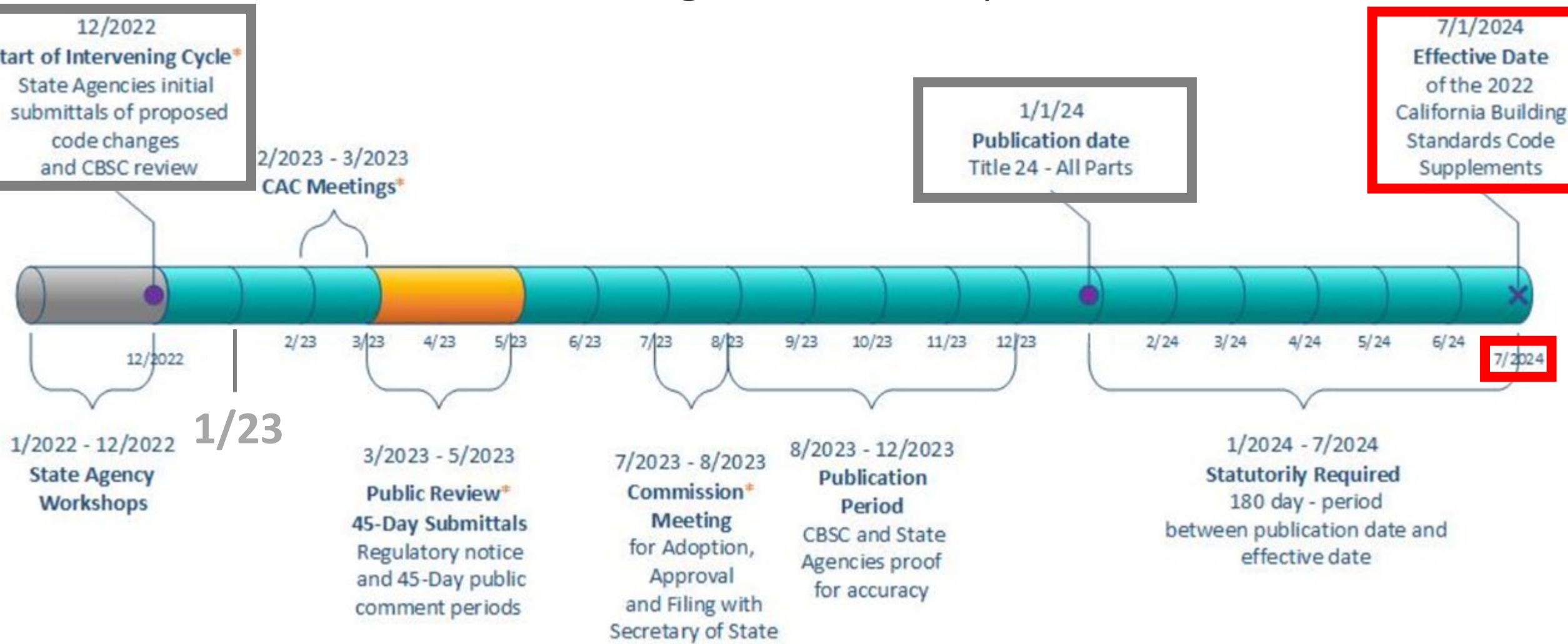



# Updates to the 2022 California Building Code (Intervening Code Changes)

## 2022 California Administrative Code, T-24, Part 1

- **7-129. Time limitations.**

- 7-129 (e) . . . . Once project completion Substantial Compliance or a Certificate of Occupancy is issued, final closeout documentation must be submitted within 90 days or the Substantial Compliance or Certificate of Occupancy will be revoked, ...

- **7-133. Fees.**

- (q) Amended construction documents (ACDs). . .
  - ACD for Cost reductions or No cost: Filing fee \$500.00 + actual costs for review and approval
- (r) Projects with no construction.
  - Filing fee of \$250.00 + actual costs for the review of project

# Updates to the 2022 California Building Code (Intervening Code Changes)

## 2022 California Administrative Code, T-24, Part 1

- **7-144. Inspection.**
  - (a) The hospital governing board or authority shall provide for competent, adequate and continuous inspection by one or more Inspector(s) of Record (IOR) . . .
  - (b) . . .
  - (c) . . .
  - (d) . . .
- **7-215. Conduct relative to performance. . .**

### *Advisory Notice to Health Facilities, IORs, & Approved Agencies*

**"1701A.3 Special inspections and tests. [OSHPD 1 and 4] In addition to the inspector(s) of record required by the California Administrative Code (CCR, Title 24, Part 1), Section 7-144, the owner shall employ one or more approved agencies to provide special inspections and tests during construction on the types of work listed under Chapters 17A, 18A, 19A, 20, 21A, 22A, 23 and 25, and noted in the Test, Inspection and Observation (TIO) program required by Sections 7-141, 7-145 and 7-149, of the California Administrative Code. Test, Inspection and Observation (TIO) program shall satisfy require . . .**

If you are currently using practices exempt from the remedies to . . .

California Health and Human Services Agency

Gravin Newsom, Governor

Sincerely,  
  
Chris Tokas,  
Deputy Director  
HCAI – Office of . . .

**HCAI** Department of Health Care  
Access and Information  
2020 West El Camino Avenue, Suite 800  
Sacramento, CA 95833  
hcai.ca.gov



January 16, 2024

All Health Facilities, Inspection Services Companies,  
Approved Agencies, and Inspectors of Record under HCAI  
Jurisdiction

RE: HCAI/OSHPD Inspection Services Unit (ISU) **Advisory Notice**

HCAI's Inspection Services Unit (ISU) is aware that Inspection Services Companies, IORs, and Approved Agencies continue to enter into contractual agreements that are not consistent with acceptable practices identified in the regulations to preserve the objectivity of these quality assurance entities. These ongoing and growing practices are in violation of the state's building regulations. **This advisory notice provides advanced warning that HCAI will take decisive action to correct this practice when it is discovered. Such action may result in a project delay, stop work order, revocation of the building permit, IOR certificate suspension / revocation, and/or cancellation of Approved Agency's Pre-Approved status in the HCAI OPAA Program.**

The CALIFORNIA BUILDING CODE (CBC) and CALIFORNIA ADMINISTRATIVE CODE (CAC), CALIFORNIA CODE OF REGULATIONS (CCR), TITLE 24 (T24) requires the health facility, owner, or governing board or authority employ approved agencies for special inspections and tests during construction and identified on the Test, Inspection and Observation (TIO) program. The regulations make no allowances for other entities to employ approved agencies or special inspectors for this work.

Consequently, HCAI will not permit any agreements that create a contract for approved agency services or special inspections by any entity not specified in 1701A.3. HCAI will strictly enforce 1701A.3 to ensure projects are not compromised due to a conflict of interest, impacting the objectivity and independence of the entities engaged in the testing and inspection for projects. Refer to code excerpt shown below.

CALIFORNIA BUILDING CODE (CBC)  
CHAPTER 17A  
SPECIAL INSPECTIONS AND TESTS

Page 1 of 2

# Updates to the 2022 California Building Code (Intervening Code Changes)

## 2022 California Building Code, T-24, Part 2, Volume 1

### 1224.33 EMERGENCY SERVICE . . .

#### 1224.33.2.7 Observation area . . .

- **1224.33.2.7.1 Behavioral health observation area.** If provided, a patient station with
  - Under the visual control of an emergency service staff work area
  - Visual privacy from casual observation by other patients and visitors
  - Min clear floor area of 40 square feet
  - Min of 3 feet at one side and any wall or any other fixed obstruction
  - Min clearance of 3 feet between beds, and 4 feet shall be available at the foot of each bed to permit the passage of equipment and beds.
  - A handwashing station shall be located in each room

...

# Updates to the 2022 California Building Code (Intervening Code Changes)

## 2022 California Building Code, T-24, Part 2, Volume 1

### • **AB 2096 (Mullin), CHAPTER 233, Stats 2022**

- Authorizes a chemical dependency recovery hospital (CDRH) to be located within a building that houses:
  - A distinct part acute psychiatric hospital,
  - An acute psychiatric hospital (APH), or
  - A general acute care hospital (GACH) where other services are provided,
- If :
  - The CDRH meets all other applicable building standards, and is separated by a wall, floor, or other permanent partition.
- CDRH does not need to be a “freestanding” building provided it shares an elevator, stairs, or stairwell with the facility in which it is located

# Updates to the 2022 California Building Code (Intervening Code Changes)

## 2022 California Building Code, T-24, Part 2, Volume 1

### • CHEMICAL DEPENDENCY RECOVERY HOSPITALS (OSHPD 6)

- **1229.1 Scope.** . . . GAC hospitals and APH hospitals licensed under Health & Safety Code Section 1250 may provide chemical dependency services as a supplemental service located within a distinct part as a separate unit. . . .

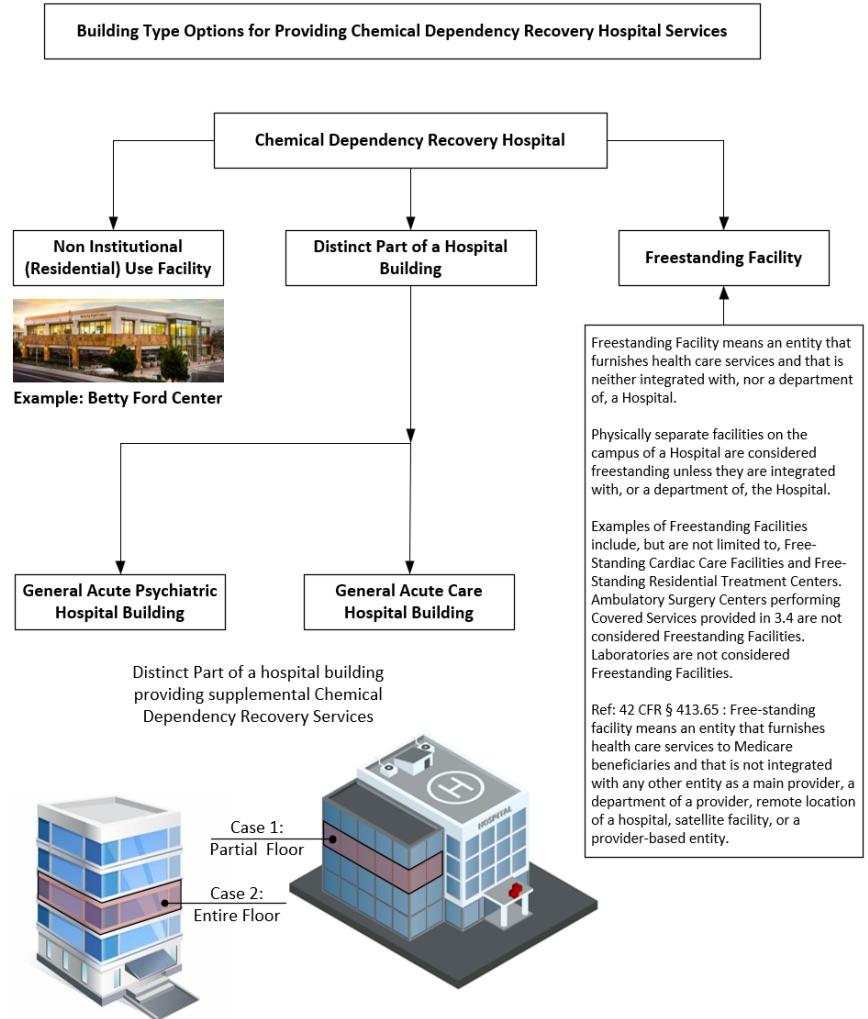

# Updates to the 2022 California Building Code (Intervening Code Changes)

## AB 2511 (Irwin), CHAPTER 788, Stats 2022

- SNFs requirements:
  - Alternative source of power, for no fewer than 96 hours during any type of power outage
  - Comply by January 1, 2024.
  - If noncompliant with the requirements of AB 2511 may be committing a crime or infraction. (Section 6 of Article XIII B of the California Constitution)

A skilled nursing facility shall have an **alternative source of power** to protect **resident health and safety** for no fewer than 96 hours during any type of power outage that may result from a public safety power shutoff, an emergency, a natural disaster, or other cause

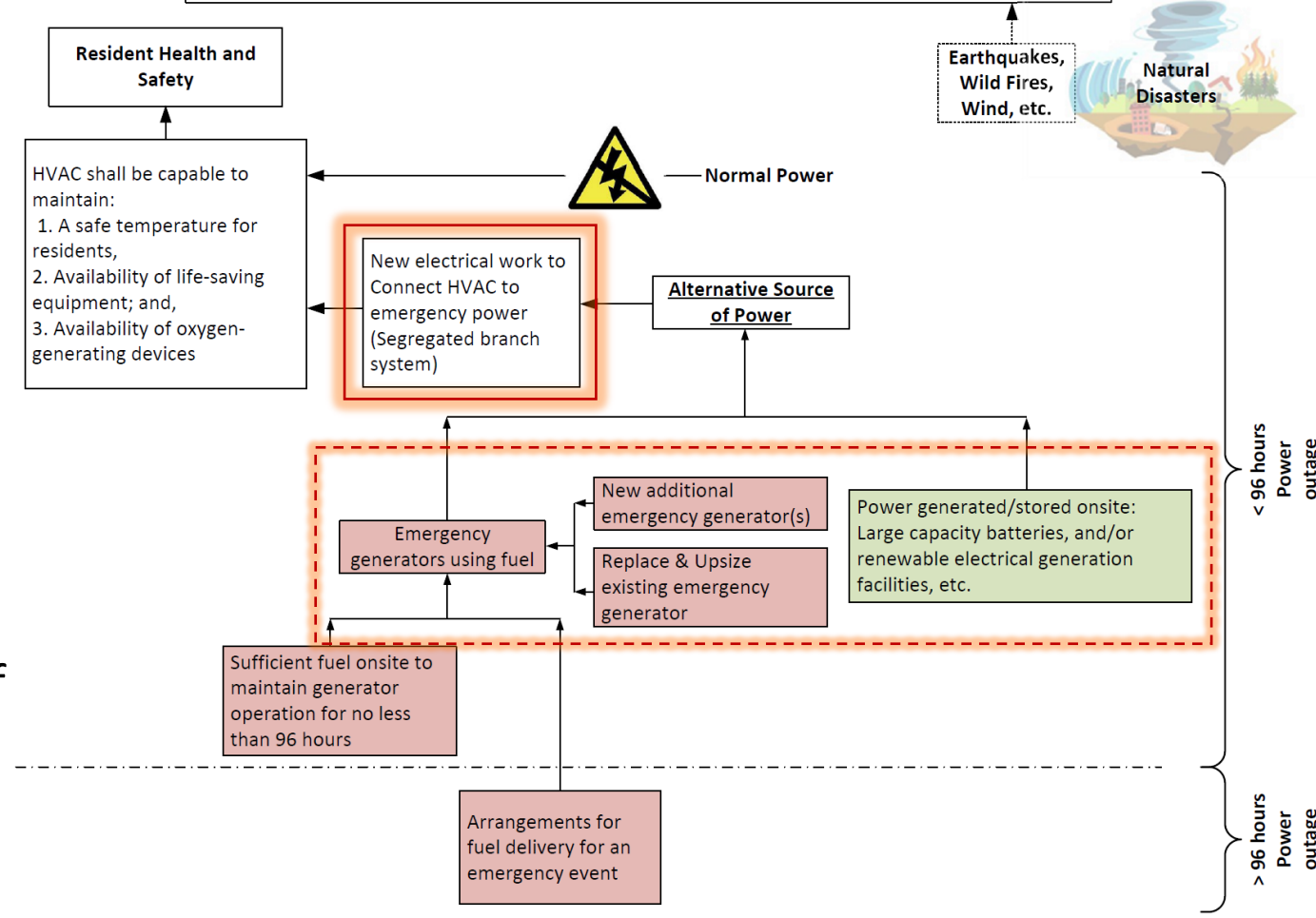

# Updates to the 2022 California Building Code (Intervening Code Changes)

## 2022 California Electrical Code, T-24, Part 3

### Alternate Power Requirements for SNFs

#### CEC Section 517.1 Scope

...

- **(B) OSHPD 2.** In addition to the essential power requirements included in this section, Skilled Nursing Facilities (SNFs) shall have an alternate source of power generated or stored onsite to supply power, during a power outage (caused by public safety power shutoff, an emergency, a natural disaster, or other cause) to feed:
  - Mechanical equipment required to maintain safe temperatures for residents.
  - Life-saving equipment.
  - Oxygen-generating devices.

...



# Updates to the 2022 California Building Code (Intervening Code Changes)

## 2022 California Electrical Code, T-24, Part 3

### Microgrids as Emergency Power Source for Hospitals and SNFs

#### CEC Section 517.30 Sources of Power

- **(B) Types of Power Sources**

...

- (4) Health Care Microgrid. EES shall be permitted to be supplied by a Health Care Microgrid that also supplies nonessential loads.
- Permitted to share distributed resources with the normal source.
- Designed with sufficient reliability to provide effective facility operation consistent with the facility emergency operations plan.
- Shall not be compromised by failure of the normal source.
- Meet the installation and commissioning requirements of NFPA 99 Article 6.10.



# AB 2511 – 96 Hours Emergency Power

## HCAI efforts for SNFs to Comply Successfully

- October/November 2022
  - HCAI Policy Intent Notice (PIN)
    - Endorsed by 3 HBSB Committees (Technology, Energy Conservation, and Codes and Processes, 11/1/2022)
    - Ready for Publication
- December 2022
  - HCAI publishes Policy Intent Notice
  - 12/1, HCAI submits proposed building standards/regulations to the CBSC (2022 Intervening building Code Cycle)
- January 1, 2023
  - eSP augmentations operational to accept project submittals
  - eSP augmentations to monitor implementation progress
  - AB 2511 requirements become enforceable
  - SNF projects submitted to HCAI
- March 2023
  - HCAI published **Advisory Guide (How-To)**
- January 1, 2024
  - Final deadline for SNFs to comply

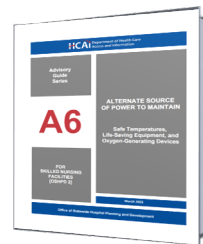

# AB 2511 – Facility Assessment Submittals/Status of compliance (8/12/2024)

	<u>Qty</u>	<u>Assessment State</u>
	299	No Assessment
856	1	Being Submitted
	1	Submitted – Returned to Client
	61	Submitted – Remarkd & Returned to Client
	1	Submitted – In Review
	2	Re-Submitted – In Review
	5	Submitted – Pending Determination
	756	HCAI Non-Compliant
	0	HCAI Compliant - Awaiting CDPH Concurrence
	29	HCAI Compliant – w/ CDPH Concurrence
	<hr/>	
	<b>1155</b>	

**855 submitted, 29 determined to be compliant**

# Process for SNFs to Comply w/ the Alternative Source of Power Requirements of AB 2511 to Protect Resident Health and Safety for no Fewer than 96 Hours During any Type of Power Outage

- Facility Systems Required to Comply w/ AB 2511**
- Heating System
  - Cooling System
  - Life-Safety Equipment (Ventilators, AED, Crash Carts)
  - Oxygen-Generation Devices (Concentrators, Positive Pressure Apparatus, and large-scale oxygen generation)
  - Emergency Generator(s)
  - Alternate Power Source(s) (Other than generator)

**OPTION 1 - Assess Existing SNF Physical Plant for Compliance**

- Required Facility Assessment Documents Substantiating Compliance**
- HSC §1418.22 Facility Assessment Worksheet(s)
  - Floor plan showing location of all systems and area of coverage.
  - Documentation substantiating compliance for each system listed above with HSC §1418.22 .
  - Electrical single line diagram.
  - Local approvals as required

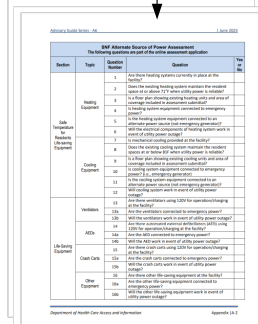

**OPTION 2**

- Plans
- Specifications
- Engineering Calculations
- Construction Cost Estimates

**Progress To Date**

Qty	Assessment State
299	No Assessment
1	Being Submitted
1	Submitted – Returned to Client
61	Submitted – Remarkd & Returned to Client
1	Submitted – In Review
	Re-Submitted – In Review
	Submitted – Pending Determination
75	HCAI Non-Compliant
0	HCAI Compliant - Awaiting CDPH Concurrence
29	HCAI Compliant – w/ CDPH Concurrence
<b>1158</b>	

855 submitted, 29 determined to be compliant

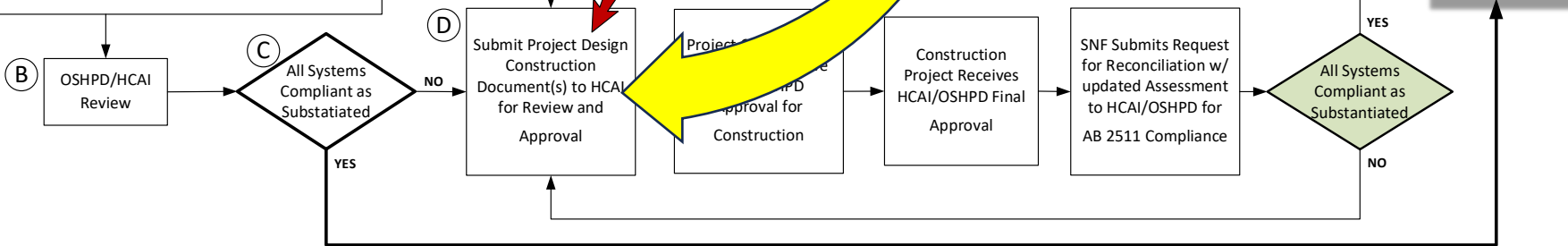

# 2024 CBSC Triennial Timeline (2025 T-24)



California Building Standards Commission

2025 California Building Standards Code, Title 24  
Effective January 1, 2026

## 2024 Triennial Code Adoption Cycle

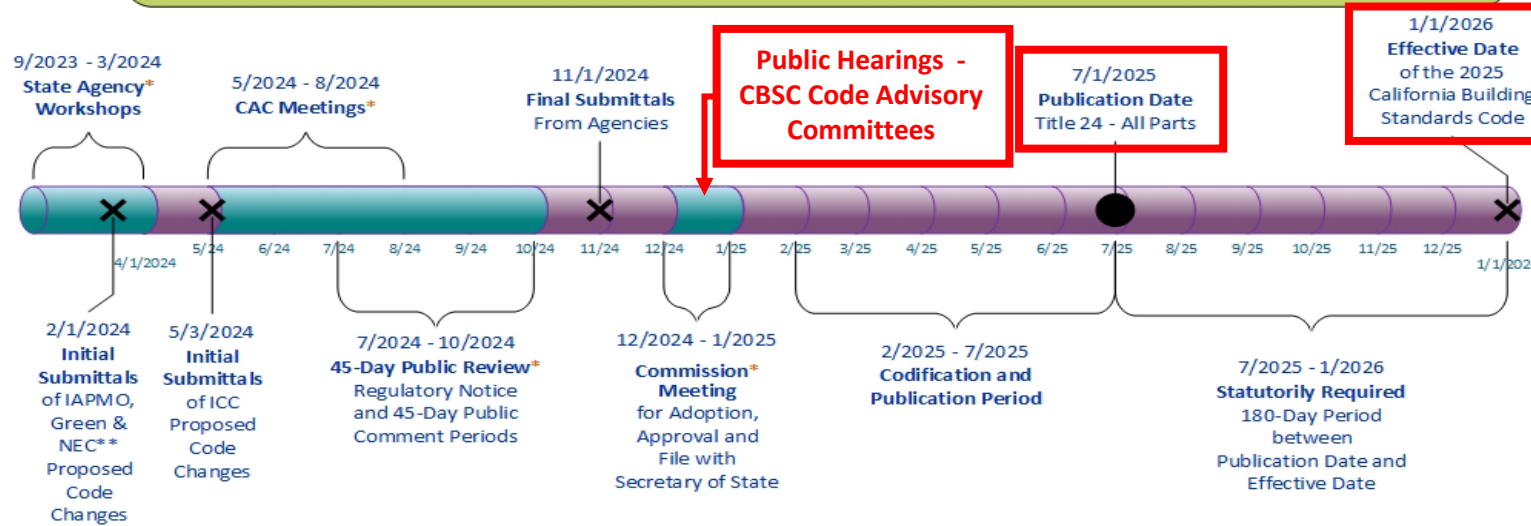

**Code Advisory Committees (CAC):**  
 ACCESS – Accessibility  
 BFO – Building, Fire & Other  
 GREEN – Green Building  
 HF – Health Facilities  
 PEME – Plumbing, Electrical, Mechanical & Energy  
 SDLF – Structural Design/Lateral Forces

**Model Code Publishers:**  
 ICC – International Code Council  
 IAPMO – International Association of Plumbing and Mechanical Officials  
 NFPA – National Fire Protection Association  
 \*\* NEC resubmittal if necessary

\* Public Participation Opportunity

[dgs.ca.gov/BSC](https://dgs.ca.gov/BSC)  
(916) 263-0916

Rev. 02/2022  
All dates are subject to change

# 2025 California Plumbing Code

## 2025 California Plumbing Code, T-24, Part 5

### Emergency Water Supply

*616.0[OSHPD 1] Emergency Water Supply.*

*616.1 For new acute care hospital buildings submitted...*

*616.3 Storage tanks connections and circulation shall be designed to limit water stagnation and temperature stratification. Supplemental disinfection and circulation shall be provided where the disinfection levels of the public water supply are not adequate to maintain minimum levels of disinfectant for water quality consistent with the facility's water management program.*

# 2025 California Electrical Code

## 2025 California Electrical Code, T-24, Part 3

### Electric Service Permitted to be Other Than the Utility Service

#### 517.4 [OSHPD 1, 1R, 2, 4 & 5] Electric Power Sources, Feeders and Services /Systems and Utilities.

- *One source (or sets of sources) shall be sized to supply power to support the entire healthcare facility electrical load*
- *The source(s) shall be one of the following:*
  - a. An off-site public utility source with service to the site*
  - b. On-site resources (PV's Batteries, fuel cells, etc.)*
  - c. A combination of both*
- *All sources (other than utility owned equipment) shall have Special Seismic Certification, **and be** located to minimize interruptions caused by natural forces or natural disasters identified in the facilities emergency operations plan.*

# CDPH and OSHPD joint issues, task force groups, etc.

- **CDPH Program Flexures (Flex)**

- OSHPD consultations to CDPH's Program Flex Unit (PFU)
- Occurrence:  $\pm$  6/Week
- OSHPD & PFU Joint monthly meetings
  - Typ. evaluate use of existing space temporarily for other services and may need some adjustment of the physical plant to accommodate that temporary use.
  - Occasionally, more complex assessment and may lead to providing guidance to the facility itself.

- **Purpose:** Provide valuable service!

- Utilizing specialized attributes only available when collaborating with both offices.

CDPH and OSHPD joint issues, task force groups, etc.

- **Hospital Water Conservation/Water Rationing Plans**

- Required for NPC-5 1/1/2030 compliance

- 306 Water Rationing Plan submittals currently



# CDPH and OSHPD joint issues, task force groups, etc.

- **Imaging Room Classification**

- Imaging modalities & use in therapeutic procedures evolving very quickly
- In 2018 FGI introduced a classification system
- Adopted in 2022 the CBC

- Determination of procedures for ea. *Class of Imaging Room* is very clinical

- Difficult to address in construction standards



# Class 1 Imaging Room – Diagnostic/Exam

Room	Proposed Use Definition	Room Type	Location	Finishes
<b>Class 1 Imaging Room</b>	<p><b>Diagnostic radiology</b>, fluoroscopy, mammography, computed tomography (CT), ultrasound, magnetic resonance imaging (MRI) &amp; other imaging modalities.</p> <p>Services that either <b>a) use natural orifice entry</b> and do not penetrate natural protective membranes or <b>b) are low-risk needle-based procedures</b> that do not require a sterile field</p>	<b>Unrestricted Area</b>	Accessed from an unrestricted area	<p><b>Flooring:</b> smooth, waterproof and durable, slip resistant in wet areas</p> <p><b>Walls:</b> washable</p> <p><b>Ceiling:</b> cleanable with routine housekeeping equipment; acoustic and lay-in ceiling permitted; no ledges or crevices</p>





# FGI Class 3 Imaging Room – Hybrid OR

Room	Proposed Use Definition	Room Type	Location	Finishes
<b>Class 3 Imaging Room</b>	<b>Invasive procedures;</b> Any Class 2 procedure during which the patient will require physiological monitoring and is anticipated to require active life support	<b>Restricted Area</b>	Accessed from a semi-restricted area	<b>Flooring:</b> homogenous, nonabsorbent, not affected by germicidal cleaning <b>Floor/wall base:</b> monolithic floor w/ integral coved base carried up the wall a minimum of 6" <b>Walls:</b> washable; free of fissures, open joints, or crevices <b>Ceiling:</b> monolithic, scrubbable, capable of withstanding cleaning and/or disinfecting chemicals, gasketed access openings



# Class 2 Imaging Room – The Gray Area Between

## Class 1 Imaging

(Exam/Treatment Room)

### Unrestricted Area

Accessed from an unrestricted area

An imaging room designated for the performance of patient care activities that **may require** high-level disinfected or sterile instruments but **does not require the environmental controls of a Class 2 imaging room** / procedure room.

## Class 2 Imaging

(Procedure Room)

### Semi-restricted Area

Accessed from an unrestricted area or a semi-restricted area

An imaging room designated for the performance of patient care activities that may require high-level disinfected or sterile instruments and **some environmental controls but do not require the environmental controls of a Class 3 Imaging Room.**

## Class 3 Imaging

(Hybrid Operating Room)

### Restricted Area

Accessed from a semi-restricted area

and has equipment to enable diagnostic imaging before, during and after surgical procedures.



# FGI Class 2 Imaging Room – Procedure Room

Room	Proposed Use Definition	Room Type	Location	Finishes
Class 2 Imaging Room	Diagnostic and therapeutic procedures such as coronary, neurological, or peripheral angiography; <u>Electrophysiology procedures</u>	Semi-restricted Area	Accessed from an unrestricted area or a semi-restricted area	<p><b>Flooring:</b> smooth, waterproof, durable, slip-resistant, able to withstand cleaning</p> <p><b>Floor/wall base:</b> monolithic floor w/ integral coved base carried up the wall a minimum of 6"</p> <p><b>Walls:</b> washable: free of fissures, open joints, or crevices</p> <p><b>Ceiling:</b> non-absorptive, non-perforated; capable of withstanding cleaning chemicals, lay-in ceiling permitted if gasketed or each ceiling tile weighs at least one pound per square foot and no perforated, tegular, serrated, or highly textured tiles.</p>



CDPH and OSHPD joint issues, task force groups, etc.

- **Imaging Room Classification**

- Determination of procedures for ea. *Class of Imaging Room* is very clinical
  - Difficult to address in construction standards
  - FGI to quantify procedure room/imaging room classification
  - OSHPD/CDPH working sessions to finalize White Paper

CDPH and OSHPD joint issues, task force groups, etc.

- **Operating Room Temperature Control Requirements**

- CBC/CMC requirements emanate from CDPH/CMS policies & min. requirements
  - CMS: ASHRAE Standard 170 for Ventilation of Health Care Facilities as a Condition of Participation.
- CMC Table 4A Reflects the ASHRAE 170 requirements.
  - Design temperatures for various spaces, including Operating Rooms, set at a range from 68 – 75 degrees.
    - Permitted to be lowered in response to surgical procedures
  - CDPH in discussion with OSHPD regarding status of the ORs after the event of an Earthquake.
    - **The Issue:**
      - Ventilation is required to continue to be supplied to each OR,
      - Cooling not included in the “essential mechanical provisions”.
    - **The question:** Is cooling for ORs essential for continued operation after a seismic event? All ORs, some? . . .

# Medicare and Medicaid Programs; Fire Safety Requirements for Health Care Facilities

- *“Health care facilities located in buildings that are taller than 75 feet are required to install automatic sprinkler systems within 12 years after the rule’s effective date.”*
  - NFPA 1 and 101 requires high rise hospitals to be fully sprinklered within 12 years of the adoption of NFPA 1.
  - CMS adopted the subject rule in 2016
  - Final compliance date July 5, 2028
- 42 CFR Parts 403, 416, 418, 460, 482, 483, and 485[CMS-3277-F]





# Seismic Compliance (SPC)

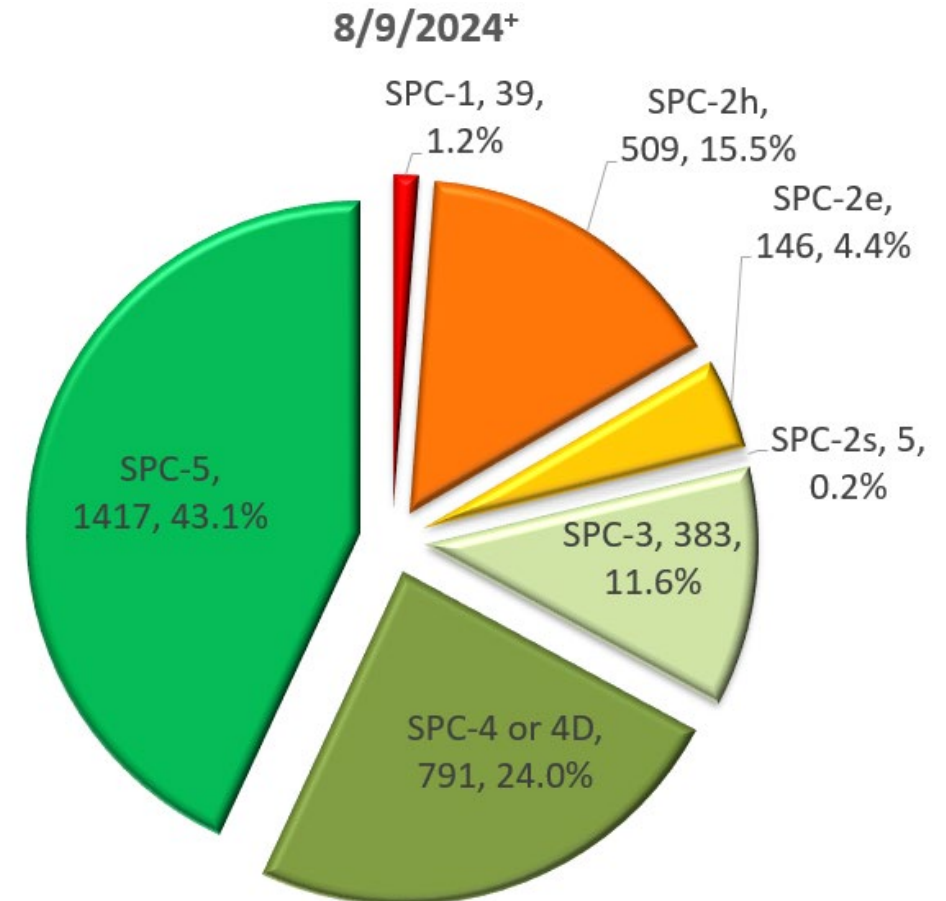
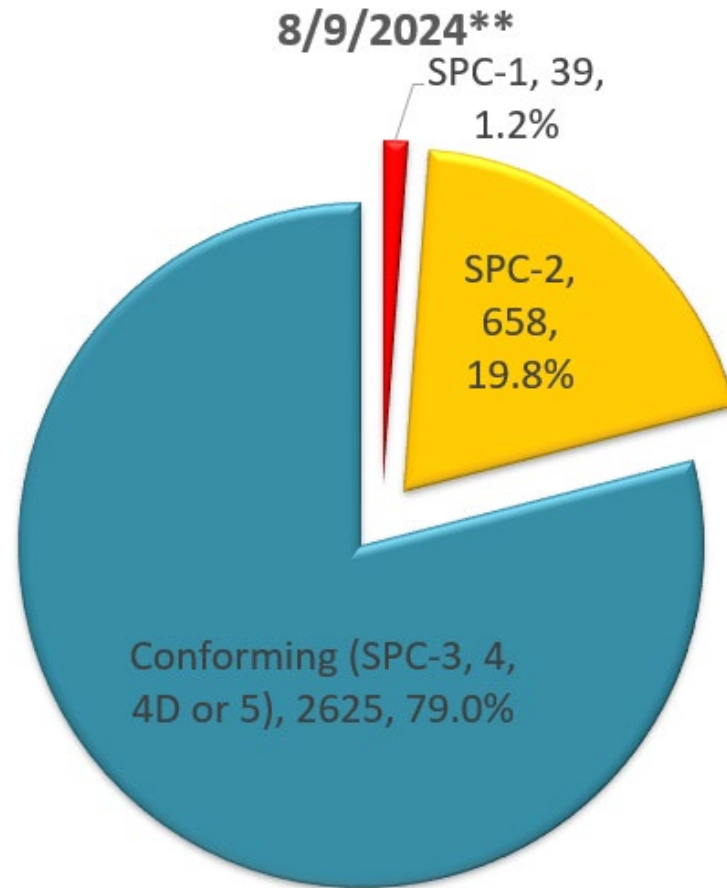

# Seismic Compliance (NPC)

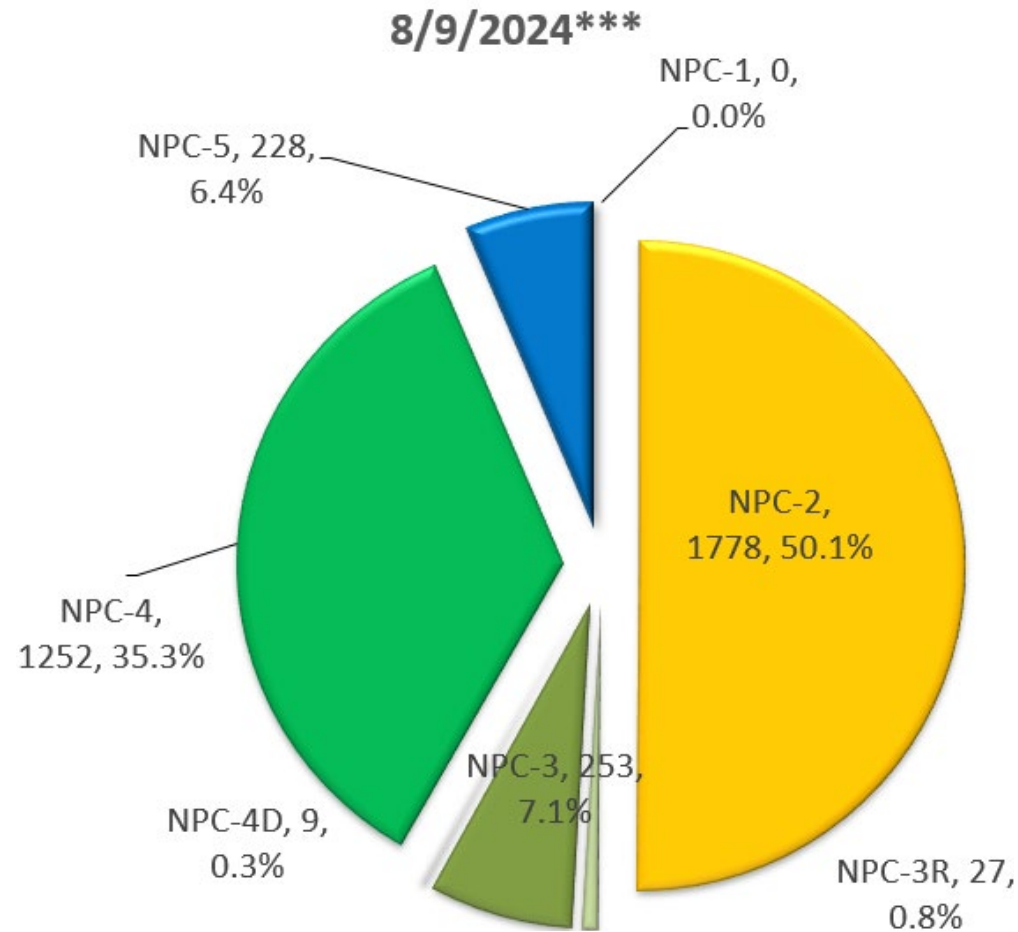

# January 1, 2024 - Seismic Compliance Required Submittals

## NPC Submittals (Required by California Administrative Code Chapter 6)

- NPC 3 compliance construction final document *[If GAC building is NPC 2 and located in extremely high seismic site – Seismic Design Category F]*
- NPC 4D Evaluation report including Operational Plan or NPC 4 Evaluation report
- NPC 5 Evaluation report including 72hr fuel evaluation and Water Rationing Plan
- Letter of Intent stating GAC services in the building will be removed by 1/1/2030 *[For GAC buildings planned to be removed from GAC services by 1/1/2030]*

## AB 1882 Submittals

- Licensed GAC Services Reporting Application *[[All buildings under HCAI jurisdiction ]*
- Signage Application *[All GAC Buildings]*

# August 15, 2024 - Seismic Compliance Required Submittals

## Non-Structural Performance (NPC) evaluations

- 3255\* Hospital Buildings required to submit evaluations

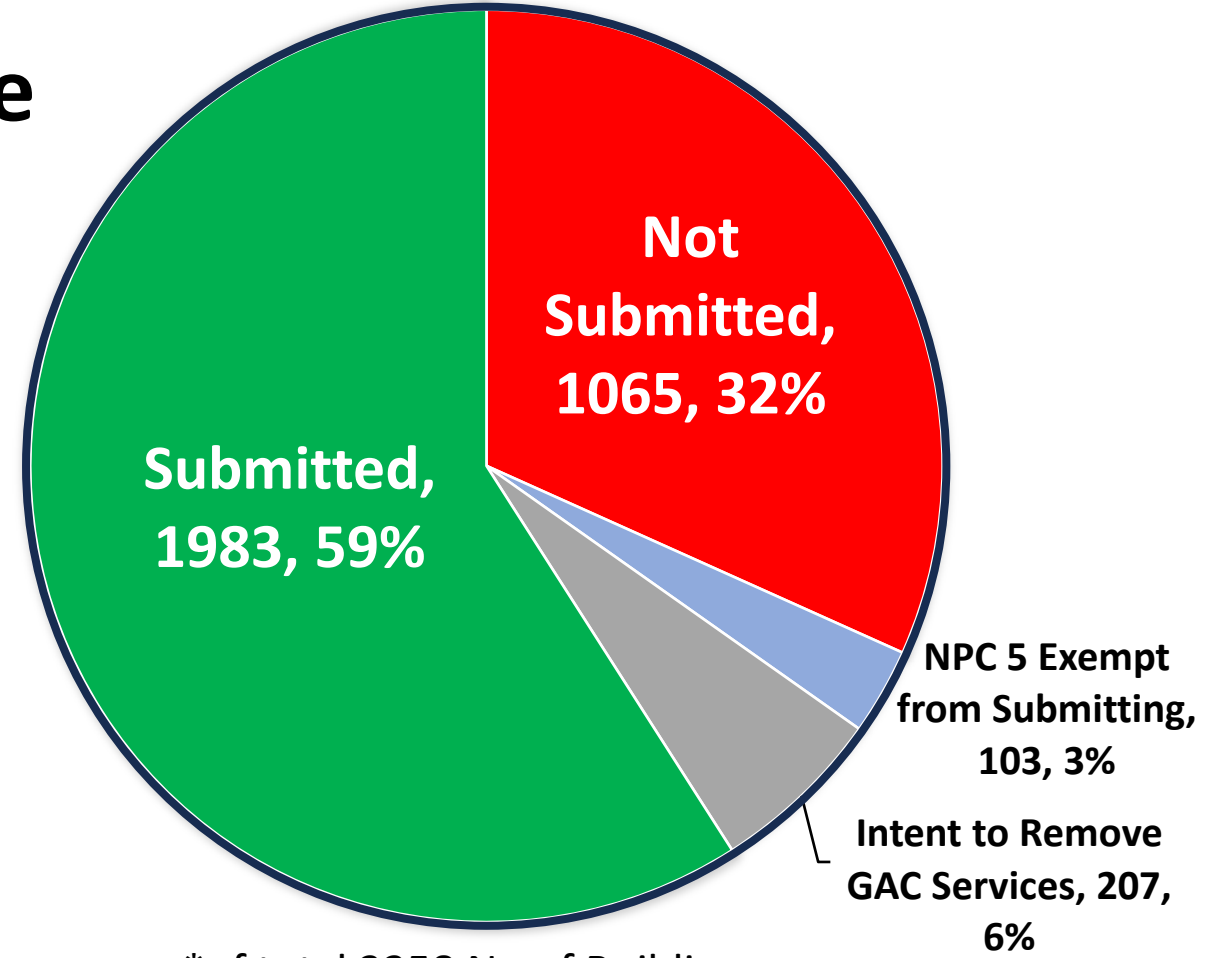

\*of total 3358 No of Buildings

# NPC Reporting Compliance Status – HCAI Web Page

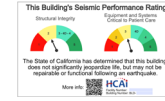

NPC Status

Seismic Performance Rating Signage

Bldg Num	Bldg Name	Classification & Status	RACs Date	NPC Status	Building Code	Year Built	Stories	Height in Feet	Instrumented	Construction Type	Sprinklered	AB1882 Signage	
<a href="#">BLD-01918</a>	Original Hospital Building / Additions	OSHPD 1, In Service	1/1/2030	1/1/2030 * NPC 4/4D Rpt: Submitted 12/26/2023 NPC 5 Rpt: Submitted 12/30/2023	1943 Uniform Building Code (UBC)	1947	1	15	No			Pending	SPC: 2 NPC: 2 This building does not significantly jeopardize life, but may not be repairable or functional following an earthquake
<a href="#">BLD-01919</a>	Building Block No. 2	OSHPD 1, In Service	1/1/2030	1/1/2030 * NPC 4/4D Rpt: Submitted 12/26/2023 NPC 5 Rpt: Submitted 12/30/2023	1946 Uniform Building Code (UBC)	1947	1	15	No			Pending	SPC: 2 NPC: 2 This building does not significantly jeopardize life, but may not be repairable or functional following an earthquake
<a href="#">BLD-01920</a>	1976 Alterations & Additions	OSHPD 1, In Service		1/1/2030 * NPC 4/4D Rpt: Submitted 12/26/2023 NPC 5 Rpt: Submitted 12/30/2023	1973 California Building Code (CBC)	1979	2	Unknown	No			Compliant	SPC: 4 NPC: 2
<a href="#">BLD-01921</a>	Two Story Addition West	OSHPD 1, In Service		1/1/2030 * NPC 4/4D Rpt: Submitted 12/26/2023 NPC 5 Rpt: Submitted 12/30/2023	1985 California Building Code (CBC)	1996	2	Unknown	No			Pending	SPC: 4 NPC: 2

# Notice of Non-Compliance w/ the Seismic Safety Requirements\*

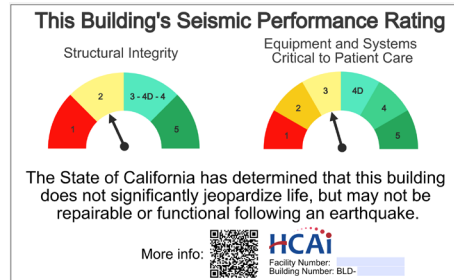

- 2632 Hospital ***Buildings*** required to be posted noticing the patients or the public

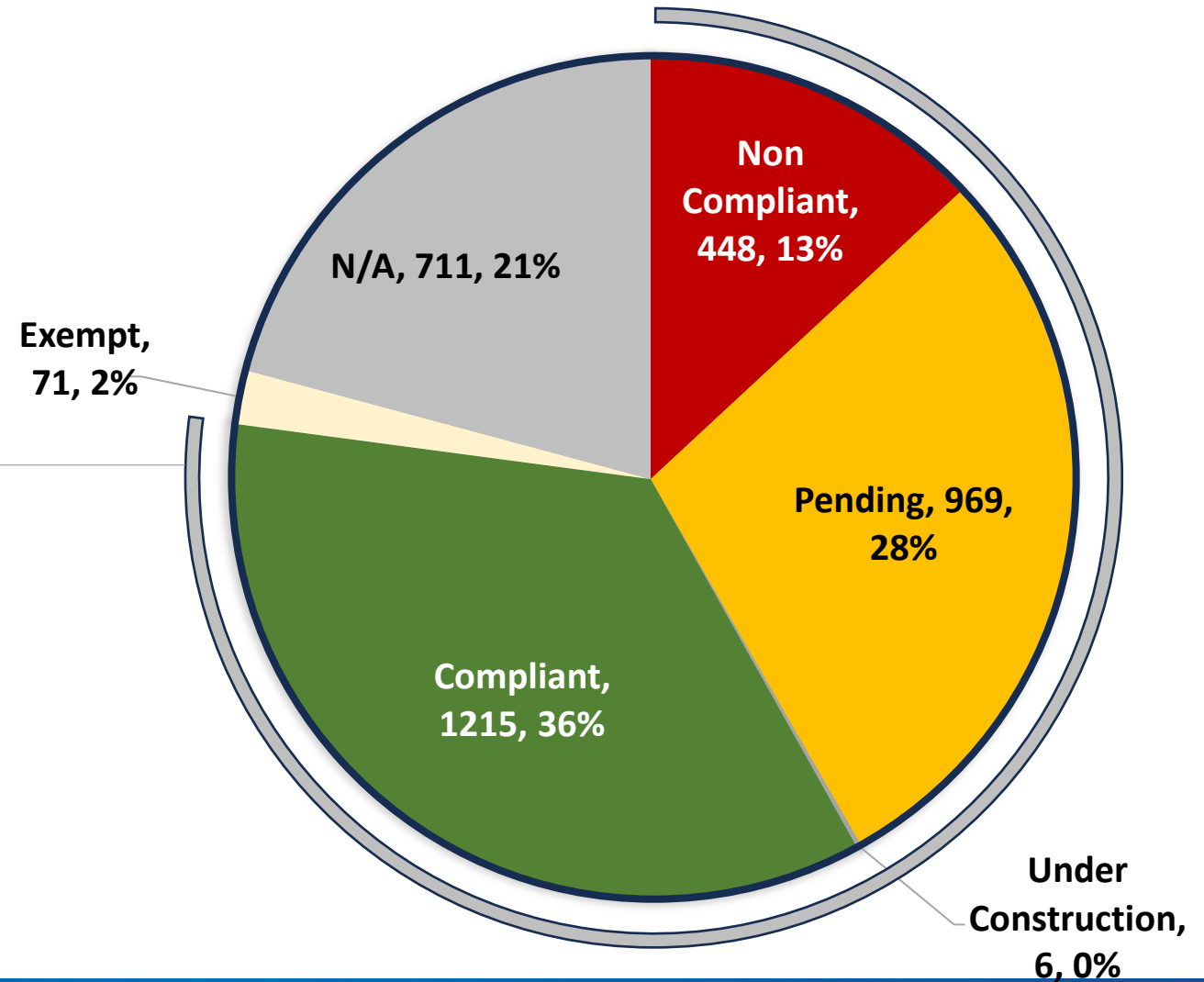

\*AB 1882, Chapter 584, Stats, 2022



# Electronic Services Portal - Automated Compliance Program

2030 Building Matrix

Bldg Num	Bldg Name	SPC	NPC	Code	Permit	Bldg Type	Stories
BLD-00513	Main Hospital Building	4D	4D, 5	1961 UBC	UNKNOWN	01 - Wood, Light Frame	1
BLD-00514	Mechanical Building	4D	4D, 5	1961 UBC	UNKNOWN	01 - Wood, Light Frame	1
BLD-00515	Rec. Room & Office Addition	4D	4D, 5	1967 UBC	UNKNOWN	01 - Wood, Light Frame	1
BLD-05681	Generator Shed	4D	4D, 5	1961 UBC	UNKNOWN	23 - Inverted pendulum - Steel Moment Resisting Frame	1
BLD-00516	Lab & Storage Addition	4	4D, 5	1979 UBC	H1151	01 - Wood, Light Frame	1
BLD-00517	Canopy Addition	4	4, 5	1979 UBC	SS880101	08 - Concrete Moment Resisting Frame	1
BLD-00518	Birth Center	5	4, 5	1995 CBC	HS971863	04 - Steel Braced Frame	1
BLD-02949	LDR Addition	5	4, 5	2007 CBC	HS071499	03 - Steel Moment Resisting Frame	1
BLD-05522	ER / Radiology / Clinic Addition	5	4, 5	2001 CBC	HS031721	03 - Steel Moment Resisting Frame	1
BLD-06036	Lobby Remodel & Addition	5	4, 5	2001 CBC	HS031721	03 - Steel Moment Resisting Frame	1
BLD-06037	Corridor Addition	5	4, 5	2001 CBC	HS031721	03 - Steel Moment Resisting Frame	1
BLD-06038	Mechanical & Electrical Building Addition	5	4, 5	2001 CBC	HS031721	14 - Reinforced Masonry Bearing Walls-Concrete Diaphragm	1
BLD-06039	Main Entrance Canopy Addition	5	4, 5	2001 CBC	HS031721	03 - Steel Moment Resisting Frame	1
BLD-06040	ER Canopy Addition	5	4, 5	2001 CBC	HS031721	03 - Steel Moment Resisting Frame	1

Table 2: 2030 Building Construction Matrix

## Compliance Plan Schedule

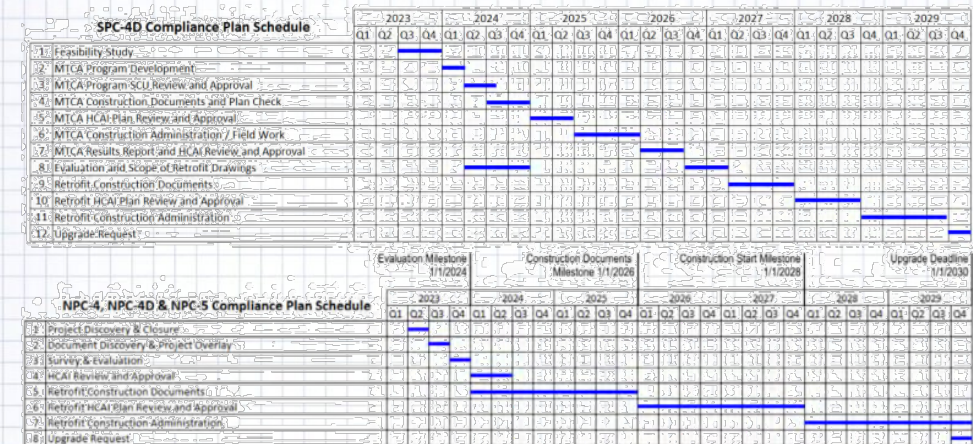
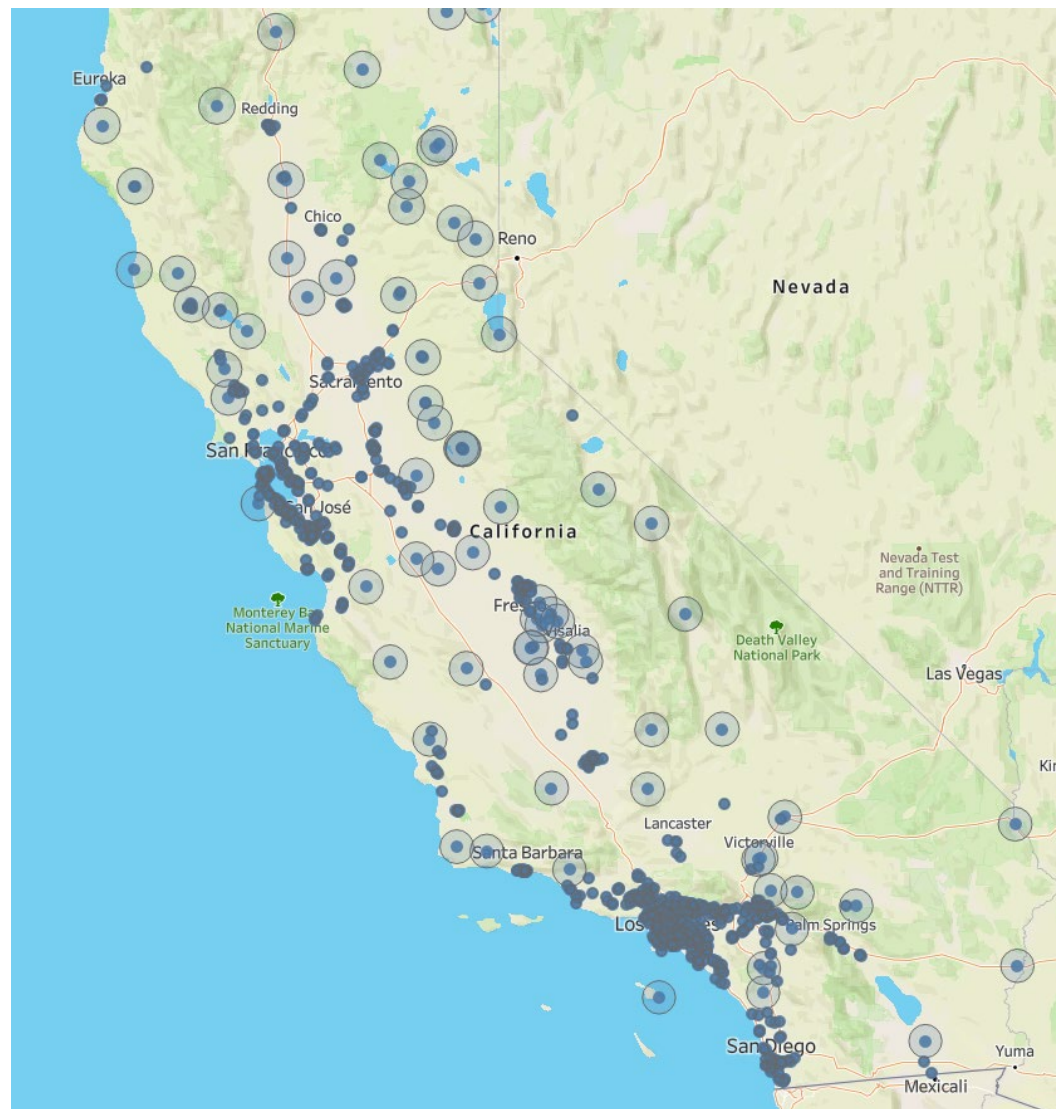

Table 3: SPC and NPC Compliance Schedules

Note: Time estimates are based on previous experience and may not be an accurate reflection of QSHPD review time, which is outside of the design team's control.



# Small and Rural Hospital Relief Program



- \$1,085K awarded to date:
  - \$280K Mee Memorial Hospital
  - \$180K Kern Valley District
  - \$625K approved – Mad River NPC-3
  - In review: Oak Valley and Plumas districts
- **\$7.2M +\$50M** transferred into Fund 3391 total to date
- 38 Applications Received
- 26 Eligibility Approved, 12 Pending Finalization, one not eligible

# Workload in Construction Costs for Projects Over Time



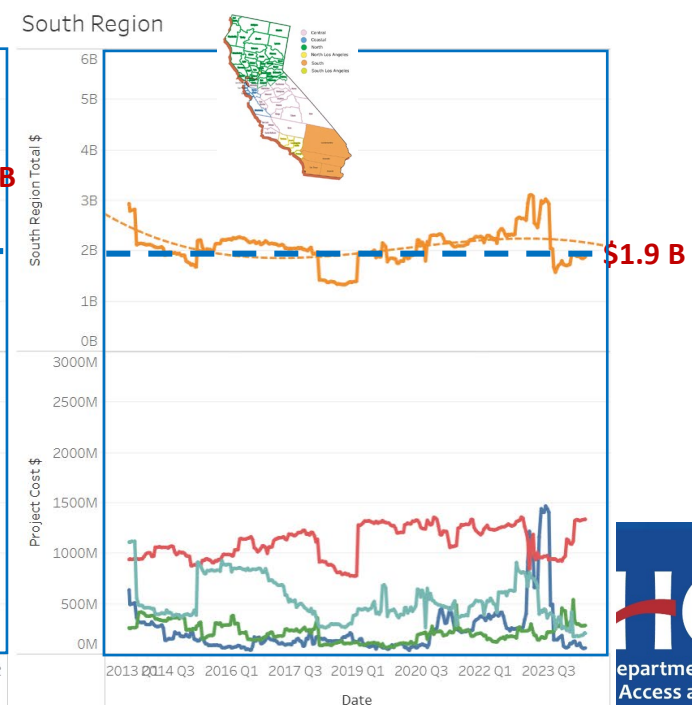
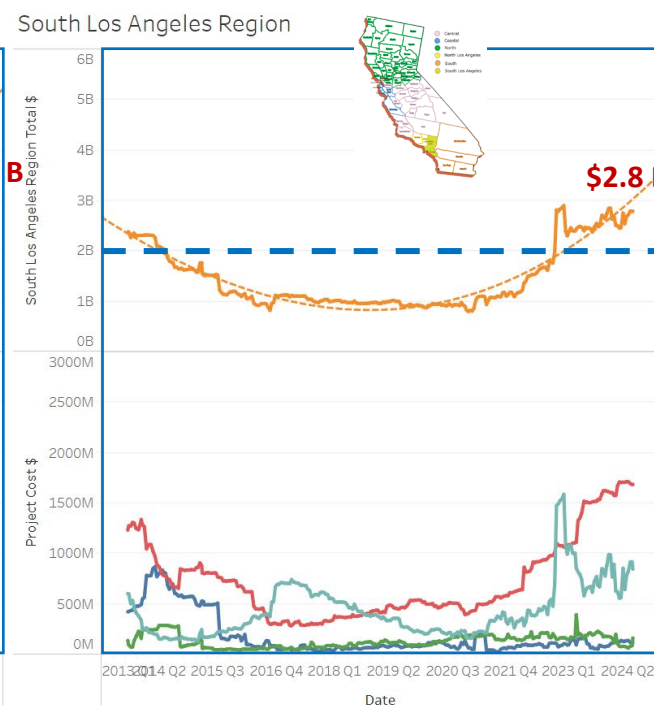
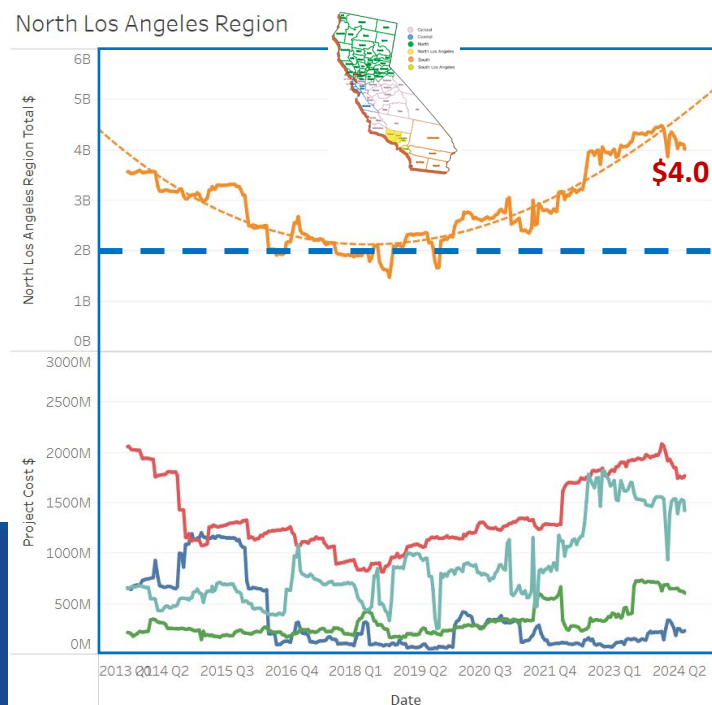
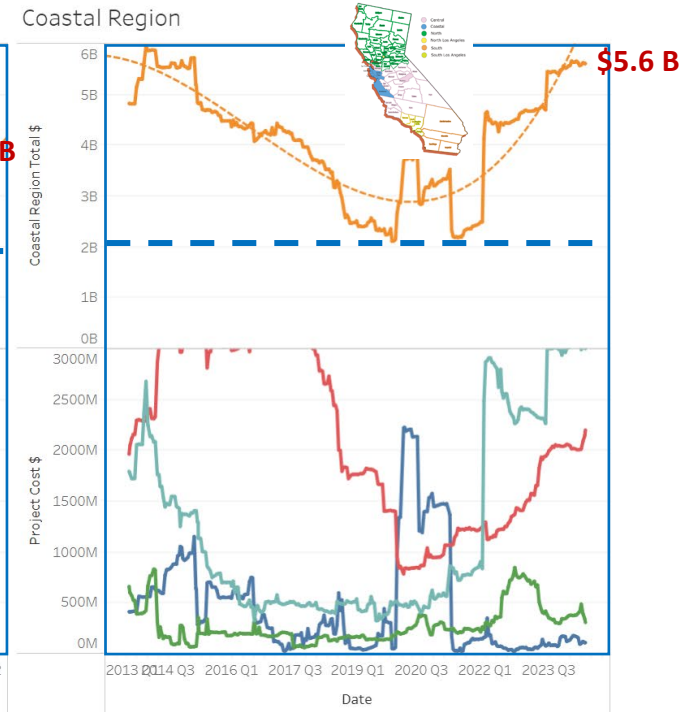
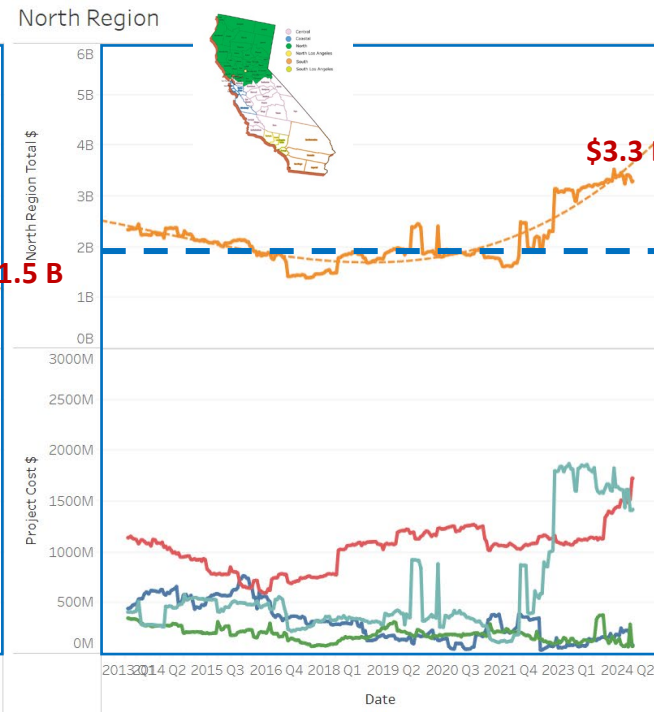
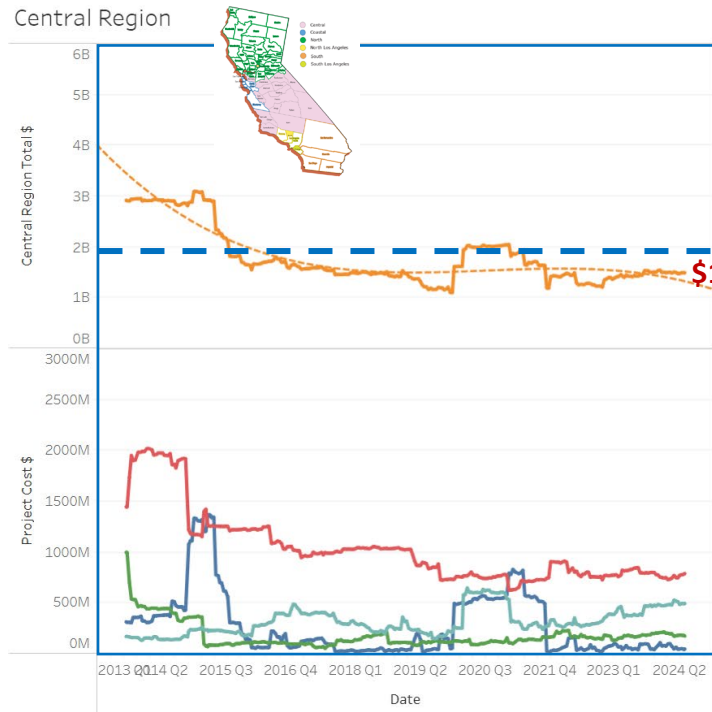

# Anticipated Plan Approval Date

Year over Year Comparison of Records Meeting or Beating APAD (Data as of 6/11/2024 6:06:19 AM):

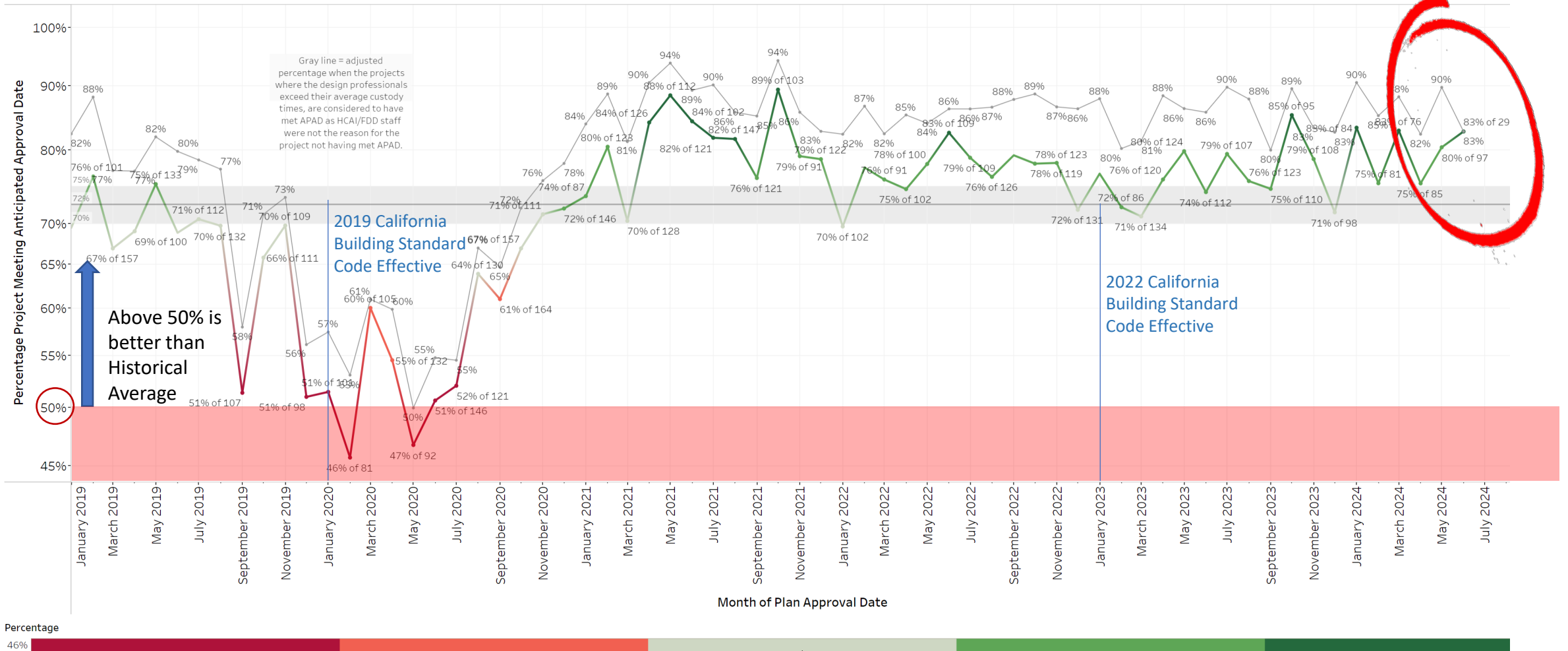



# Change Order Analysis

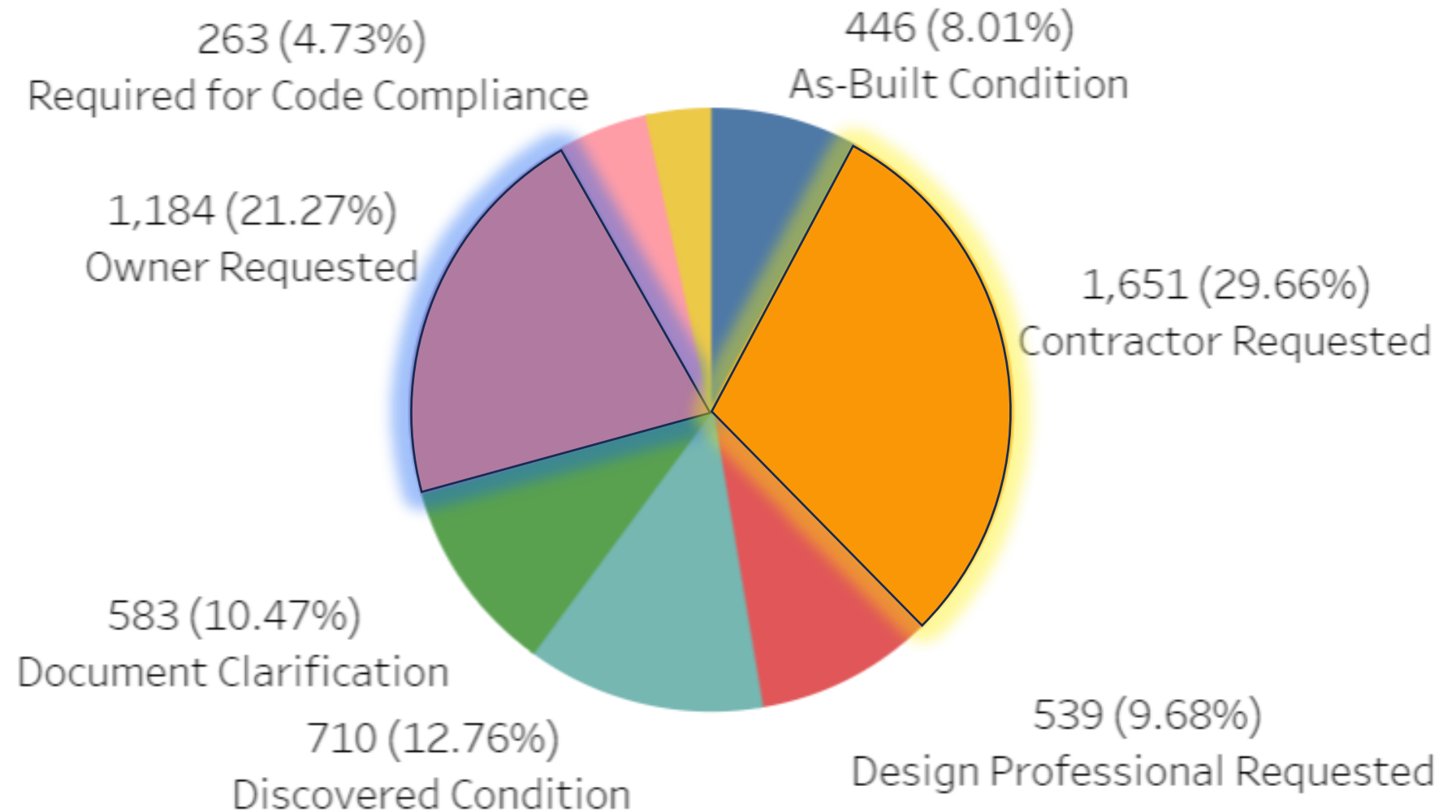

Goal	Emphasis	Sub-Goals	Objectives	Measure/Target	Data Source	Frequency	Coordinator
<b>Goal #1</b> Deliver Valuable Public Service - Deliver Timely, Quality Customer Service & Experience	22%	1.1.0 Add value to the design and construction of healthcare projects	1.1.0.1 Increase completed Quality of Service surveys to 25% of services	25% completion rate/Yr	eSP	Yearly	OSHDP Execs
			1.1.0.2 Supervisors to assess how each of their staff adds value from the clients perspective to each project		QA/QC And Surveys	Quarterly	DDCs
		1.1.2 Develop and implement procedures and enforceable building standards to ensure safe and sustainable healthcare facilities	1.1.2.1 Number of building standards, PINs, CANs and processes that have HBSB input prior to submittal to Building Standards Committee. Target - 90%	90% completion rate	Regs Unit	Yearly	BSU/Tech Leads
		1.1.3 Increase IOR Competency & Adequacy	1.1.3.1 % of Projects with Completed IOR Evaluations	90% Completion Rate	eSP	Quarterly	ISU
			1.1.3.2 IOR training – Target 2 seminars per year per location	2 Per year	Inspection Services	Yearly	ISU
			1.1.3.3 IOR training – Target 2 videos or webinars per year	2 Per year	Inspection Services	Yearly	ISU

- IOR Daily Report
- IOR Web Page

**IOR DAILY REPORT TEMPLATE**

This is a voluntary template. IOR(s) that would like to use their own format need provide the template's content as stipulated in the regulations.

Date: \_\_\_\_\_  
 Time: \_\_\_\_\_ Arrival; \_\_\_\_\_ Departure  
 Inspector of Record (IOR): XXXXXXXX  
 Certification No.: XXXXXX  
 HCAI Project No.:

*The purpose of the IOR Daily Report is to "maintain field records of construction progress for each day or any portion of a day that they are present at the project site location". 2022 CAC 7-145*

1. Summary of work in progress CAC 7-145(a)6:  
XXXXXXXXXXXXXXXXXXXX
2. Note deficiencies in the construction CAC 7-145(a)6:  
XXXXXXXXXXXXXXXXXXXX
3. Note deviations from the approved construction documents. CAC 7-145(a)6:  
XXXXXXXXXXXXXXXXXXXX
4. Inspections performed, TIO Reference #. CAC 7-145(a)4:  
XXXXXXXXXXXXXXXXXXXX
5. Document the time and date of all significant correspondence with the contractor regarding incomplete work, potential deficiencies or deviations which require the contractor's attention and could potentially affect the timely and compliant completion of the project. CAC 7-145(a)6:  
XXXXXXXXXXXXXXXXXXXX
6. List of notification to the contractor, in writing, of deviations from the approved construction documents or new construction not in compliance with the California Building Standard Codes, which have not been immediately corrected by the contractor. CAC 7-145(b)  
XXXXXXXXXXXXXXXXXXXX
7. Document the date, time and method of correction for any noted deficiencies or deviations. CAC 7-145(a)6:  
XXXXXXXXXXXXXXXXXXXX
8. If Applicable, provide copies of all certificates, tags, marks or other evidence of material properties and/or manufactured components as required by the California Building Standards Code. CAC 7-145(a)6A.  
XXXXXXXXXXXXXXXXXXXX
9. Concrete record, if applicable, including time and date of placing concrete, time and date of removal of forms and shoring in each portion of the structure, location of defective concrete, and time, date and method of correction of defects. CAC 7-145(a)6B.  
XXXXXXXXXXXXXXXXXXXX
10. Identification marks of welders, lists of defective welds, and manner of correction of defects and other related events, as applicable. CAC 7-145(a)6C.



# Training Programs in the Works

- Responsibilities and Competences of HCAI/OSHPD Compliance Officers to Observe the Construction of Hospital Projects
  - ISU commissioned to improve OSHPD consistency in the field throughout the state
- The Design Professional's Role During the Construction of Hospital Projects
  - Training
  - Certification



# California Administrative Code Requirements

- 7-141 Excerpt

(e) The testing program shall identify materials and tests to be performed on the project. The approved agency and/or individual(s) to perform each of the required tests shall also be identified. The testing program shall include, at a minimum, those tests required by applicable sections of the *California Building Standards Code*.

(f) The inspection program shall include a completed application for inspector(s) of record for the project. If a project has more than one inspector of record, the distribution of responsibilities for the work shall be clearly identified for each inspector of record.

(g) The inspection program shall also identify all special inspections to be performed on the project along with approved agency and the individual(s) to perform the inspections. The special inspections shall include, at a minimum, those special inspections required by applicable sections of the *California Building Standards Code*.

(h) The observation program shall identify each design professional that must, through personal knowledge as defined in Section 7-151, verify that the work is in compliance with the approved construction documents.

# Observed Practice in Hospital Construction Projects

- “Observation” is used interchangeably by IORs and Special Inspectors through out the state health care projects in
  - Inspection forms
  - Inspection reports
- Growing perception that this is an acceptable practice
- Approved Agencies have also demonstrated the use of this nomenclature in their work

# Goal

- To enforce the use of appropriate terminology that is consistent with the California Administrative Regulations
- To Eliminate increasing confusion regarding interchangeable terms within the regulations by consistent enforcement by OSHPD Field Staff

# Design Professional's Role in Construction

## 3-Parts to the DPOR Certification - Construction Administration Proficiency (CAP) Training

### Webinar – Part 1: June 6, 2024

- Preconstruction TIO Formulation
- Construction Kick-off meeting with OSHPD/HCAi
- Earn Personal Knowledge on Site through DPOR Site Visits

### Webinar – Part 2: July 11, 2024

- Manage ACD & NMA logs, distribution & submittals
- Learn to create NMA application
- Learn to create & submit Amended Construction Documents

### Written Exam on California Administrative Code

- Offered in Los Angeles & Sacramento 2 times/yr
  - August
  - January
- Upon completion, professionals who pass receive AIA Credits & Listed on HCAi website





# Wildfires



PSPS

# Earthquakes



# EOC Update A Quiet Year?

Emergency  
Operation  
Center

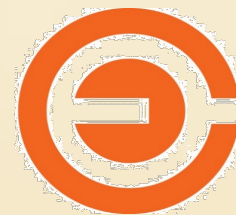

**HCAi**  
Department of Health Care  
Access and Information



# Wild-fires

- Crystal Fire, St. Helena Fire
- Point Fire
- Thompson Fire, Oroville
- Tehachapi Valley Fire
- Park Fire
- ...

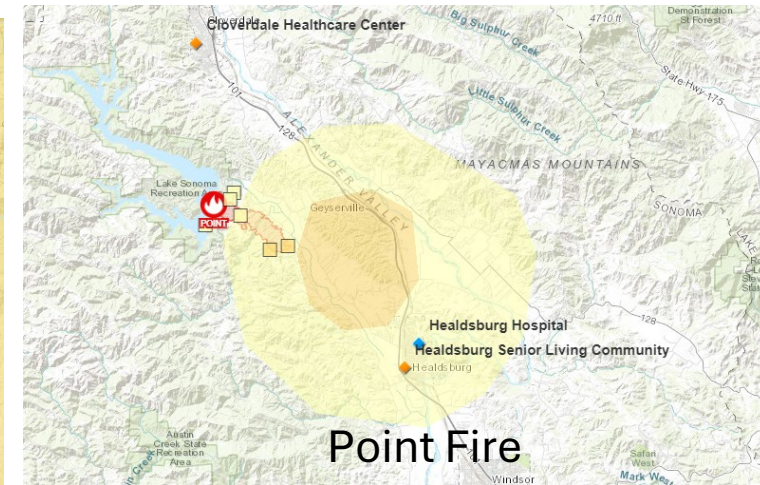
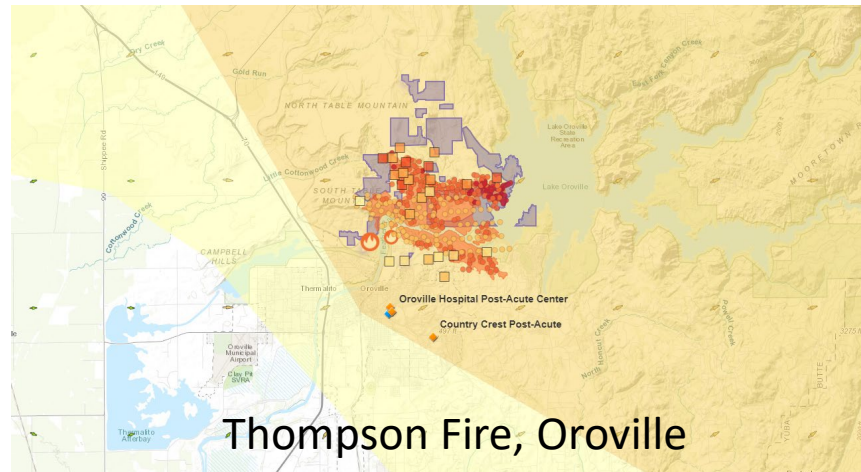
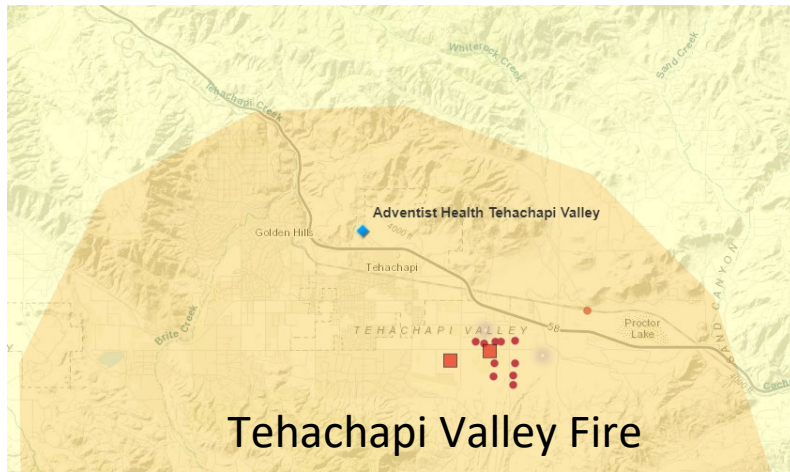
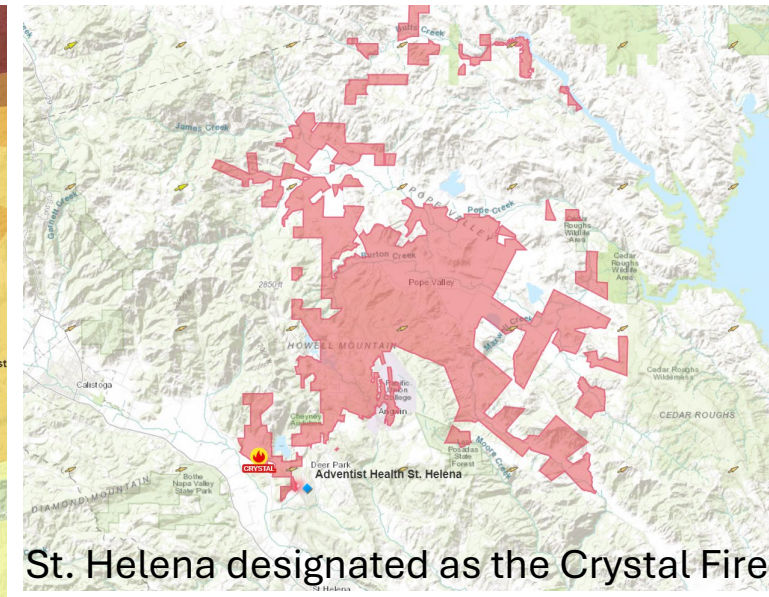
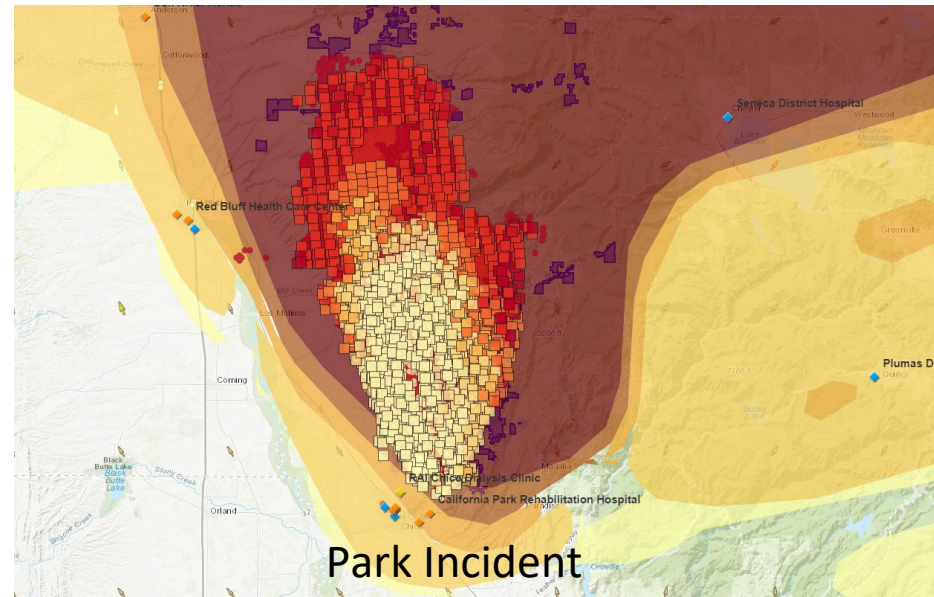



# Spotter Camera Network

UC San Diego

Search cameras

All Cameras Active Cameras

Menu Tutorial Video Login

Map Satellite

Search address or coordinates

Icons

- View Access
- View Access (AWF)
- Move Access
- Stationary Camera
- Offline < 24hrs
- Offline > 24hrs
- Start Location
- Current Location

Auto Targets

- < 5 min
- < 15 min
- < 1 hr
- < 2 hr
- < 3 hr
- > 6 hr

ALERTCalifornia UC San Diego

IMAGE COURTESY OF PG&E

Rattlesnake Peak 2 Lesnakepeak2 elev:2165' X:+78.84 Y:+0.63 Z:1.0 © ALERTCalifornia 2024/08/12 17:34:41.51

Last Moved: 3d 19h 51m

UC San Diego

IMAGE COURTESY OF PG&E

UC San Diego

IMAGE COURTESY OF PG&E

UC San Diego

IMAGE COURTESY OF PG&E

UC San Diego

IMAGE COURTESY OF PG&E

UC San Diego

IMAGE COURTESY OF PG&E

UC San Diego

IMAGE COURTESY OF PG&E

Tuscan Butte 2 Last Moved: 33m

Platte Mtn 1 Last Moved: 2h 10m

Pine Creek Last Moved: 2h 28m



# Live View Cameras

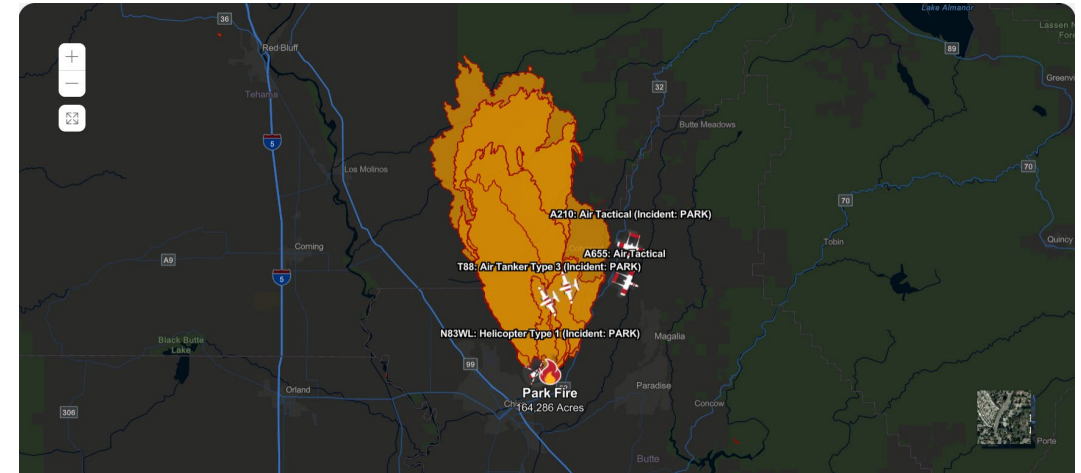
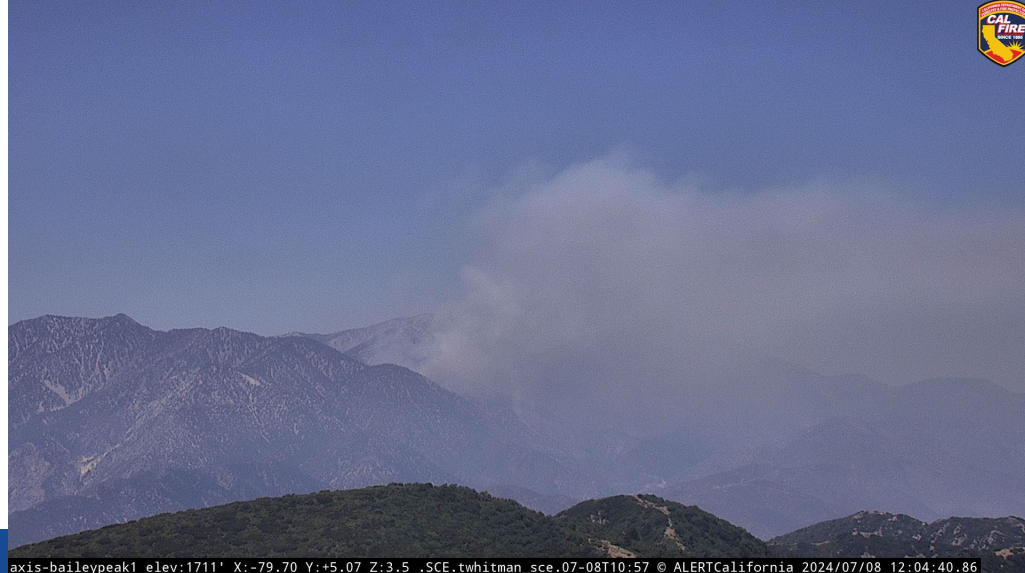
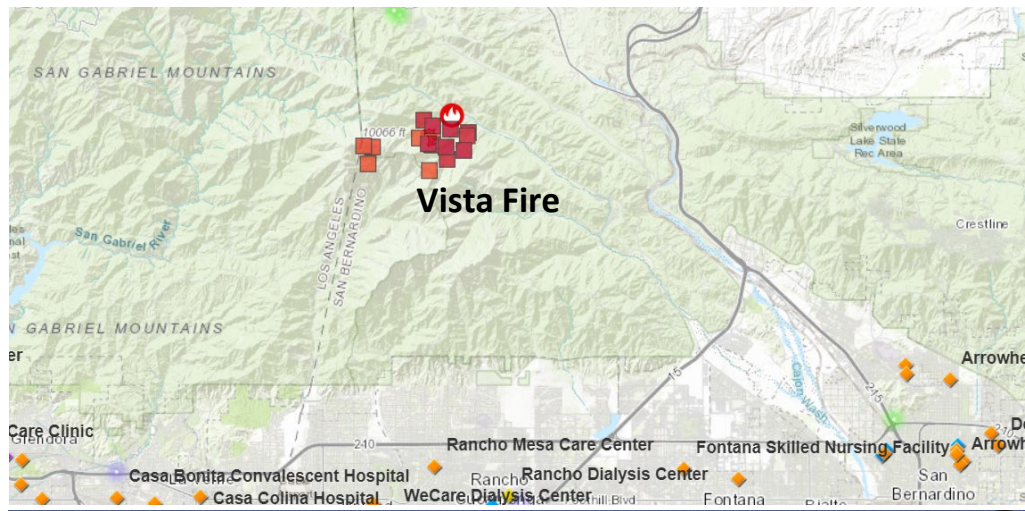



# HCAI Repopulation Visits



**27779 - Country Crest Post-Acute** Cleared for repopulation by HCAI field staff and CDPH 7/5/2024



**20015 - Feather River Care Center** Cleared for repopulation by HCAI field staff and CDPH 7/5/2024

# M5.2 Earthquake Near Bakersfield

August 6, 2024

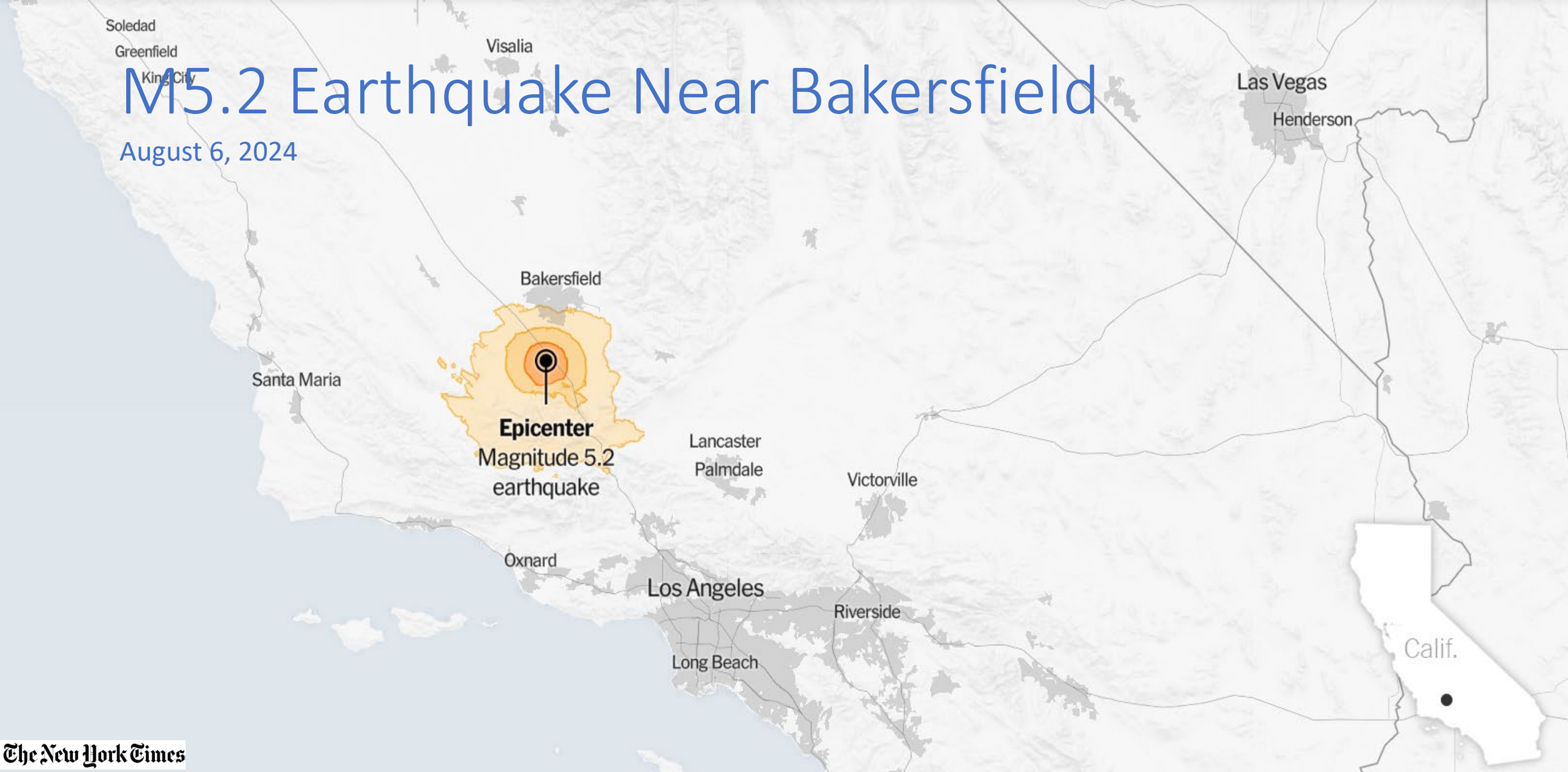

The New York Times

# M5.2 Earthquake Near Bakersfield

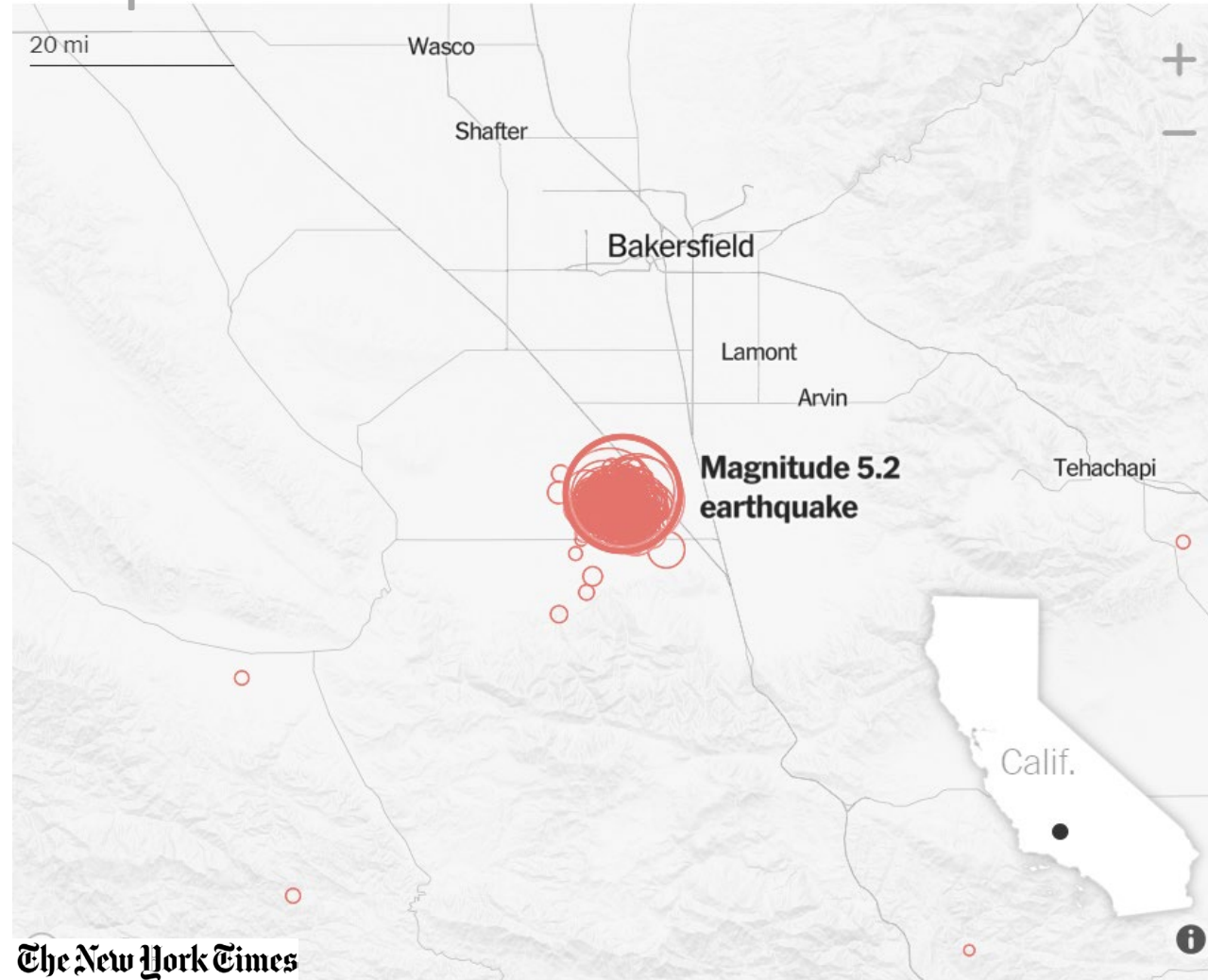



# M5.2 Earthquake Near Bakersfield

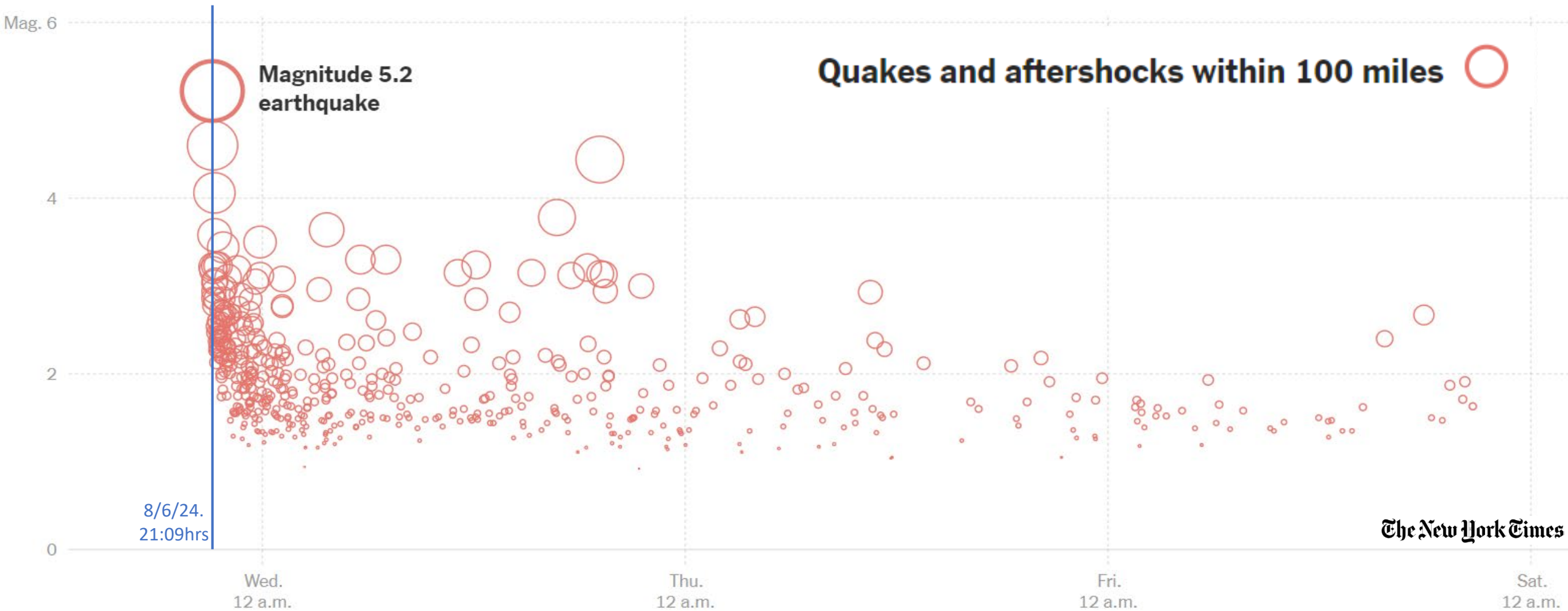

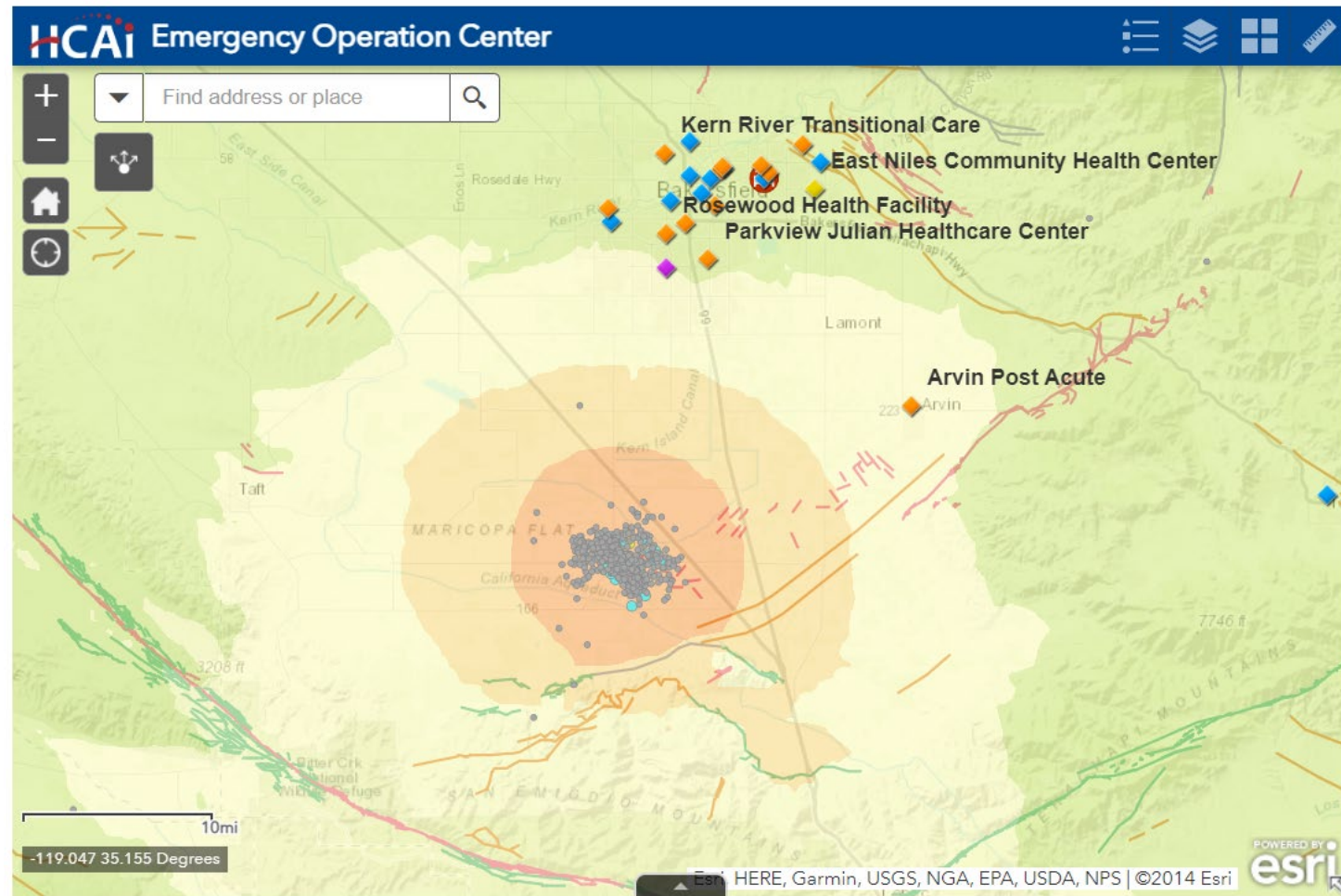

### OSHPD Facility List

- General Acute Care
- Acute Psychiatric Hospital
- Skilled Nursing and Intern. Care Facility
- Licensed Clinic

### OSHPD Facility List

- General Acute Care
- Acute Psychiatric Hospital
- Skilled Nursing and Intern. Care Facility
- Licensed Clinic

### USA Current Wildfires - Current\_Perimeters

### USA Current Wildfires - Current\_Incidents

Classify by Acres

- 1,000,000 Acres or more
- 500,000 - 999,999
- 100,000 - 499,999
- 50,000 - 99,999
- 10,000 - 49,999
- 5,000 - 9,999
- 1,000 - 4,999
- 300 - 999
- 100 - 299
- 10 - 99
- 0.26 - 9
- < .25 Acres

### National Weather Service Smoke Forecast

- 0 - 3
- 3 - 25
- 25 - 63
- 63 - 158
- > 159
- others

### California Public Utilities Commission Fire Threat Map Tier 2 (Elevated Risk)

### California Public Utilities Commission Fire Threat Map Tier 3 (Extreme Risk)

### Power Outage Areas - Source CalOES

### Power Outage Incidents - Source CalOES

### Power Outages by County - Source CalOES

### Recent Earthquakes - Events by Magnitude

Magnitude

- Meg 7.5 or >
- Meg 6 to 7.5
- Meg 4.5 to 6
- Meg 3 to 4.5
- Meg < 3

### Recent Earthquakes - Shake Intensity

Intensity Value

- X- (Extreme)
- IX (Violent)
- VIII (Severe)
- VII (Very Strong)
- VI (Strong)
- V (Moderate)
- IV (Light)
- III - II (Weak)
- I (Not Felt)

### Earthquake Faults

Quaternary Faults

Linear Faults

- Class B years
- Less than 1,600,000 years
- Less than 750,000 years
- Less than 130,000 years
- Less than 15,000 years
- Less than 150 years
- Unknown

Areal Faults

- Less than 1,600,000 years
- Less than 15,000 years
- Various
- No data

HCAI EOC Maps Full Screen

<https://hcai.ca.gov/facilities/building-safety/seismic-compliance-and-safety/emergency-response-operations/>



# California's Climate Commitment

CALIFORNIA'S CLIMATE PLAN  
LAYS THE ROADMAP TO 2045

- 2006: AB 32 Global Warming Solutions Act of 2006
  - Reduce its greenhouse gas (GHG) emissions to 1990 levels by 2020
- 2021: Governor Newsom Signs Climate Action Bills to Tackle the Climate Crisis and Protect Vulnerable Communities
- 2022: California Releases World's First Plan to Achieve Net Zero Carbon Pollution
- 2023: Governor Newsom Unveils New Proposals to Build California's Clean Energy Future



**CALIFORNIA CLIMATE COMMITMENT**  
New, World-Leading Climate Action

- The California Climate Commitment, Governor Newsom's comprehensive plan to:
  - Cut pollution, transition away from big oil
  - Deliver clean, reliable, and affordable energy
  - Save Californians money and create prosperous communities

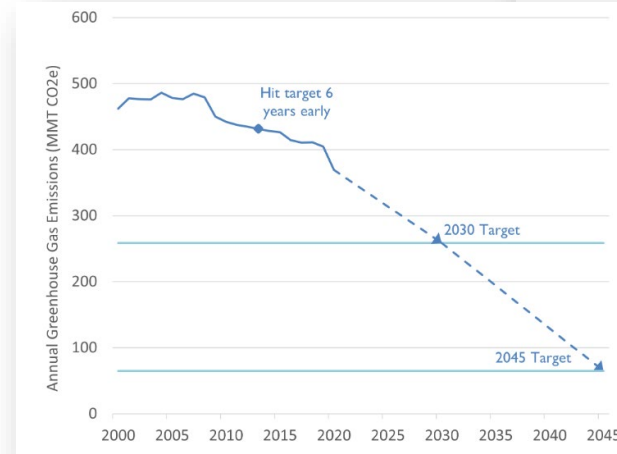

and accelerating the transition away from big polluters, Governor to the most robust, comprehensive climate action in history – the commitment invests **\$54 billion to fight climate change** and enacts new that **cut pollution, deploy clean energy and new technologies, and m harmful oil drilling**

nt will:  
tion by 71%  
use gas emissions 85% by 2045  
oil consumption to less than one-tenth of what we use today, a 94% drop  
and 86% drop in demand for all fossil fuels  
in new jobs  
ns \$200 billion in health costs due to pollution

**ING CLIMATE ACTIONS**  
AB 1279 establishes a clear, legally binding, and achievable goal for statewide carbon neutrality as soon as possible, and no later than 2045, emissions reduction as part of that goal.  
**IC GRID:** SB 1020 creates clean energy targets of 90% by 2035 and 95% by state's trajectory to 100% clean energy by 2045.  
**POLLUTION:** SB 905 and SB 134 establish a regulatory framework for of carbon removal and carbon capture, utilization and sequestration, for the continued production of fossil fuels.  
**TIES FROM HARMFUL OIL DRILLING:** SB 1157 establishes a setback between any new oil well and homes, schools, or parks. Ensures ion controls for existing oil wells within 3,200 feet of these facilities. AB 1757 requires the state to develop an achievable carbon removal working lands.

# Impact of Climate Change on Human Health

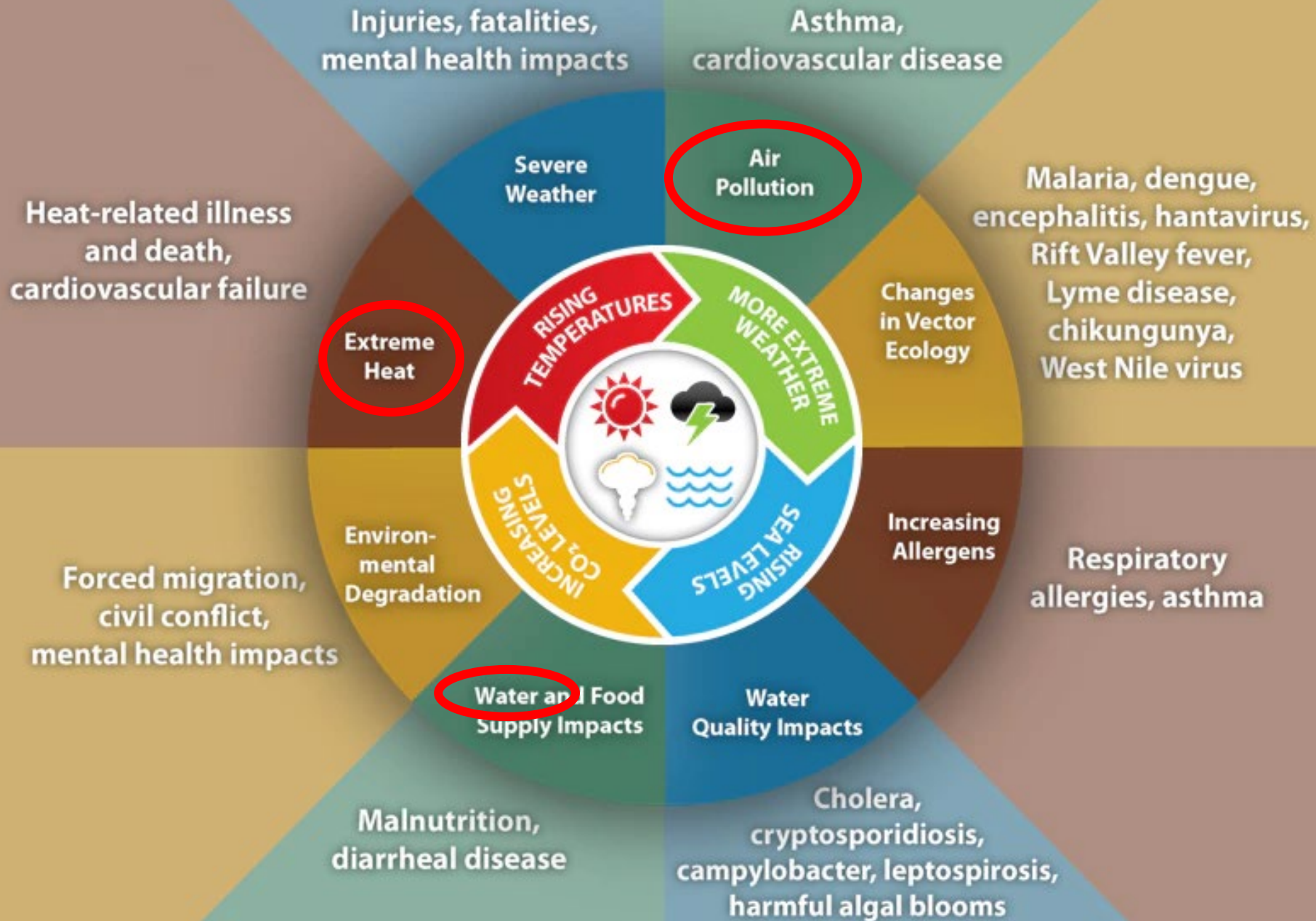

# Climate Change & Health Equity - The HCAI/OSHPD Response

- 2019 CBSC, Part 6 - Energy Code
  - Building Envelope
  - Mechanical Systems
  - Lighting systems
  - Domestic hot water systems
- Decarbonization
  - Operational Carbon
    - Microgrids
    - The all-electric hospital
    - Standard sequence of operations for ORs, ASHRAE Guideline 36
  - Embodied Carbon
- The self sufficient/sustained (“island”) Hospital
- . . .

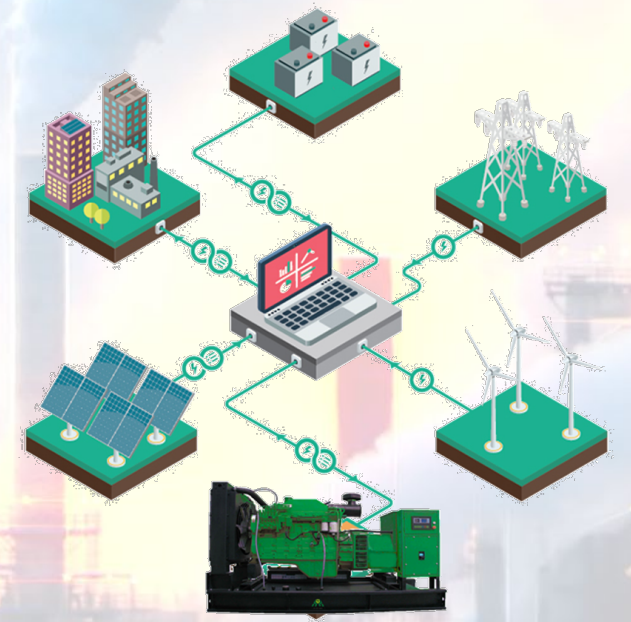
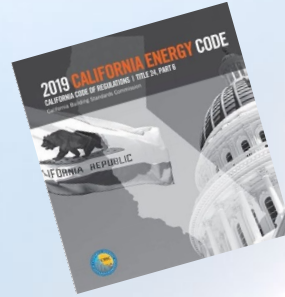





Item #14

Structural Services Section Update

- Update on Structural Services Section accomplishments year-to-date
- Discussion and public input

*Facilitator: Roy Lobo, PhD, SE, Principal Structural Engineer, HCAI  
(or designee)*

# **Office of Statewide Hospital Planning and Development**

**California's Building Department for Hospitals**

## **STRUCTURAL SERVICES SECTION UPDATE**

**Roy Lobo, Ph.D., S.E., Principal Structural Engineer**

**Ali Sumer, Ph.D., S.E., Supervisor Seismic Compliance Unit**

**HBSB Full Board Meeting**

**August 15, 2024**



# Seismic Compliance Update

(8/15/2024)

# Structure Performance Categories

OSHPD

2001\*

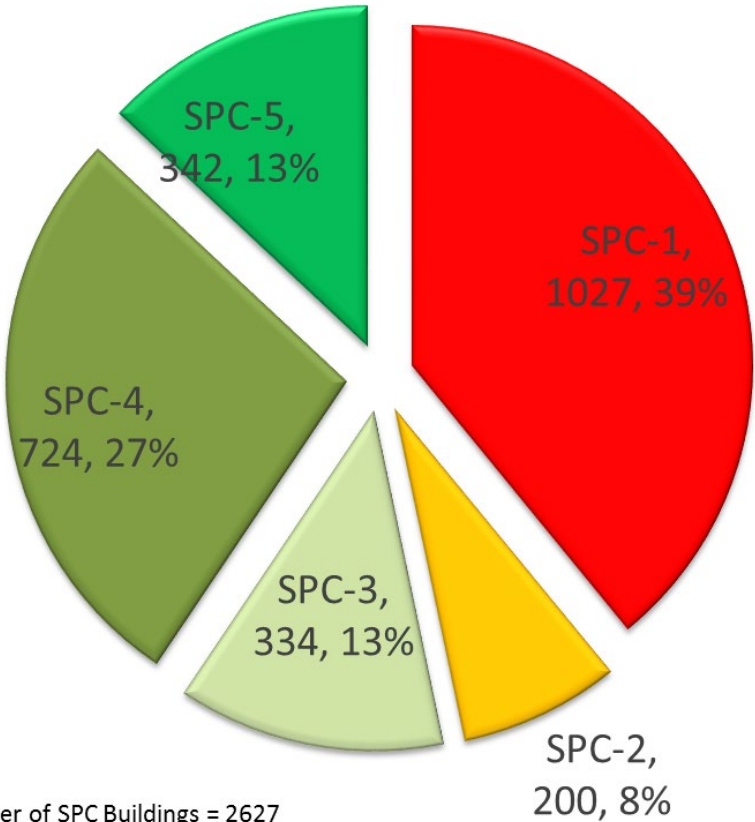

HCAi  
Department of Health Care  
Access and Information

8/9/2024\*\*

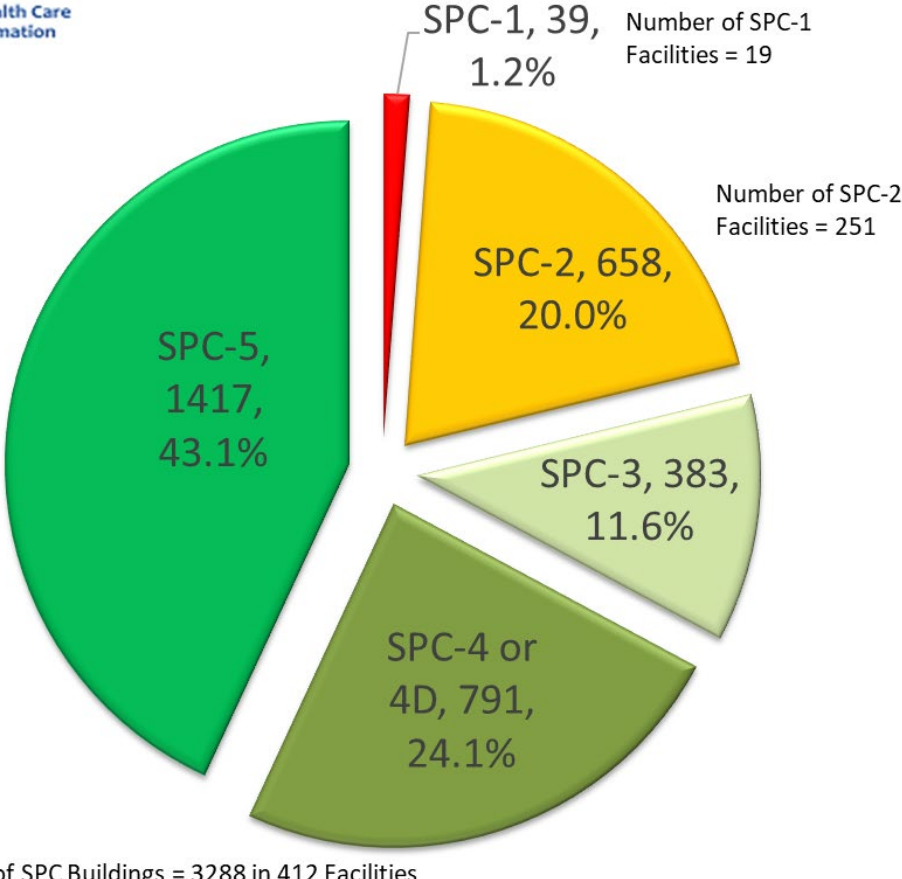

\* Based on 2001 Hospital Survey Results based on hospital "self-report" and then "state-of-the-art" FEMA 178 standards from 1996  
 \*\* SPC-5 includes buildings currently under construction  
 For SPC - "Not Assigned" is for non-building structures such as equipment yards, cooling towers etc that are still under construction

[OSHPD's Website Visualization](#)

# Structure Performance Categories Today

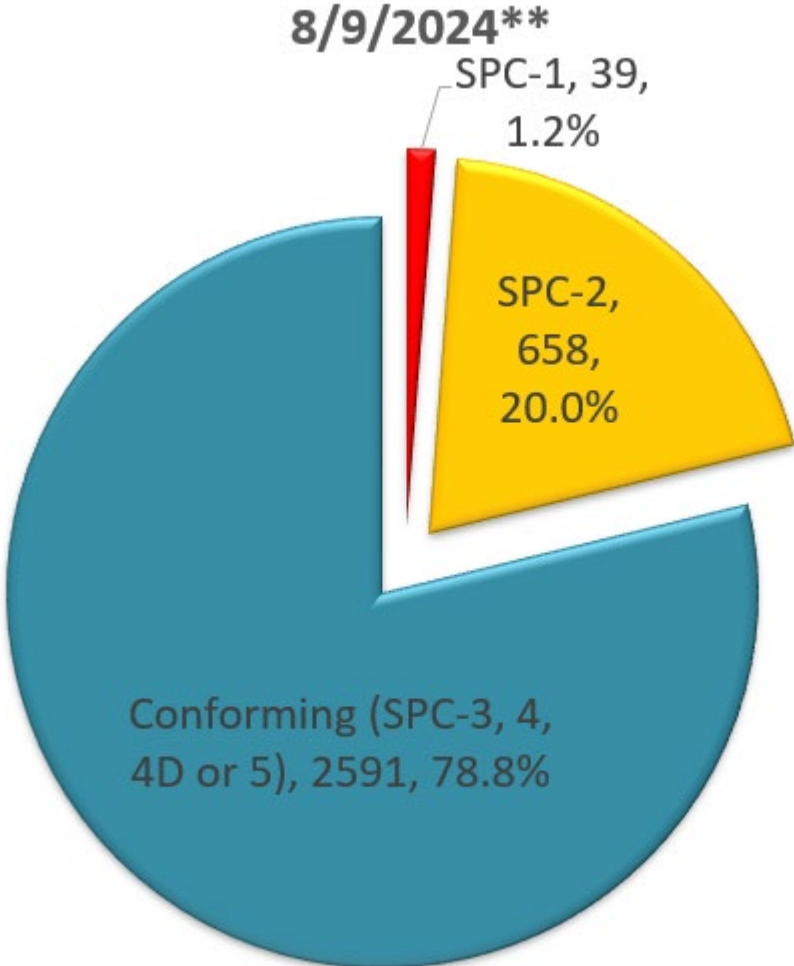

# AB 2190 Extension Categories

<del>AB 2190 Retrofit</del>	<del>Completion by July 1, 2022</del>
<del>AB 2190 Replace</del>	<del>Completion by July 1, 2022</del>
AB 2190 Rebuild:	Completion by January 1, 2025

## Facility Specific Extensions:

<del>AB 1527 Seton</del>	<del>Completion by July 1, 2023</del>
<del>SB 564 Santa Clara Valley/ O'Connor</del>	<del>Completion by July 1, 2023</del>
AB 1471 Santa Clara Valley	Completion by July 1, 2026
AB 2404 Pacifica	Completion by January 1, 2025

# AB 2190 Status

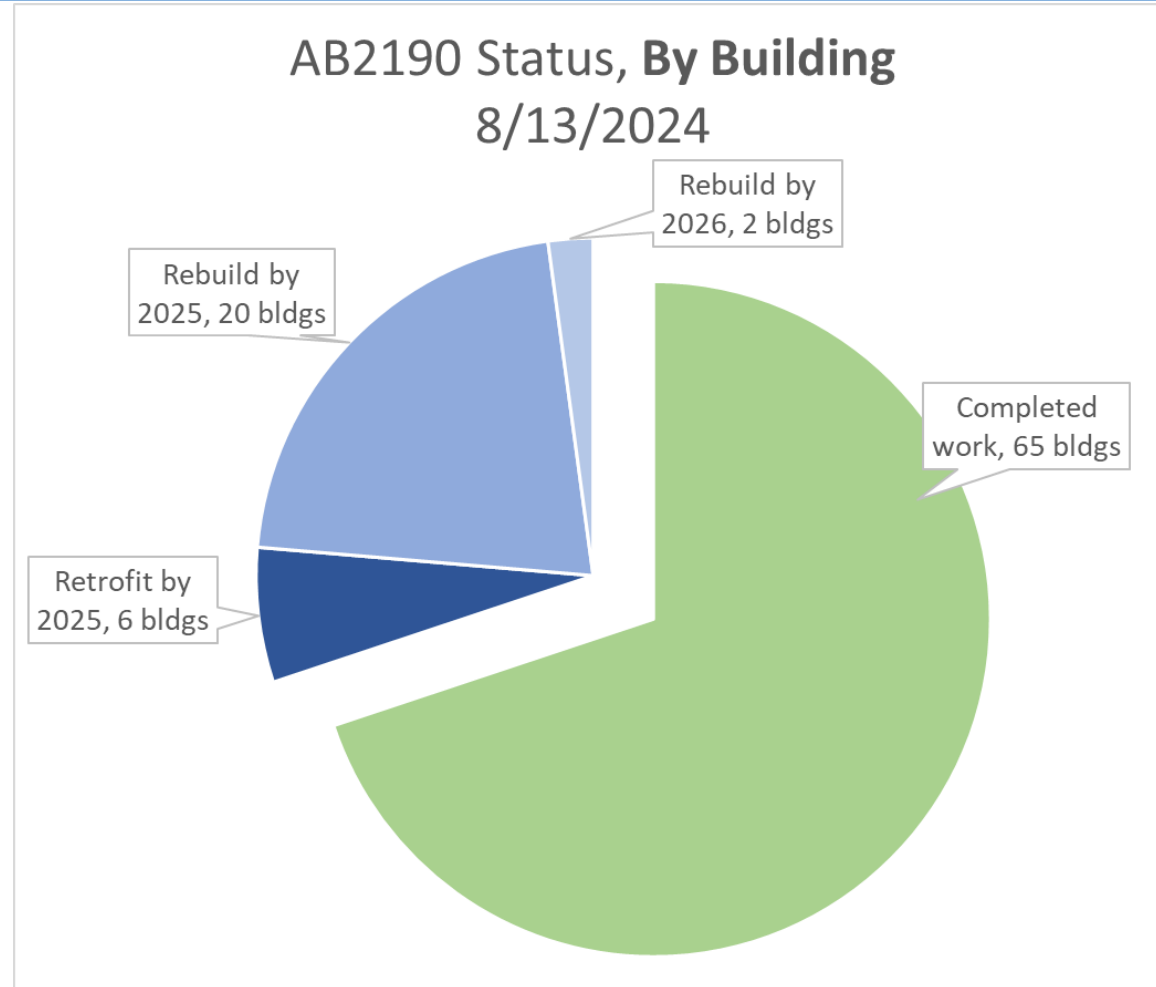

Total: 93 Buildings

# AB 2190 Status - Fines

Central Valley Specialty Hospital has been assessed penalties totaling **\$235k**

Pacifica Hospital of the Valley in Sun Valley has been assessed penalties totaling **\$1,680,000** (April 8, 2024, through July 31, 2024). Additional penalties will be assessed (~450k/month)



# Nonstructural Performance Categories

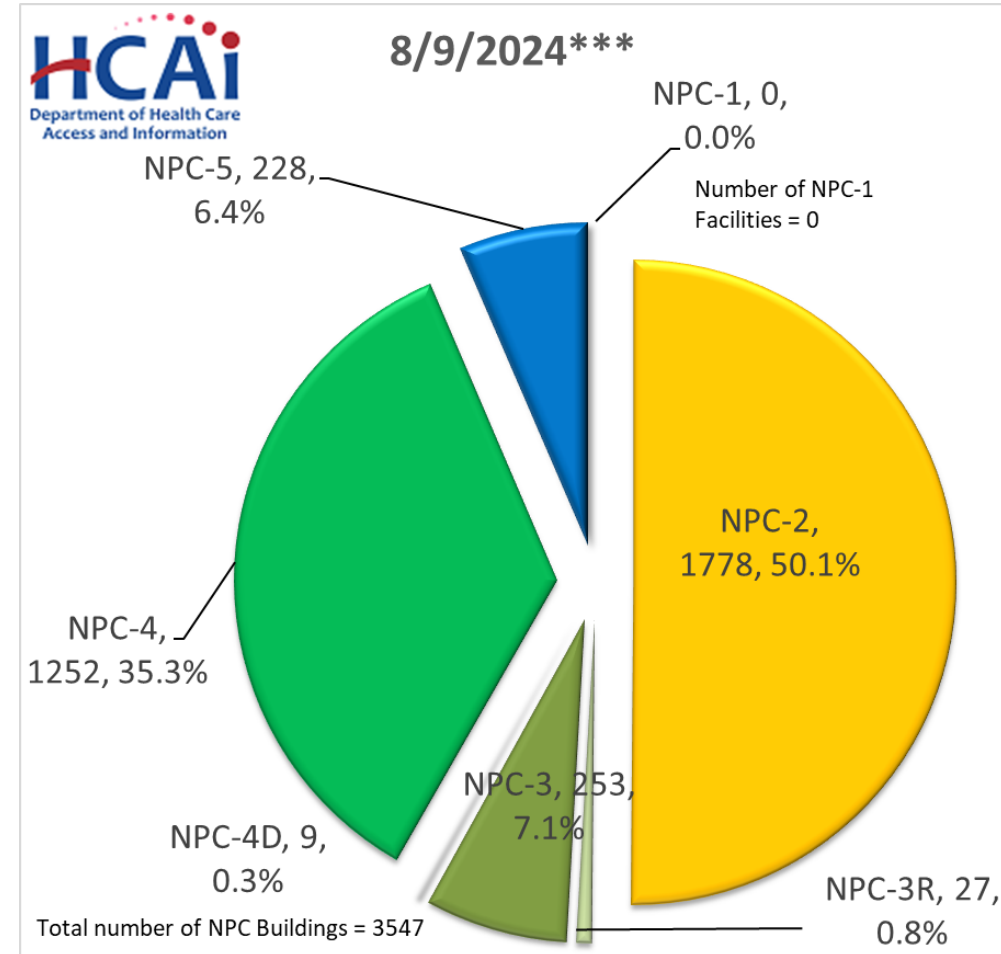
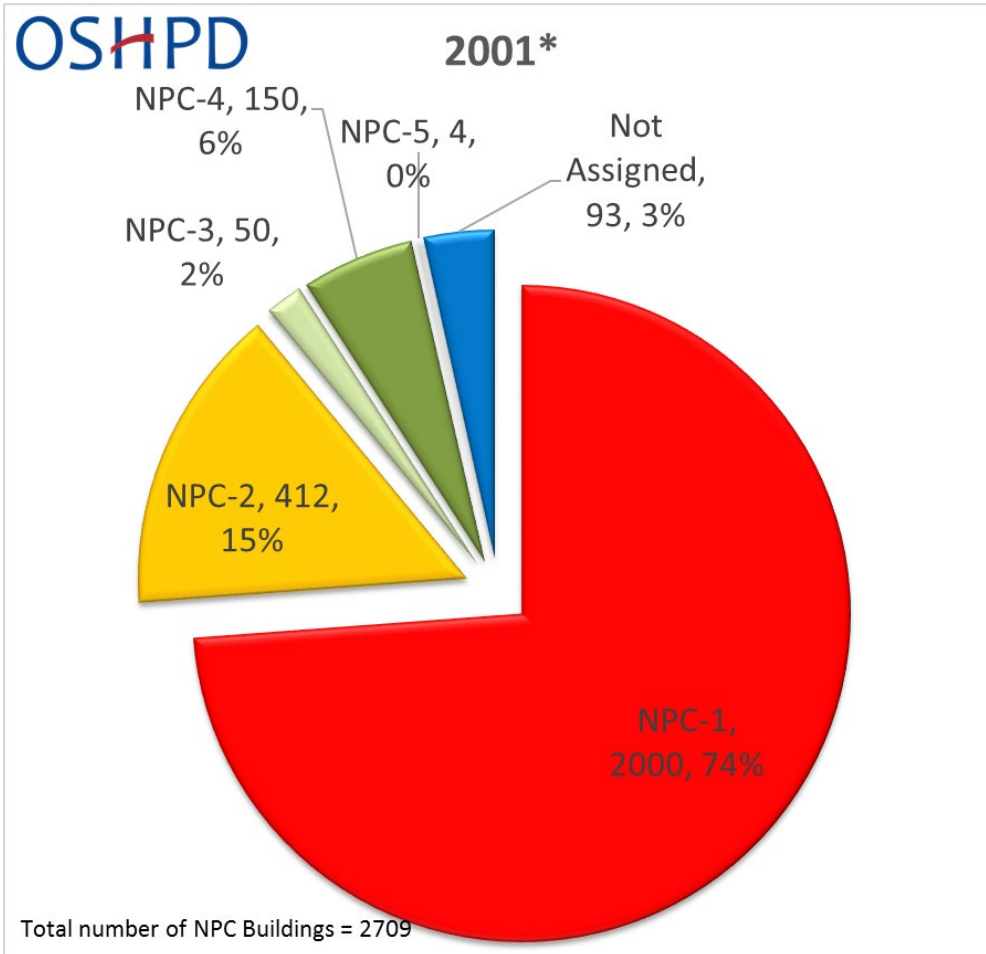

\*\*\*Includes buildings under construction, tunnels and equipment yards  
 For NPC - "Not Assigned" are for buildings and nonbuilding structures either under construction or where the nonstructural performance category has not been verified  
 Buildings under construction or just built are assigned a preliminary NPC of 4

# Seismic compliance documents/applications required to be submitted to HCAI/OSHPD by 1/1/2024:

## **NPC Submittals (Required by California Administrative Code Chapter 6)**

- NPC 3 compliance construction final document *[If GAC building is NPC 2 and located in extremely high seismic site]*
- NPC 4D Evaluation report including Operational Plan or NPC 4 Evaluation report
- NPC 5 Evaluation report including 72hr fuel evaluation and Water Rationing Plan
- Letter of Intent stating GAC services in the building will be removed by 1/1/2030 *[For GAC buildings planned to be removed from GAC services by 1/1/2030]*

## **AB 1882 Submittals**

- Licensed GAC Services Reporting Application *[[All buildings under HCAI jurisdiction ]*
- Signage Application *[All GAC Buildings]*

# NPC Evaluation Report Status – Due 1/1/2024

NPC Evaluation Report  
Submittal Status 8/13/2024  
(Building Count)

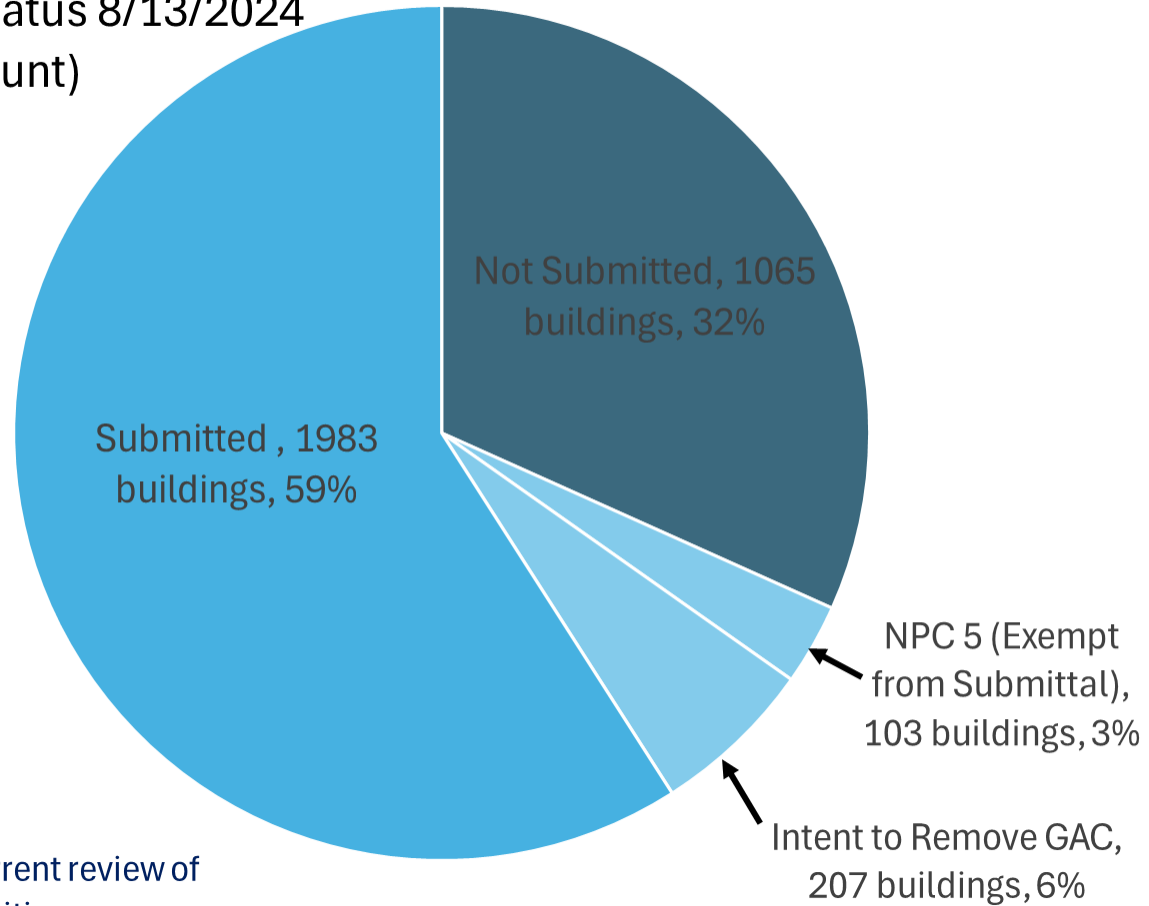

Source: HCAI current review of 407 hospital facilities.

# AB 1882- Signage Status

AB 1882 Signage Compliance  
(Building Count)  
4/7/2024

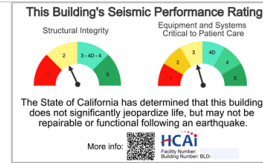
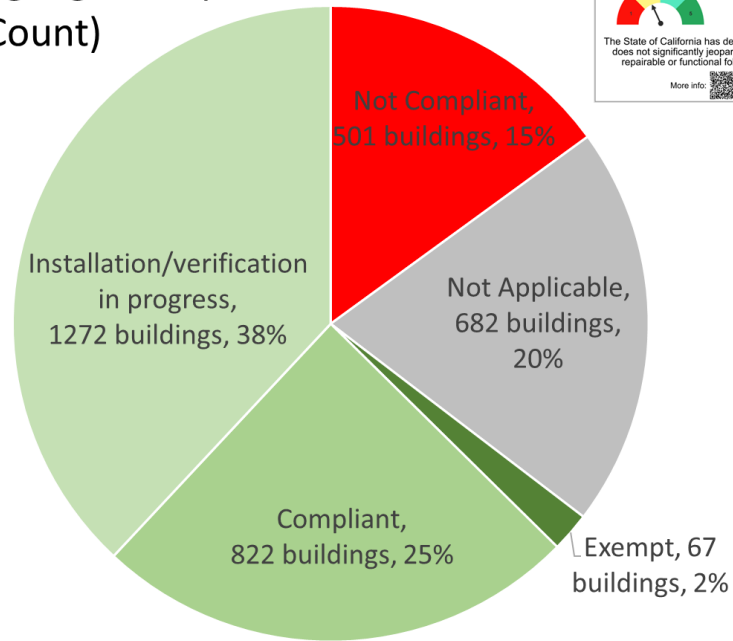

AB 1882 Signage Compliance  
(Building Count)  
8/12/2024

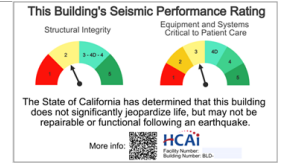
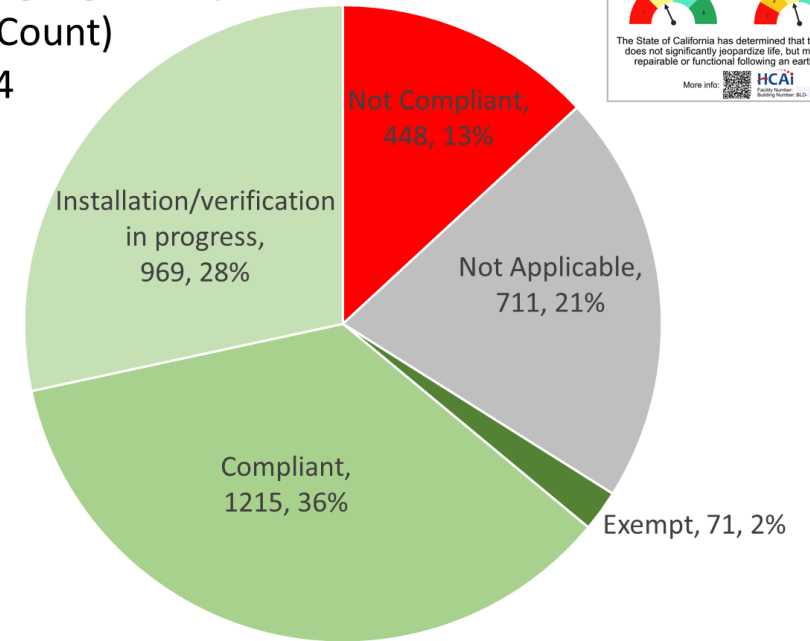

# AB 1882- Services Status

AB 1882 Services Reporting Compliance (Facility Count) 3/7/2024

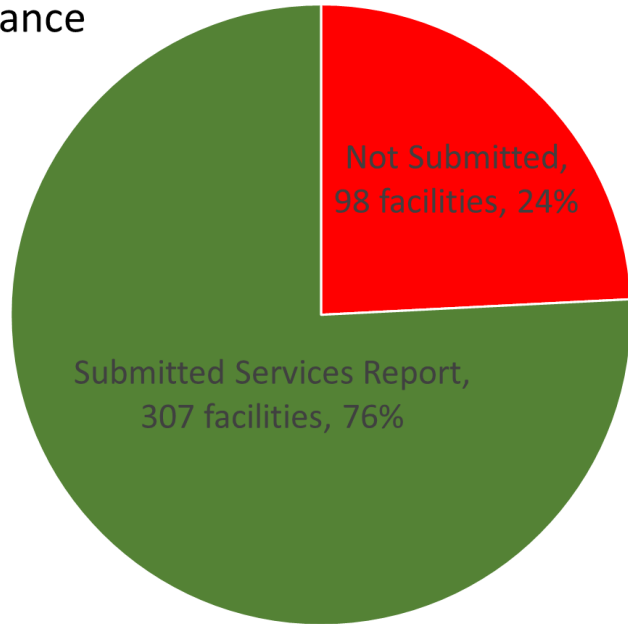

## AB 1882 Services Reporting

- Services reporting portal closed.
- Annual reporting window will open on Nov 1st for this year reporting
- Will send reminder letters to all facilities on mid September

*For accessible copies of facility site plans email [Seismic Compliance Unit](#).*

[Back to Main](#)

Applicable Year: 2023

**12295 Sharp Coronado Hospital and Healthcare Center**

BLD Num	BLD Name	Applicable Year	Nursing Med Surg	Surgical	Anesthesia PACU	Clinical Lab	Imaging Radiological Diagnostic/Imaging	Pharmacy	Dialysis	Administrative	Shell Processing	Central Storage	Reception	Employee Changing	Surrounding EYS	Support Services	ICU/CCU/PCCU	Burn Unit	Neonatal Intensive Care Unit	Pediatric Advanced Nursing Unit	Psychiatric Nursing	Chemistry Perinatal Unit	Emergency	Nuclear Medicine	Rehabilitation Therapy	Physical Rehabilitation Nursing Unit	Renal Dialysis	Respiratory	Intermediate Care	Outpatient Services	Skilled Nursing Unit	Central Plant Utility Bldg	Campus Connector Buildings/Tunnels	Non-GAC Uses	
BLD-02051	Main Tower	2023	X	X	X	X	X	X	X	X	X	X	X	X			X									X	X	X						SPC: 2 NPC: 2 This building does not significantly jeopardize life, but may not be repairable or functional following an earthquake.	
BLD-02052	ICU Building (Emergency Department Building)	2023	X														X											X						SPC: 2 NPC: 2 This building does not significantly jeopardize life, but may not be repairable or functional following an earthquake.	
BLD-02053	Ancillary Building	2023				X		X	X	X	X																			X					SPC: 2 NPC: 2 This building does not significantly jeopardize life, but may not be repairable or functional following an earthquake.
BLD-02027	Prospect Place Canopy	2023																												X					SPC: 5 NPC: 4

# NPC Report Status

- NPC report status for all facilities are continued to be published on our website. (The link is at the same location)

Two locations to check status:

Facility by facility: [Facility detail page](#)

All facilities: One file - under [seismic compliance website](#)



County Code	Facility Nbr	Facility Name	Building Nbr	Building Name	Building Status	SPC Rating*	SPC Extensions						CO/CF	HCAI NPC rating*	NPC Extensions	NPC 4/4D Status	NPC 5 Status	AB 1882 Notice
							SB 306 Extension Status	AB 523 Extension Status	SB 1661/AB 2557/AB 81 Extension Status	SB 499 Extension Status	SB 90 Extension Status	AB 2190 Extension Status						
01 - Alameda	11210	Alameda Hospital	BLD-01278	Original Hospital	OSHPD 1R-No Gen Acute Care - OSHPD Bldg	N/A	Denied											
01 - Alameda	11210	Alameda Hospital	BLD-01279	Stephens Wing	OSHPD 1-In Service	2	Denied			Withdrawn						Rpt: Submitted 12/29/2023	Rpt: Submitted 06/25/2024	This building does not significantly jeopardize life, but may not be repairable or functional following an earthquake.
01 - Alameda	11210	Alameda Hospital	BLD-01280	West Wing	OSHPD 1-In Service	2	Denied							2		Rpt: Submitted 12/29/2023	Rpt: Submitted 06/25/2024	This building does not significantly jeopardize life, but may not be repairable or functional following an earthquake.
01 - Alameda	11210	Alameda Hospital	BLD-01281	South Wing	OSHPD 1-In Service	3s								2		Rpt: Submitted 12/29/2023	Rpt: Submitted 06/25/2024	
01 - Alameda	11210	Alameda Hospital	BLD-01282	Radiology Addition	OSHPD 1-In Service	4								2		Rpt: Submitted 12/29/2023	Rpt: Submitted 06/25/2024	
01 - Alameda	11210	Alameda Hospital	BLD-01283	Medical Gas Storage	OSHPD 1-In Service	3								2		Rpt: Submitted 12/29/2023	Rpt: Not Submitted	
01 - Alameda	11210	Alameda Hospital	BLD-02630	Compactor Shed	OSHPD 1-In Service	4								2	1/1/2030	Rpt: Submitted 12/29/2023	Rpt: Not Submitted	
01 - Alameda	11210	Alameda Hospital	BLD-03120	Emergency Room Relocation	OSHPD 1-In Service	3s								2		Rpt: Submitted 12/29/2023	Rpt: Submitted 06/25/2024	
01 - Alameda	11210	Alameda Hospital	BLD-05597	LOX Tank	OSHPD 1-Equipment Yard	N/A								4			Rpt: Not Submitted	
01 - Alameda	11322	Alta Bates Summit Medical Center	BLD-00695	Ehman Building	OSHPD 1-In Service	2								2	1/1/2030	Rpt: Submitted 12/21/2023	Rpt: Submitted 12/31/2023	This building does not significantly jeopardize life, but may not be repairable or functional following an earthquake.
01 - Alameda	11322	Alta Bates Summit Medical Center	BLD-00696	North Wing	OSHPD 1-In Service	2								2	1/1/2030	Rpt: Submitted 12/21/2023	Rpt: Submitted 12/31/2023	This building does not significantly jeopardize life, but may not be repairable or functional following an earthquake.
01 - Alameda	11322	Alta Bates Summit Medical Center	BLD-00698	East Wing	OSHPD 1-In Service	2								2	1/1/2030	Rpt: Submitted 12/21/2023	Rpt: Submitted 12/31/2023	This building does not significantly jeopardize life, but may not be repairable or functional following an earthquake.
01 - Alameda	11322	Alta Bates Summit Medical Center	BLD-00699	Original West Wing	OSHPD 1-In Service	2								2	1/1/2030	Rpt: Submitted 12/21/2023	Rpt: Submitted 12/31/2023	This building does not significantly jeopardize life, but may not be repairable or functional following an earthquake.

Risk Bsd = Risk Based SB 90 extension  
 Fin Hdsp = Financial Hardship based SB 90 extension  
 Com Acc = Community Access based SB 90 extension  
 GAC = General Acute Care

Retrofit = Building will be retrofitted  
 Rebuild = GAC services will be moved to new building/s  
 Replace = GAC services will be moved to existing SPC 2 or higher building/s  
 Remove = GAC services will be removed from building

**NPC 4/4D Status:** This column shows NPC 4 or NPC 4D evaluation report submittal status.

**NPC 5 Status:** This column shows NPC 5 evaluation report submittal status.

**Rpt: Submitted** – means HCAI has received an NPC evaluation report. Submittal date is noted.

**Rpt: Not Submitted** – means HCAI has not received an NPC evaluation report.

**Rpt: Unacceptable Submittal** – means HCAI has received a document but was missing major required NPC evaluation report content. Submittal date is noted. These submittals did not comply with the NPC evaluation 1/1/2024 submittal deadline.

**Intent to Remove GAC** – means HCAI received a signed letter that the facility intends to remove this building's GAC services by 2030 and therefore NPC evaluation report is not required.

\* 3s, 4s and 5s indicate SPC/NPC rating self-reported by the hospital and not verified by OSHPD  
 \* 1s is a temporary rating assigned to seismically separate buildings created by retrofits  
 \*\* Statutory SPC 1 requirements satisfied, but building is required to be removed from GAC service or reclassified to a higher SPC rating

## NPC Upgrade Construction Process for Ceilings and Above Utilities

### Reason/Purpose:

- Limited information regarding utilities' layout and bracing conditions above the ceiling.
- Surveying these utilities often requires preparation of the space for observation, disrupting hospital operations.
- Once the survey is complete, another disruption is necessary for the upgrade construction in the same area. Opening the ceilings multiple times increases the project cost.
- The purpose of the PIN is to minimize disruption time and expedite the construction of NPC upgrades for existing components at or above ceilings.

There is NO CHANGE in NPC rules/regulations.

Coming soon.

# Draft PIN (development in progress)

## NPC Upgrade Construction Process for Ceilings and Above Utilities

### Scope

- The focus of this PIN is solely on the NPC upgrade of existing components at or above ceilings. Examples of these items are ceiling components, light fixtures, ducts, conduits, pipes, inline HVACs, hung OR lights, etc.
- Not applicable to existing equipment on the floor or on walls.
- Not applicable to installation of new utilities, new equipment, which require separate usual applications per the typical HCAI process. These new utilities or equipment shall not be identified as NPC upgrade project.

More to follow...

# Seismic Compliance Plan

- There is already eSP electronic application process (SCR-2024-00xxx record type)

2030 Building Matrix							
Bldg Num	Bldg Name	SPC	NPC	Code	Permit	Bldg Type	Stories
BLD-00513	Main Hospital Building	4D	4D, 5	1961 UBC	UNKNOWN	01 - Wood, Light Frame	1
BLD-00514	Mechanical Building	4D	4D, 5	1961 UBC	UNKNOWN	01 - Wood, Light Frame	1
BLD-00515	Rec. Room & Office Addition	4D	4D, 5	1967 UBC	UNKNOWN	01 - Wood, Light Frame	1
BLD-05681	Generator Shed	4D	4D, 5	1961 UBC	UNKNOWN	23 - Inverted pendulum - Steel Moment Resisting Frame	1
BLD-00516	Lab & Storage Addition	4	4D, 5	1979 UBC	H1151	01 - Wood, Light Frame	1
BLD-00517	Canopy Addition	4	4, 5	1979 UBC	SS880101	08 - Concrete Moment Resisting Frame	1
BLD-00518	Birthng Center	5	4, 5	1995 CBC	HS971863	04 - Steel Braced Frame	1
BLD-02949	LDR Addition	5	4, 5	2007 CBC	HS071499	03 - Steel Moment Resisting Frame	1
BLD-05522	ER / Radiology / Clinic Addition	5	4, 5	2001 CBC	HS031721	03 - Steel Moment Resisting Frame	1
BLD-06036	Lobby Remodel & Addition	5	4, 5	2001 CBC	HS031721	03 - Steel Moment Resisting Frame	1
BLD-06037	Corridor Addition	5	4, 5	2001 CBC	HS031721	03 - Steel Moment Resisting Frame	1
BLD-06038	Mechanical & Electrical Building Addition	5	4, 5	2001 CBC	HS031721	14 - Reinforced Masonry Bearing Walls-Concrete Diaphragm	1
BLD-06039	Main Entrance Canopy Addition	5	4, 5	2001 CBC	HS031721	03 - Steel Moment Resisting Frame	1
BLD-06040	ER Canopy Addition	5	4, 5	2001 CBC	HS031721	03 - Steel Moment Resisting Frame	1

Table 2: 2030 Building Construction Matrix

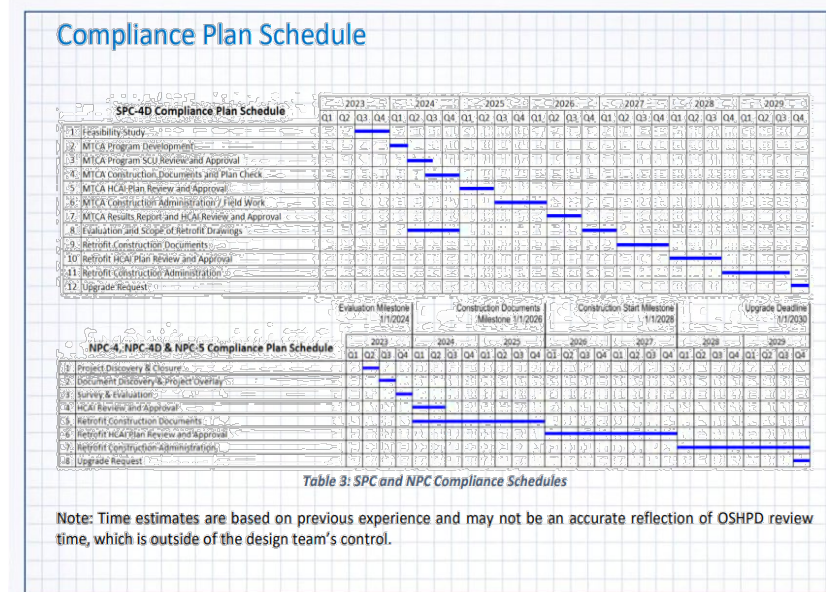

- A more robust & input data friendly design is in development.

# SRHRP - Update

## Small and Rural Hospital Relief Program

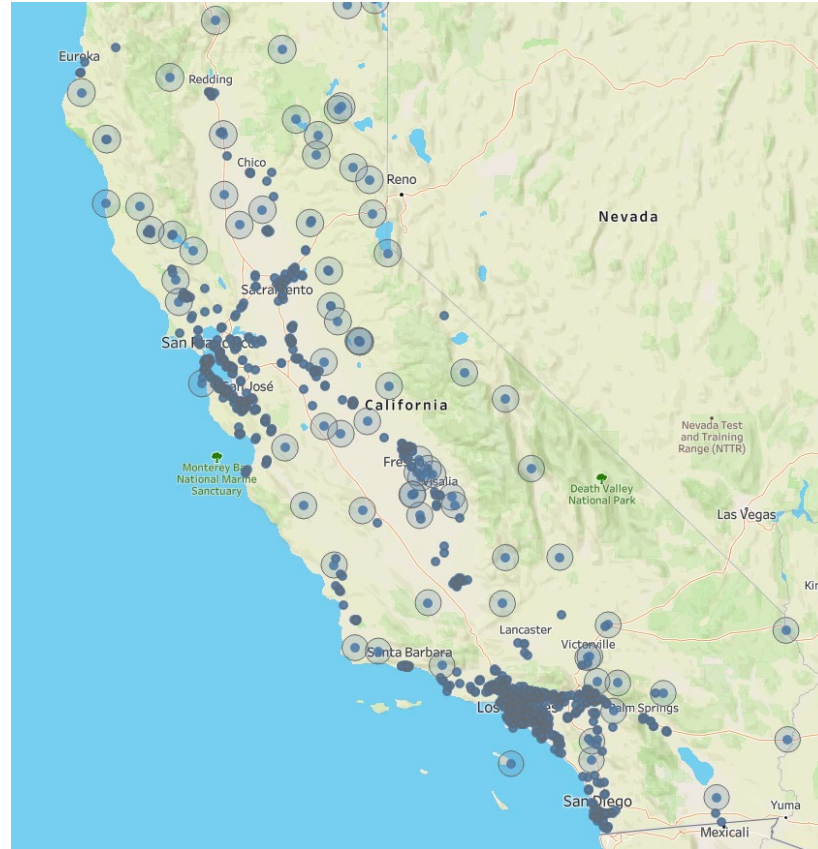

- **\$1,085,000** awarded to date:
  - \$280K Mee Memorial Hospital
  - \$180K Kern Valley District
  - \$625K approved – Mad River NPC-3
  - In review: Oak Valley and Plumas districts
- **\$7.2M** transferred into Fund 3391 total to date
- 38 Applications Received
- 26 Eligibility Approved, 12 Pending Finalization, one not eligible

# Structural Support Unit Update



# Overview

- OSHPD preapproved programs
- Structural/Nonstructural California amendments
- Geotechnical reviews
- Seismic instrumentation
- Structural training and support to the regions
- Management of contract out plan reviews
- Other Activities

# Types of Preapprovals

## Preapproval Programs

HCAi Office of Statewide Hospital Planning and Development (OSHPD) has five distinct preapproval programs that operate under the Structural Support Unit (SSU) and Inspection Services Unit (ISU).

### OSHPD Preapproved Agency (OPAA)

Preapproval of Agencies that provide Structural Tests and Special Inspection services used in California healthcare facility construction.

[LEARN MORE](#)

[VIEW PIN 58](#)

### OSHPD Preapproved Details (OPD)

Preapproved standard architectural and engineering details developed by HCAi/OSHPD for use in California healthcare facility construction.

[LEARN MORE](#)

[VIEW PIN 51](#)

### OSHPD Preapproval of Manufacturer's Certification (OPM)

Preapproval of seismic design of supports and attachments for nonstructural components used in California healthcare facility construction.

[LEARN MORE](#)

[VIEW PIN 62](#)

### OSHPD Special Seismic Certification Preapproval (OSP)

Preapproval of special seismic certification of non-structural components used in California healthcare facility construction.

[LEARN MORE](#)

[VIEW PIN 55](#)

### OSHPD Preapproved Prefabricated Components and Systems (PCS)

Preapproval of prefabricated components and systems used in California healthcare facility construction.

[LEARN MORE](#)

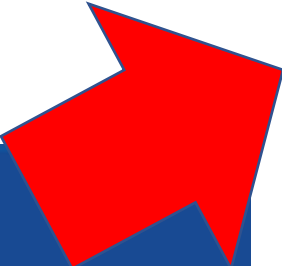

# OSP – Special Seismic Certification Preapproval

(Equipment Qualified by Shake Table Testing)



# OSP Triannual Period Status

## Current OSP Status\*

Total OSP's, 790

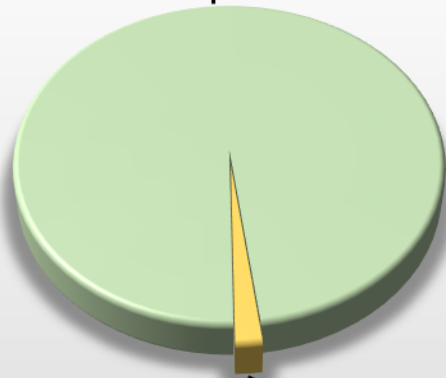

Current Submittals, 15

\*As of end of last triannual period.

## Current OSP Submittal Status\*

Remarked, 14

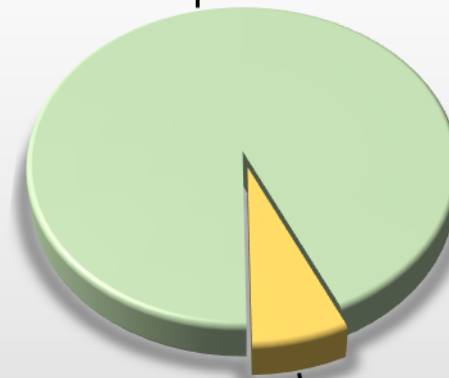

In Review, 1

\*As of end of last triannual period.

# OSP Triannual Period Status Comparison (April 2024 – July 2024)

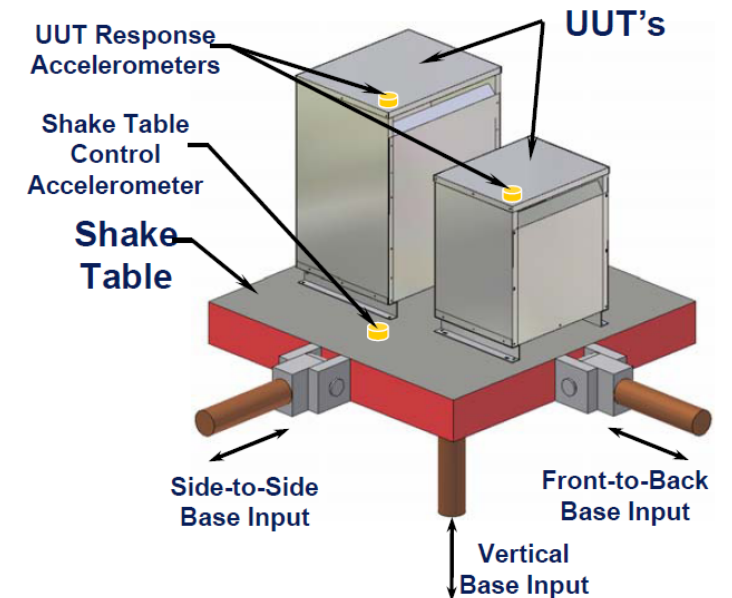
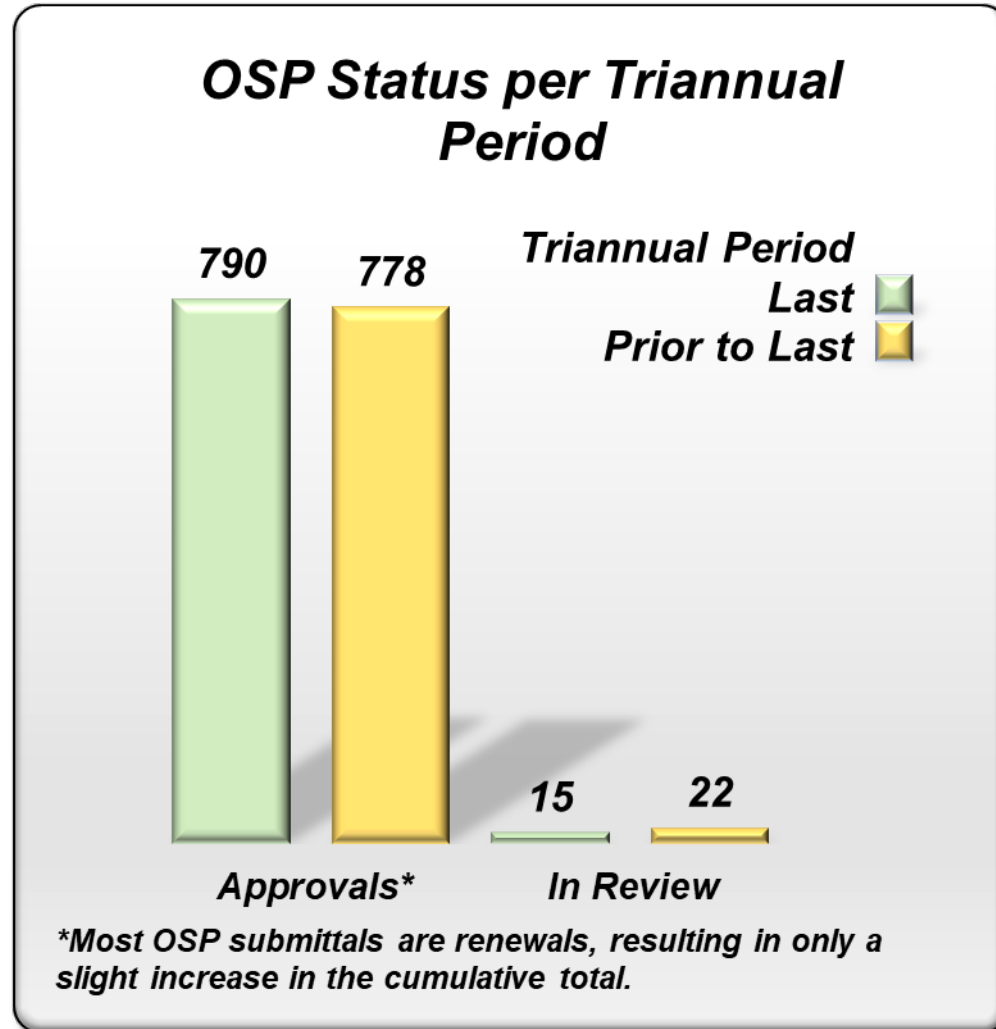

# OSP Triannual Period Workload

## Total HCAI OSP Activity Over Last Triannual Period

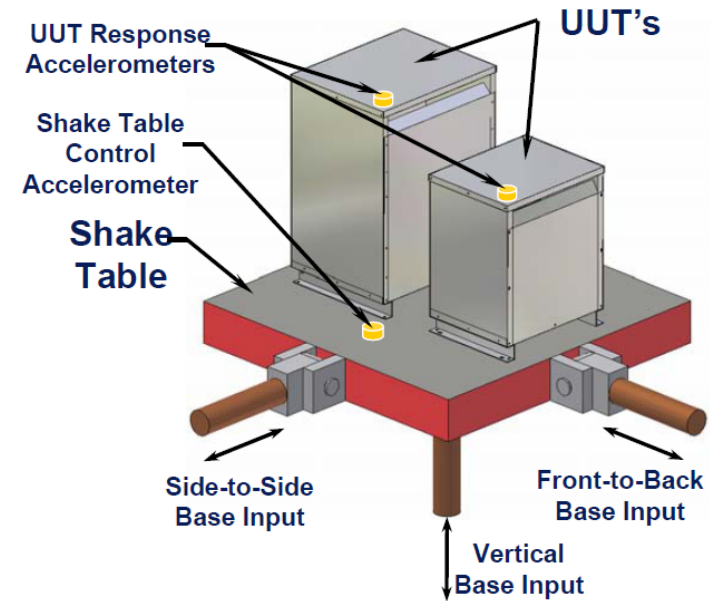
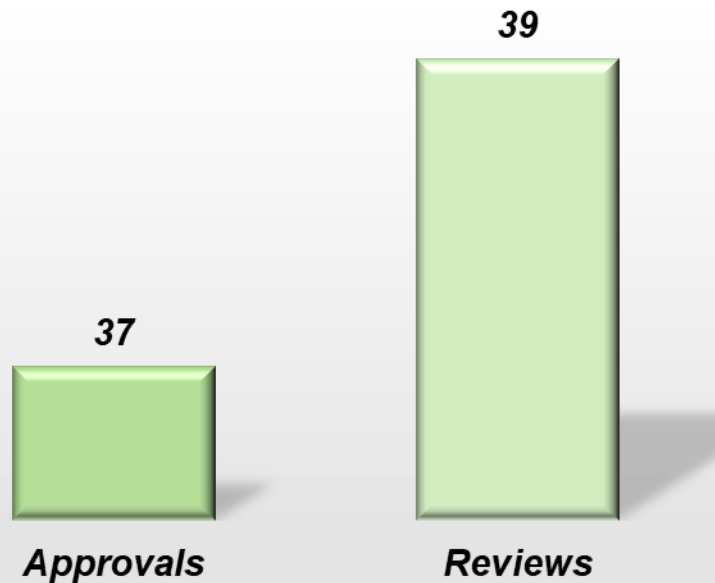

## OSP Workload over Triannual Period



# OPM Status – eSP Submittals Only

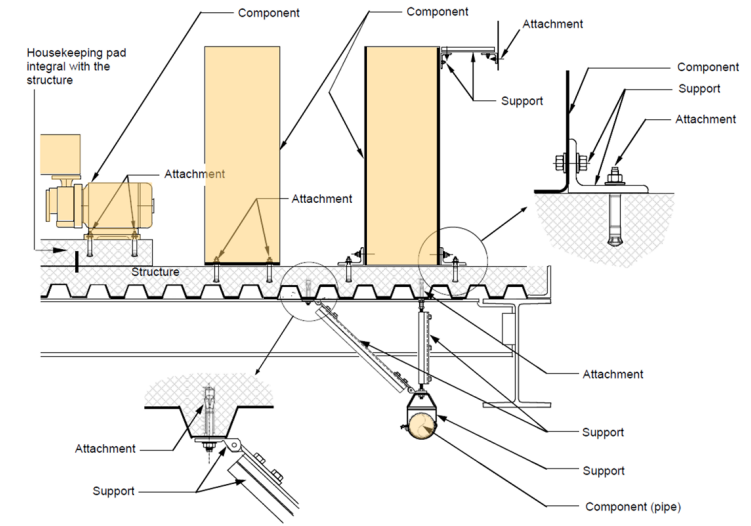
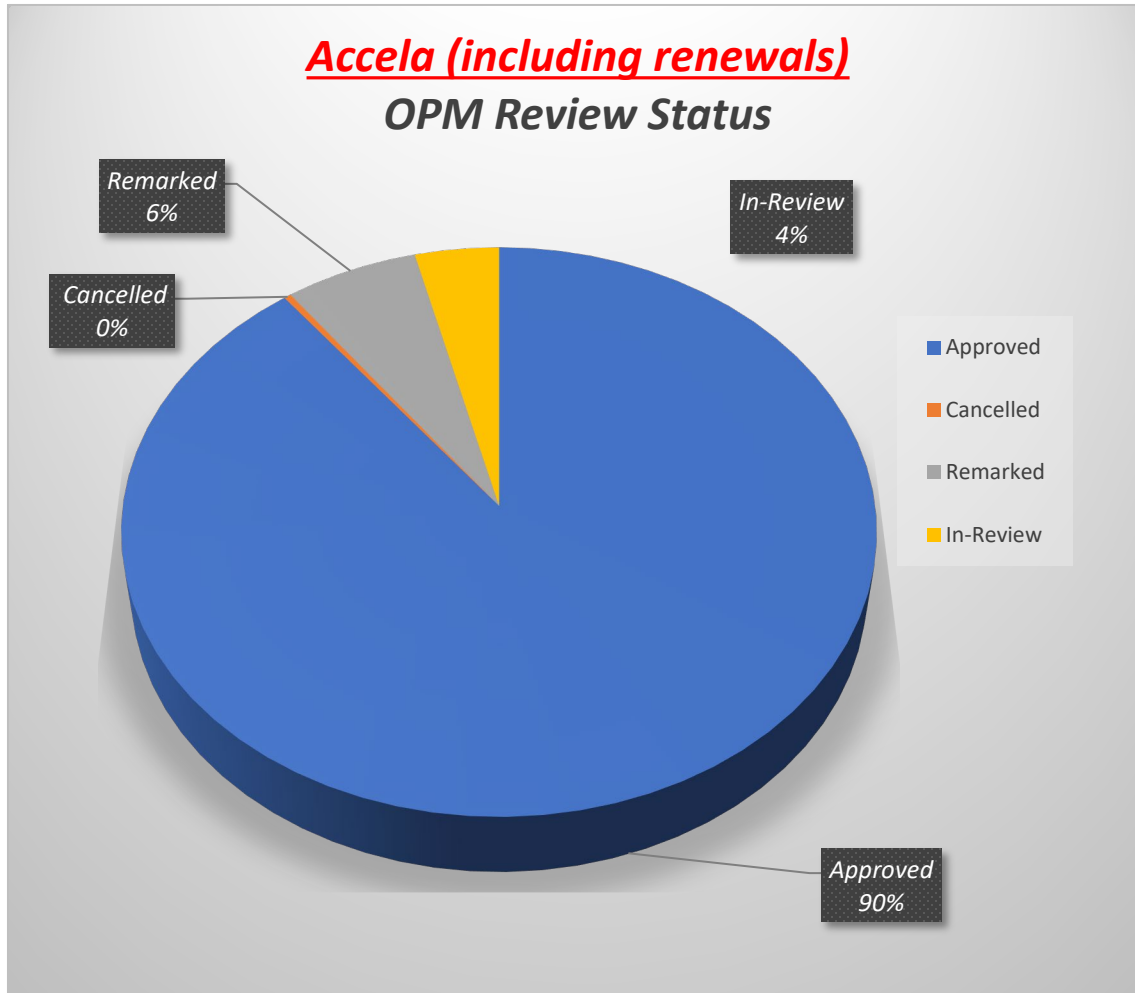

Aug 2024

TOTAL	305
Approved	273
Cancelled	1
Remarked	19
In-Review	12

Apr 2024

TOTAL	289
Approved	262
Cancelled	1
Remarked	16
In-Review	8

# OPM Status – eServices Portal (eSP)

**Accela (including renewals)**

**OPM Review Status**

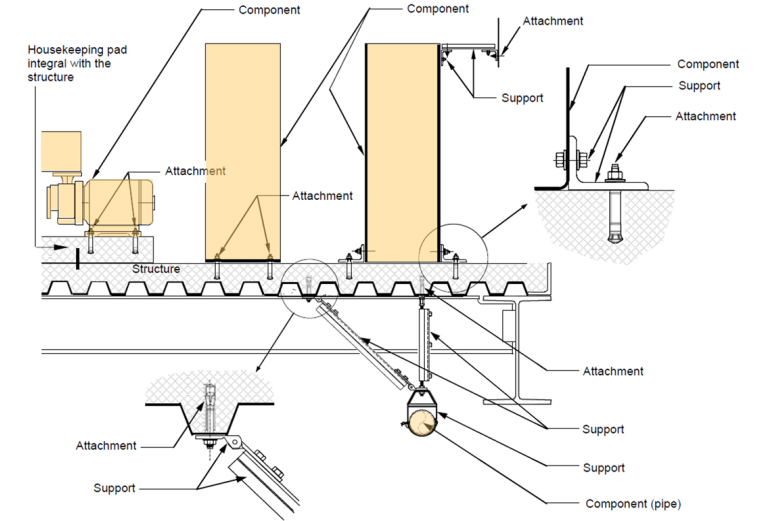
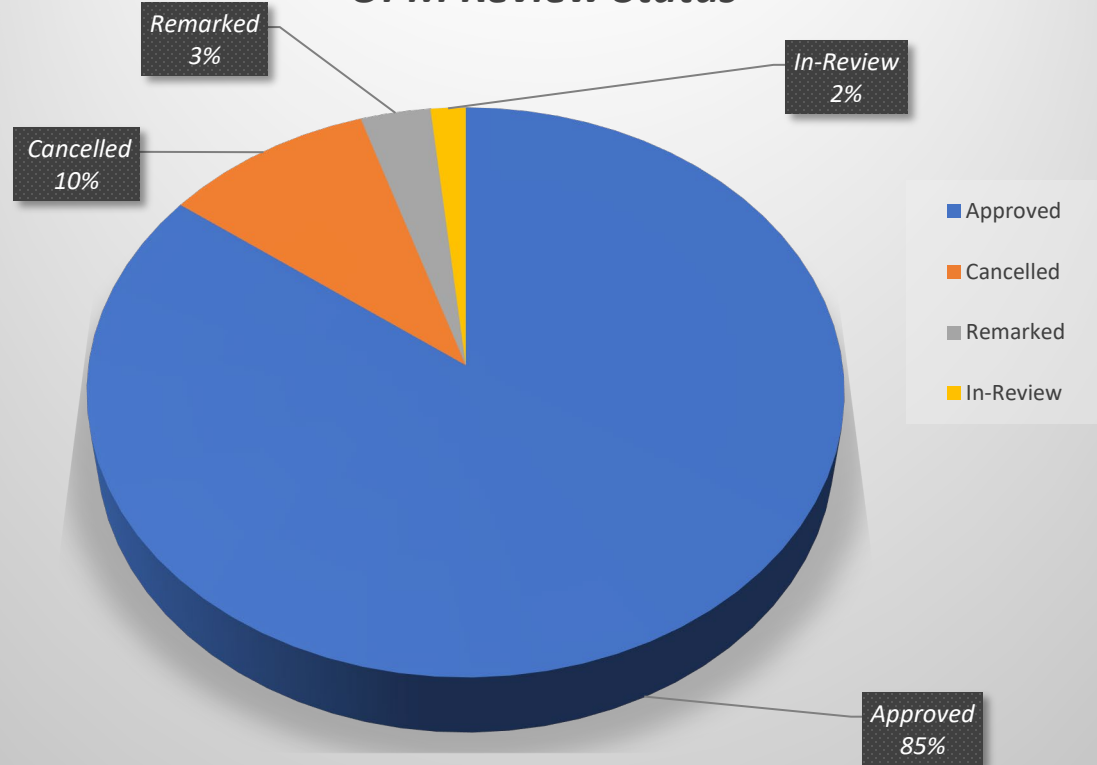

Aug 2024 (running total from day one)

<b>TOTAL</b>	<b>732</b>
Approved	624
Cancelled	72
Remarked	24
In-Review	12

April 2024 (running total from day one)

<b>TOTAL</b>	<b>717</b>
Approved	606
Cancelled	72
Remarked	22
In-Review	17

# New Force Equation ASCE 7-22 – Nonstructural Components

- **ASCE 7-16**

$$\frac{F_p}{W_p} = (0.4S_{DS}) \times \left[ 1 + 2 \left( \frac{z}{h} \right) \right] \times \left[ \frac{a_p}{R_p} \right] \times I_p$$

- **ASCE 7-22**

$$\frac{F_p}{W_p} = (0.4S_{DS}) \times \left[ \left( \frac{H_f}{R_\mu} \right) \right] \times \left[ \frac{C_{AR}}{R_{p0}} \right] \times I_p$$

- **New equation dependent on**

- Building type
- Building period
- Component ductility/resonance
- Component strength reserve margin
- Peak floor acceleration/Peak ground acceleration

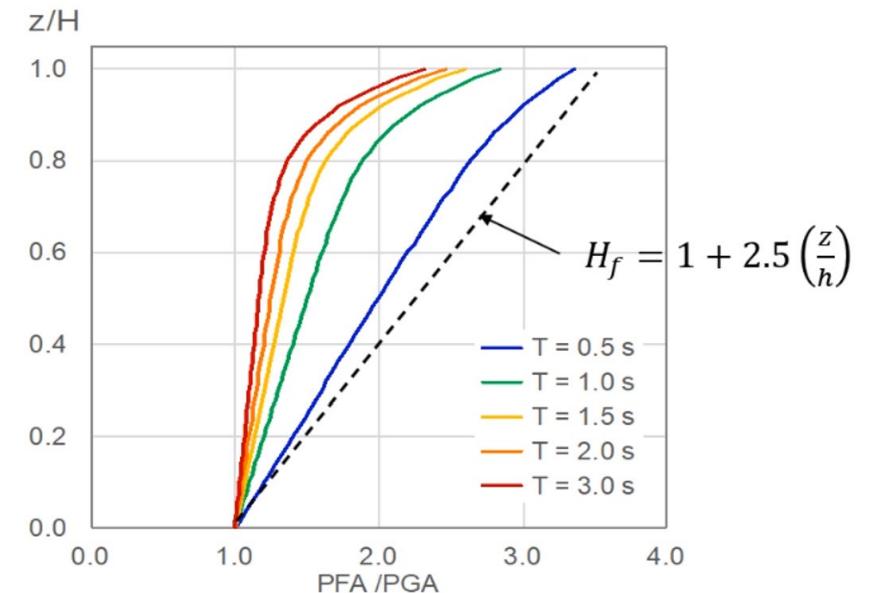

# Changes to ASCE 7-22 Affecting OSHPD Preapproval Programs

ASCE 7-22 Chapter 13 Nonstructural Components code changes comprise the most significant revisions in a quarter century.

## Affected OSHPD Preapproval Programs:

OPD-0001 Standard Partition Wall Details

OPD-0002 Standard Suspended Ceiling Details

OPD-0003 Standard Gypsum Board Ceiling Details

OPM – OSHPD Preapproval of Manufacturer's Certification

OSP – OSHPD Special Seismic Certification Preapproval

PCS – OSHPD Preapproved Prefabricated Components and Systems

Efforts to address changes are currently underway allowing for continued use of all existing submittals.

# Changes to ASCE 7-22 Affecting OSHPD Preapproval Programs

**Existing Preapprovals:** All existing preapprovals are readily applicable to any project by equating the preapproved force level demands to the proposed site demands. [Guidance to be noted within the associated OSHPD program PIN.](#)

**Renewal Preapprovals:** Renewals may have minor presentation revisions, without any additional calculations or shake table tests. Revised Application forms with revision requirements to be listed within the PINs, prior to Code acceptance.

**New Preapprovals:** New preapprovals will have revised Application forms depicting specific component classifications, with design force level demands and capacities.

# OPAA Review Status

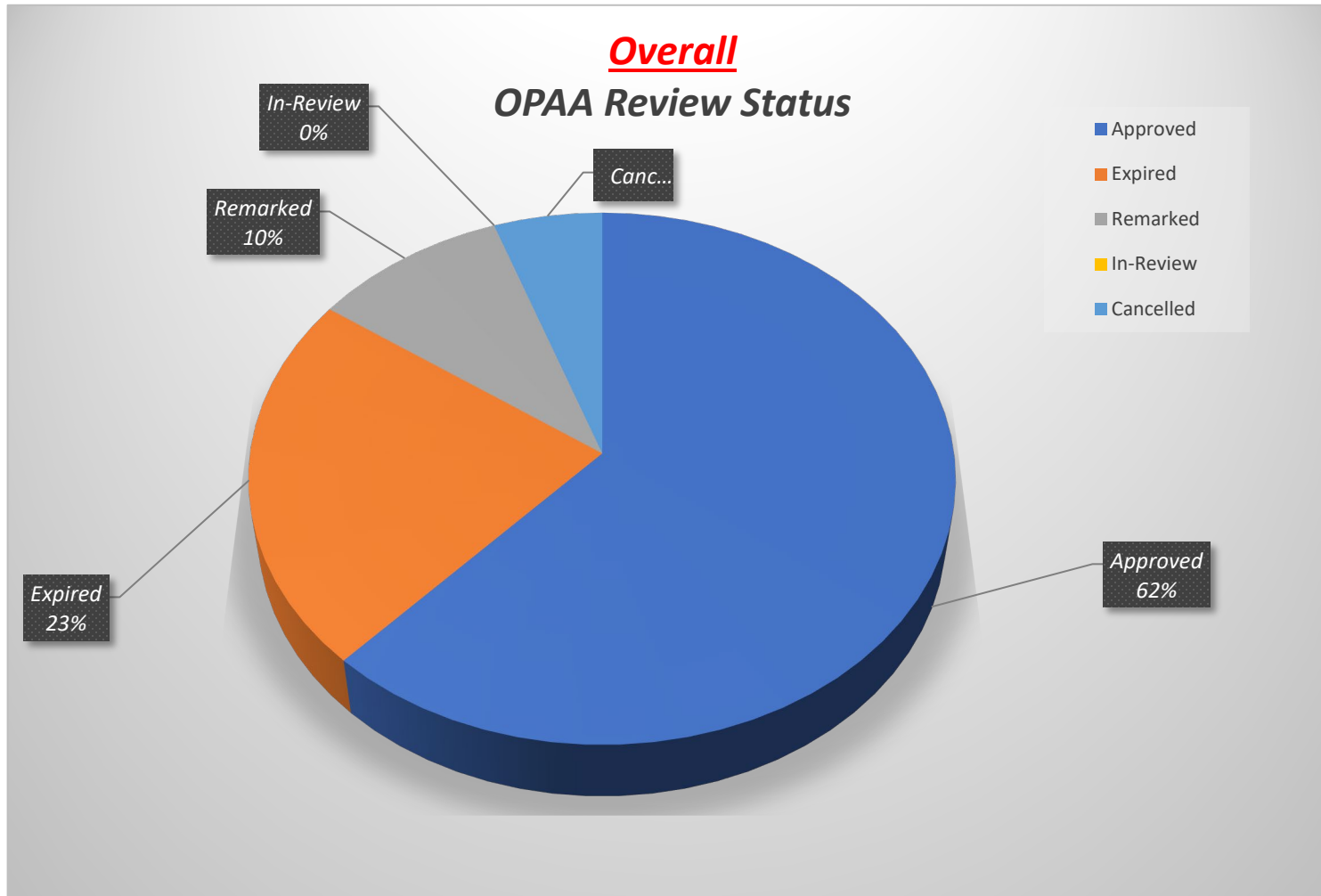

**August 2024**

OPAA Review Status

Total	92
Approved	57
Expired	21
Remarkd	9
In-Review	0
Cancelled	5

**April 2024**

OPAA Review Status

Total	91
Approved	67
Expired	16
Remarkd	3
In-Review	0
Cancelled	5



# Geotech Report Review Process

---

- ❑ Evaluating seismic hazard based on regional seismicity and faulting, ground motion studies specific to the site, assessment of hazards related to liquefaction (such as lateral spreading), landslides, floods, and more.
- ❑ Permanent/temporary shoring designs, piles and micropiles, soil nails, foundation design, soil improvements techniques, and other geotechnical issues

The review process for Geotech reports takes about four weeks to complete.

# Geotech Report Review Progress (August 2024)

Geotech Reports Review Process (2022 - 2024 Projects)

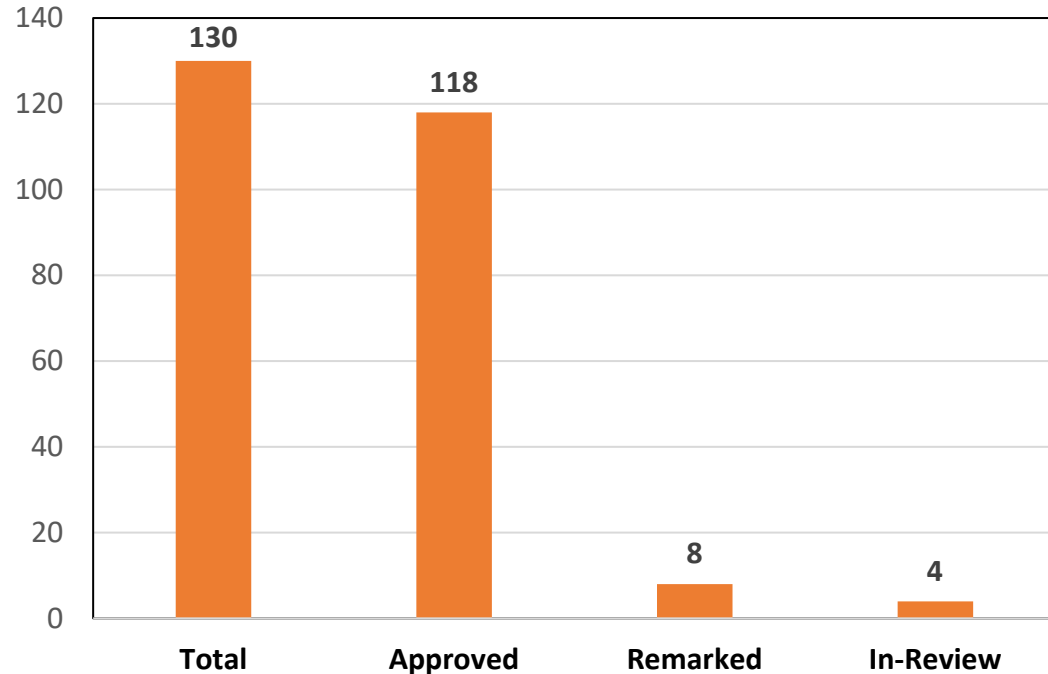

Construction Type (2022 - 2024 Projects)

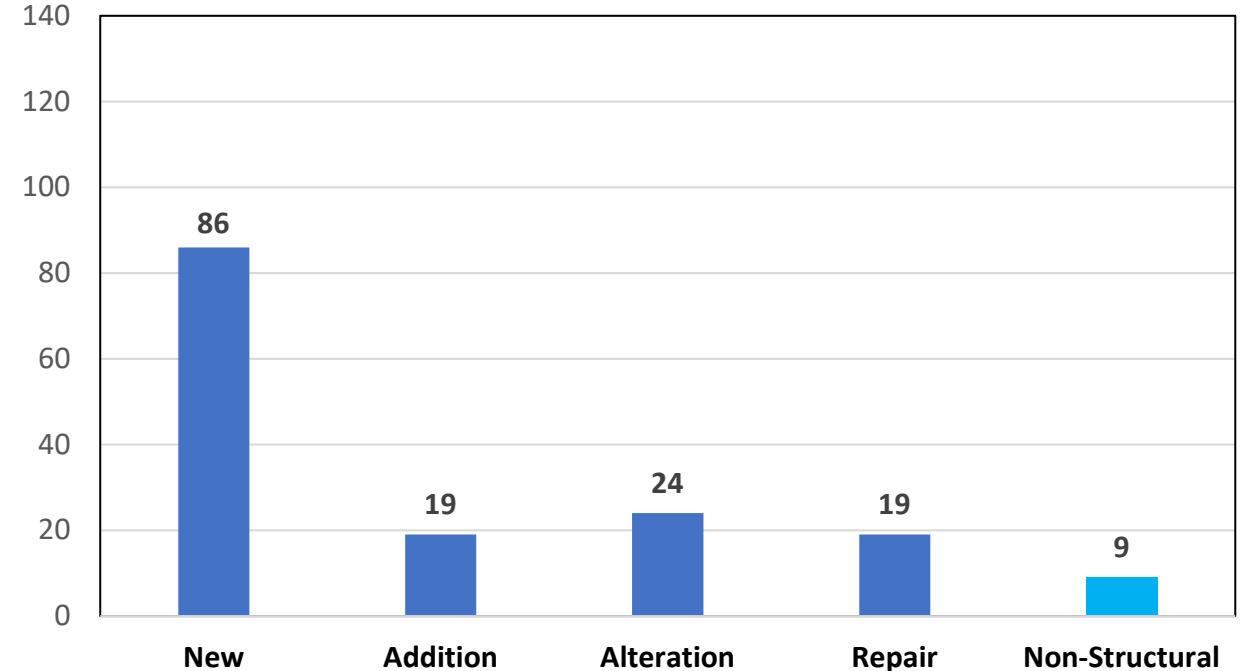

On average, there is a submission of one new or revised geotechnical report per week.

# Seismic Instrumentation of Hospitals

Hospital buildings are often situated near active faults and are in areas with high or very high seismic risk.

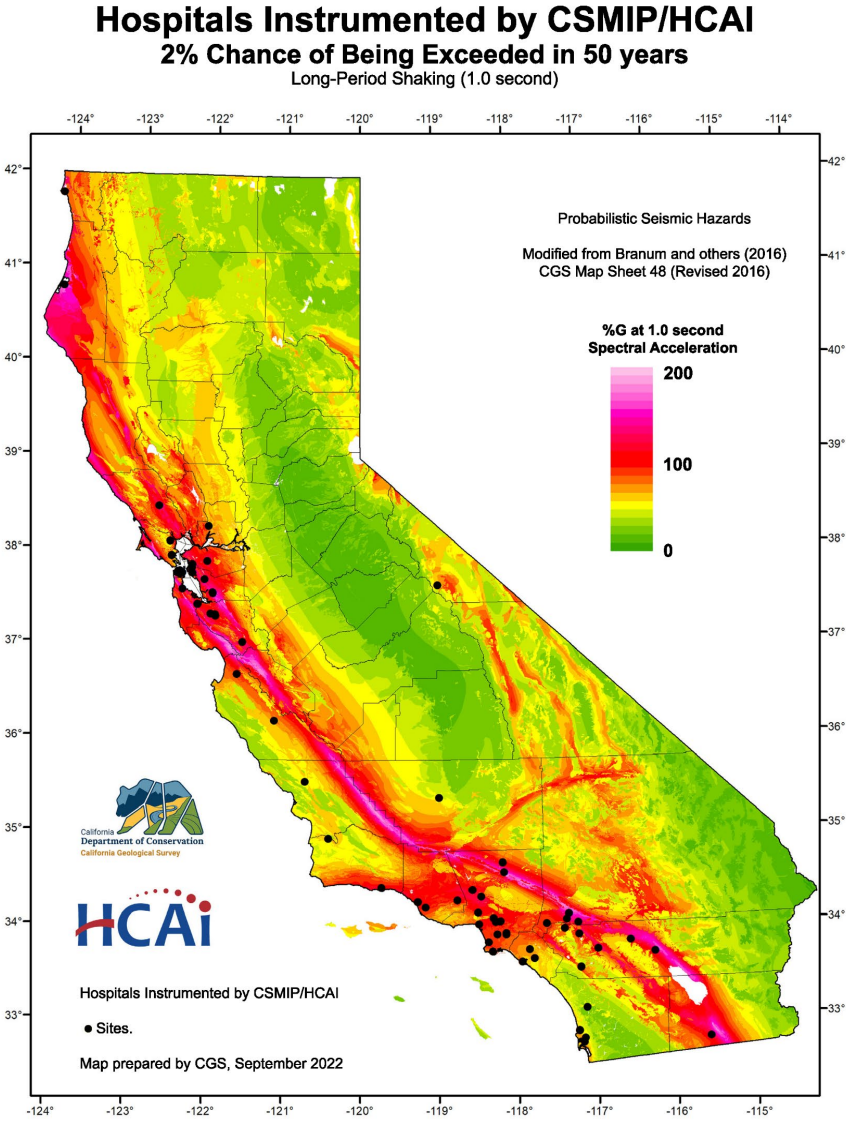
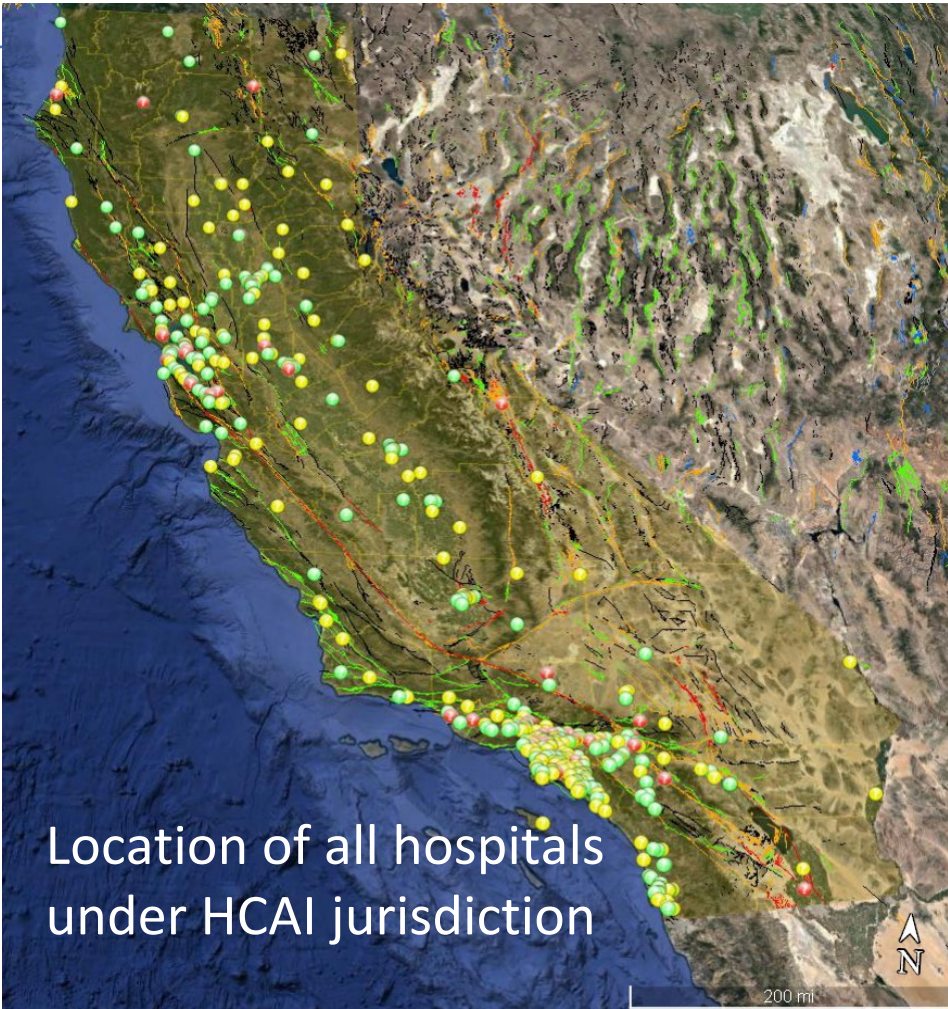

HCAI collaborated with CGS/CSMIP to install instruments in 85 hospitals.



# Seismic Instrumentation Progress

Instrumentation Projects (FY20-26)

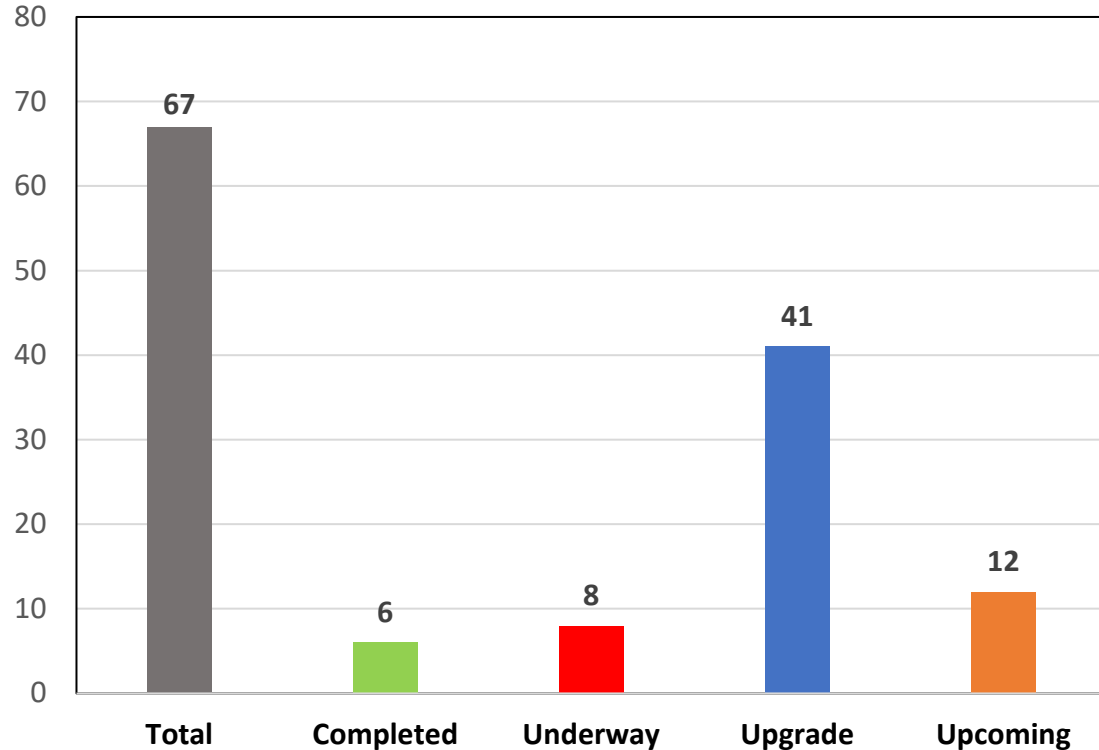

Instrumentation Projects (FY20-26)

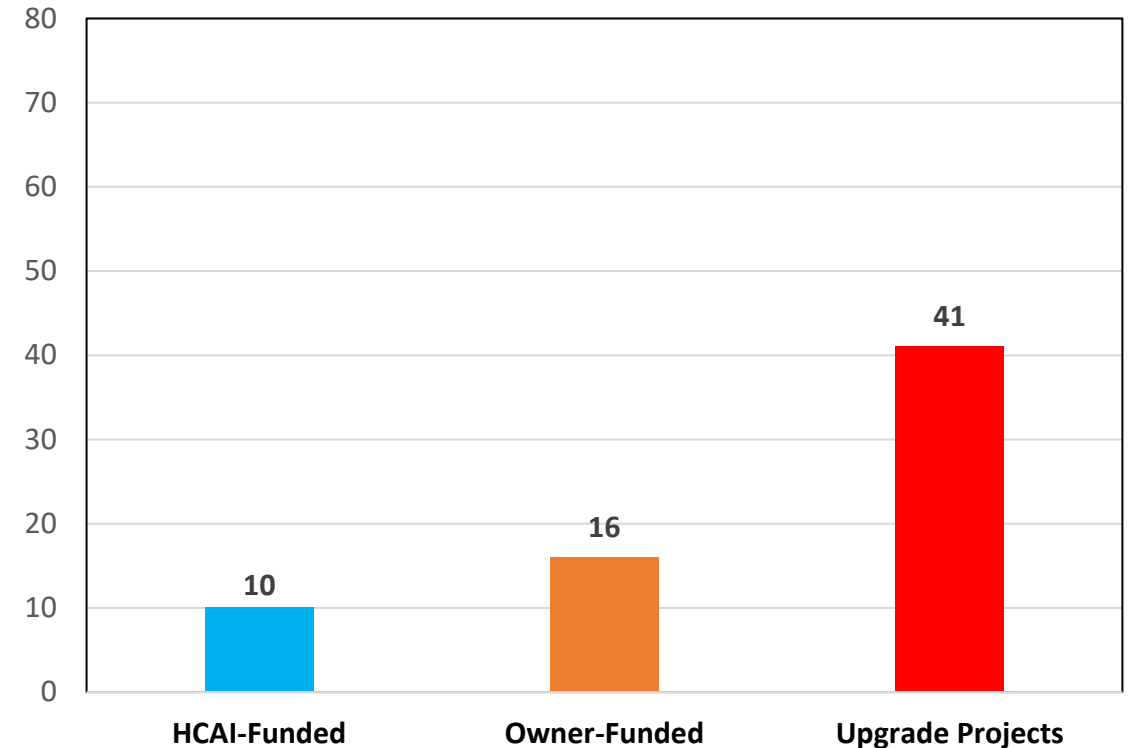

Most of the instrument projects were financed by the hospital owners.



# Instrumentation of Wood-Frame Hospital Buildings



- Predominantly single-story facilities
- Built era varies from 1902 to 2023
- There are only two instrumented wood-frame hospital buildings:
  - John F. Kennedy Memorial Hospital (Indio), and
  - Tenet Health Central Coast Twin Cities Community Hospital (Templeton)

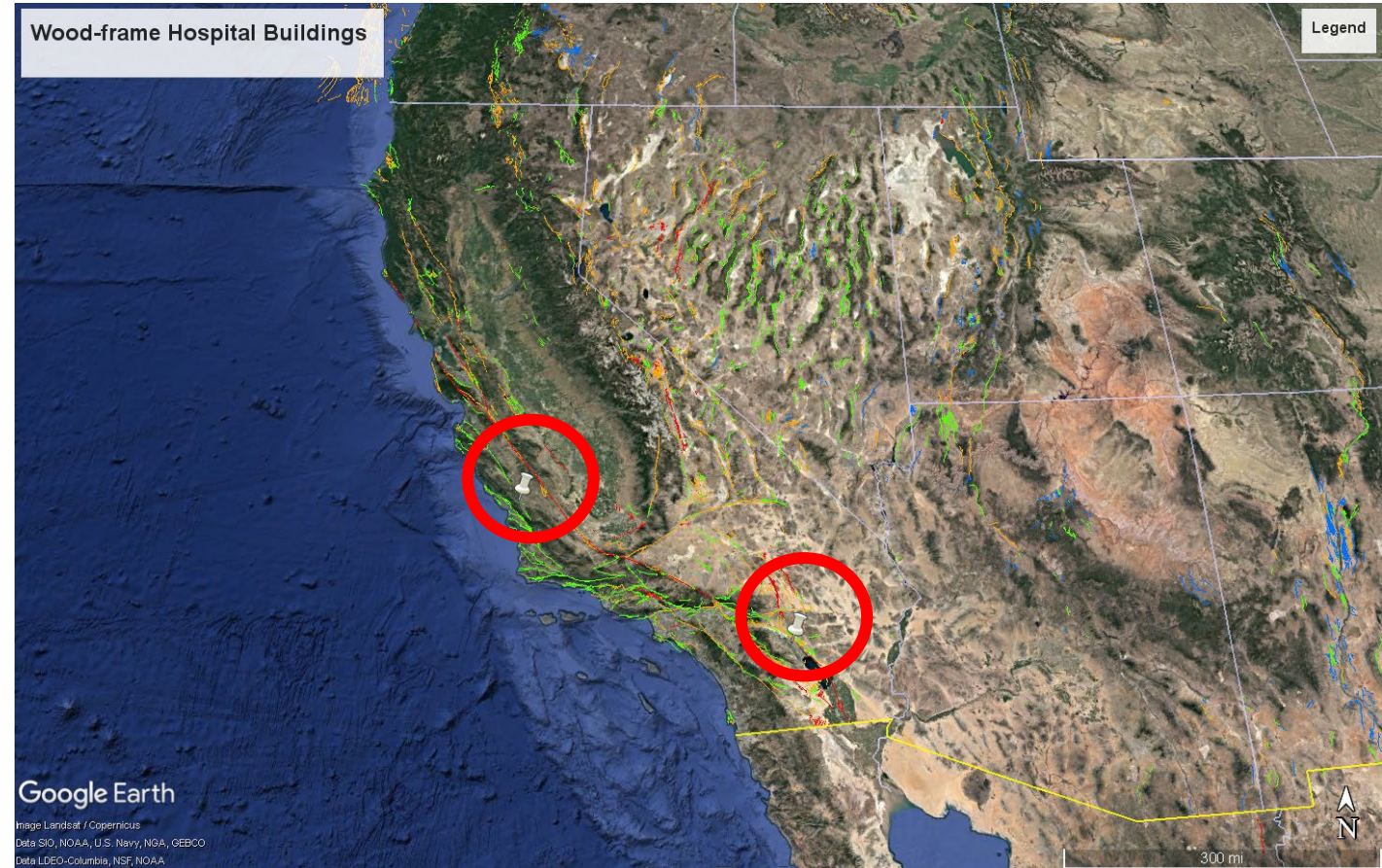



# Candidate Wood-Framed Buildings

- Per recommendation of the HBSB Instrumentation Committee in January 2024 meeting, seven buildings are identified for seismic instrumentation (to be funded by HCAI).

Providence Redwood Memorial Hospital	Fortuna	BLD-00529	1955	Original Hospital Building	02 - Wood, Commercial, Industrial	2.12
Healdsburg Hospital	Healdsburg	BLD-00919	1972	Main Hospital Building	01 - Wood, Light Frame	2.242
Providence Santa Rosa Memorial Hospital	Santa Rosa	BLD-01529	1961	Original Hospital Building	01 - Wood, Light Frame	2.364
Hazel Hawkins Memorial Hospital	Hollister	BLD-01458	1960	Original Hospital Building	02 - Wood, Commercial, Industrial	2.295
Community Memorial Hospital - Ojai	Ojai	BLD-00606	1960	Hospital Building	01 - Wood, Light Frame	1.873
Monterey Park Hospital	Monterey Park	BLD-00946	1971	Original Hospital Building	01 - Wood, Light Frame	1.948
Community Hospital of San Bernardino	San Bernardino	BLD-01851	1969	Wings 700/800/900	01 - Wood, Light Frame	2.294

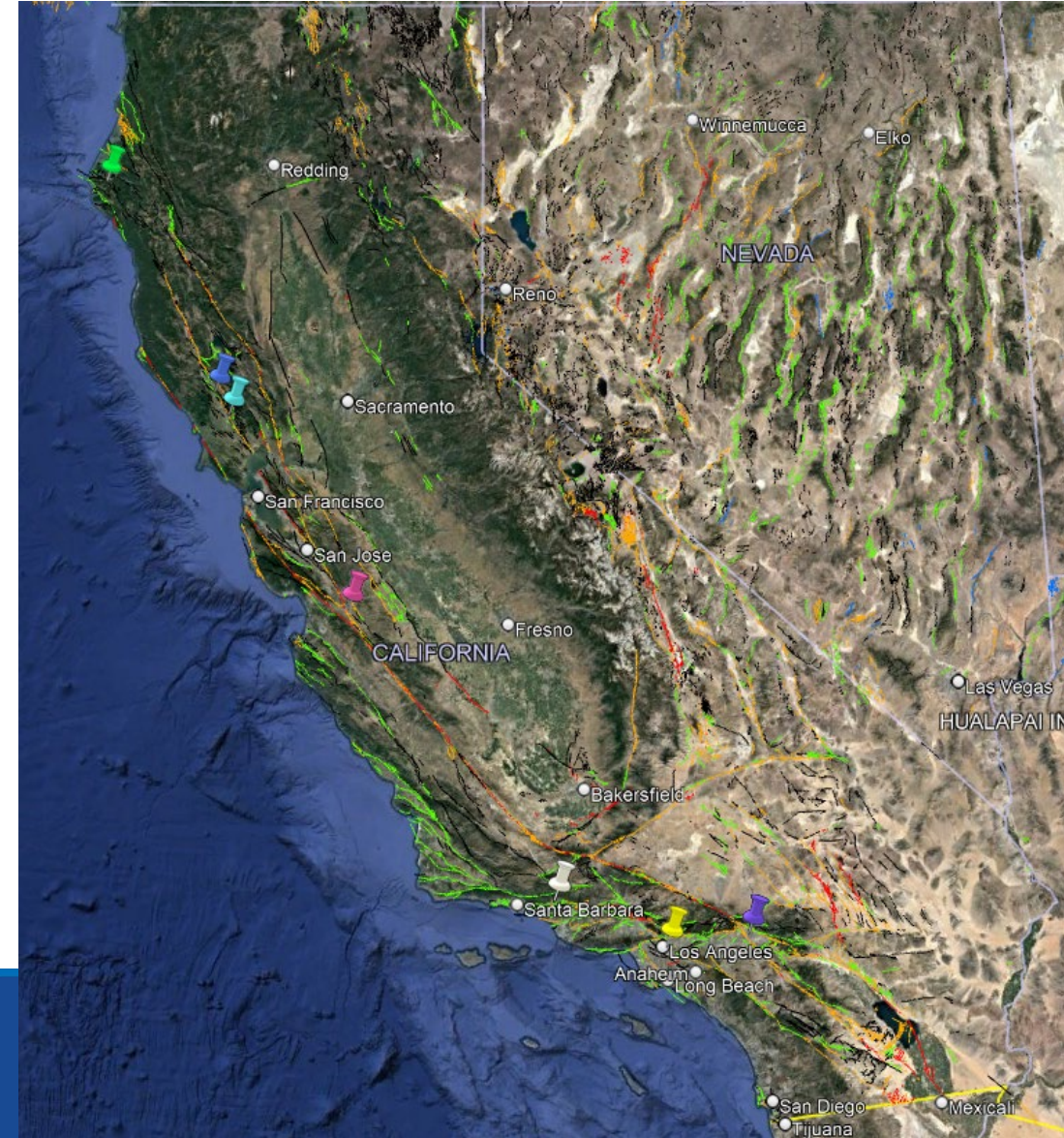



# Proposed Instrumentation Layout



Providence Santa Rosa Memorial Hospital Facility No. 11054 05/11/21

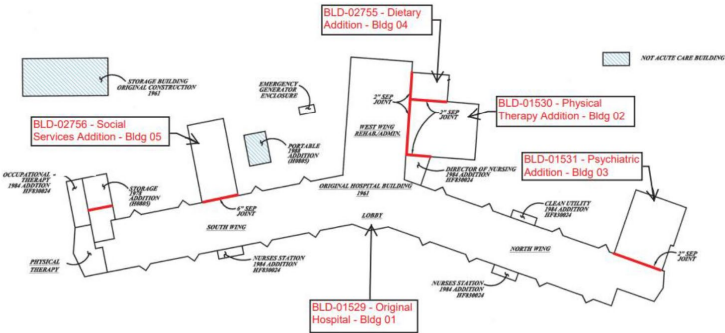

## Ground Floor Ceiling Mount

**Instrumentation Summary**

**Sensor list:**

- Triaxial x 1
- Biaxial x 5
- Uniaxial x 3
- MEMS x 1

**# of recorder channels: 16**

**# of locations: 9 + 1**

Note: Interior and exterior shear walls are invisible at architectural and structural drawings

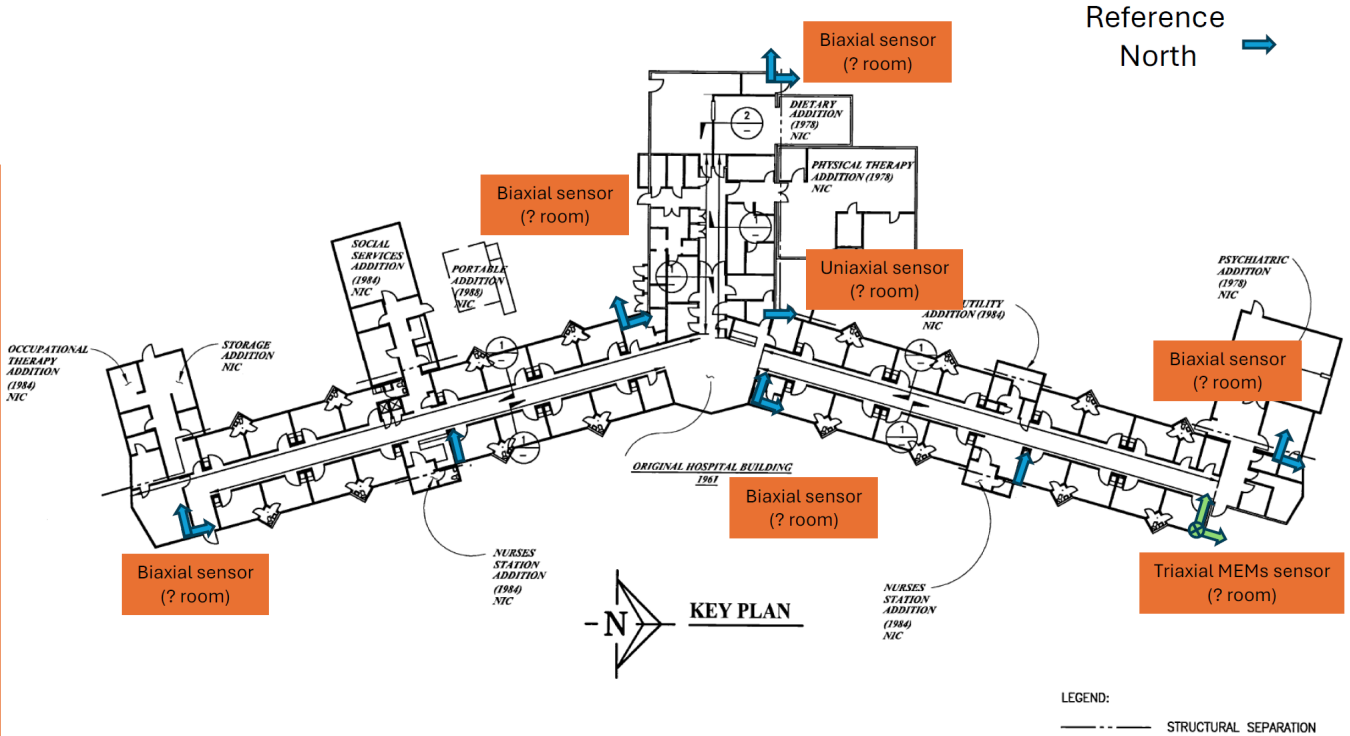

# 2025 California Building Code, Title 24

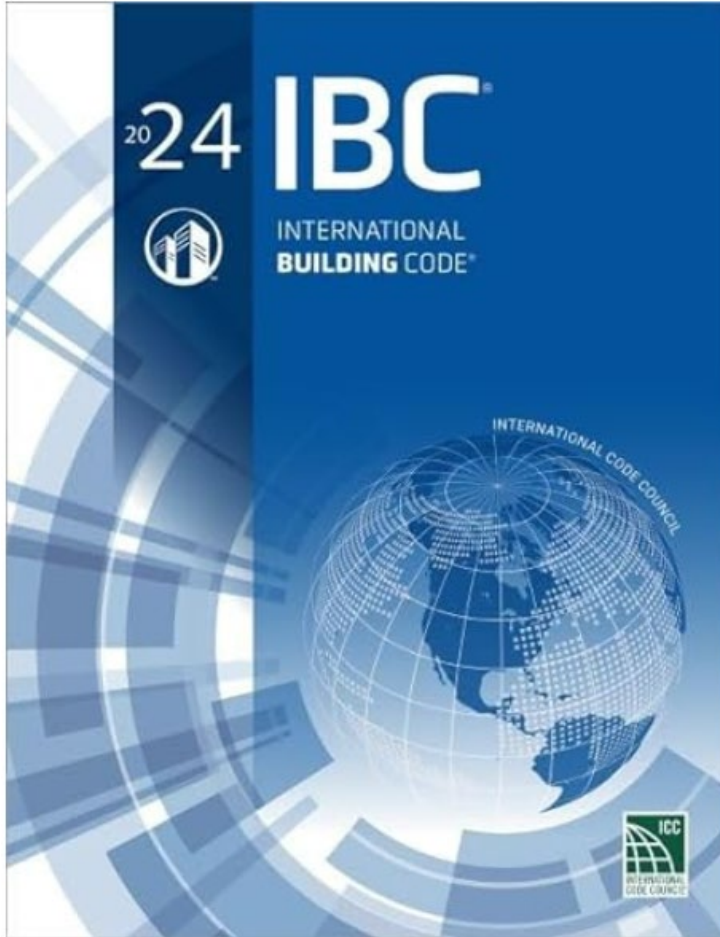

Code amendment package has been heard by the Code Advisory Committee

No major comments or revisions suggested

Additional changes were made in coordination with DSA for alignment with their code amendments. Revisions were mostly editorial in nature, with minor substantial changes

Submitted to the Building Standard's Commission for 45-Day comment review

# 2025 California Existing Building Code, Title 24

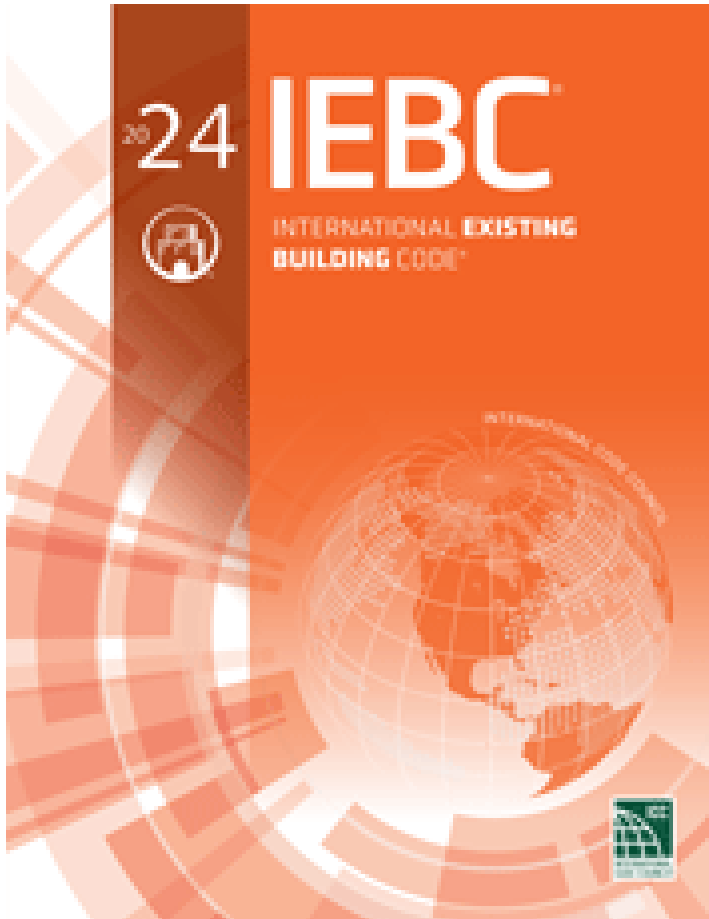

Code amendment package has been heard by the Code Advisory Committee

Minor editorial changes made from our initial submittal

Submitted to the Building Standard's Commission for 45-Day comment review

# Other Activities

- Participation in national codes and standards committees
  - BSSC
    - 2026 NEHRP (PUC)
    - IT-1 & IT-4
    - Functional Recovery Task Committee (FRTC)
  - ASCE 7-28
    - Main Committee
    - Seismic subcommittee
    - Future conditions subcommittee
- Research and Development
- Presentations to Stakeholders

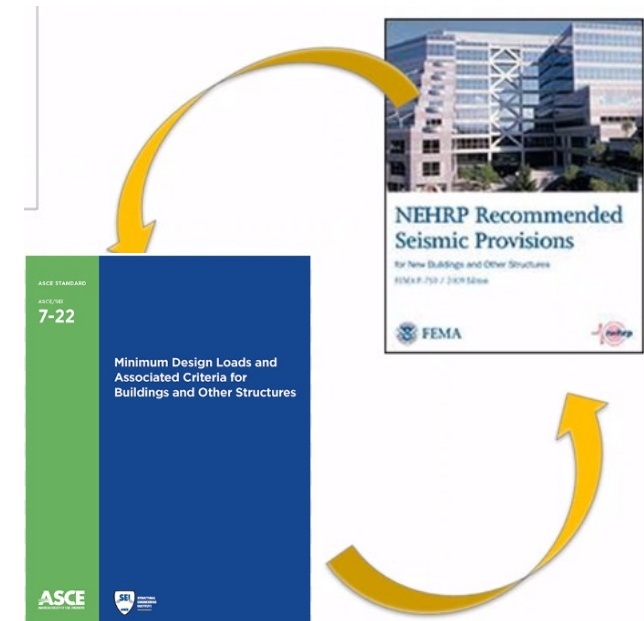

# Presentations to Industry and Stakeholders

- Presentations to SEAOC Seismology Committee - “Evaluation of Structures in High Seismic Regions - FEMA P-2343 An Introduction”
- Presentation to BSSC PUC – IT-4 – “Revise the value of  $I_e$  factor for RC IV structures”
- Presentation to BSSC PUC – IT-1 – “When Soil Flexibility must be included in the Analytical Model”

# What's Coming?

- **Steel PIN** to substitute existing Table 1705A.2 which is being repealed
- **PIN** for **NPC** compliance for anchorage and bracing of distribution systems
- **PIN 62** and **PIN 55** are being updated because of changes in ASCE 7-22 force demands for design of nonstructural components





## Item #12

### Inspection Services Unit (ISU) Update

- Update on ISU accomplishments year-to-date
- Update on HCAI ISU Construction Administration Proficiency (CAP) Training
- Update on electronic Test, Inspection, and Observation (eTIO)
- Discussion and public input

*Facilitators: Joe LaBrie, SE, Regional Compliance Officer, HCAI; Monica Colosi, Compliance Officer, HCAI; Darren Graves, Compliance Officer, HCAI; and Chris Davis, District Structural Engineer, HCAI (or designees)*



# Breaking Ground on

# Ground Breaking Change

August 15, 2024



# Inspection Services Unit

# Inspection Services Unit (ISU)

## ISU North



Colosi, Monica@HCAI

Compliance Officer, Health Facilities Con...



Lachica, Michelle@HCAI

Associate Governmental Program Analyst



Davis, Chris@HCAI

District Structural Engineer



Tran, Hoa@HCAI

Compliance Officer, Health Facilities Con...



Rodgers, Patrick@HCAI

Senior Structural Engineer



Yee-Oyoung, Janice@HCAI

Compliance Officer, Health Facilities Con...



LaBrie, Joe@OSHPD

Compliance Officer, Health Facilities Con...



## ISU South



Pan, James@HCAI

District Structural Engineer



Rucobo, Suzy@HCAI

Associate Governmental Program Analyst



Harrison, Jason@HCAI

Compliance Officer, Health Facilities Con...



Lyons, Bob@HCAI

District Structural Engineer



Schrenk, John@HCAI

Compliance Officer, Health Facilities Cons...



Graves, Darren@HCAI

Compliance Officer, Health Facilities Con...



# Hospital Inspector Certification Exam (HICE)



April 2024

## HOSPITAL INSPECTOR CERTIFICATION EXAMS

52 participants	LOS ANGELES - 33			SACRAMENTO - 19		
	Class A	Class B	Class C	Class A	Class B	Class C
Participants	27	5	1	13	6	0
Section Retests	9	2	0	4	1	0
Failed	18	3	0	8	4	0
Passed	9	2	1	5	2	0
Pass Rate	33%	40%	100%	38%	33%	N/A
Total Pass Rate:	36%			37%		
Statewide Pass Rate: 36%				Active IORs: 757		



# Hospital Inspector Recertification



March 2024

## INSPECTOR OF RECORD RECERTIFICATION

<b>115 participants</b>	<b>LOS ANGELES - 79</b>	<b>SACRAMENTO - 36</b>
Passed	79	36
Retests	5	5
Failed	0	0
Delinquent – Expired 3/31/24	11	10
Closed Inactive – Exp 9/30/23	6	5
Active IORs - Statewide	738	





# CO Academy

- A new program to improve training & consistency of service
- To begin September 4
- Value-Added: Greater efficiency

# ISU IOR Supplemental Monitoring

- Supplemental **IOR Performance Evaluations** completed by ISU members
- A new program to improve accountability for quality assurance
- Value-Added: Better inspection service

# IOR Utilization

- A new program to connect Inspector Supply with Demand
- Value-Added: Enhanced transparency

# Tip of the Day

- Reached 100 distributed Tips in July
- Spotlight consequential Field Issues
- Value-Added: Better real time clarity

# Field Brief Advice

- An improved program connecting to the Tip of the Day
- Live presentation and interaction to clarify Tips
- Value-Added: Clarifying conversations

# eTIO

- Value-Added: Process streamlining
- Chris Davis (ISU DSE) presentation

# ISU CAP Certification

- Value-Added: Knowledge increase
- Darren Graves & Monica Colosi (ISU CO) presentation



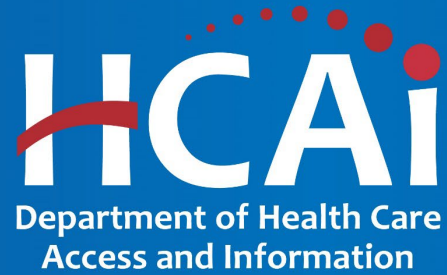

# **Construction Administration Proficiency (CAP) Results**

## ***August 15, 2024***

Inspection Services Unit



# Construction Administration Proficiency (CAP) Training

Part 1

June 6, 2024

741 Attendees

Part 2

July 11, 2024

562 Attendees

CAP Registered and Eligible  
254

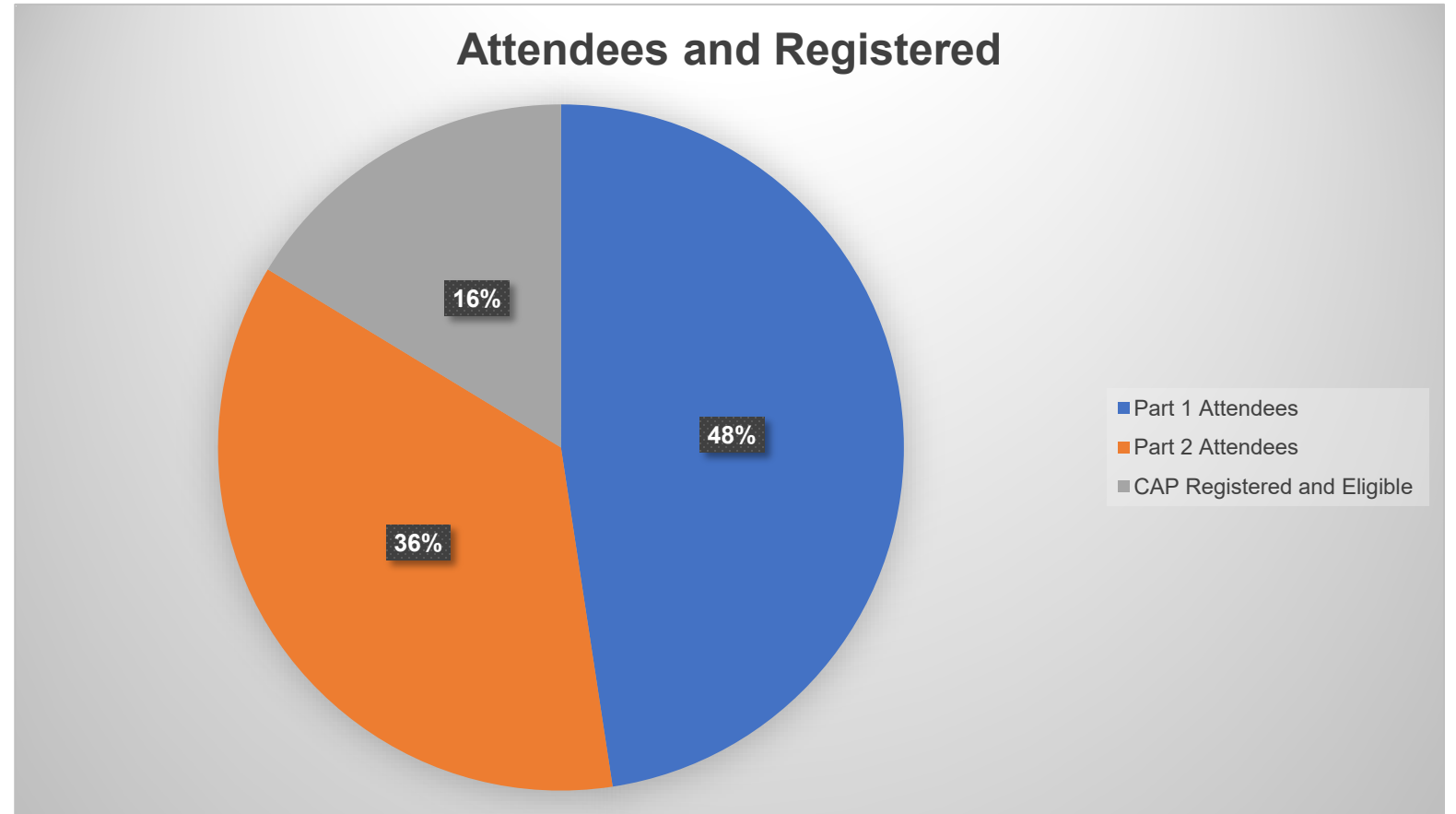



## Hospital Inspection Services and Certification

### General Inspection Information for Owners and Designers

Access lists of certified inspectors and guidelines for selecting an Inspector of Record (IOR)

[LEARN MORE](#)

### Hospital Inspector Certification Examination Information

See upcoming exam dates and access the exam application

[LEARN MORE](#)

### Recertification Information

Information for Inspector Recertification

[LEARN MORE](#)

### Construction Administration Proficiency Certified Exam

See the List of Successful CAP Certified Exam Candidates

[LEARN MORE](#)

## Voluntary Construction Administration Proficiency (CAP) Certified List

### List of Successful Exam Candidates

- o Omar Barcena
- o Tim Beemer
- o Zoe Bick
- o Craig Blackhurst
- o Keith Blazer
- o Stan Cheung
- o Thomas Coppin
- o Robert Crandall
- o Kayla Cunha
- o Jessica Files
- o Omar Galvan
- o Miguel Gonzalez
- o Jon Gray
- o Steven Harvey
- o Ryan Hayashida
- o Jonathan Heredia
- o Kimberly Huffman
- o Branden Ip
- o Scott Jensen
- o Matt Johnson
- o David Lin
- o Gladys Makabenta
- o Amanda Manning
- o Teresita Marquina
- o Anthony Martinez
- o Claudia Mendizabal
- o Paul Morgan
- o Nathan Morgan
- o Geny Munoz
- o George Narancic
- o Martin Ortega
- o Sam Ouyang
- o Charles Parks
- o Xiang Qin
- o Paul Reski
- o Russell Rocker
- o Marc Rudy
- o Tamara Sahagian
- o Kelly Schreihofner
- o Steven Sequoia
- o Suzanne Stahl
- o RJ Stanfield
- o Nathan Steele
- o Anupa Suguraman
- o Nathan Thompson
- o Mark C. J. Tu
- o Clarissa Urquico
- o Zhenyu Wang
- o Mikel Weaver
- o Tanner Williams
- o Bo Wongkalasin
- o Nathan Woods
- o Larry Yee



**HCAi Field TIP OF THE DAY**  
Subject: CAP Exam Result      Authored By: Monica Colosi  
HCAi ISU CO

**Construction Matters:**

The OSHPD voluntary Construction Administration Proficiency (CAP) exams were held on July 23rd in Los Angeles, and on July 24th in Sacramento. HCAi and the Inspection Services Unit (ISU) would like to congratulate the candidates that passed the exam.



**Today's Tip:**

Congratulations to:

Omar	Barcena	Scott	Jensen	Marc	Rudy
Tim	Beemer	Matt	Johnson	Tamara	Sahagian
Zoe	Bick	David	Lin	Kelly	Schreihofner
Craig	Blackhurst	Gladys	Makabenta	Steven	Sequoia
Keith	Blazer	Amanda	Manning	Suzanne	Stahl
Stan	Cheung	Teresita	Marquina	RJ	Stanfield
Thomas	Coppin	Anthony	Martinez	Nathan	Steele
Robert	Crandall	Claudia	Mendizabal	Anupa	Suguraman
Kayla	Cunha	Paul	Morgan	Nathan	Thompson
Jessica	Files	Nathan	Morgan	Mark C. J.	Tu
Omar	Galvan	Geny	Munoz	Clarissa	Urquico
Miguel	Gonzalez	George	Narancic	Zhenyu	Wang
Jon	Gray	Martin	Ortega	Mikel	Weaver
Steven	Harvey	Sam	Ouyang	Tanner	Williams
Ryan	Hayashida	Charles	Parks	Bo	Wongkalasin
Jonathan	Heredia	Xiang	Qin	Nathan	Woods
Kimberly	Huffman	Paul	Reski	Larry	Yee
Branden	Ip	Russell	Rocker		

**The Big Idea:**

The candidates that passed the voluntary CAP exam received their Certification, and their names are listed on [the HCAi website](#). ISU will continue the CAP training Part 1 webinar in November, Part 2 webinar in December, and the voluntary CAP exam in January. Stay tuned for the Tip of the Day with registration for Part 1 and Part 2 webinars.

Omar	Barcena	Scott	Jensen	Marc	Rudy
Tim	Beemer	Matt	Johnson	Tamara	Sahagian
Zoe	Bick	David	Lin	Kelly	Schreihofner
Craig	Blackhurst	Gladys	Makabenta	Steven	Sequoia
Keith	Blazer	Amanda	Manning	Suzanne	Stahl
Stan	Cheung	Teresita	Marquina	RJ	Stanfield
Thomas	Coppin	Anthony	Martinez	Nathan	Steele
Robert	Crandall	Claudia	Mendizabal	Anupa	Suguraman
Kayla	Cunha	Paul	Morgan	Nathan	Thompson
Jessica	Files	Nathan	Morgan	Mark C. J.	Tu
Omar	Galvan	Geny	Munoz	Clarissa	Urquico
Miguel	Gonzalez	George	Narancic	Zhenyu	Wang
Jon	Gray	Martin	Ortega	Mikel	Weaver
Steven	Harvey	Sam	Ouyang	Tanner	Williams
Ryan	Hayashida	Charles	Parks	Bo	Wongkalasin
Jonathan	Heredia	Xiang	Qin	Nathan	Woods
Kimberly	Huffman	Paul	Reski	Larry	Yee
Branden	Ip	Russell	Rocker		



# Los Angeles

Omar Barcena  
Keith Blazer  
Thomas Coppin  
Robert Crandall  
Jonathan Heredia  
Kimberly Huffman  
Gladys Makabenta  
Teresita Marquina  
Paul Morgan  
Martin Ortega  
Tamara Sahagian

Suzanne Stahl  
Anupa Suguraman  
Tim Beemer  
Branden Ip  
Marc Rudy  
Steven Sequoia  
Nathan Steele  
Mark C. J. Tu  
Mikel Weaver  
Nathan Woods



# Sacramento

Zoe Bick  
Stan Cheung  
Kayla Cunha  
Jessica Files  
Omar Galvan  
Miguel Gonzalez  
Jon Gray  
Steven Harvey  
Ryan Hayashida  
Scott Jensen  
Matt Johnson

David Lin  
Amanda Manning  
Anthony Martinez  
Claudia Mendizabal  
Nathan Morgan  
Geny Munoz  
George Narancic  
Sam Ouyang  
Charles Parks  
Xiang Qin

Russell Rocker  
Kelly Schreihofner  
RJ Stanfield  
Nathan Thompson  
Clarissa Urquico  
Zhenyu Wang  
Tanner Williams  
Bo Wongkalasin  
Larry Yee  
Craig Blackhurst  
Paul Reski



### Sacramento CAP exam Registered 115 Show up 62

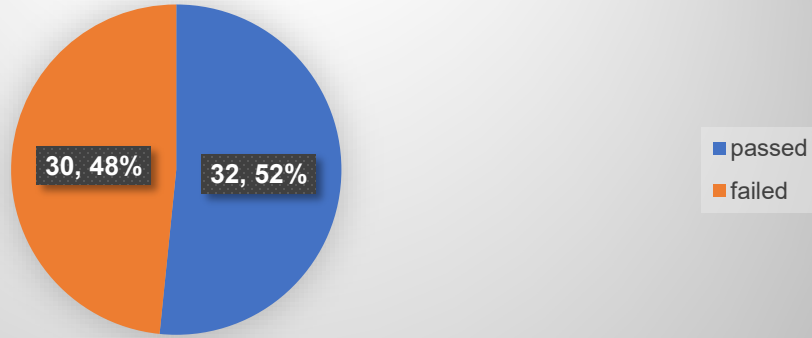

### Los Angeles CAP exam Registered 139 Show up 72

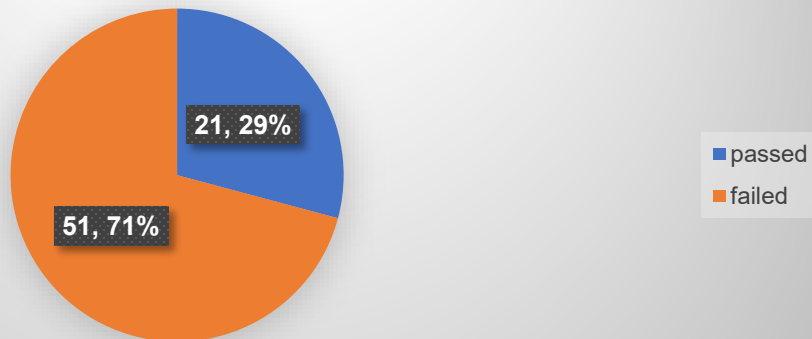

### Total CAP exam Registered 254 Show up 134

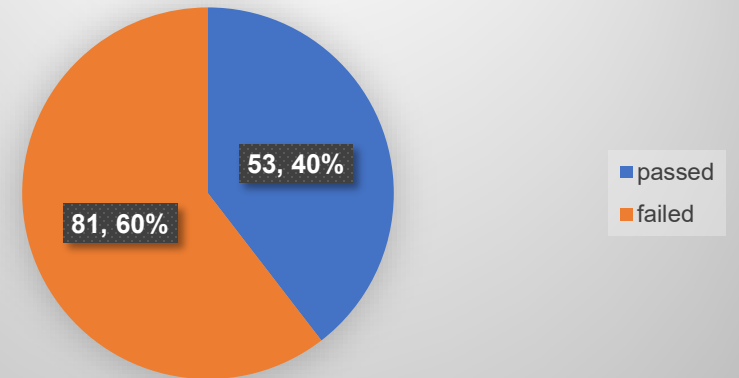



### Sacramento of the 32 passed

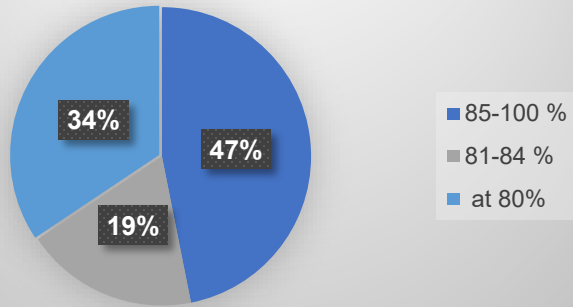

### Los Angeles of the 21 passed

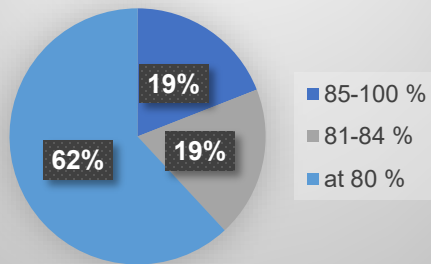

### Total of the 53 passed

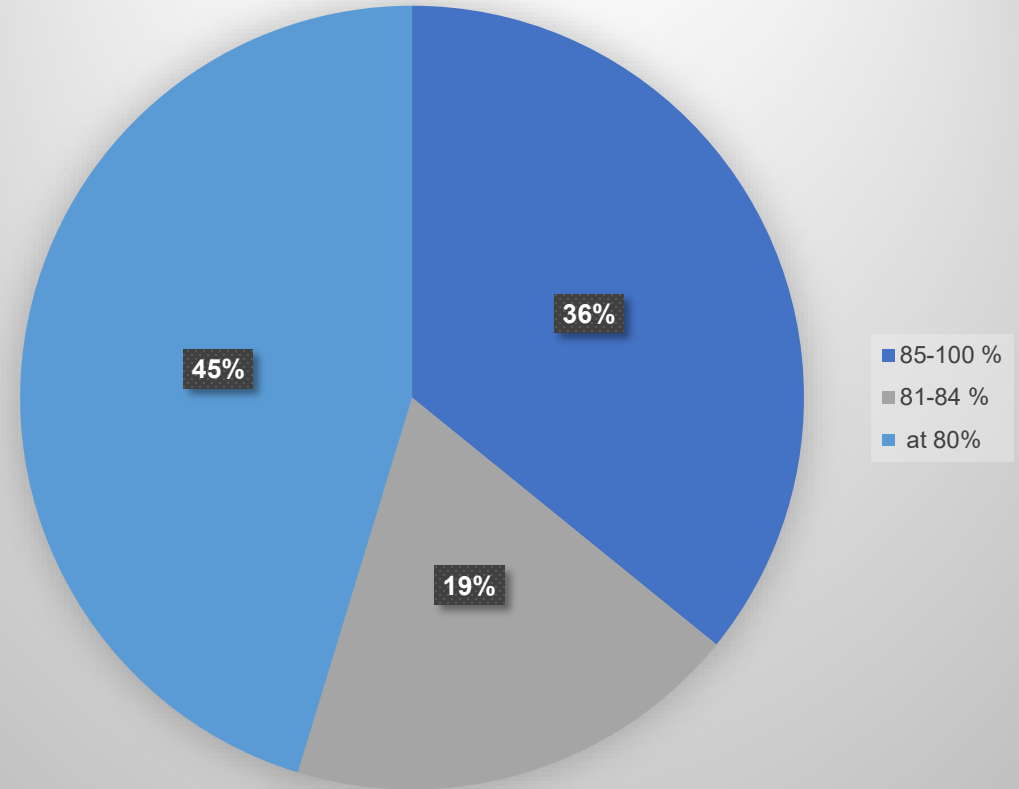

## CAP Certified Professions

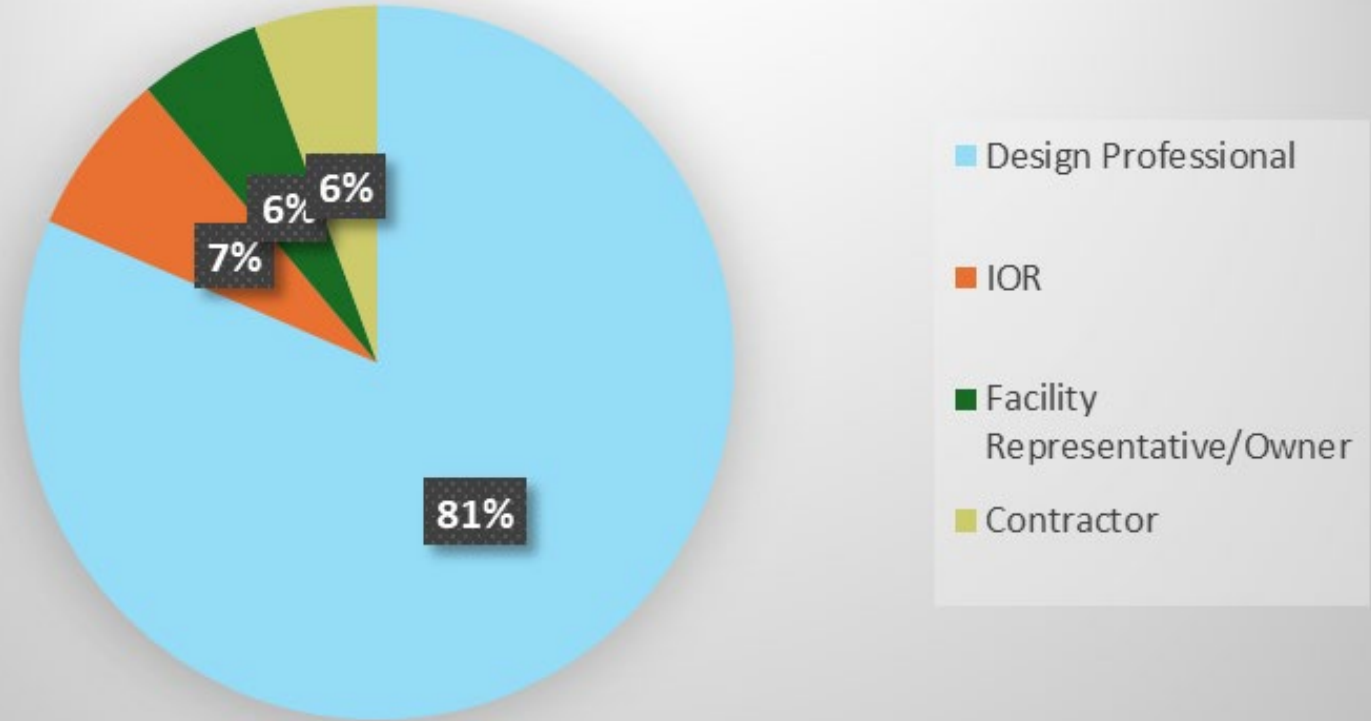

Part 1  
November 2024

Part 2  
December 2024

Voluntary CAP Exam  
January 2025

# What next?



**INSPECTION SERVICES UNIT**  
Office of Statewide Hospital Planning & Development

**HCAI Field TIP OF THE DAY**  
Subject: CAP Training and Certification      Authored By: Darren Graves  
HCAI ISU CO

**Construction Matters:**  
Often, the California Administrative Code, Part 1 is forgotten, not realizing this part of the code provides valuable information about any project: who has responsibility and what those responsibilities are for each individual involved on the project.



**Coming in October**

**Today's Tip:**  
Design Professional Of Record (DPOR) is responsible for the preparation of the construction project. DPOR responsibilities include:

HCAI Inspection Services Unit (ISU) provides a Voluntary Construction Administration Proficiency (CAP) Certificate after successful completion of our exam. Certification will be posted on the HCAI website.  
DPOR Responsibilities (Part 1) webinar, on 10/15/24: Registration [here](#)  
DPOR Responsibilities (Part 2) webinar, on 10/22/24: Registration [here](#)  
Webinars are prerequisite to the exam and HCAI will track the attendees. Additional Training Dates by Request and Exam Schedule TBD.

**The Big Idea:**  
HCAI ISU offers training in person and/or via Teams to individuals and to Companies upon request.  
The training and exam are offered not only to DPORs, but also to everyone who wants to better understand the California Administrative Code.  
Contact us at [isu@hcai.ca.gov](mailto:isu@hcai.ca.gov)  
Note: no license or certification is required to take the training and take the exam for the certification.



# Update on eTIO



Close Window

## Project Test and Special Inspections

Special Inspection List [Assign Default Responsible Entity to All Special Inspections](#)Filter by Scope:  Sub-Scope: 

ID	Item	Description	Assigned Default Responsible Entity
<a href="#">SI-A1</a>	Exterior insulation and finish systems (EIFS).	EIFS applications	OPAA-0001 Southwest Research Institute <a href="#">Assign/Edit</a> <a href="#">Remove</a>
<a href="#">SI-A2</a>	Water-Resistive Barrier Coating	ASTM E2570 barrier coating when installed over a sheathing substrate.	OPAA-0014 Terracon Consultants Inc <a href="#">Assign/Edit</a> <a href="#">Remove</a>

Showing 1 to 2 of 2 entries (filtered from 12 total entries)

Previous

1

Next

Test List [Assign Default Responsible Entity to All Tests](#)Filter by Scope:  Sub-Scope: 

ID	Item	Description	Assigned Default Responsible Entity
<a href="#">T-E1</a>	Ground Fault Protection of Equipment		OPAA-0001 Southwest Research Institute <a href="#">Assign/Edit</a> <a href="#">Remove</a>
<a href="#">T-E10</a>	Medium Voltage Outdoor Systems Testing		OPAA-0001 Southwest Research Institute <a href="#">Assign/Edit</a> <a href="#">Remove</a>
			OPAA-0001 Southwest Research Institute <a href="#">Assign/Edit</a> <a href="#">Remove</a>



Item #13

Fire Prevention Unit (ISU) Update

- Update on FPU accomplishments year-to-date
- Discussion and public input

*Facilitator: Nanci Timmins, Chief Fire and Life Safety Officer, HCAI  
(or designee)*

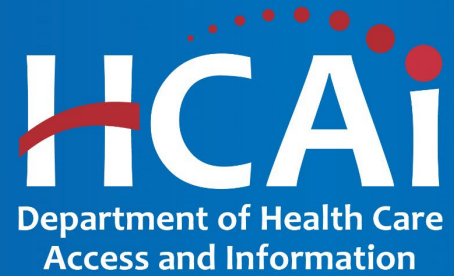

**HBSB**  
**Full Board Meeting**  
**Fire Prevention Unit Update**  
**August 2024**

Nanci Timmins  
Chief Fire and Life Safety Officer

# Fire Prevention Unit



**Bryan**



**Mike**

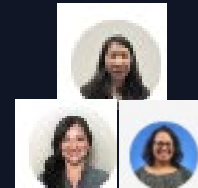

**Julia Assist**  
**Michelle 25%**  
**Suzy 25%**  
**Full time SSA remains**  
**vacant**



**Nanci**

**FPU Team**



# Fire Prevention Unit Update Topics

**FIRE LIFE SAFETY  
TRAINING PROGRAM**

**OTHER TRAINING**

**BUILDING STANDARDS**

**STAKEHOLDER TRAINING**

**COMMITTEES**

“Regular refresher training is essential to maintain proficiency and ensure the safety of both personnel and the public during fire emergencies.”

**NATIONAL FIRE PROTECTION ASSOCIATION (NFPA)**

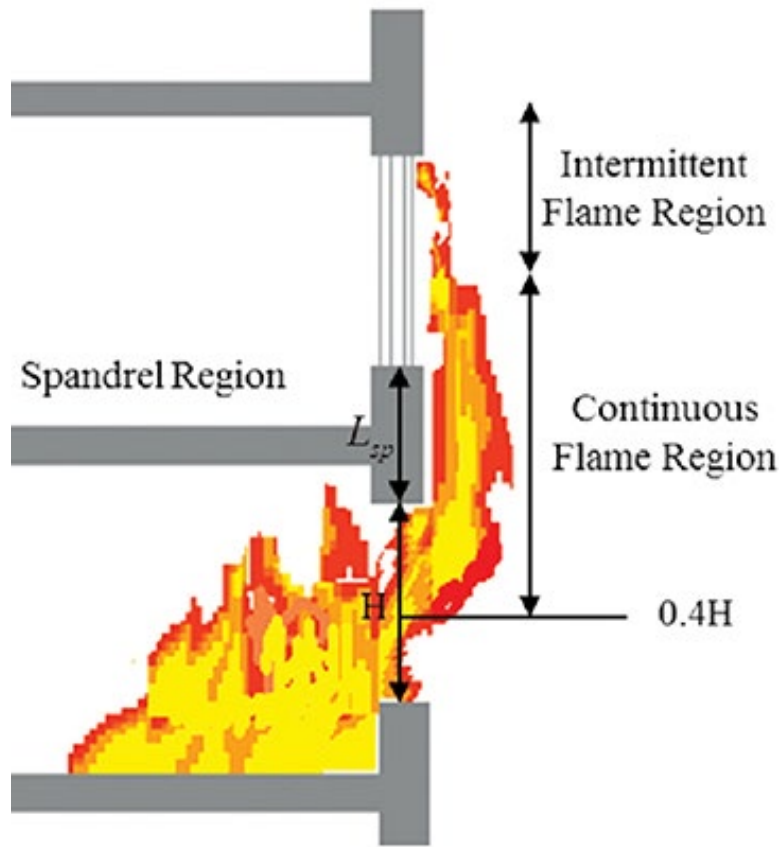

**THE FIRE PREVENTION UNIT HAS A COMPREHENSIVE FIRE LIFE SAFETY TRAINING PROGRAM TO ENHANCE FIRE SAFETY IN OUR FACILITIES FOR OUR COMMUNITY.**

Effective collaboration between fire safety experts, architects, design professionals and other stakeholders is crucial in enhancing fire safety during the building design and construction process. By working closely with all stakeholders, fire safety professionals provide valuable insights and recommendations to ensure that fire prevention and mitigation measures are seamlessly integrated into the architectural design, resulting in safer and more resilient structures, and to establish the minimum code requirements to safeguard the public health, safety and general welfare; safety to life and property from fire and other hazards attributed to the built environment; and to provide safety to fire fighters and emergency responders during emergency operations.



# Fire Prevention Unit Updates



**FIRE LIFE SAFETY TRAINING**



**BUILDING STANDARDS**



**STAKEHOLDER TRAINING**



**COMMITTEES**

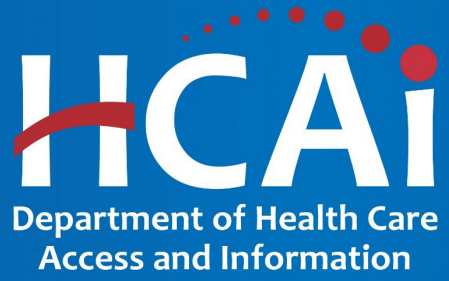

**Thank you!**

Nanci Timmins  
Chief Fire and Life Safety Officer



Item #15

HBSB Chair and Vice-Chair Election

- Board Members vote to elect a Chair and Vice-Chair to officially take office on January 1, 2025
- Discussion and public input

*Facilitators: Michael Foulkes and Michael O'Connor (or designees)*

Item #16

Comments from the Public/Board Members on Issues not on this Agenda

The Board will receive comments from the Public/Board Members. Matters raised at this time may be taken under consideration for placement on a subsequent agenda.

*Facilitator: Louise Belair (or designee)*

## Item #17      Adjournment

---

The next Full Board Meeting is December 11 - 12, 2024, in the Sacramento HCAI Office.