

Facilities Development Division

California's Building Department for Hospitals

Paul A. Coleman, Architect, Deputy Director

Chris Tokas, SE, Deputy Division Chief

John Gillengerten, SE, Senior Structural Engineer

How to Remove Acute Care Services from an SPC-1 Hospital Building

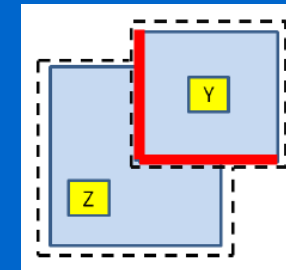
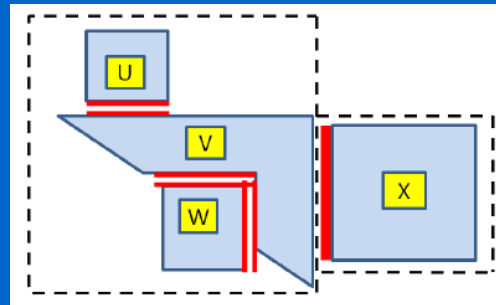
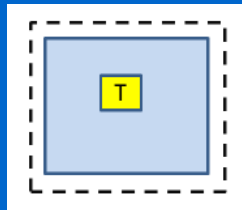

- Introduction
- Definitions
- SB 1953 Compliance Options
- Process
 - General requirements
 - Buildings that will remain under OSHPD jurisdiction
 - Buildings to be removed from OSHPD jurisdiction

CAC Code Section 1.4.5.1.4

Chapter 6, Section 1.4.5.1.4 2010 California Administrative Code (CAC)

1.4.5.1.4 A hospital building from which acute care services and beds have been removed shall not provide such services unless it has been modified to comply with the requirements of SPC 5 and NPC 4 or 5. Prior to use for acute care service, the SPC and/or NPC of the hospital building shall be changed in accordance with Section 1.4.5.1.1

- The objective of this process for the removal of *SPC Buildings* from *general acute care service* is to establish:
 - No acute care basic services or supplemental services are provided in a *SPC Building* removed from general acute care service
 - The hospital continues to comply with all requirements after the *SPC Building* has been removed from *general acute care service*

Introduction

- To comply with the requirements of SB 1953, hospital facilities may consider removal of all *general acute care services* from nonconforming hospital buildings
- CAN 1-6-1.4.5.1.4 is a guide to the process of removing all *general acute care services* from a building, and potentially removing the building from OSHPD jurisdiction.
- Due to the broad range of site specific conditions that will be encountered, no document can provide comprehensive guidance
- The CAN illustrates the approach to the process in principle

- The removal of *general acute care services* from a building may result in a change of:
 - Use,
 - Occupancy,
 - Function,
 - Licensure,
 - A combination of the above for all or a part of the building
- It may also involve a change of the authority having jurisdiction from OSHPD to the local enforcement agency
 - The *Building* meets specified seismic separation and fire protection criteria.

Definitions

- There are diverse definitions of the terms “building” and “hospital building” in the Alfred E. Alquist Hospital Facilities Seismic Safety Act of 1983 and the CBSC
- For the purposes of CAN 1-6-1.4.5.1.4, terms have been defined to clarify the process of removing a building from general acute care service
- When referring to a defined term it will be shown in *italics*
- See the CAN for full (unabridged) definitions

- **GENERAL ACUTE CARE SERVICE:** means healthcare services that must be provided in a general acute care hospital building, as defined in 2010 California Administrative Code (CAC), Chapter 6, Article 1, Section 1.2, Definitions.
- **BUILDING:** is defined by the area included within surrounding exterior walls or any combination of exterior walls and fire walls. *A Building will consist of one or more SPC Buildings.* (Based on the definition of **AREA, BUILDING**, 2010 California Building Code (CBC), Section 502.1)

- **SPC BUILDING** is defined as a structure with an independent vertical and lateral load resisting system and a seismic performance category assigned by OSHPD.
- **SPC SEISMIC SEPARATION** means a building separation in accordance with the California Administrative Code Chapter 6 Section 3.4.
- **STRUCTURAL SEPARATION** means a separation gap between adjacent structures sufficient to avoid damaging contact, complying with the current structural provisions of the CBC.

FREESTANDING NONHOSPITAL BUILDING:

means a *Building* that does not contain any *general acute care services* and meets the following criteria:

1. Structural separation shall comply with the applicable provisions of the California Building Code.
2. Fire-resistive-rated construction separations shall comply with the applicable provisions of the California Building Code.
3. Buildings on the same lot shall comply with the height and area limitations of the California Building Code.

DETACHED HOSPITAL BUILDING: means a *Building* containing *general acute care services* that meets the following criteria:

1. Structural separation shall comply with the applicable provisions of the California Building Code
2. Fire-resistive-rated construction separations shall comply with the applicable provisions of the California Building Code
3. Buildings on the same lot shall comply with the height and area limitations of the California Building Code

Definitions - Summary

- ***General Acute Care Service***
- ***Building***
- ***SPC Building***
- ***SPC Seismic Separation***
- ***Structural Separation***
- ***Freestanding Nonhospital Building***
- ***Detached Hospital Building***

SPC Buildings and Detached Hospital Buildings

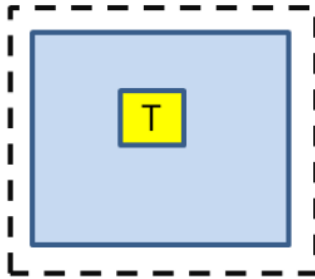

FIGURE 1A.

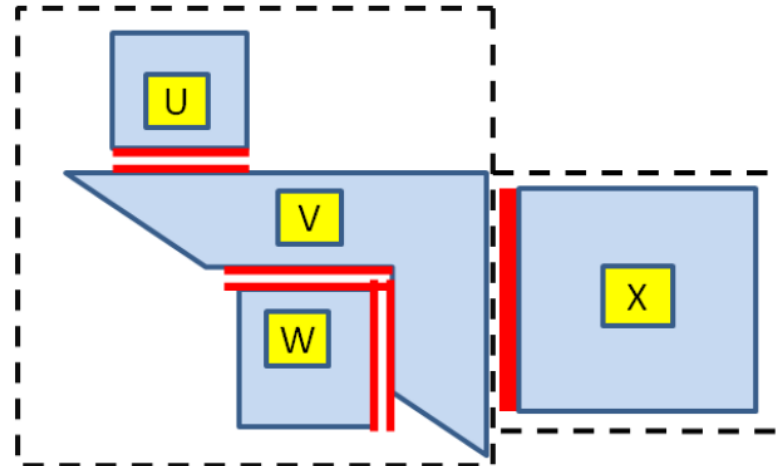

FIGURE 1B.

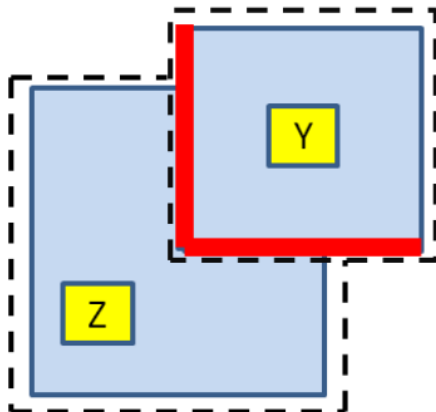



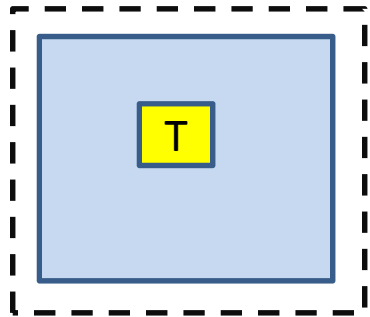

FIGURE 1C.

Legend

-  = SPC Building
-  = Detached Hospital Building
-  = Fire Wall and Structural Separation
-  = SPC Seismic Separation

SPC Building "T"



- *SPC Building "T"* is a *Detached Hospital Building*
- It is not adjacent to any other structure

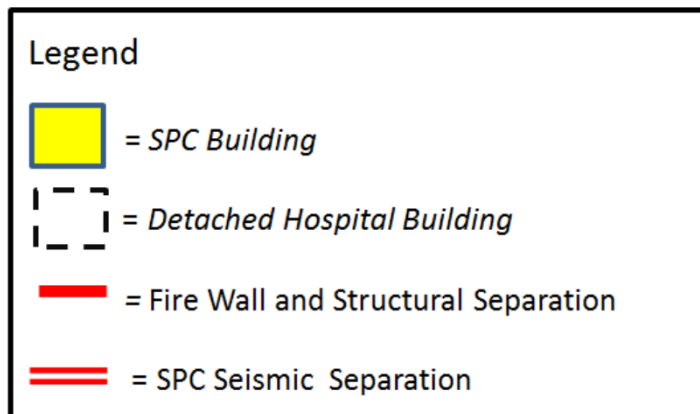

SPC Buildings "U", "V", "W", and "X"

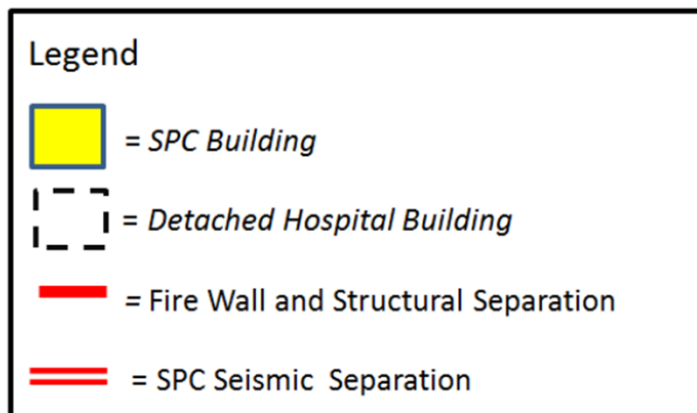
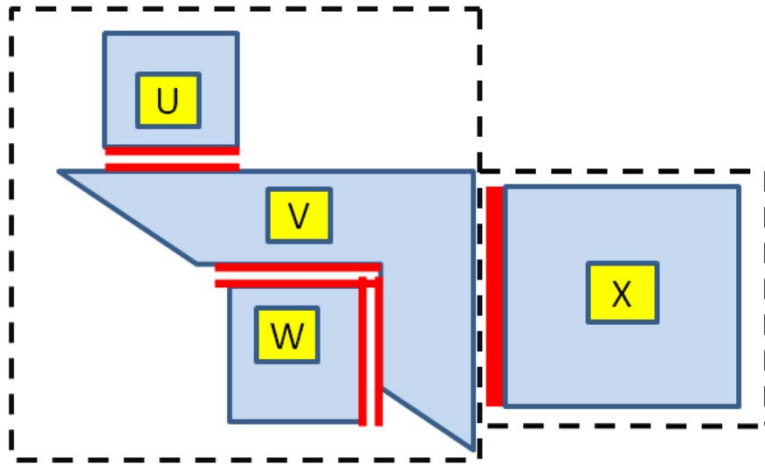

- SPC Buildings "U", "V", and "W" together form a single *Detached Hospital Building*
 - SPC Buildings "U", "V", and "W" have independent vertical and lateral structural systems with SPC *Seismic Separations* between them
 - They are not separated by exterior walls and/or fire walls
- SPC Building "X", is a *Detached Hospital Building* with CBC compliant *Structural Separation* and fire walls between it and SPC Building "V"

SPC Buildings "Y" and "Z"

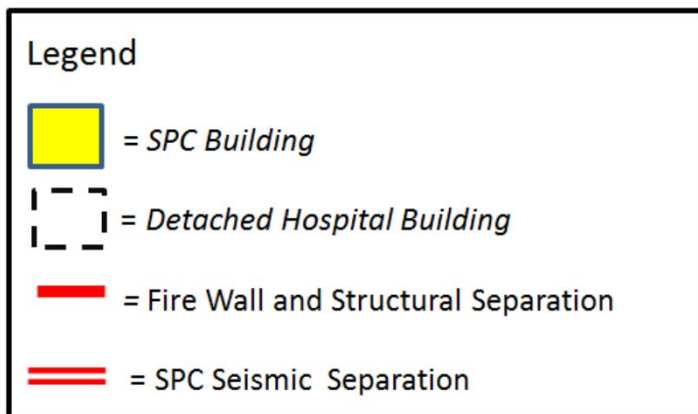
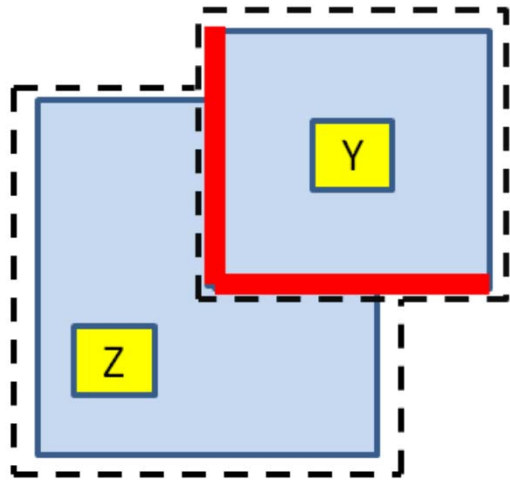

- *SPC Buildings "Y" and "Z" are Detached Hospital Buildings*
- Although they are adjacent, they are separated by fire walls, and the *Structural Separation* joint between them complies with the current CBC structural provisions

Detached and Freestanding Buildings

- The distinction between *SPC Buildings* and *Detached Hospital Buildings* or *Freestanding Nonhospital Buildings* is important
 - Jurisdiction is determined for *Buildings* that are freestanding.
 - By statute, OSHPD preempts the local jurisdiction for *Detached Hospital Buildings*
 - Split jurisdiction for *Buildings* removed from *general acute care service* is not permitted

SPC Buildings and Detached Hospital Buildings

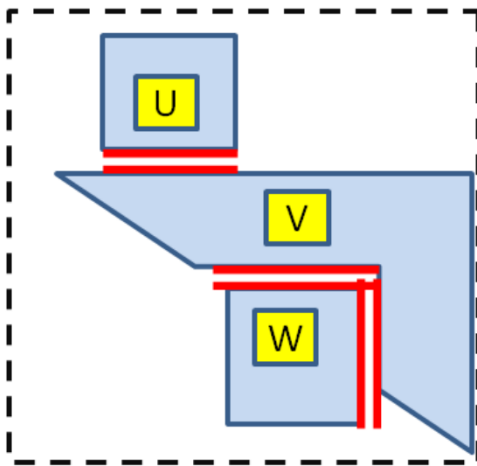

- If *SPC Buildings* "U" and "V" are removed from *general acute care service* and *SPC Building* "W" remains in *general acute care service*, OSHPD will retain jurisdiction over all three *SPC Buildings*
- If any *SPC Buildings* in the group remain in *general acute care inpatient service*, the whole is classified as a *Detached Hospital Building*, and the entire *Detached Hospital Building* must remain under OSHPD jurisdiction

Conforming versus Nonconforming Buildings

- Conforming Buildings are *SPC Buildings* that were originally constructed in compliance with the 1973 or subsequent editions of the CBC
- All other *SPC Buildings* are Nonconforming Buildings
- The concepts of Conforming and Nonconforming Buildings apply only to *SPC Buildings*
- *A Detached Hospital Building:*
 - May consist of multiple *SPC Buildings*
 - May include both Conforming and Nonconforming Buildings

Removal from Acute Care Service

INTERPRETATION

Removal from Acute Care Service

- The process to remove a SPC Building from general acute care service can be approached systematically.
- The following flowcharts provide graphic representation of the process
 - The General Process shows the major steps required to remove a SPC Building from general acute care service.
 - The Detailed Process provides step-by-step guidance. The letters in the flowchart boxes correspond to the Items listed below.

Removal from Acute Care Service – General Process

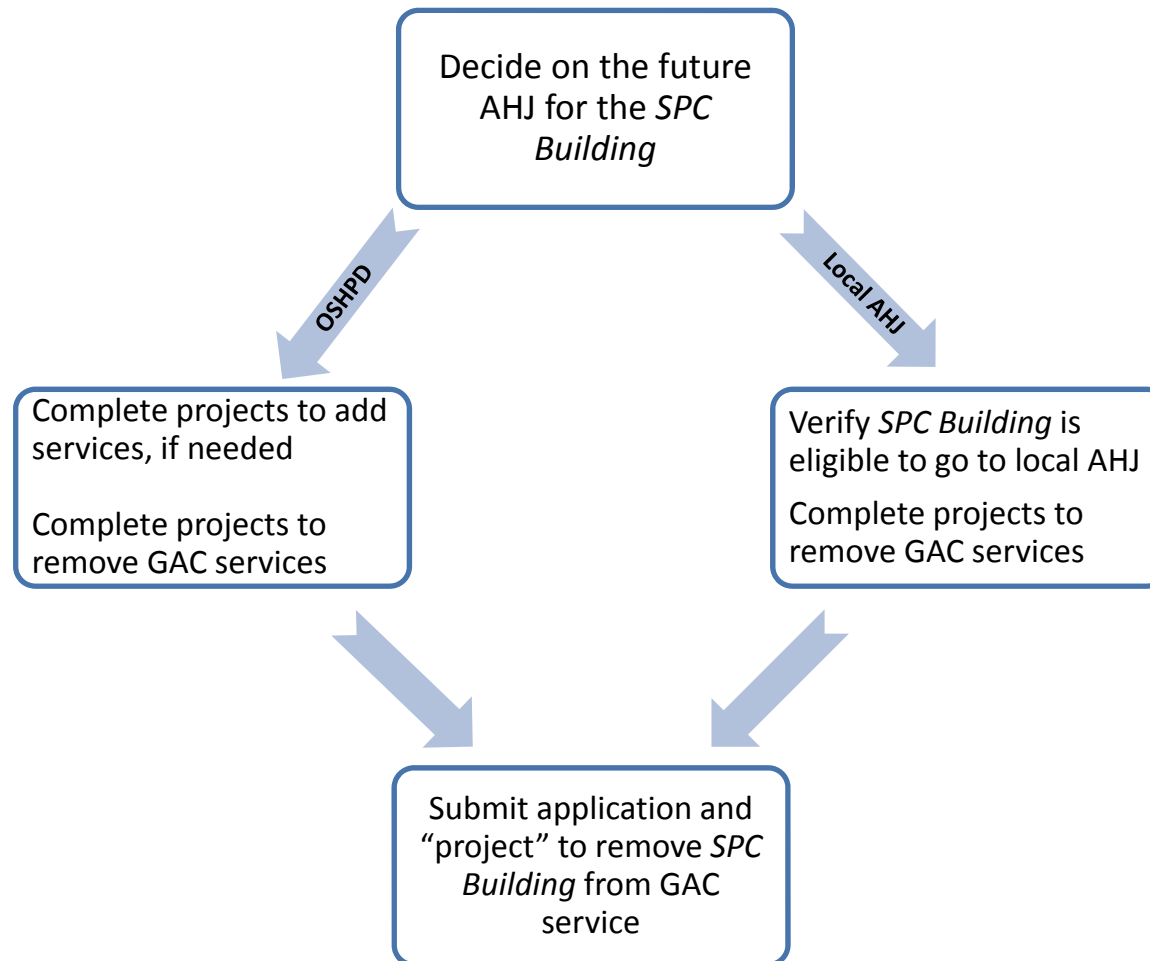

Removal from Acute Care Service – Detailed Process

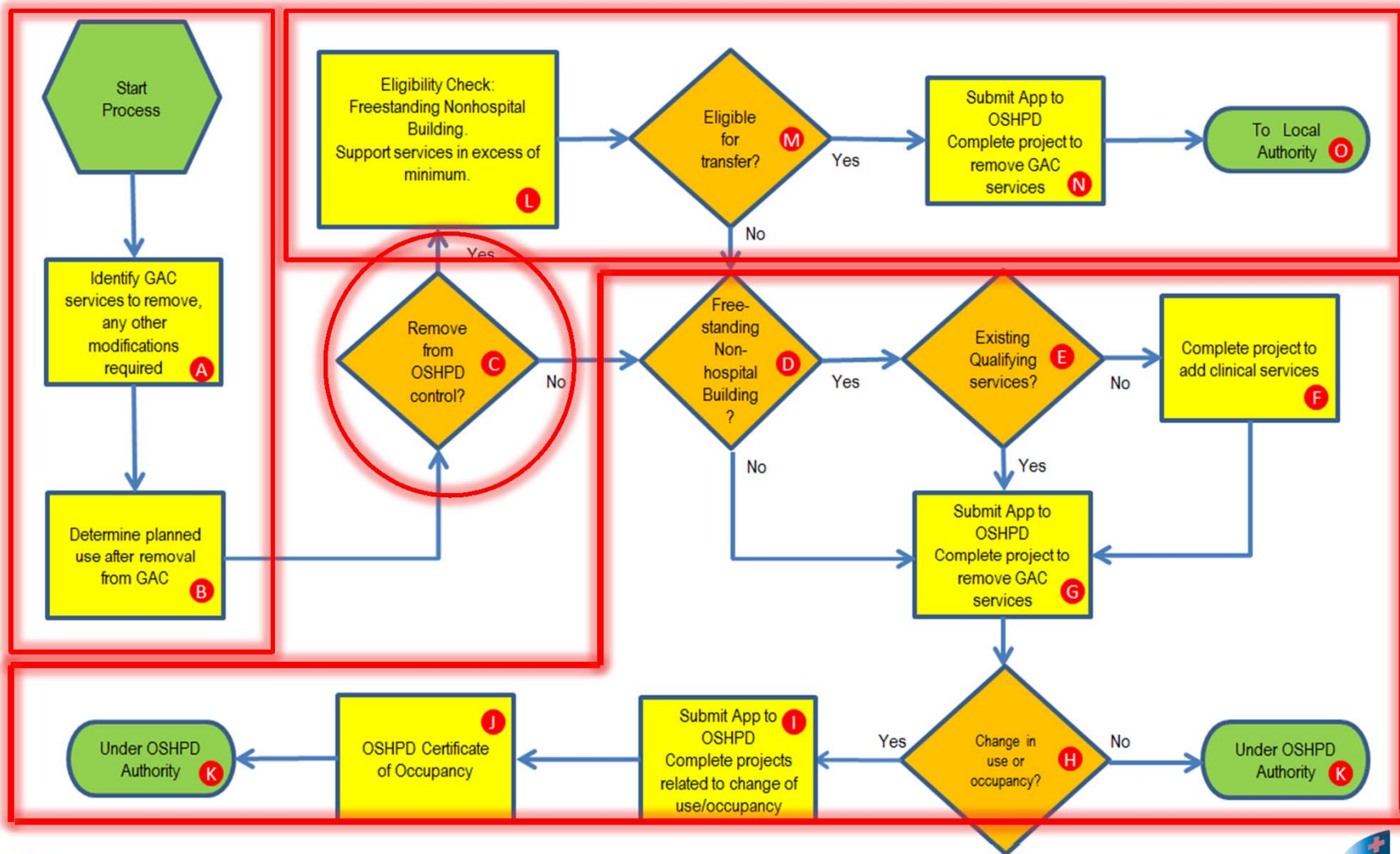

Step A: Identify Acute Care Services to be Removed

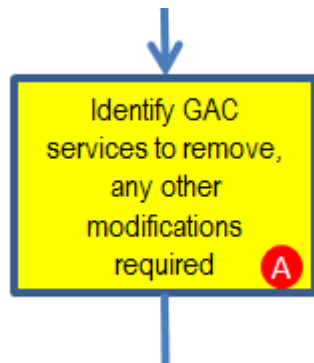

- The first step in the process is to identify the *general acute care services* that must be removed from the *SPC Building* in order to comply with the provisions of SB 1953
- Identify any construction that may be required to separate the *SPC Building* from the remaining general acute care hospital

Step A: Identify Acute Care Services to be Removed

- After the general acute care services are removed from the SPC Building the following criteria must be met:
 1. No acute care basic services or supplemental services are provided in a *SPC Building* removed from general acute care service.
 2. The hospital complies with all egress requirements
 3. No *SPC Building* removed from *general acute care service* (or building not under OSHPD jurisdiction) is used as a smoke compartment for any GAC hospital building

Step A: Identify Acute Care Services to be Removed

4. Structural and fire-resistive rated construction separation between the *SPC Building* removed from *general acute care service* and adjacent buildings meet code requirements

Exception: *SPC Seismic Separation* is OK for *SPC Buildings* that will remain under OSHPD jurisdiction

Step A: Identify Acute Care Services to be Removed

5. If a *SPC Building* removed from general acute care service shares a common fire alarm system with the GAC hospital:
 - The main fire alarm control panel must be located in a GAC hospital building.
 - It must be in a separate zone monitored by the main fire alarm control panel
 - Provide flex connections for conduits/conductors crossing seismic separation joints
 - *SPC Buildings* going to local jurisdiction must have an independent fire alarm system

Step A: Identify Acute Care Services to be Removed

6. If a *SPC Building* removed from *general acute care service* shares a fire sprinkler system with the GAC hospital:
- Provide an isolation valve with a tamper switch to isolate the portion of the system serving the *SPC Building*
 - Provide flex connections in pipes crossing seismic separation joints
 - Sprinkler systems that originate in the *SPC Building* can not feed the GAC hospital
 - *SPC Buildings* going to the local jurisdiction must have their own independent fire sprinkler system

Step A: Identify Acute Care Services to be Removed

7. Required patients access can not pass through a *SPC Building* removed from *general acute care service* or buildings not under OSHPD jurisdiction
8. The primary accessible entrance to the hospital can not be through a *SPC Building* removed from *general acute care service* or buildings not under OSHPD jurisdiction
9. No utilities servicing GAC hospital buildings may originate in or pass through, over, or under, a *SPC Building* removed from *general acute care service* or buildings not under OSHPD jurisdiction

Step A: Identify Acute Care Services to be Removed

10. If utilities originating in a GAC hospital building feed a *SPC Building* removed from *general acute care service*, fail safe shut-off valves and/or disconnects shall be provided that permit isolation of the *SPC Building* from the hospital utilities
- Flexible connections shall be provided for all utilities crossing seismic separation joints

Removal from Acute Care Service – Detailed Process

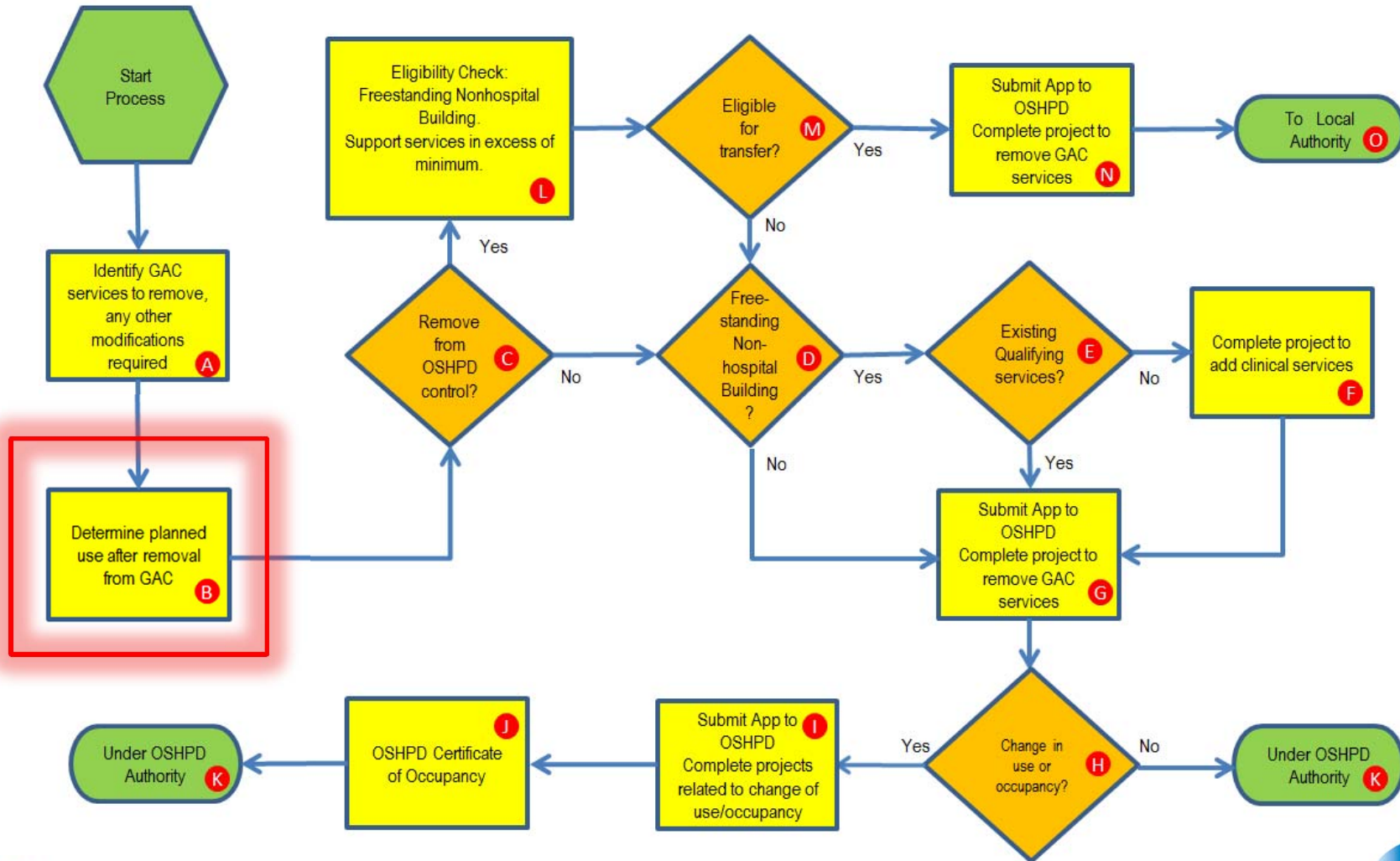

Step B: Determine Planned Use of the Building

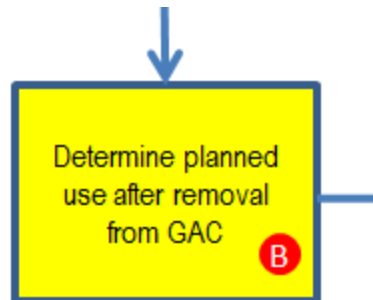

- The facility owner must determine the planned disposition of the *SPC Building*, after all *general acute care services* have been removed.
 - Demolition
 - Transfer of jurisdiction to the local building authority
 - Maintaining the building under OSHPD jurisdiction
- Depending on the particular circumstances, not all options will be available
- SPC Buildings that are not also Freestanding Nonhospital Buildings must remain under OSHPD jurisdiction.

Removal from Acute Care Service – Detailed Process

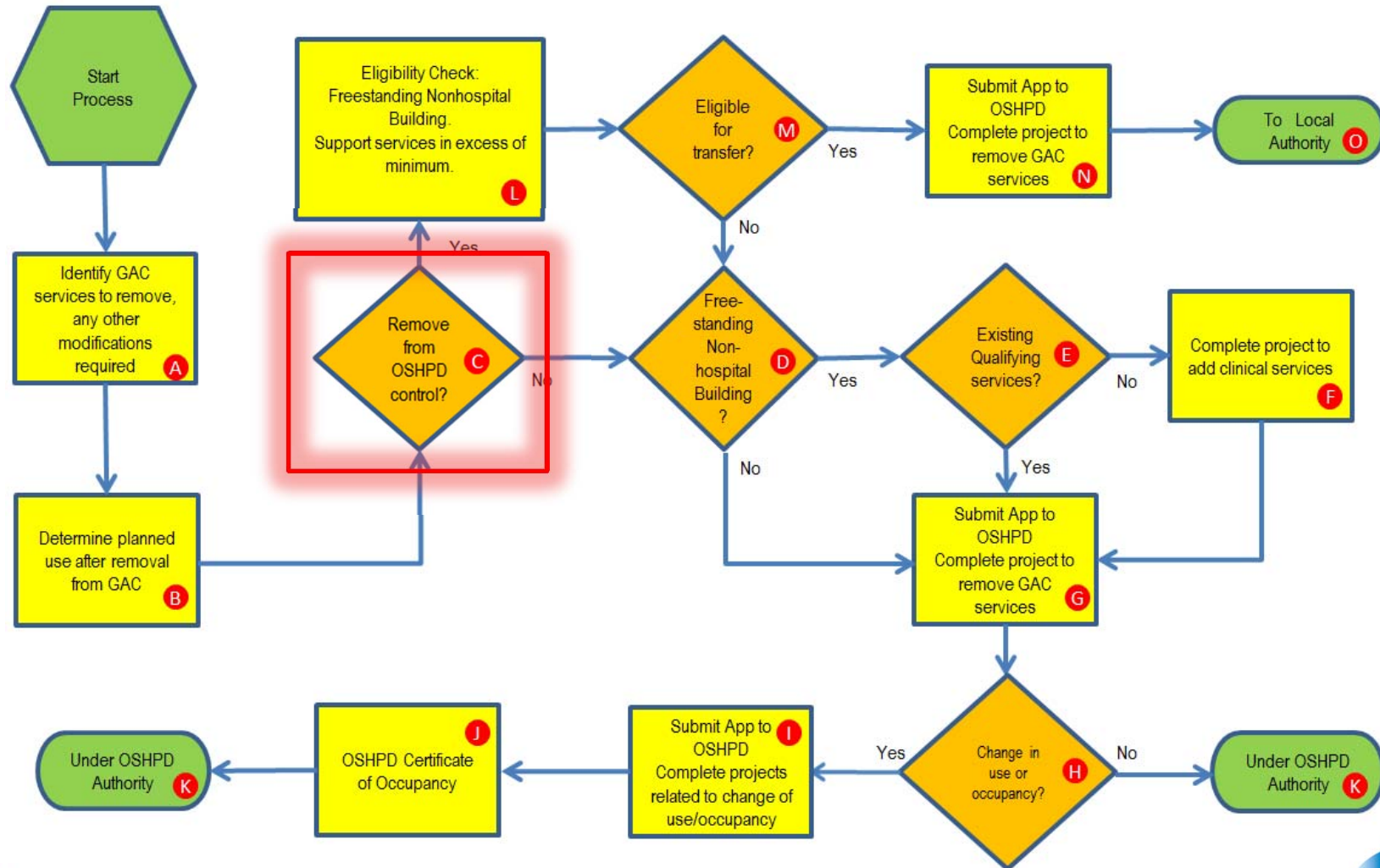

Step C: Determine Jurisdiction of the Building

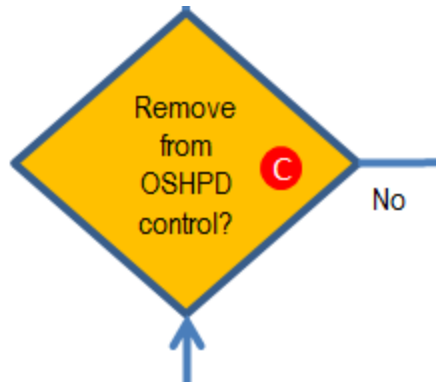

- The facility owner determines whether the SPC Building is to remain under OSHPD jurisdiction after all general acute care services have been removed
- A building cannot be under split or multiple jurisdictions
- The processes for buildings that will remain under OSHPD jurisdiction are presented in Items D through K.
- The process to determine eligibility for a change of jurisdiction, and for completing the transfer of jurisdiction to the local building authority are presented in Items L through O

Flowchart Figure 2, Items D through K

**PROCESS FOR *SPC BUILDINGS* REMAINING
UNDER OSHPD JURISDICTION**

Removal from Acute Care Service – Detailed Process

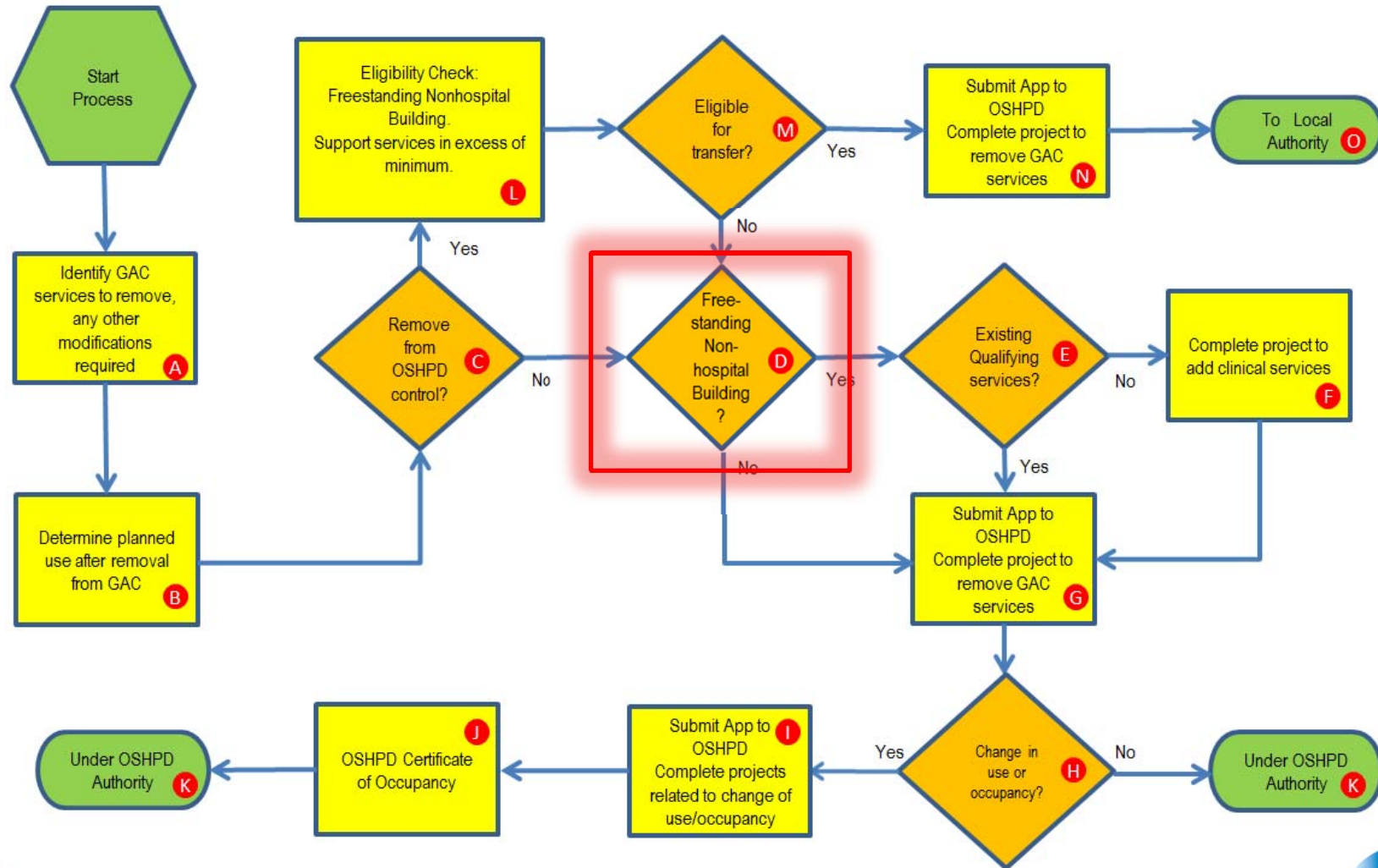

Step D: Determine if the Building is Freestanding

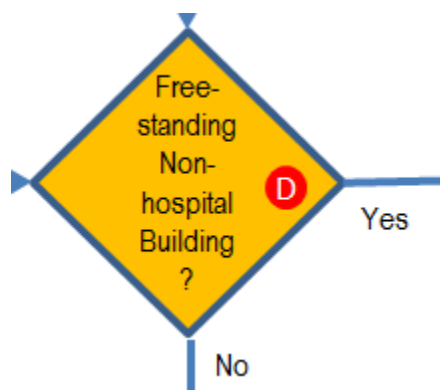

If the *SPC Building* does not qualify as a *Freestanding Nonhospital Building*, proceed to Item G

- To be considered a *Freestanding Nonhospital Building*, it must be:
 - Structurally independent (it may consist of one or more *SPC Buildings*)
 - A *Structural Separation* must be provided between the *Freestanding Nonhospital Building* and all adjacent structures
- Height and area limits, fire-resistive-rated construction separations and/or open space/frontage between the *Freestanding Nonhospital Building* and all adjacent structures must comply with the CBC.

Removal from Acute Care Service – Detailed Process

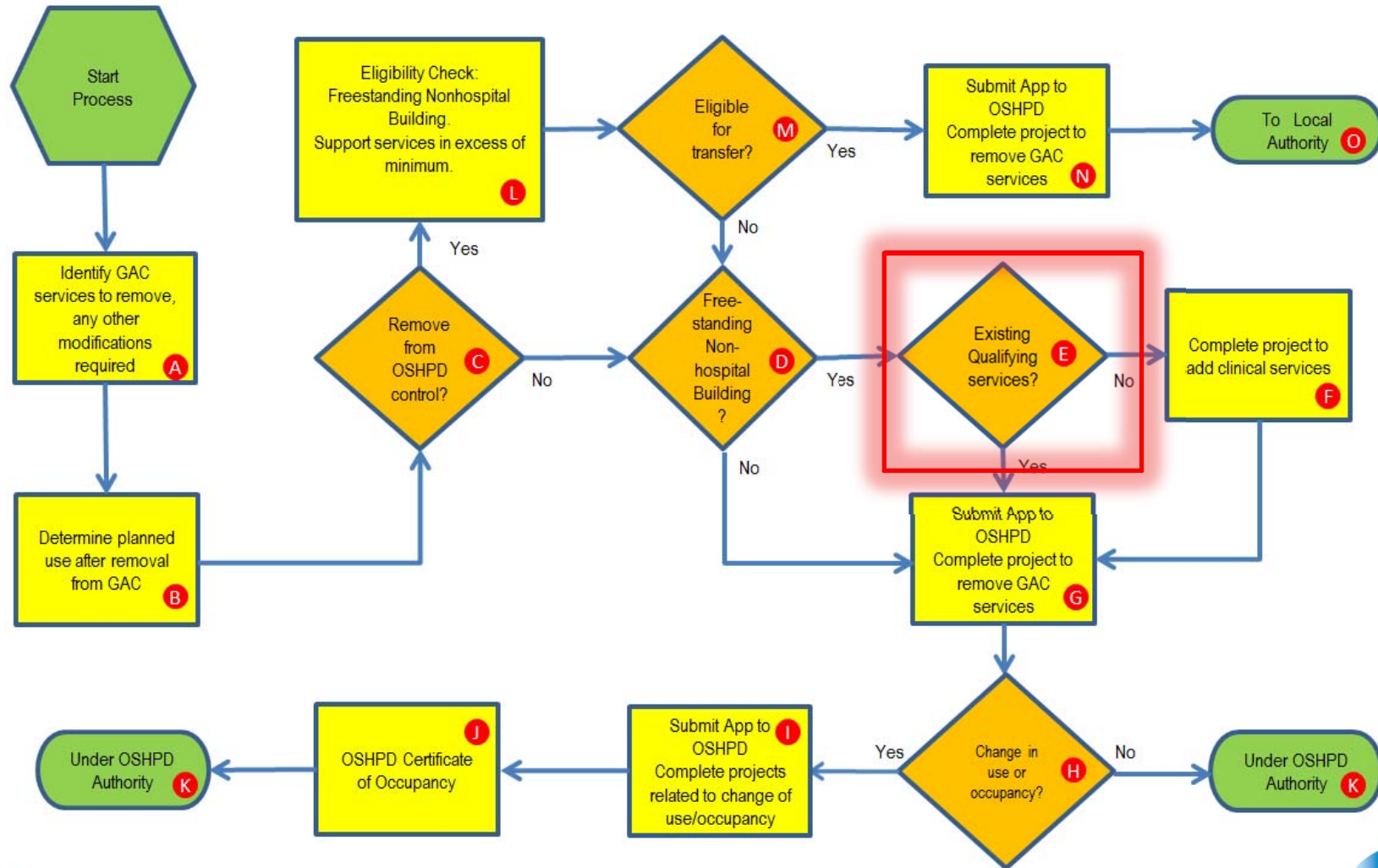

Step E: Check for Qualifying Services

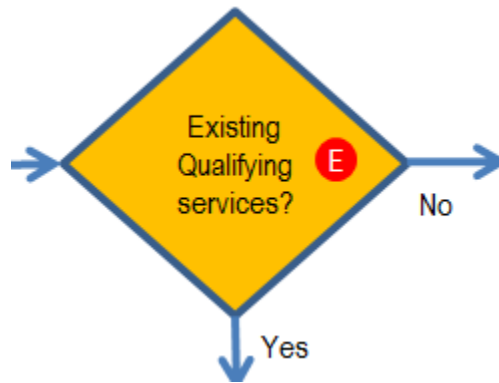

If the SPC Building does not contain qualifying services, proceed to Item F

- If the *SPC Building* qualifies for conversion to a *Freestanding Nonhospital Building*, determine if it currently contains one or more qualifying services that permit OSHPD to retain jurisdiction after removal of *general acute care services*. Qualifying services include:
 1. Services considered “Outpatient Clinical Services” as defined in H&S § 129730 (a)
 2. Outpatient portions of certain services such as surgery, rehab, etc. (no more than 25% in-patient use)
 3. Services that duplicate Basic Services, as defined in H&S §1250, or that are not required for facility licensure (no more than 25% in-patient use)

Step E: Check for Qualifying Services

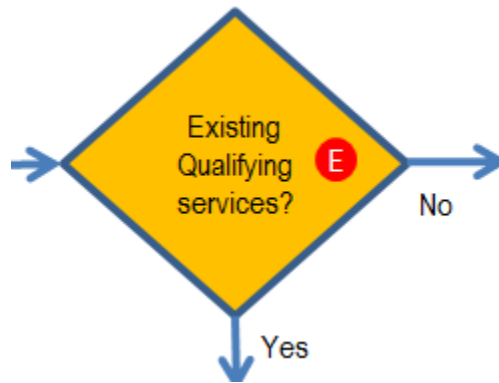

If the SPC Building does not contain qualifying services, proceed to Item F

- Hospital support services listed in Item E.1 that are located in a *SPC Building* at the *time general acute care services* are removed may remain
 - The State Department of Public Health must certify to the Office that it has received and approved a plan that demonstrates how the health facility will continue to provide all basic services in the event of any emergency when the *SPC Building* may no longer remain functional
 - Certification must be received by Office prior to removal of the SPC Building from general acute care service

Step E: Check for Qualifying Services

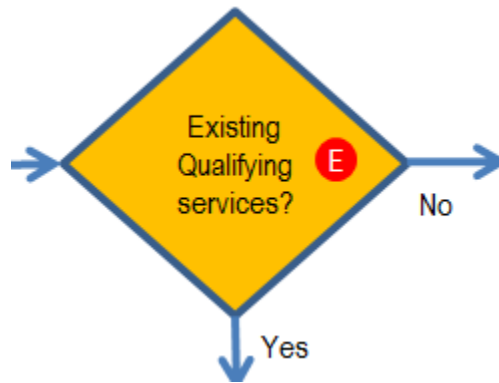

If the SPC Building does not contain qualifying services, proceed to Item F

- Existing approved non-acute services or Outpatient Clinical Services listed in Items E.2 and E.3 that are located in a SPC Building at the time general acute care services are removed may remain
- OSHPD may require evidence that the existing occupancies and services were in compliance with applicable codes at the time they were located in the building

Removal from Acute Care Service – Detailed Process

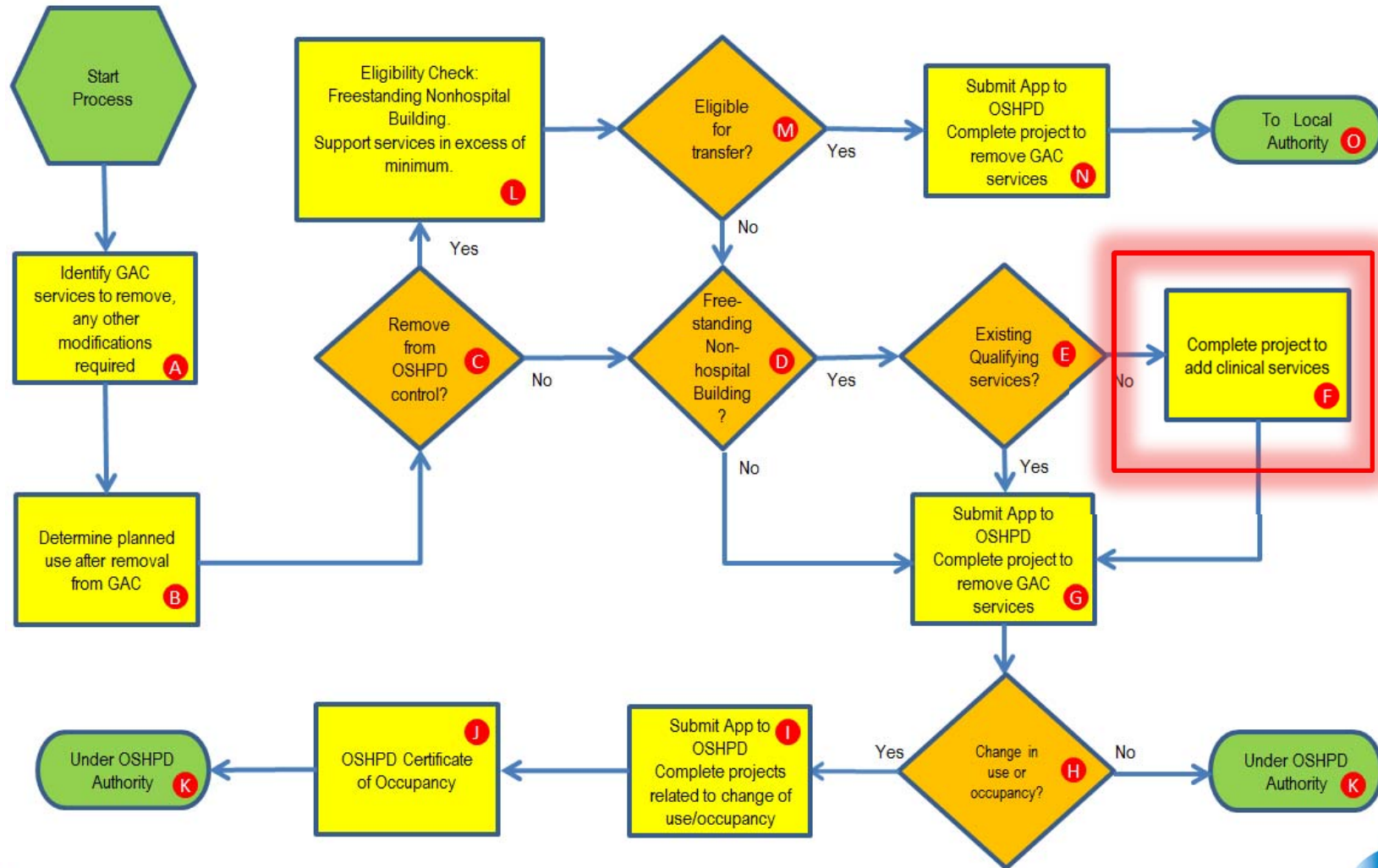

Step F: Add Qualifying Services

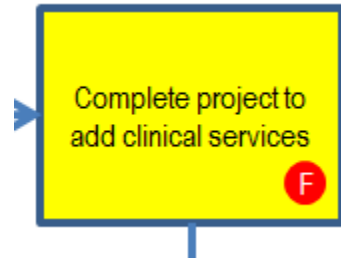

- If qualifying services are not present, they must be added to the building in order to remain under OSHPD jurisdiction
- Projects to add qualifying services must be complete prior to removal from general acute care service and conversion to a *Freestanding Nonhospital Building*
- A change of service or function for all, or a portion of the building requires compliance with the current requirements for that service, including accessibility requirements (refer to CAN 2- 11B) and other remodel/renovation requirements in CAN 2-102.6.

Removal from Acute Care Service – Detailed Process

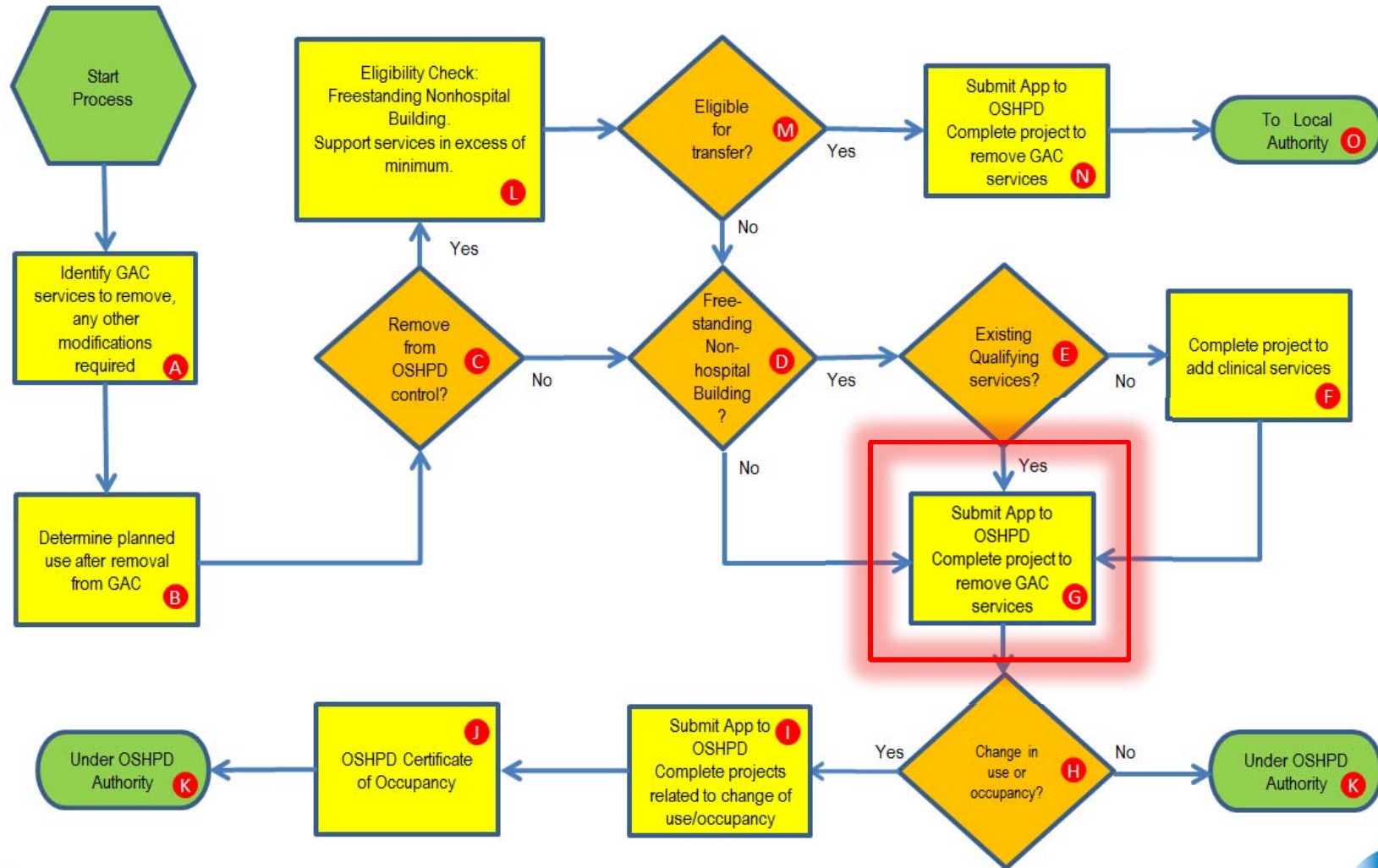

Step G: *Submit Project to Remove from GAC Service*



- Submit an application and project to the Office to remove the SPC Building from general acute care service, showing that all the criteria noted in Item A have been met.
- Any construction work needed to meet the requirements of Item A should be complete prior to submittal of the application and project to remove the SPC Building from general acute care service.

Removal from Acute Care Service – Detailed Process

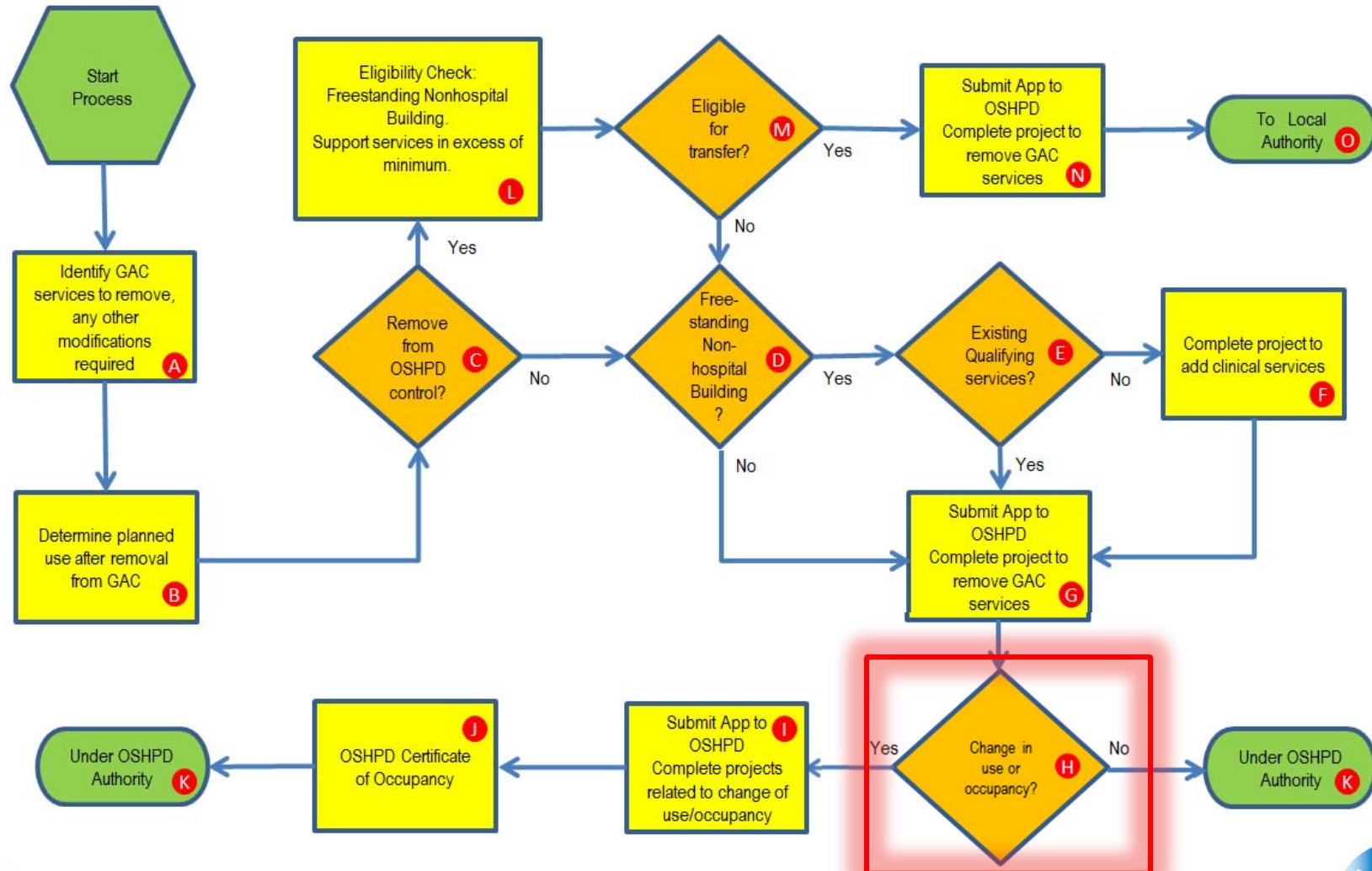

Step H: Check for Qualifying Services

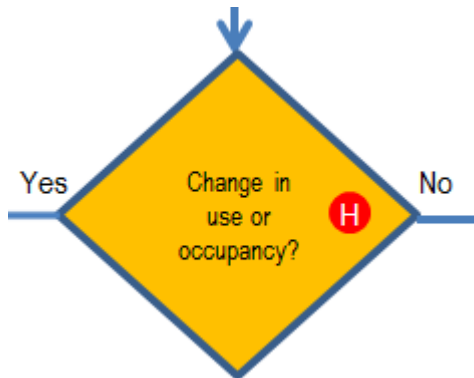

If there is no change of use, occupancy, or function, proceed to Item K

- Determine whether the removal of *general acute care services* from the *SPC Building* will result in a change of use, occupancy, or function.
- Approved non-acute care occupancies or services existing in the *SPC Building* at the time it is decommissioned may remain
 - The removal of *general acute care services* is not considered a change in occupancy (assuming no other changes are made)

Removal from Acute Care Service – Detailed Process

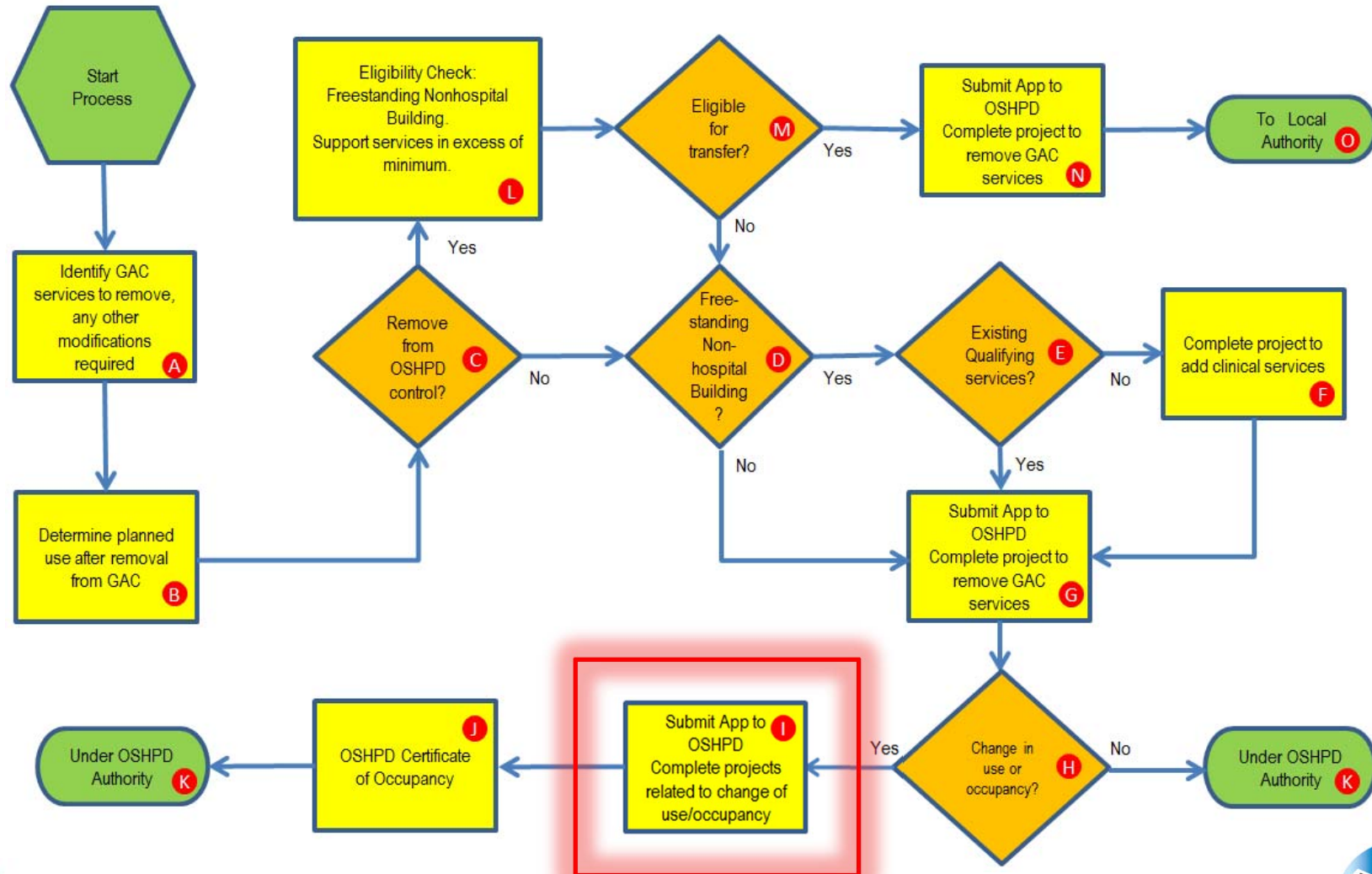

Step I: Complete Projects for Change of Use/Occupancy

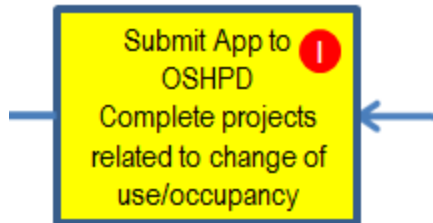

- When general acute care services are removed from a *SPC Building*, and new services provided are issued an initial license as a Skilled Nursing Facility or Acute Psychiatric Hospital, the *SPC Building* shall comply with the building code requirements or equivalent provisions of the California Building Standards Code at the time of application
- The California Department of Public Health, Licensing & Certification Division shall determine whether the new services constitute an original license

Removal from Acute Care Service – Detailed Process

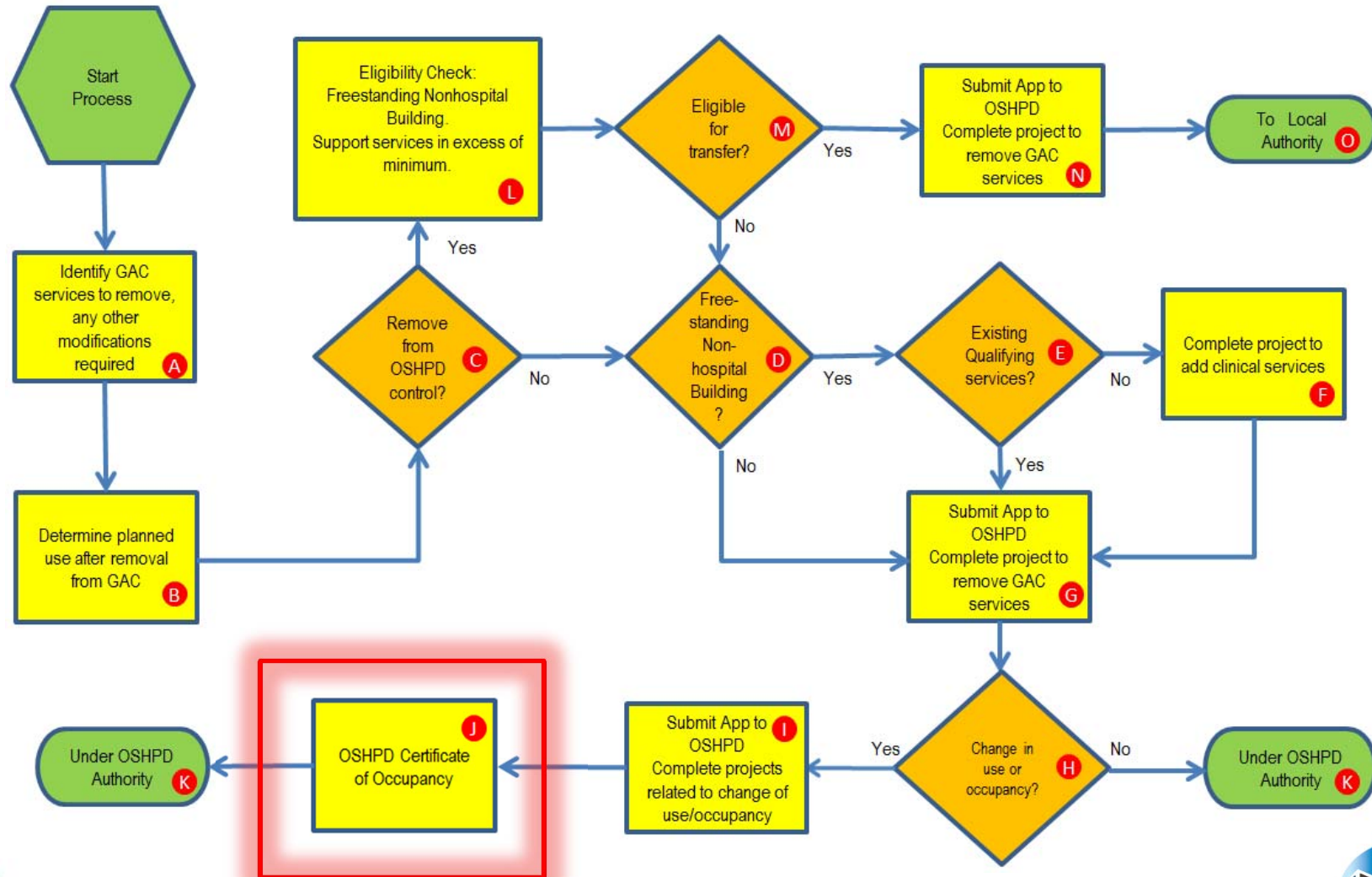

Step J: OSHPD Certificate of Occupancy



- The new occupancy group and division of the *Building* or *SPC Building*, and/or new service or function, shall be established
- A new certificate of occupancy shall be required for the *Building* or *SPC Building*

Removal from Acute Care Service – Detailed Process

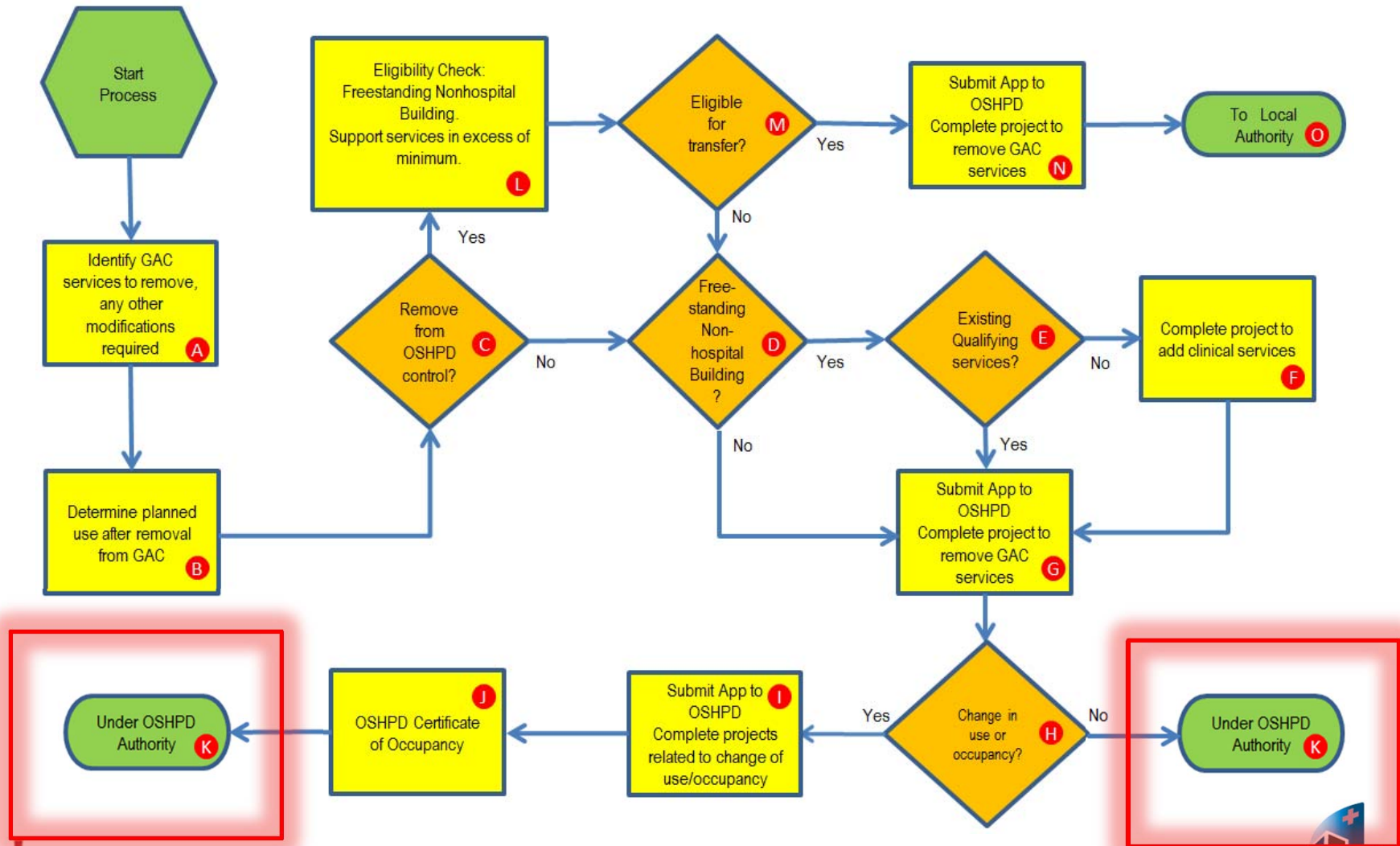

Step K: Under OSHPD Jurisdiction

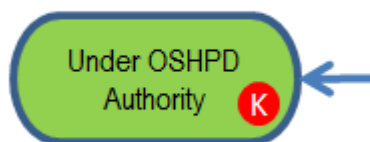

- Once the project submitted in Item G is closed with compliance, the *SPC Building* is removed from *general acute care service* and remains under OSHPD jurisdiction
- It is no longer subject to the provisions of Title 24, Part 1, Chapter 6. The Office shall notify the hospital owner that the building has been removed from *general acute care service*

Flowchart Figure 2, Items L through O

PROCESS FOR *FREESTANDING NONHOSPITAL BUILDINGS* PLACED UNDER LOCAL JURISDICTION

Removal from Acute Care Service – Detailed Process

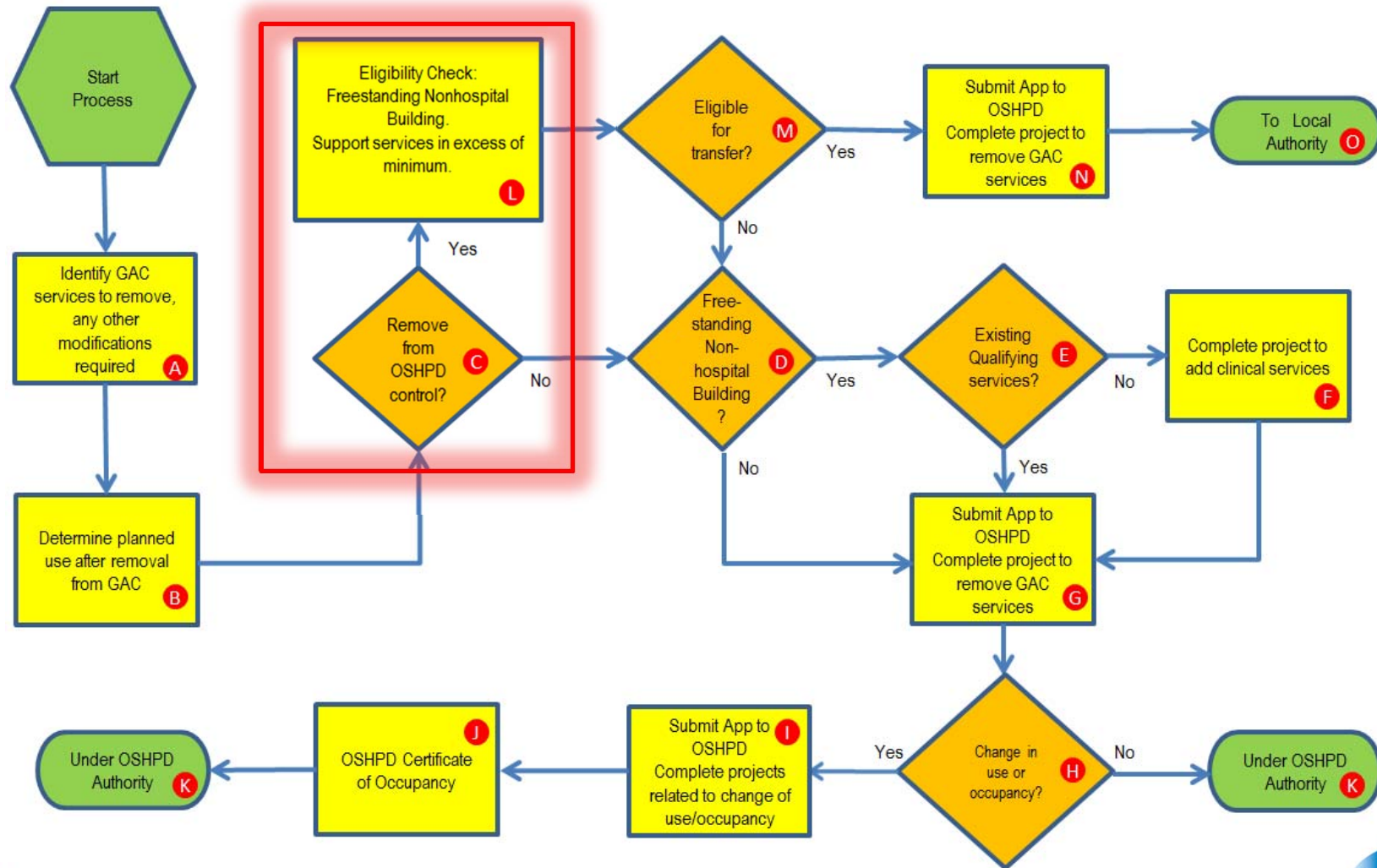

Step L: Check for Qualifying Services

Eligibility Check:
Freestanding Nonhospital
Building.
Support services in excess of
minimum.

L

- When removal of *general acute care services* will result in a *Building* being classified as a *Freestanding Nonhospital Building*, the Hospital may transfer jurisdiction to the local enforcement agency, provided it meets the following criteria:
 - It must be a *Freestanding Nonhospital Building*
 - Services/systems and utilities shall be separate and independent from those serving the buildings under OSHPD jurisdiction
 - If adjacent to a *Detached Hospital Building* and fire-resistive-rated construction separations are required, they shall be located in the *Detached Hospital Building*

Step L: Check for Qualifying Services

Eligibility Check:
Freestanding Nonhospital
Building.
Support services in excess of
minimum.

L

- With prior approval from the State Department of Public Health, hospital support services may be located in the building removed from acute care hospital service
 - Administrative services, central sterile supply, storage, morgue and autopsy, employee dressing rooms and lockers, janitorial and housekeeping service, and laundry.
 - DHS must certify that it has approved a plan that demonstrates the health facility will continue to provide all basic services in the event the *SPC Building* may no longer remain functional
 - Certification must be received by the Office prior to removal the *SPC Building* from GAC service

Step L: Check for Qualifying Services

Eligibility Check:
Freestanding Nonhospital
Building.
Support services in excess of
minimum.

L

- The local authority having jurisdiction may require fire-resistive-rated construction separations located in the *Freestanding Nonhospital Building*, in addition to those required in the *Detached Hospital Building*

Buildings eligible for transfer to local jurisdiction

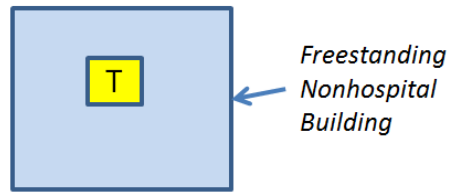

FIGURE 3A.

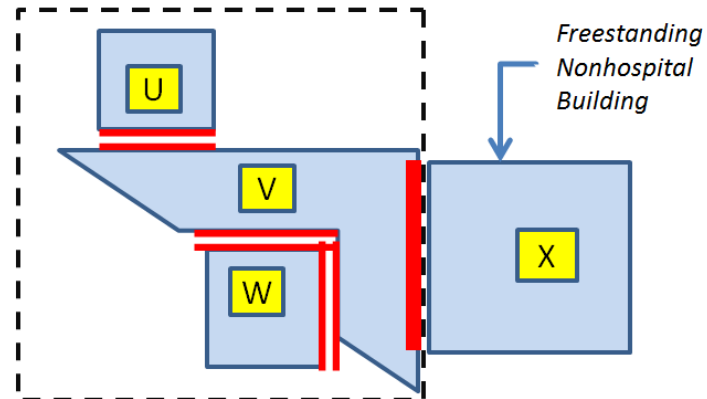

FIGURE 3B.

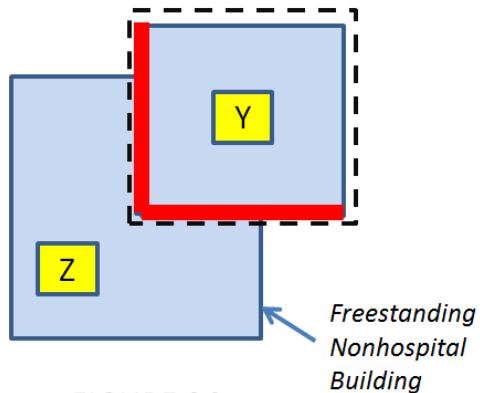
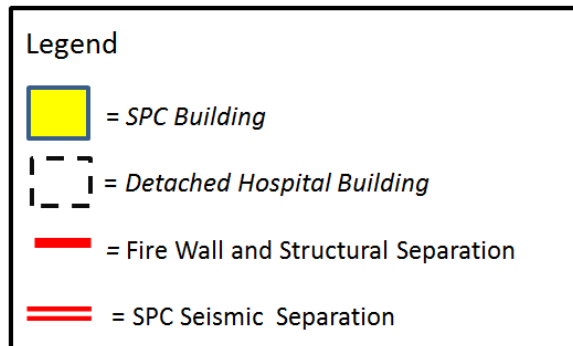
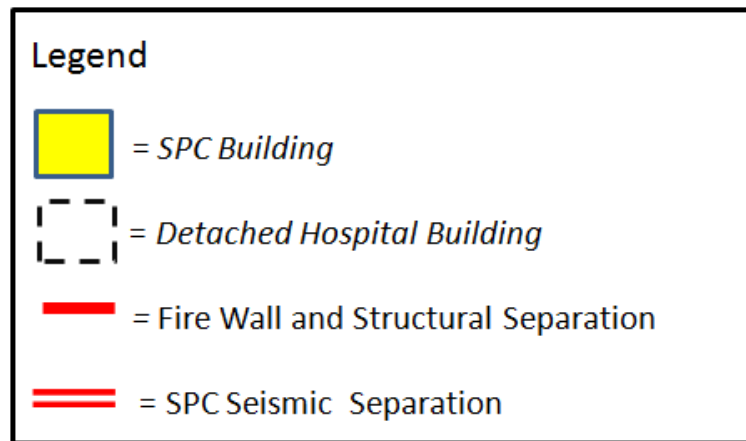
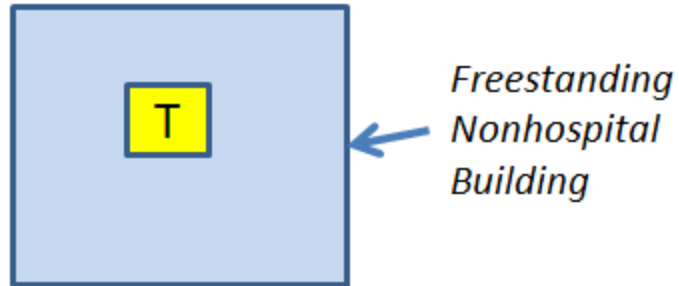

FIGURE 3C.



SPC Building "T"



- *SPC Building "T"* is a *Freestanding Nonhospital Building*
- It is not adjacent to another structure
- It is eligible for transfer to the jurisdiction of the local enforcement agency

SPC Buildings "U", "V", "W", and "X"

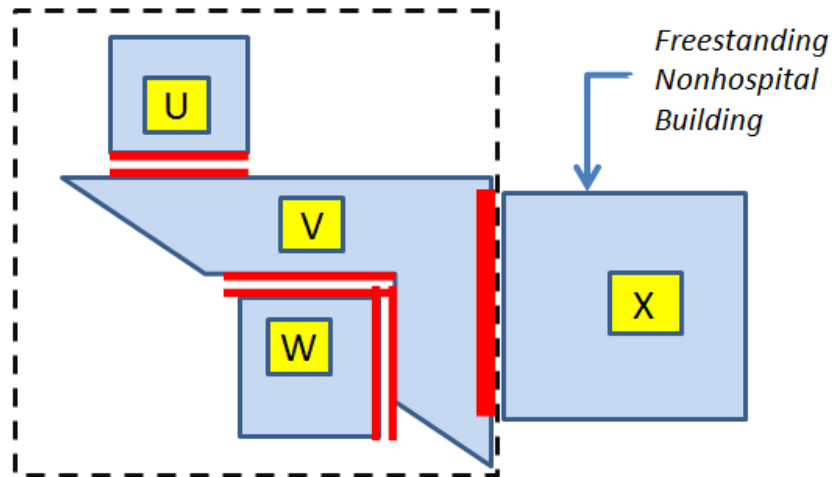

- SPC Buildings "U", "V", and "W" together form a single *Detached Hospital Building*.
 - They have independent structural systems and *SPC Seismic Separations*
 - Not separated by exterior walls and/or fire walls
 - If one or two are removed from *general acute care service*, they must remain under OSHPD jurisdiction. They are still part of a *Detached Hospital Building* (a portion remains as a general acute care hospital)
- SPC Building "X" is a *Freestanding Nonhospital Building* and is eligible for transfer to the jurisdiction of the local enforcement agency
 - CBC compliant *Structural Separation* and fire walls between it and SPC Building "V"
 - The fire-resistive-rated construction separation is in SPC Building "V" (a SPC Building under OSHPD jurisdiction)

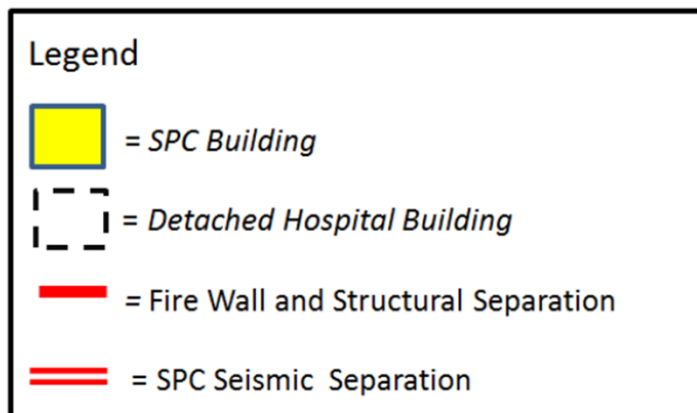

SPC Buildings "Y" and "Z"

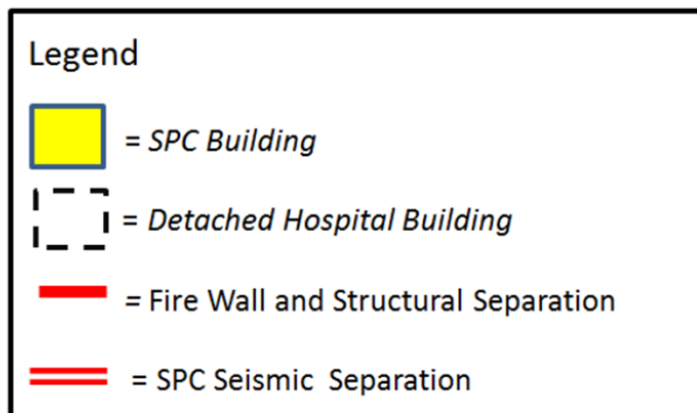
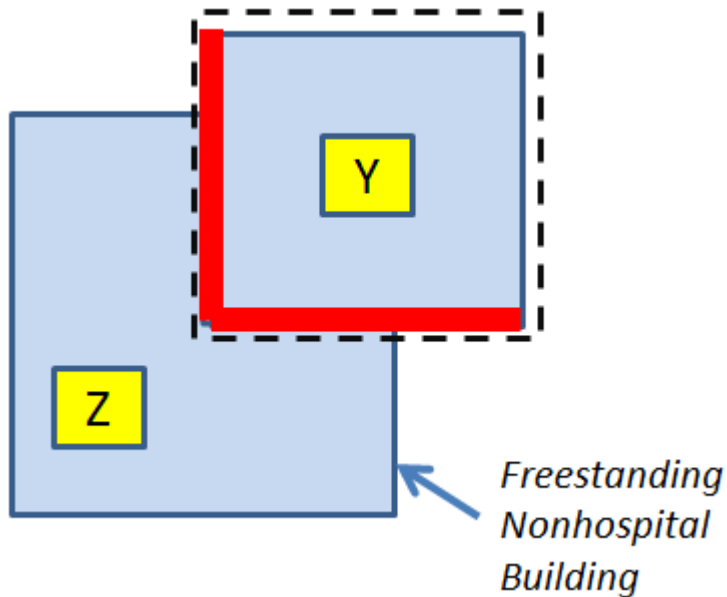

- SPC Building "Y" is a *Detached Hospital Building* and SPC Building "Z" is a *Freestanding Nonhospital Building*
- Although adjacent, they are separated by fire walls, and the structural separation joint between them complies with the current CBC structural provisions
- SPC Building "Z" is eligible for transfer to the jurisdiction of the local enforcement agency, provided the fire-resistive-rated construction separation is in the SPC *Building* remaining under OSHPD jurisdiction

Removal from Acute Care Service – Detailed Process

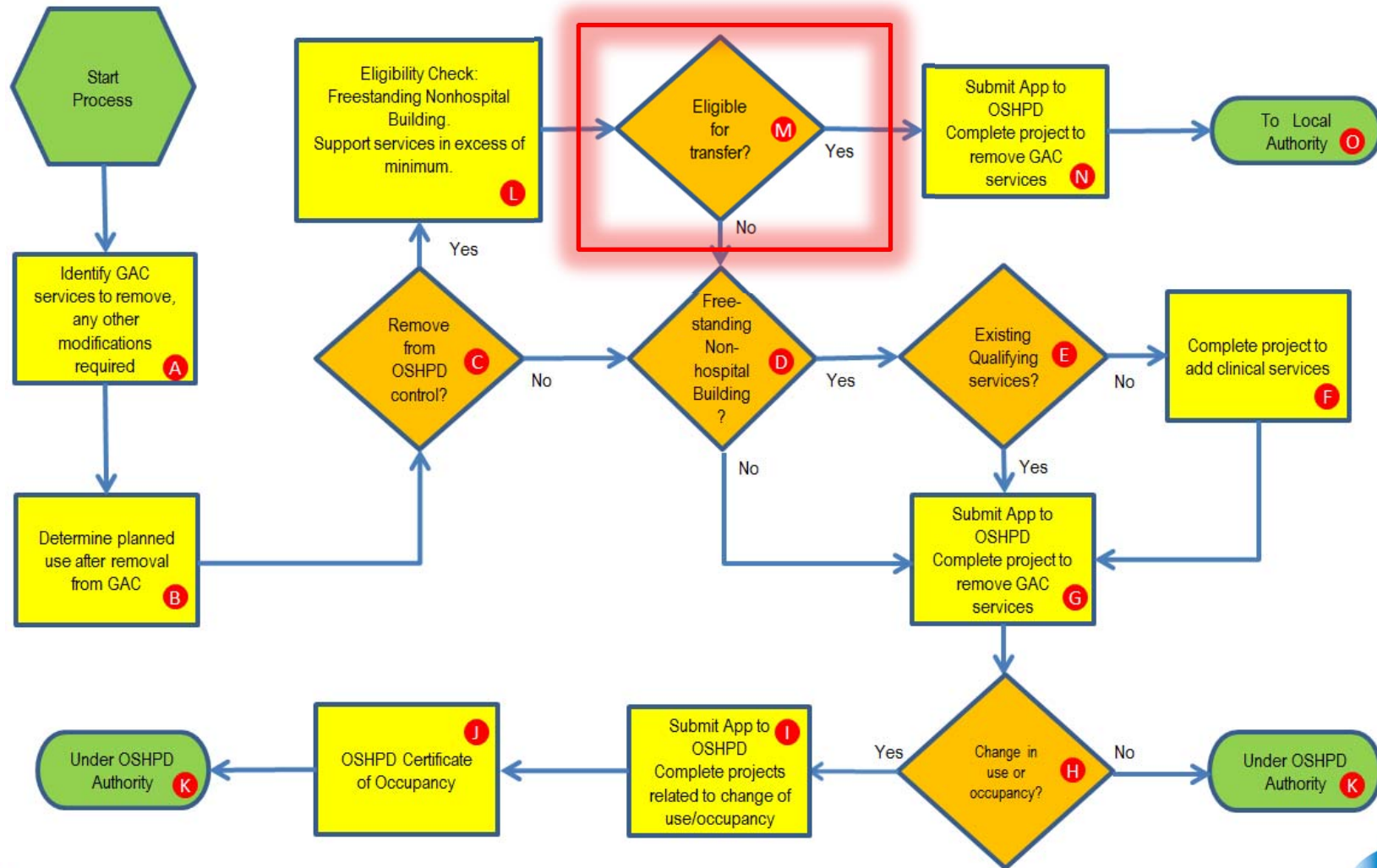

Step M: Check for Eligibility for Transfer

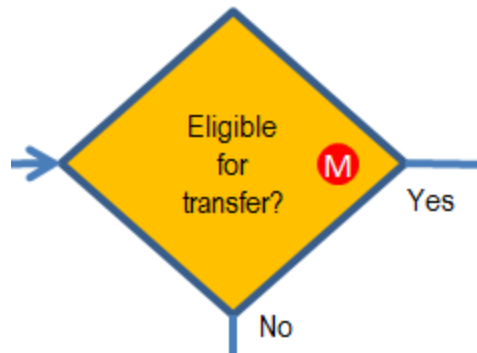

If the SPC Building is not eligible for transfer of jurisdiction, proceed to Item D

- *Freestanding Nonhospital Buildings* meeting all the requirements of Item A and Item L are eligible for a change of jurisdiction
- All other *SPC Buildings* must remain under the jurisdiction of OSHPD
- It is recommended that the owner confer with the local authority having jurisdiction and identify the implications of transfer of jurisdiction of the *Freestanding Nonhospital Building* to local control

Removal from Acute Care Service – Detailed Process

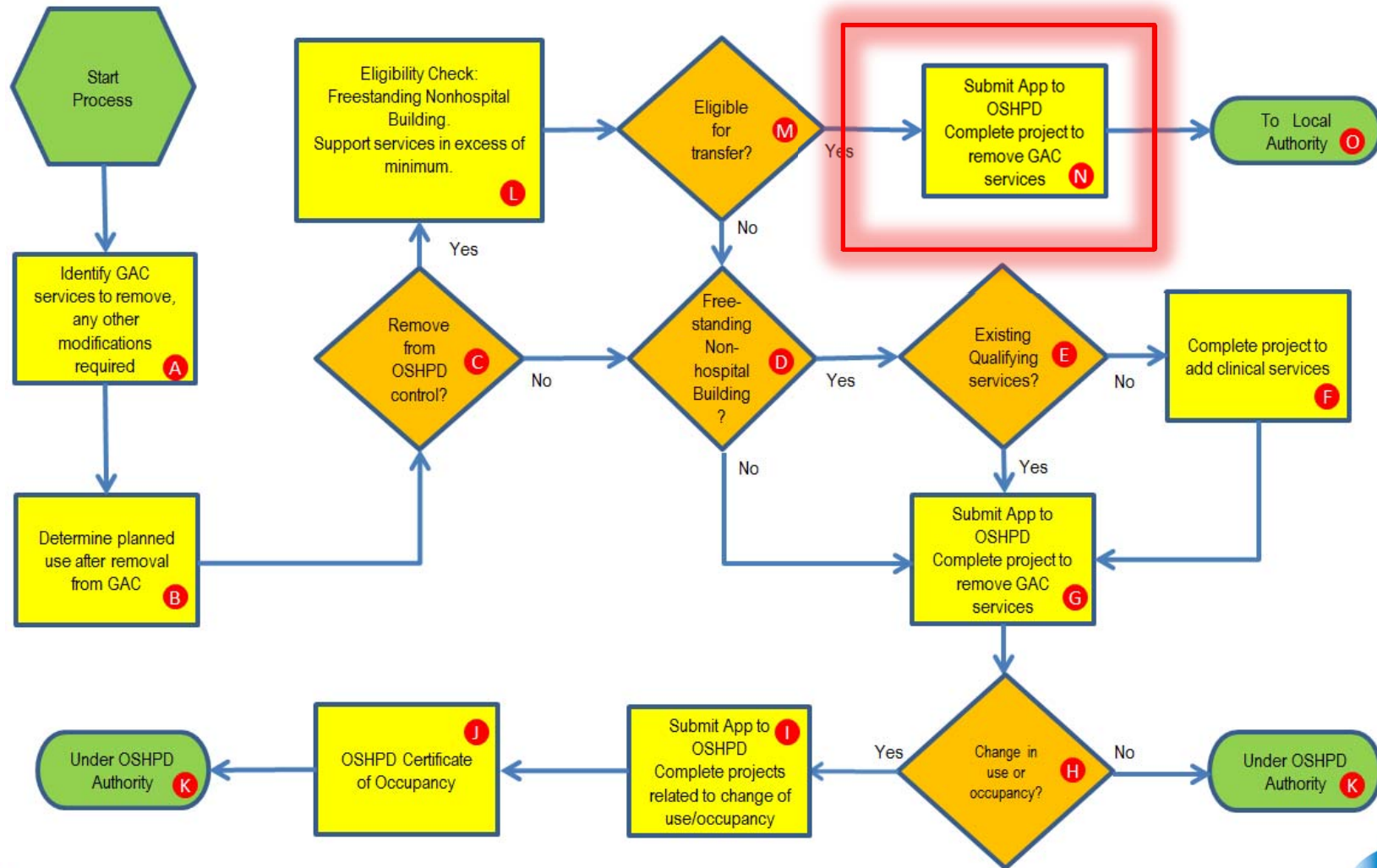

Step N: Complete Projects for Change of Use/Occupancy

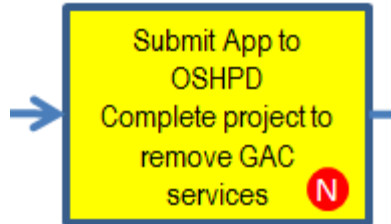

- The hospital owner submits a project to the Office to remove the *Building* from *general acute care service* and change jurisdiction to the local building authority
 - Must comply with all the criteria in Item A and Item L
 - The Owner is responsible compliance with all requirements of the local jurisdiction
 - If modifications are needed to become eligible for removal from OSHPD jurisdiction, all construction projects must be closed with compliance by OSHPD prior to the change in jurisdiction.
 - All construction work must be complete prior to submittal of the project to remove building from OSHPD jurisdiction

Removal from Acute Care Service – Detailed Process

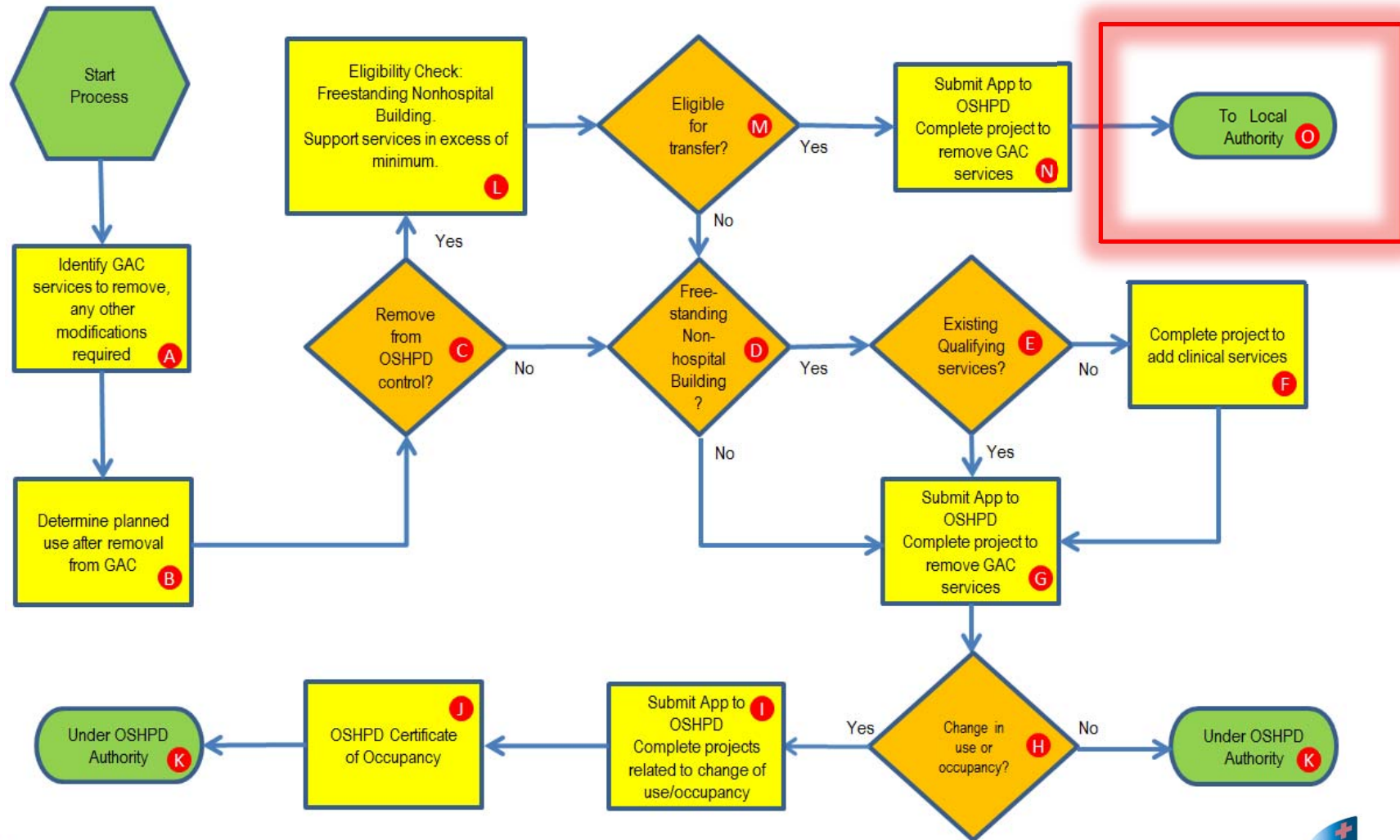

Step O: Transfer to Local Authority

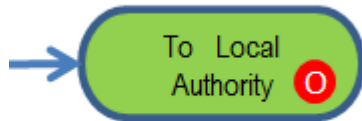

- Once the project submitted in Item N is closed with compliance, the *Freestanding Nonhospital Building* is removed from *general acute care service* and is transferred to the local authority having jurisdiction
- The Office shall notify the hospital owner and the local authority having jurisdiction of the transfer

Summary

- The most critical decision for the owner is who will have jurisdiction of the *SPC Building* after it is removed from *general acute care service*
 - Options may be limited by the proximity of the *SPC Building* to structures that remain under OSHPD jurisdiction
- Any construction required to prepare the *SPC Building* must be complete prior to the submittal of the project for removal from *general acute care service*
- The main purpose of the project for removal from *general acute care service* is to establish:
 - No acute care basic services or supplemental services are provided in a *SPC Building* removed from general acute care service
 - The hospital continues to comply with all requirements after the *SPC Building* has been removed from *general acute care service*

Removal of Acute Care Services

1	Egress from SPC 2+ through SPC 1?	No
2	Utilities through/under SPC 1 serving SPC 2+?	Yes
3	Acute care services?	No
4	Adequate fire wall/barrier or bldg separation?	Yes
5	SPC 2+ req'd patient access through SPC 1 bldg?	No
Reroute Util., then OSHPD <u>or</u> Local jurisdiction (OSHPD jurisdiction depends on occupancy, use, or function for free-standing bldg)		

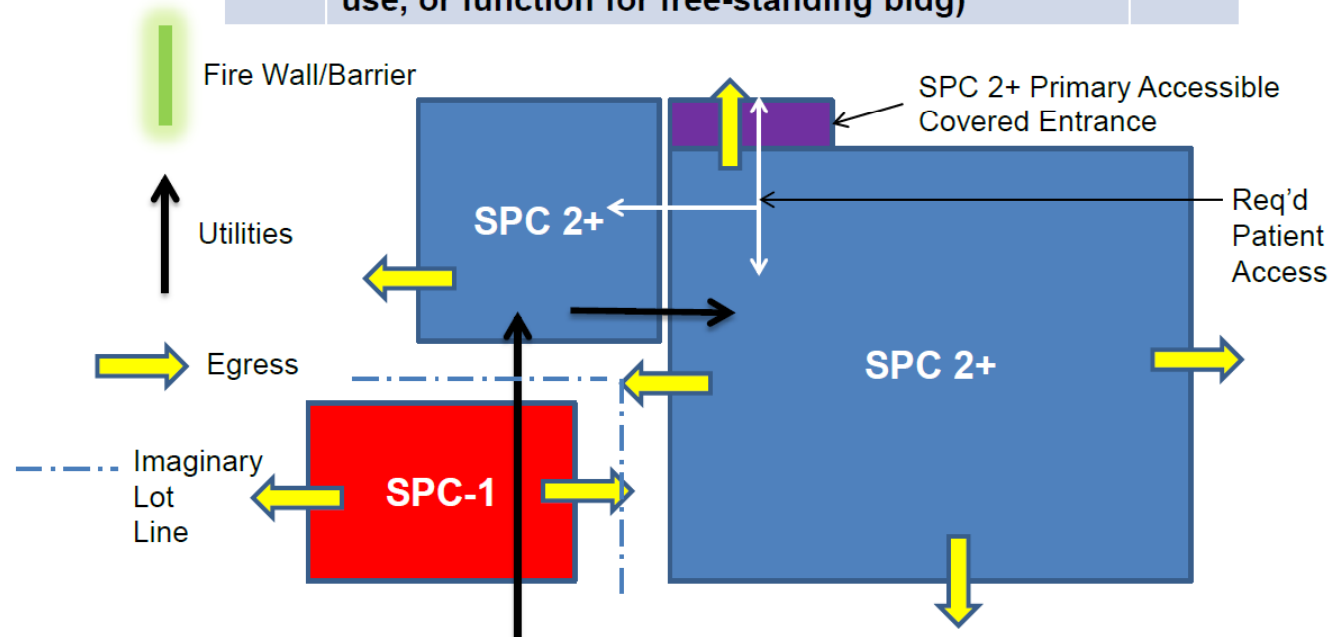

Removal of Acute Care Services

1	Egress from SPC 2+ through SPC 1?	No
2	Utilities through/under SPC 1 serving SPC 2+?	No
3	Acute care services?	No
4	Adequate fire wall/barrier or bldg separation?	No
5	SPC 2+ req'd patient access through SPC 1 bldg?	No
SPC 1 bldg must remain in OSHPD jurisdiction		

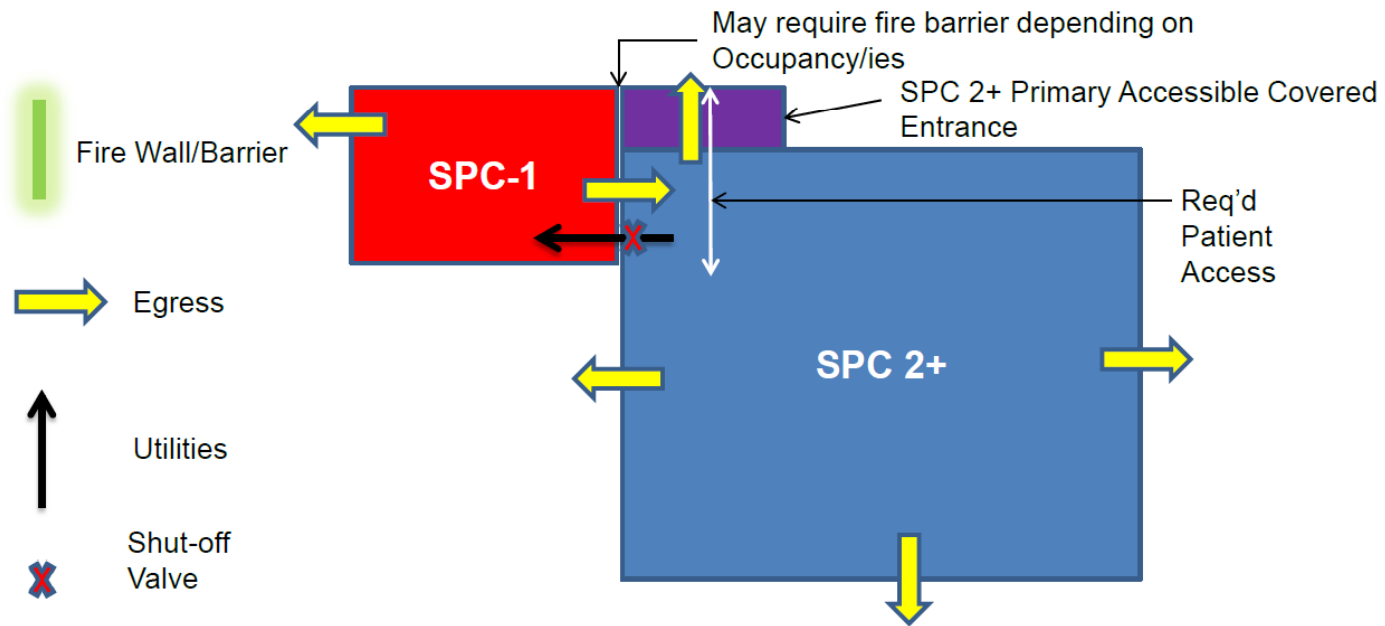

Removal of Acute Care Services

1	Egress from SPC 2+ through SPC 1?	No
2	Utilities through/under SPC 1 serving SPC 2+?	No
3	Acute care services?	No
4	Adequate fire wall/barrier or bldg separation?	Yes
5	SPC 2+ req'd patient access through SPC 1 bldg?	No
OSHPD <u>or</u> Local jurisdiction (OSHPD jurisdiction may depend on occupancy, use, or function with fire wall)		

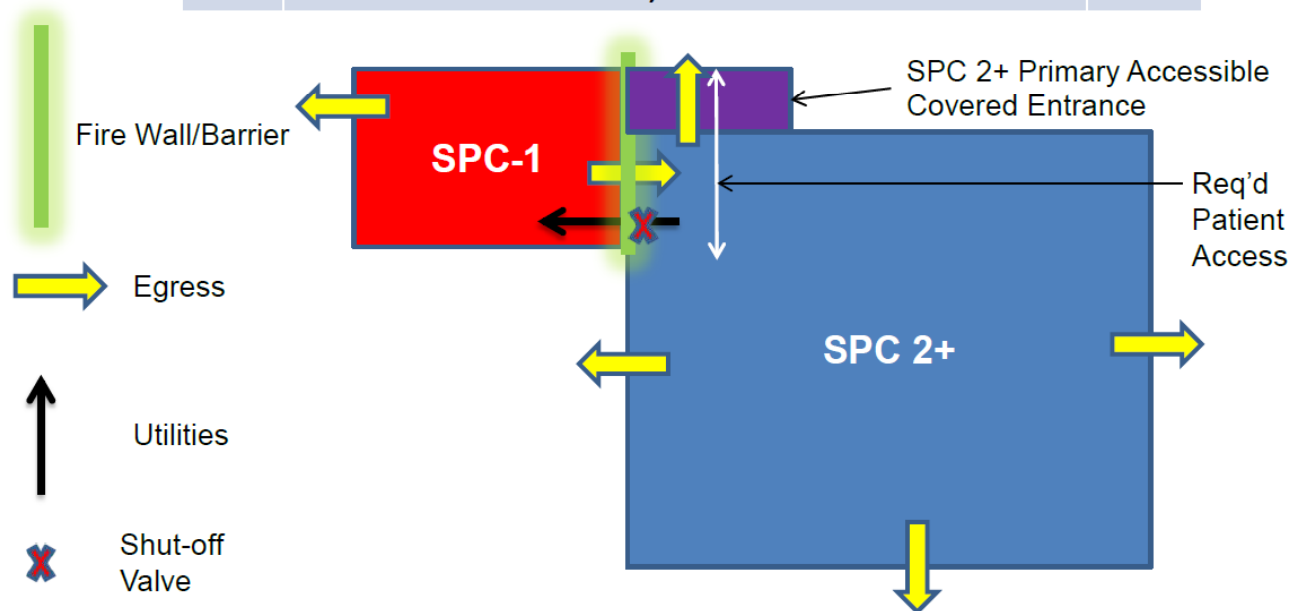

Removal of Acute Care Services

1	Egress from SPC 2+ through SPC 1?	No
2	Utilities through/under SPC 1 serving SPC 2+?	No
3	Acute care services?	No
4	Adequate fire wall/barrier or bldg separation?	No
5	SPC 2+ req'd patient access through SPC 1 bldg?	No
Must remain in OSHPD jurisdiction		

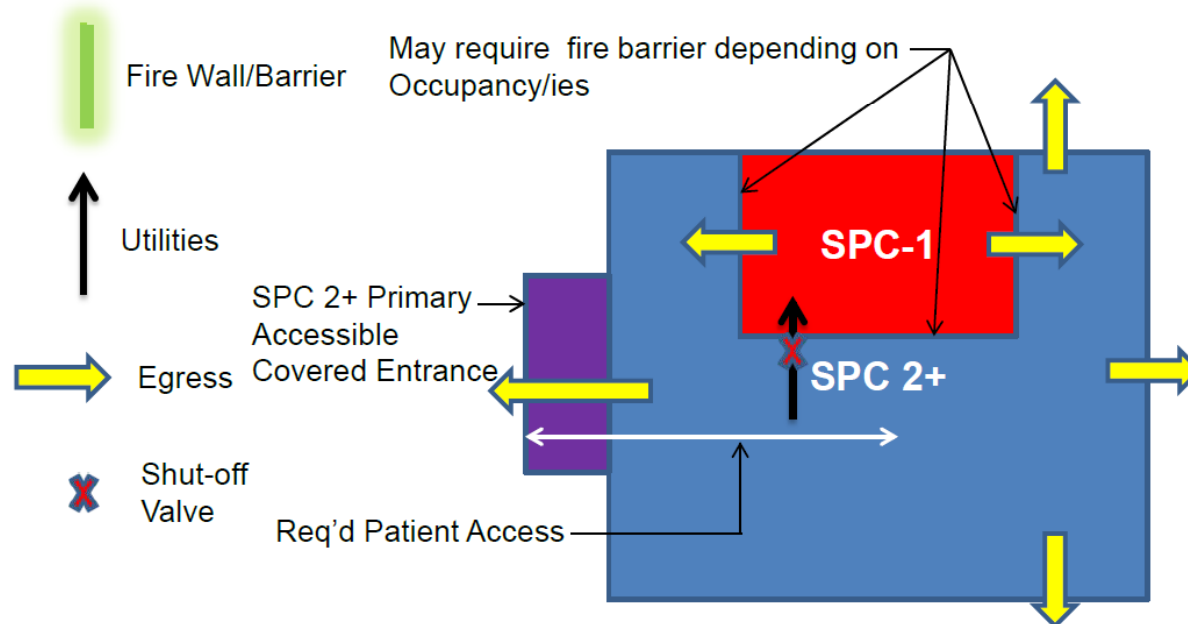

Removal of Acute Care Services

1	Egress from SPC 2+ through SPC 1?	No
2	Utilities through/under SPC 1 serving SPC 2+?	Yes
3	Acute care services?	No
4	Adequate fire wall/barrier or bldg separation?	Yes
5	SPC 2+ req'd patient access through SPC 1 bldg?	No
Reroute Util., then OSHPD <u>or</u> Local jurisdiction (OSHPD jurisdiction may depend on occupancy, use, or function with fire wall)		

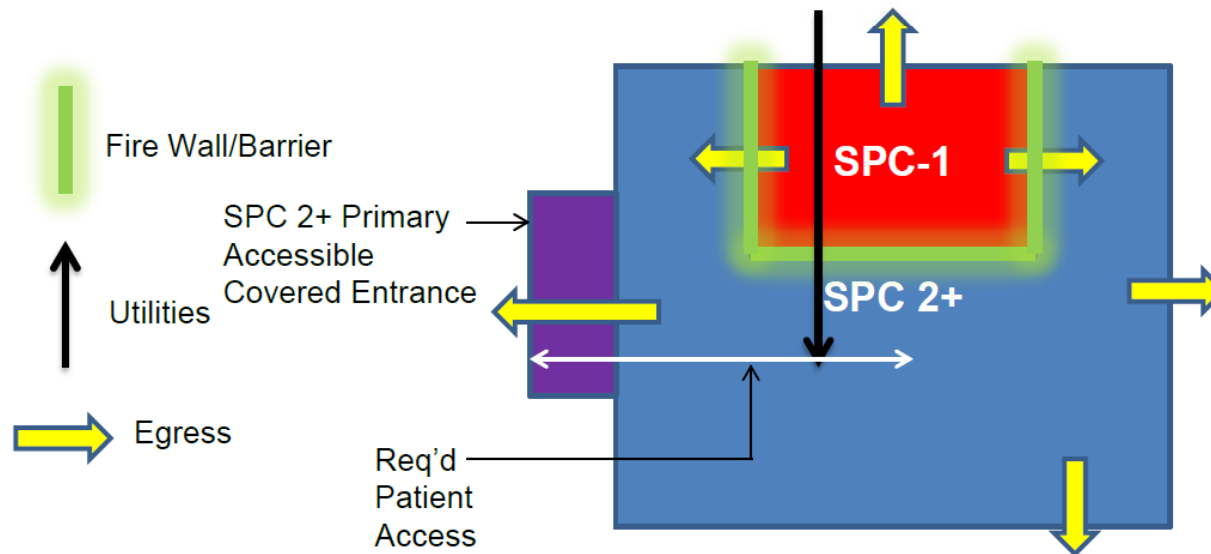

Removal of Acute Care Services

1	Egress from SPC 2+ through SPC 1	No
2	Utilities through/under SPC 1 serving SPC 2+?	Yes
3	Acute care services?	No
4	Adequate fire wall/barrier or bldg separation?	No
5	SPC 2+ req'd patient access through SPC 1 bldg?	No
Reroute Util., then OSHPD or Local jurisdiction (OSHPD jurisdiction may depend on occupancy, use, or function for free-standing bldg)		

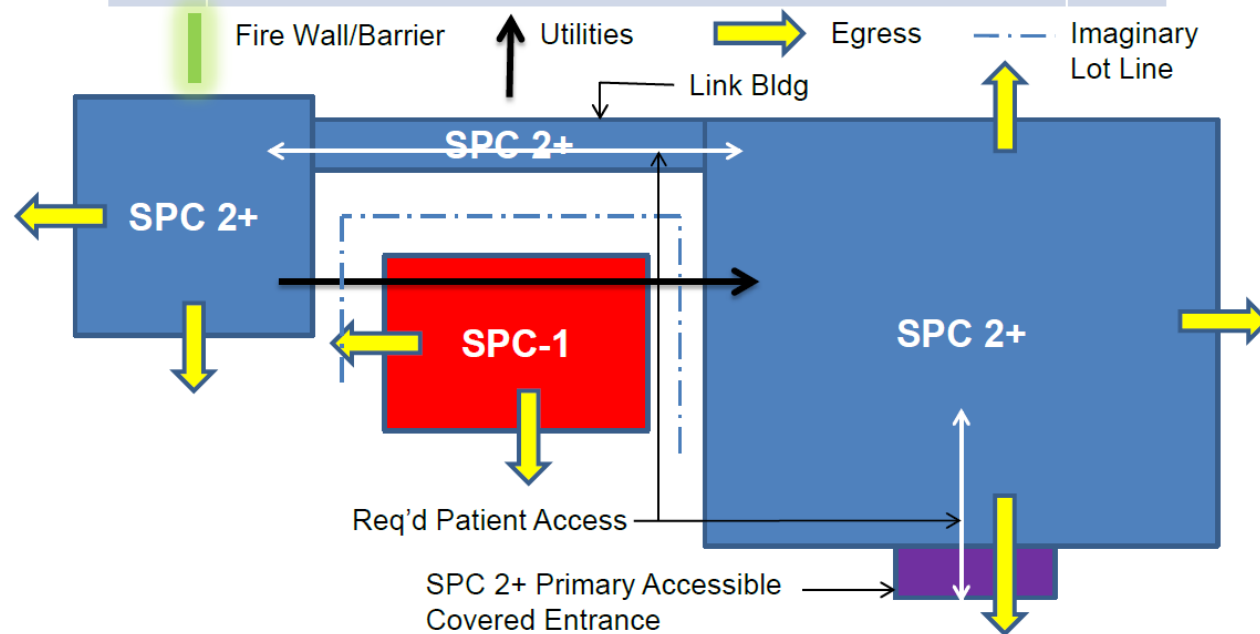

Removal of Acute Care Services

1	Egress from SPC 2+ through SPC 1?	No
2	Utilities through/under SPC 1 serving SPC 2+?	No
3	Acute care services?	No
4	Adequate fire wall/barrier or bldg separation?	No
5	SPC 2+ req'd patient access through SPC 1 bldg?	Yes
Reroute req'd patient access to not go through SPC 1 bldg, SPC 1 bldg must remain in OSHPD jurisdiction		

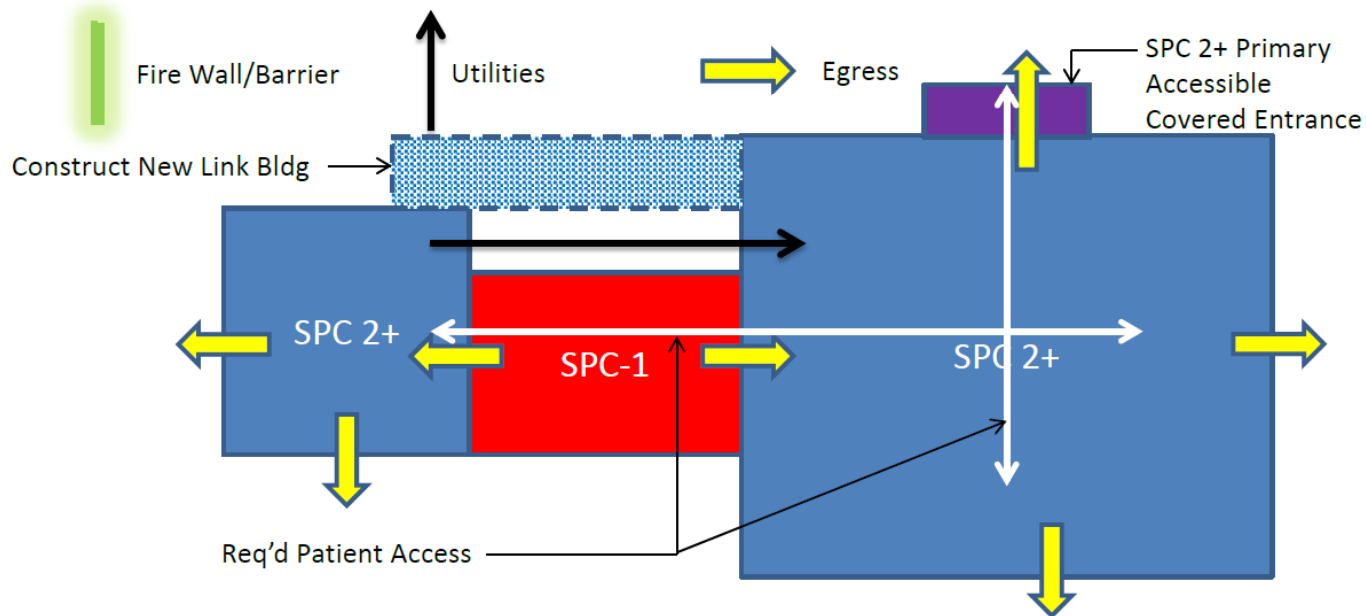

Removal of Acute Care Services

1	Egress from SPC 2+ through SPC 1?	No
2	Utilities through/under SPC 1 serving SPC 2+?	No
3	Acute care services?	No
4	Adequate fire wall/barrier or bldg separation?	Yes
5	SPC 2+ req'd patient access through SPC 1 bldg?	Yes
Reroute req'd patient access to not go through SPC 1 bldg, then OSHPD or Local jurisdiction (OSHPD jurisdiction may depend on occupancy, use, or function with fire wall)		

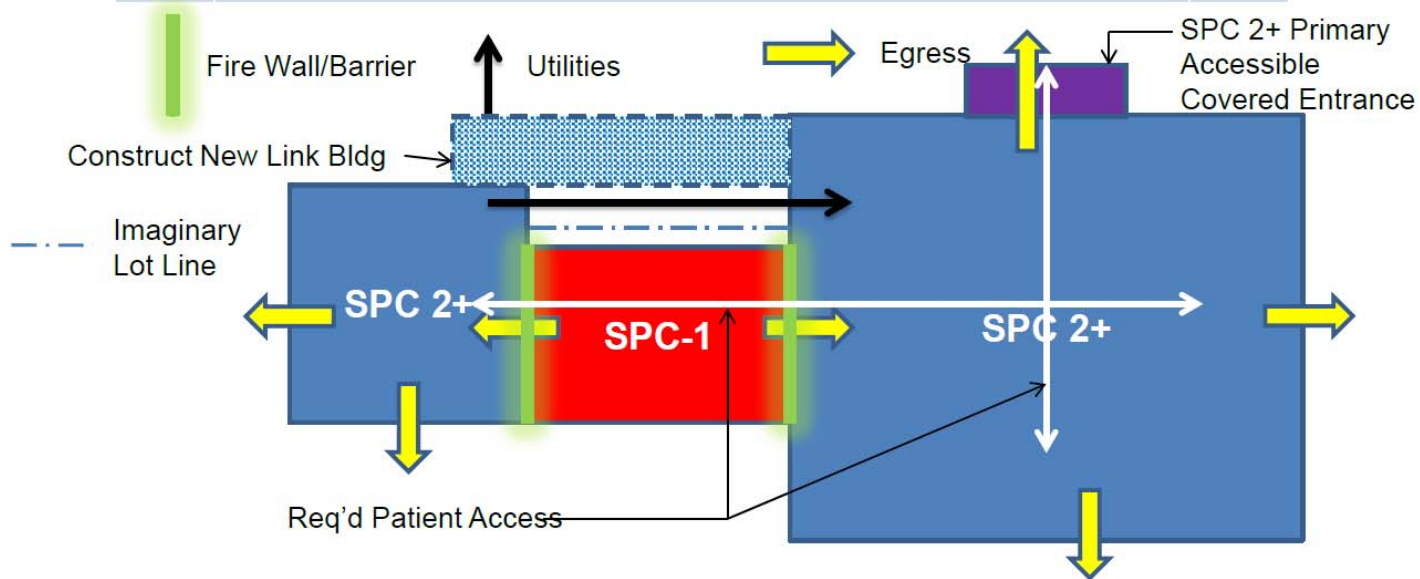

Removal of Acute Care Services

1	Egress from SPC 2+ through SPC 1?	No
2	Utilities through/under SPC 1 serving SPC 2+?	No
3	Acute care services?	No
4	Adequate fire wall/barrier or bldg separation?	Yes
5	SPC 2+ req'd patient access through SPC 1 bldg?	Yes
<p>Remove acute care services from Bldgs A & B, Reroute req'd patient access to not go through SPC 1 bldg, then OSHPD or Local jurisdiction (OSHPD jurisdiction may depend on occupancy, use, or function with fire wall)</p>		

