

“IOR Certification Code/Plans Questions” Part 1 Architectural



Architectural



Code

- Class A 10 Questions
- Class B 12 Questions



Sample Architecture Question

In Hospitals, which one of the following is not required to be included within a dressing room for a nuclear medicine space?

- a) nurse call station
- b) seat or bench
- c) mirror
- d) provisions for hanging clothes

• **How to look for the response?**



• Sample #2- The question indicates nuclear medicine space

INDEX

HOSPITALS – SUPPORT SERVICES	
Administrative space	1224.21
Central sterile supply	1224.22
Employee dressing rooms and lockers	1224.25
Housekeeping rooms	1224.26
Laundry	1224.27
Morgue and autopsy facilities	1224.24
Storage	1224.23
HOSPITALS – SUPPLEMENTAL SERVICES	
Emergency service	1224.33
Intensive care units	1224.29
Intermediate-care service space	1224.38
Nuclear medicine	1224.34
Obstetrical facilities (perinatal unit space)	1224.32
Outpatient service space	1224.39
Pediatric and adolescent unit	1224.30
Psychiatric nursing unit	1224.31
Rehabilitation therapy department	1224.35
Renal dialysis service space (acute and chronic)	1224.36
Respiratory therapy service space	1224.37
Skilled nursing service space	1224.40
Social service space	1224.41
Supplemental surgery services	1224.28
HOTEL (or MOTEL) (definition) 202	
HURRICANE-PRONE REGIONS (see WIND LOADS) 202	
HURRICANE SHELTER (see STORM SHELTER)	
HURRICANE SHUTTERS	1609.2
HYDROGEN FUEL GAS ROOMS	421, Table 509
HYPERBARIC FACILITIES	425

AT THE CHAPTER 1224

INTERIOR ENVIRONMENT

1224.33.4.5 On-call room(s). Provisions shall be made to accommodate on-call sleeping room(s) for physicians and/or medical staff within the Emergency Department.

1224.33.4.6 Police and press room. Provisions shall be made to accommodate police briefing/debriefing and press releases. This may be located outside the Emergency Department.

1224.33.5 Other space considerations.

1224.33.5.1 Observation units. Observation rooms for the monitoring of patients up to 24 hours may be provided as a distinct unit within the emergency department. If provided the unit shall have the following:

1. Handwashing stations shall be provided in each patient room and for each four treatment stations, and for each major fraction thereof. These shall be uniformly distributed to provide equal access from each patient station. Handwashing stations shall be directly accessible to nurse stations and patient care areas.
2. Each patient station shall have a minimum of 120 square feet (11.15 m²) of clear floor area including space at each bedside for visitors and provision for visual privacy from casual observation by other patients and visitors.
3. One toilet room shall be provided for each six treatment stations and for each major fraction thereof.
4. An administrative center/nurse station, in compliance with Section 1224.4.4.2, positioned to allow staff to observe each patient care station or room.
5. A nourishment area in compliance with Section 1224.4.4.5.

1224.34 NUCLEAR MEDICINE

1224.34.1 General. If nuclear medicine is provided, the following shall be provided:

1224.34.1.1 Radiation protection. A certified physicist shall specify the type, location and amount of radiation protection to be installed in accordance with final approved department layout and equipment selection. Radiation protection requirements shall be incorporated into the construction documents and comply with Chapter 31C and the requirements of California Radiation Control Regulations, California Code of Regulations, Title 17, Division 1, Chapter 5, and Subchapter 4.

1224.34.1.2 Nuclear medicine room. Shall be sized to accommodate the equipment and a gurney.

When provided, the following facilities shall meet the requirements below:

1224.34.1.2.1 Scintigraphy (Gamma Camera) Facilities. Shall include the following:

1. Scanner room. The scanner room shall provide a minimum clearance of 4 feet (1218 mm) at each side and the foot of the table.
2. Handwashing stations shall be provided throughout the gamma camera suite at locations of patient contact and at locations where radiopharmaceutical materials are handled, prepared, or disposed of.

1224.34.1.2.2 Positron Emission Tomography (PET). Shall include the following:

1. Scanner room shall provide a minimum clearance of 4 feet (1218 mm) at each side and the foot of the table. Additional space shall be provided when PET is combined with CT, and include compliance with Section 1224.18.3 and shielding requirements in Section 1224.34.1.1.
2. Cyclotron room. Where radiopharmaceuticals are prepared on-site, a cyclotron shall be provided. Cyclotron facilities shall be located in access-restricted areas. Shielding requirements for cyclotron facilities shall comply with Section 1224.34.1.1.

3. Control room. A control room shall be provided with a full direct view of the patient in the PET scanner.

4. Patient uptake/cool-down room. A shielded room with access to a dedicated patient toilet, to accommodate radioactive waste, and lavatory shall be provided.

5. Handwashing stations shall be provided throughout the PET suite at locations of patient contact and at locations where radiopharmaceutical materials are handled, prepared, or disposed of.

6. Pre-procedure patient care and recovery area shall be provided to accommodate at least two stretchers. This area shall comply with Section 1224.34.2.6.

7. Computer equipment room shall be provided in support of the equipment provided.

8. Contaminated (hot) soiled holding shall be provided and operationally integrated to minimize incidental exposure to ionizing radiation.

1224.34.1.2.3 Single-Photon Emission Computed Tomography (SPECT) Facilities. When provided shall include the following:

1. Scanner room. Scanner room shall provide a minimum clearance of 4 feet (1218 mm) at each side and the foot of the table.

INTERIOR ENVIRONMENT

2. Control room. A control room shall be provided with a full direct view of the patient in the SPECT scanner.

3. Computer equipment room shall be provided in support of the equipment provided.

4. Handwashing stations shall be provided throughout the SPECT suite at locations of patient contact and at locations where radiopharmaceutical materials are handled, prepared, or disposed.

1224.34.1.3 Radiopharmacy. If radiopharmaceutical preparation is performed, an area adequate to house a radiopharmacy shall be provided with appropriate shielding. This area shall include adequate space for storage of radionuclides, chemicals for preparation, dose calibrators, and record keeping. If preprepared materials are used, storage and calculation area may be considerably smaller than that for on-site preparation. Space shall provide adequately for dose calibration, quality assurance, and record keeping. The area may still require shielding from other portions of the facilities.

1224.34.2 Support areas for nuclear medicine services. Nuclear medicine area when operated separately from the imaging department shall provide the following:

1224.34.2.1 Entrance. Space shall be adequate to permit entry of gurneys, beds, and able to accommodate imaging equipment, electronic consoles, and if present, computer terminals.

1224.34.2.2 Cleanup. Provisions for cleanup shall be located within the service space and be readily accessible. They shall include a service sink or floor receptacle as well as storage space for equipment and supplies.

1224.34.2.3 Consultation. A consultation area may be provided.

1224.34.2.4 Waiting. Waiting areas shall be provided out of traffic, under staff control. If the department is routinely used for outpatients and inpatients at the same time, separate waiting areas shall be provided with screening or visual privacy between the waiting areas.

1224.34.2.5 Dose administration area. Provide a dose administration area that is immediately accessible to the preparation area. Since as much as several hours may elapse for the dose to take effect, the area shall provide for visual privacy from other areas.

1224.34.2.6 Pre-procedure/holding area. A pre-procedure/holding area for patients on gurneys or beds shall be provided out of traffic and under control of staff and may be combined with the dose administration area with visual privacy between the areas.

1224.34.2.7 Patient dressing rooms. Patient dressing rooms shall be immediately accessible to the waiting area and procedure rooms. Each dressing room shall include a seat or bench, a mirror, and provisions for hanging patients' clothing and for securing valuables.

In Hospitals, which one of the following is not required to be included within a dressing room for a nuclear medicine space?

1224.34.2.7 Patient dressing rooms. Patient dressing rooms shall be immediately accessible to the waiting area and procedure rooms. Each dressing room shall include a seat or bench, a mirror, and provisions for hanging patients' clothing and for securing valuables.



Response:

- a) nurse call station
- b) seat or bench
- c) mirror
- d) provisions for hanging clothes



Plan

- Class A 13 Questions
- Class B 7 Questions





Architectural Plan Questions

- Let's analyze the questions with the correct responses...
- How to read/interpret the question
- How to arrive to a response (sometimes it is easy, sometimes it is not easy)
- Remember: Plans are not perfect. And this is why Request For Information (RFI) exist during construction

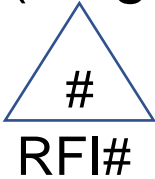
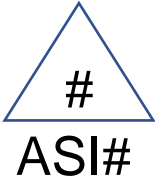

Table of contents

- Drawing Content (Original set, RFI, ASI, ACD)

- delta symbol RFI  ASI  ACD 

- Depending on the size and complexity of the project
- the information provided on the fire and life safety drawings **should provide a clear description of how the project complies with the various provisions of the CBC.** Some of the general information for the project may also appear on the drawing title sheet.
- Also, much of the specific information will be contained in the body of drawing details and schedules.



Table of contents

DESIGNATOR	NAME
	Cover Sheet
G	General
H	Hazardous Materials
V	Survey / Mapping
B	Geotechnical
C	Civil
L	Landscape
S	Structural
A	Architectural
I	Interiors
Q	Equipment
F	Fire Protection
P	Plumbing

D	Process
M	Mechanical
E	Electrical
W	Distributed Energy
T	Telecommunications
R	Resource
X	Other Disciplines
Z	Contractor / Shop Drawings
O	Operations



Sheet Types

DESIGNATOR	NAME
0	General: Symbol legend, abbreviations, general notes
1	Plans
2	Elevations
3	Sections
4	Large Scale Drawings: plans, elevations, sections (NOT details)
5	Details
6	Schedules and Diagrams
7	User Defined
8	User Defined
9	3D drawings: isometric, perspective, photos



MASTER DRAWING INDEX:

C-0 COVER SHEET
 G1.01 GENERAL NOTES/CODE ANALYSIS/LEGENDS
 G1.02 U.L. ASSEMBLIES
 G1.03 U.L. ASSEMBLIES

C-0 COVER SHEET
 G1.01 GENERAL NOTES/CODE ANALYSIS/LEGENDS
 G1.02 U.L. ASSEMBLIES
 G1.03 U.L. ASSEMBLIES

ARCHITECTURAL PLANS

A0.01 ARCHITECTURAL SITE PLAN
 A0.51 SITE DETAILS
 L51.01 LIFE SAFETY PLAN - 1ST FLOOR, OVERALL
 L51.01A LIFE SAFETY PLAN - 1ST FLOOR, PART A
 L51.01B LIFE SAFETY PLAN - 1ST FLOOR, PART B
 L51.02 LIFE SAFETY PLAN - 2ND FLOOR, OVERALL
 L51.02A LIFE SAFETY PLAN - 2ND FLOOR, PART A
 L51.02B LIFE SAFETY PLAN - 2ND FLOOR, PART B
 A1.00A OVERALL FLOOR PLAN - 1ST FLOOR
 A1.00B OVERALL FLOOR PLAN - 2ND FLOOR
 A1.01A DIMENSION PLAN - 1ST FLOOR, PART A
 A1.01B DIMENSION PLAN - 1ST FLOOR, PART B
 A1.02A DIMENSION PLAN - 2ND FLOOR, PART A
 A1.02B DIMENSION PLAN - 2ND FLOOR, PART B
 A1.51A NOTED PLAN - 1ST FLOOR, PART A
 A1.51B NOTED PLAN - 1ST FLOOR, PART B
 A1.52A NOTED PLAN - 2ND FLOOR, PART A
 A1.52B NOTED PLAN - 2ND FLOOR, PART B
 A1.81A EQUIPMENT PLAN - 1ST FLOOR, PART A
 A1.81B EQUIPMENT PLAN - 1ST FLOOR, PART B
 A1.82A EQUIPMENT PLAN - 2ND FLOOR, PART A
 A1.82B EQUIPMENT PLAN - 2ND FLOOR, PART B
 A2.01 ENLARGED PLANS & ELEVATIONS
 A2.02 ENLARGED PLANS & ELEVATIONS
 A2.21 ENLARGED PLANS: TOILETS
 A2.22 ENLARGED PLANS & ELEVATIONS
 A2.61 VERTICAL TRANSPORT: STAIRWELLS
 A2.71 VERTICAL TRANSPORT: ELEVATORS
 A3.01A CEILING PLAN - 1ST FLOOR, PART A
 A3.01B CEILING PLAN - 1ST FLOOR, PART B
 A3.02A CEILING PLAN - 2ND FLOOR, PART A
 A3.02B CEILING PLAN - 2ND FLOOR, PART B
 A3.51 CEILING DETAILS
 A4.01 ROOF PLAN
 A4.51 ROOF DETAILS
 A5.01 EXTERIOR ELEVATIONS
 A5.02 EXTERIOR ELEVATIONS - ENLARGED
 A5.03 EXTERIOR ELEVATIONS - ENLARGED
 A6.00 BUILDING SECTION
 A6.20 INTERIOR WALL TYPES/DETAILS
 A6.21 WALL SECTIONS
 A6.22 WALL SECTIONS
 A6.23 WALL SECTIONS
 A6.24 WALL SECTIONS
 A6.25 WALL SECTIONS
 A6.26 WALL SECTIONS
 A6.51 GENERAL DETAILS
 A6.52 GENERAL DETAILS
 A6.53 GENERAL DETAILS
 A6.54 GENERAL DETAILS
 A6.55 GENERAL DETAILS
 A6.56 GENERAL DETAILS
 A7.01 DOOR SCHEDULE
 A7.02 WINDOW ELEVATIONS
 A7.51 DOOR DETAILS
 A7.52 WINDOW DETAILS
 A8.01 CASEWORK ELEVATIONS
 A8.02 CASEWORK ELEVATIONS
 A8.03 CASEWORK ELEVATIONS
 A8.51 CASEWORK DETAILS
 A8.52 CASEWORK DETAILS
 A8.53 CASEWORK DETAILS
 F1.01A FURNISHING PLAN - 1ST FLOOR, PART A
 F1.01B FURNISHING PLAN - 1ST FLOOR, PART B
 F1.02A FURNISHING PLAN - 2ND FLOOR, PART A
 F1.02B FURNISHING PLAN - 2ND FLOOR, PART B
 F2.01A PATTERN PLAN - 1ST FLOOR, PART A
 F2.01B PATTERN PLAN - 1ST FLOOR, PART B
 F2.02A PATTERN PLAN - 2ND FLOOR, PART A
 F2.02B PATTERN PLAN - 2ND FLOOR, PART B

KITCHEN PLANS

FS1.1 KITCHEN EQUIPMENT
 FS1.2 KITCHEN PLUMBING
 FS1.3 KITCHEN ELECTRICAL
 FS1.4 KITCHEN VENTILATION

STRUCTURAL PLANS

S2.0 GENERAL NOTES
 S1.1 FOUNDATION PLAN: PART A
 S1.2 FOUNDATION PLAN: PART B
 S2.1 FOUNDATION SECTIONS & DETAILS
 S2.2 FOUNDATION SECTIONS & DETAILS
 S2.3 FOUNDATION SECTIONS & DETAILS
 S3.1 SECOND FLOOR FRAMING PLAN: PART A
 S3.2 SECOND FLOOR FRAMING PLAN: PART B
 S3.3 ROOF FRAMING PLAN: PART A
 S3.4 ROOF FRAMING PLAN: PART B
 S4.1 FRAMING SECTIONS & DETAILS
 S4.2 FRAMING SECTIONS & DETAILS
 S4.3 FRAMING SECTIONS & DETAILS
 S4.4 EXTERIOR STUD WALL ELEVATIONS & DETAILS
 S5.1 CRACK/COLUMN SCHEDULE & DETAILS
 S5.2 FRAME ELEVATIONS
 S5.3 FRAME ELEVATIONS
 S5.8 BEAM/COLUMN CONNECTIONS

MECHANICAL PLANS

M0.01 HVAC SCHEDULES
 M0.02 HVAC SCHEDULES
 M0.03 HVAC SCHEDULES
 M0.04 HVAC VENTILATION TABLE
 M0.05 HVAC VENTILATION TABLE
 M0.06 HVAC VENTILATION TABLE
 M0.07 HVAC VENTILATION TABLE
 M2.01 HVAC NEW CONSTRUCTION-1st FLOOR: PART A
 M2.02 HVAC PIPING-1st FLOOR: PART A
 M2.03 HVAC NEW CONSTRUCTION-1st FLOOR: PART B
 M2.04 HVAC PIPING-1st FLOOR: PART B
 M2.05 ROOF PLUMB PART A
 M2.06 ROOF PLUMB PART B
 M2.07 LARGE SCALE MECHANICAL ROOM
 M2.08 LARGE SCALE SECTIONS
 M3.01 HVAC CONTROLS
 M3.02 HVAC CONTROLS
 M4.01 HVAC DETAILS
 M4.02 HVAC DETAILS
 M5.01 HVAC DETAILS
 M5.02 HVAC DETAILS
 M6.01 HVAC NEW CONSTRUCTION-2nd FLOOR: PART A
 M6.02 HVAC PIPING-2nd FLOOR: PART A
 M6.03 HVAC NEW CONSTRUCTION-2nd FLOOR: PART B
 M6.04 HVAC PIPING-2nd FLOOR: PART B

PLUMBING PLANS

P0.01 PLUMBING SCHEDULES
 P0.02 SITE PLAN: PLUMBING
 P1.01 UNDERGROUND PLUMBING-1st FLOOR: PART A
 P1.02 UNDERGROUND PLUMBING-1st FLOOR: PART B
 P1.01 PLUMBING-1st FLOOR: PART A
 P1.02 PLUMBING-1st FLOOR: PART B
 P1.03 PLUMBING-2nd FLOOR: PART A
 P1.04 PLUMBING-2nd FLOOR: PART B
 P1.05 PLUMBING-ROOF: PART A
 P1.06 PLUMBING-ROOF: PART B
 P2.01 MEDICAL GAS-1st FLOOR: PART A
 P2.02 MEDICAL GAS-1st FLOOR: PART B
 P2.03 MEDICAL GAS-2nd FLOOR: PART A
 P2.04 MEDICAL GAS-2nd FLOOR: PART B
 P3.01 LARGE SCALE PLUMBING: MECHANICAL ROOM
 P3.02 LARGE SCALE PLUMBING: KITCHEN
 P4.01 PLUMBING RISERS
 P5.01 PLUMBING DETAILS
 P5.02 PLUMBING DETAILS

ELECTRICAL PLANS

E0.01 ELECTRICAL INDEX & SCHEDULES
 E0.02 ELECTRICAL LEGENDS
 E0.03 ELECTRICAL EQUIPMENT CONNECTION SCHEDULES
 E0.04 ELECTRICAL EQUIPMENT SCHEDULES
 E1.01 LIGHTING-1st FLOOR: PART A
 E2.01 LIGHTING-1st FLOOR: PART B
 E2.02 LIGHTING-2nd FLOOR: PART A
 E2.03 LIGHTING-2nd FLOOR: PART B
 E2.04 LIGHTING-2nd FLOOR: PART B
 E3.01 POWER-1st FLOOR: PART A
 E3.02 POWER-1st FLOOR: PART B
 E3.03 POWER-2nd FLOOR: PART A
 E3.04 POWER-2nd FLOOR: PART B
 E4.01 SYSTEMS-1st FLOOR: PART A
 E4.02 SYSTEMS-1st FLOOR: PART B
 E4.03 SYSTEMS-2nd FLOOR: PART A
 E4.04 SYSTEMS-2nd FLOOR: PART B
 E5.01 ELECTRICAL-ROOF: PART A
 E5.02 ELECTRICAL-ROOF: PART B
 E6.01 LARGE SCALE ELECTRICAL
 E6.02 LARGE SCALE ELECTRICAL
 E7.01 ELECTRICAL POWER DISTRIBUTION: RISER
 E7.02 ELECTRICAL POWER DISTRIBUTION: NORMAL ONE LINE DIAGRAM
 E7.03 ELECTRICAL POWER DISTRIBUTION: ESSENTIAL ONE LINE DIAGRAM
 E7.04 ELECTRICAL POWER DISTRIBUTION: ESSENTIAL ONE LINE DIAGRAM
 E8.01 TELECOMMUNICATION DETAILS
 E9.01 ELECTRICAL DETAILS
 E9.02 ELECTRICAL PANELBOARD SCHEDULES: NORMAL SYSTEM
 E9.03 ELECTRICAL PANELBOARD SCHEDULES: ESSENTIAL SYSTEM

FIRE SPRINKLER PLAN

FP-1 COVER SHEET
 FP-2 FIRST FLOOR PART A PIPING PLAN
 FP-3 FIRST FLOOR PART B PIPING PLAN
 FP-4 FIRST FLOOR PART A RCP
 FP-5 FIRST FLOOR PART B RCP
 FP-6 SECOND FLOOR FIRE SPRINKLER PIPING PLAN
 FP-7 SECOND FLOOR RCP

SEISMIC RESTRAINT

SR A1 SEISMIC RESTRAINT ARCHITECTURAL DETAIL
 SR A2 SEISMIC RESTRAINT ARCHITECTURAL DETAIL
 SR A3 SEISMIC RESTRAINT ARCHITECTURAL DETAIL
 SR A4 SEISMIC RESTRAINT ARCHITECTURAL DETAIL
 SR A5 SEISMIC RESTRAINT ARCHITECTURAL DETAIL
 SR A6 SEISMIC RESTRAINT ARCHITECTURAL DETAIL
 SR A7 SEISMIC RESTRAINT ARCHITECTURAL DETAIL
 SR A8 SEISMIC RESTRAINT ARCHITECTURAL DETAIL
 SR A9 SEISMIC RESTRAINT ARCHITECTURAL DETAIL
 SR A10 SEISMIC RESTRAINT ARCHITECTURAL DETAIL
 SR A11 SEISMIC RESTRAINT ARCHITECTURAL DETAIL
 SR A12 SEISMIC RESTRAINT ARCHITECTURAL DETAIL
 SR G1 SEISMIC RESTRAINT GENERAL DETAIL
 SR M1 SEISMIC RESTRAINT MECHANICAL DETAIL
 SR M2 SEISMIC RESTRAINT MECHANICAL DETAIL
 SR M3 SEISMIC RESTRAINT MECHANICAL DETAIL
 SR M4 SEISMIC RESTRAINT MECHANICAL DETAIL
 SR M5 SEISMIC RESTRAINT MECHANICAL DETAIL
 SR E1 SEISMIC RESTRAINT ELECTRICAL DETAIL
 SR E2 SEISMIC RESTRAINT ELECTRICAL DETAIL
 SR E3 SEISMIC RESTRAINT ELECTRICAL DETAIL
 SR P1 SEISMIC RESTRAINT PLUMBING DETAIL

MASTER DRAWING INDEX:

ARCHITECTURAL PLANS	
AD.01	ARCHITECTURAL SITE PLAN
AD.51	SITE DETAILS
LS1.01	LIFE SAFETY PLAN - 1ST FLOOR, OVERALL
LS1.01A	LIFE SAFETY PLAN - 1ST FLOOR, PART A
LS1.01B	LIFE SAFETY PLAN - 1ST FLOOR, PART B
LS1.02	LIFE SAFETY PLAN - 2ND FLOOR, OVERALL
LS1.02A	LIFE SAFETY PLAN - 2ND FLOOR, PART A
LS1.02B	LIFE SAFETY PLAN - 2ND FLOOR, PART B
A1.00A	OVERALL FLOOR PLAN - 1ST FLOOR
A1.00B	OVERALL FLOOR PLAN - 2ND FLOOR
A1.01A	DIMENSION PLAN - 1ST FLOOR, PART A
A1.01B	DIMENSION PLAN - 1ST FLOOR, PART B
A1.02A	DIMENSION PLAN - 2ND FLOOR, PART A
A1.02B	DIMENSION PLAN - 2ND FLOOR, PART B
A1.51A	NOTED PLAN - 1ST FLOOR, PART A
A1.51B	NOTED PLAN - 1ST FLOOR, PART B
A1.52A	NOTED PLAN - 2ND FLOOR, PART A
A1.52B	NOTED PLAN - 2ND FLOOR, PART B
A1.81A	EQUIPMENT PLAN - 1ST FLOOR, PART A
A1.81B	EQUIPMENT PLAN - 1ST FLOOR, PART B
A1.82A	EQUIPMENT PLAN - 2ND FLOOR, PART A
A1.82B	EQUIPMENT PLAN - 2ND FLOOR, PART B
A2.01	ENLARGED PLANS & ELEVATIONS
A2.02	ENLARGED PLANS & ELEVATIONS
A2.21	ENLARGED PLANS: TOILETS
A2.22	ENLARGED PLANS & ELEVATIONS
A2.61	VERTICAL TRANSPORT: STAIRWELLS
A2.71	VERTICAL TRANSPORT: ELEVATORS
A3.01A	CEILING PLAN - 1ST FLOOR, PART A
A3.01B	CEILING PLAN - 1ST FLOOR, PART B
A3.02A	CEILING PLAN - 2ND FLOOR, PART A
A3.02B	CEILING PLAN - 2ND FLOOR, PART B
A3.51	CEILING DETAILS
A4.01	ROOF PLAN
A4.51	ROOF DETAILS
A5.01	EXTERIOR ELEVATIONS
A5.02	EXTERIOR ELEVATIONS - ENLARGED
A5.03	EXTERIOR ELEVATIONS - ENLARGED
A6.00	BUILDING SECTION
A8.20	INTERIOR WALL TYPES/DETAILS
A8.21	WALL SECTIONS
A8.22	WALL SECTIONS
A8.23	WALL SECTIONS
A8.24	WALL SECTIONS
A8.25	WALL SECTIONS
A8.26	WALL SECTIONS
A8.27	WALL SECTIONS
A8.51	GENERAL DETAILS
A8.52	GENERAL DETAILS
A8.53	GENERAL DETAILS
A8.54	GENERAL DETAILS
A8.55	GENERAL DETAILS
A8.56	GENERAL DETAILS
A7.01	DOOR SCHEDULE
A7.02	WINDOW ELEVATIONS
A7.51	DOOR DETAILS
A7.52	WINDOW DETAILS
A8.01	CASEWORK ELEVATIONS
A8.02	CASEWORK ELEVATIONS
A8.03	CASEWORK ELEVATIONS
A8.51	CASEWORK DETAILS
A8.52	CASEWORK DETAILS
A8.53	CASEWORK DETAILS
F1.01A	FURNISHING PLAN - 1ST FLOOR, PART A
F1.01B	FURNISHING PLAN - 1ST FLOOR, PART B
F1.02A	FURNISHING PLAN - 2ND FLOOR, PART A
F1.02B	FURNISHING PLAN - 2ND FLOOR, PART B
F2.01A	PATTERN PLAN - 1ST FLOOR, PART A
F2.01B	PATTERN PLAN - 1ST FLOOR, PART B
F2.02A	PATTERN PLAN - 2ND FLOOR, PART A
F2.02B	PATTERN PLAN - 2ND FLOOR, PART B

ARCHITECTURAL PLANS	
AD.01	ARCHITECTURAL SITE PLAN
AD.51	SITE DETAILS
LS1.01	LIFE SAFETY PLAN - 1ST FLOOR, OVERALL
LS1.01A	LIFE SAFETY PLAN - 1ST FLOOR, PART A
LS1.01B	LIFE SAFETY PLAN - 1ST FLOOR, PART B
LS1.02	LIFE SAFETY PLAN - 2ND FLOOR, OVERALL
LS1.02A	LIFE SAFETY PLAN - 2ND FLOOR, PART A
LS1.02B	LIFE SAFETY PLAN - 2ND FLOOR, PART B
A1.00A	OVERALL FLOOR PLAN - 1ST FLOOR
A1.00B	OVERALL FLOOR PLAN - 2ND FLOOR
A1.01A	DIMENSION PLAN - 1ST FLOOR, PART A
A1.01B	DIMENSION PLAN - 1ST FLOOR, PART B
A1.02A	DIMENSION PLAN - 2ND FLOOR, PART A
A1.02B	DIMENSION PLAN - 2ND FLOOR, PART B
A1.51A	NOTED PLAN - 1ST FLOOR, PART A
A1.51B	NOTED PLAN - 1ST FLOOR, PART B
A1.52A	NOTED PLAN - 2ND FLOOR, PART A
A1.52B	NOTED PLAN - 2ND FLOOR, PART B
A1.81A	EQUIPMENT PLAN - 1ST FLOOR, PART A
A1.81B	EQUIPMENT PLAN - 1ST FLOOR, PART B
A1.82A	EQUIPMENT PLAN - 2ND FLOOR, PART A
A1.82B	EQUIPMENT PLAN - 2ND FLOOR, PART B
A2.01	ENLARGED PLANS & ELEVATIONS
A2.02	ENLARGED PLANS & ELEVATIONS
A2.21	ENLARGED PLANS: TOILETS
A2.22	ENLARGED PLANS & ELEVATIONS
A2.61	VERTICAL TRANSPORT: STAIRWELLS
A2.71	VERTICAL TRANSPORT: ELEVATORS
A3.01A	CEILING PLAN - 1ST FLOOR, PART A
A3.01B	CEILING PLAN - 1ST FLOOR, PART B
A3.02A	CEILING PLAN - 2ND FLOOR, PART A
A3.02B	CEILING PLAN - 2ND FLOOR, PART B
A3.51	CEILING DETAILS
A4.01	ROOF PLAN
A4.51	ROOF DETAILS
A5.01	EXTERIOR ELEVATIONS
A5.02	EXTERIOR ELEVATIONS - ENLARGED
A5.03	EXTERIOR ELEVATIONS - ENLARGED
A6.00	BUILDING SECTION
A8.20	INTERIOR WALL TYPES/DETAILS
A8.21	WALL SECTIONS
A8.22	WALL SECTIONS
A8.23	WALL SECTIONS
A8.24	WALL SECTIONS
A8.25	WALL SECTIONS
A8.26	WALL SECTIONS
A8.27	WALL SECTIONS
A8.51	GENERAL DETAILS
A8.52	GENERAL DETAILS
A8.53	GENERAL DETAILS
A8.54	GENERAL DETAILS
A8.55	GENERAL DETAILS
A8.56	GENERAL DETAILS
A7.01	DOOR SCHEDULE
A7.02	WINDOW ELEVATIONS
A7.51	DOOR DETAILS
A7.52	WINDOW DETAILS
A8.01	CASEWORK ELEVATIONS
A8.02	CASEWORK ELEVATIONS
A8.03	CASEWORK ELEVATIONS
A8.51	CASEWORK DETAILS
A8.52	CASEWORK DETAILS
A8.53	CASEWORK DETAILS
F1.01A	FURNISHING PLAN - 1ST FLOOR, PART A
F1.01B	FURNISHING PLAN - 1ST FLOOR, PART B
F1.02A	FURNISHING PLAN - 2ND FLOOR, PART A
F1.02B	FURNISHING PLAN - 2ND FLOOR, PART B
F2.01A	PATTERN PLAN - 1ST FLOOR, PART A
F2.01B	PATTERN PLAN - 1ST FLOOR, PART B
F2.02A	PATTERN PLAN - 2ND FLOOR, PART A
F2.02B	PATTERN PLAN - 2ND FLOOR, PART B

MECHANICAL PLANS	
M0.01	MECHANICAL SCHEDULES
M0.02	HVAC SCHEDULES
M0.03	HVAC SCHEDULES
M0.04	HVAC VENTILATION TABLE
M0.05	HVAC VENTILATION TABLE
M0.06	HVAC VENTILATION TABLE
M0.07	HVAC VENTILATION TABLE
M2.01	HVAC NEW CONSTRUCTION-1st FLOOR: PART A
M2.02	HVAC PIPING-1st FLOOR: PART A
M2.03	HVAC NEW CONSTRUCTION-1st FLOOR: PART B
M2.04	HVAC PIPING-1st FLOOR: PART B
M2.05	ROOF PLUMB: PART A
M2.06	ROOF PLUMB: PART B
M2.07	LARGE SCALE MECHANICAL ROOM
M2.08	LARGE SCALE SECTIONS
M3.01	HVAC CONTROLS
M3.02	HVAC CONTROLS
M4.01	HVAC DETAILS
M4.02	HVAC DETAILS
M5.01	HVAC DETAILS
M5.02	HVAC DETAILS
M6.01	HVAC NEW CONSTRUCTION-2nd FLOOR: PART A
M6.02	HVAC PIPING-2nd FLOOR: PART A
M6.03	HVAC NEW CONSTRUCTION-2nd FLOOR: PART B
M6.04	HVAC PIPING-2nd FLOOR: PART B
P1.01	PLUMBING SCHEDULES
P0.02	SITE PLAN: PLUMBING
P1.01	UNDERGROUND PLUMBING-1st FLOOR: PART A
P1.02	UNDERGROUND PLUMBING-1st FLOOR: PART B
P1.01	PLUMBING-1st FLOOR: PART A
P1.02	PLUMBING-1st FLOOR: PART B
P1.03	PLUMBING-2nd FLOOR: PART A
P1.04	PLUMBING-2nd FLOOR: PART B
P1.05	PLUMBING-ROOF: PART A
P1.06	PLUMBING-ROOF: PART B
P2.01	MEDICAL GAS-1st FLOOR: PART A
P2.02	MEDICAL GAS-1st FLOOR: PART B
P2.03	MEDICAL GAS-2nd FLOOR: PART A
P2.04	MEDICAL GAS-2nd FLOOR: PART B
P3.01	LARGE SCALE PLUMBING: MECHANICAL ROOM
P3.02	LARGE SCALE PLUMBING: KITCHEN
P4.01	PLUMBING RISERS
P5.01	PLUMBING DETAILS
P5.02	PLUMBING DETAILS

ELECTRICAL PLANS	
E0.01	ELECTRICAL INDEX & SCHEDULES
E0.02	ELECTRICAL LEGENDS
E0.03	ELECTRICAL EQUIPMENT CONNECTION SCHEDULES
E0.04	ELECTRICAL EQUIPMENT SCHEDULES
E1.01	ELECTRICAL-SITE PLAN
E2.01	LIGHTING-1st FLOOR: PART A
E2.02	LIGHTING-1st FLOOR: PART B
E2.03	LIGHTING-2nd FLOOR: PART A
E2.04	LIGHTING-2nd FLOOR: PART B
E3.01	POWER-1st FLOOR: PART A
E3.02	POWER-1st FLOOR: PART B
E3.03	POWER-2nd FLOOR: PART A
E3.04	POWER-2nd FLOOR: PART B
E4.01	SYSTEMS-1st FLOOR: PART A
E4.02	SYSTEMS-1st FLOOR: PART B
E4.03	SYSTEMS-2nd FLOOR: PART A
E4.04	SYSTEMS-2nd FLOOR: PART B
E5.01	ELECTRICAL-ROOF: PART A
E5.02	ELECTRICAL-ROOF: PART B
E6.01	LARGE SCALE ELECTRICAL
E6.02	LARGE SCALE ELECTRICAL
E7.01	ELECTRICAL POWER DISTRIBUTION: RISER
E7.02	ELECTRICAL POWER DISTRIBUTION: NORMAL ONE LINE DIAGRAM
E7.03	ELECTRICAL POWER DISTRIBUTION: ESSENTIAL ONE LINE DIAGRAM
E7.04	ELECTRICAL POWER DISTRIBUTION: ESSENTIAL ONE LINE DIAGRAM
E8.01	TELECOMMUNICATION DETAILS
E8.02	ELECTRICAL DETAILS
E8.01	ELECTRICAL PANELBOARD SCHEDULES: NORMAL SYSTEM
E8.02	ELECTRICAL PANELBOARD SCHEDULES: ESSENTIAL SYSTEM
E8.03	ELECTRICAL PANELBOARD SCHEDULES: ESSENTIAL SYSTEM
FP-1	COVER SHEET
FP-2	FIRST FLOOR PART A PIPING PLAN
FP-3	FIRST FLOOR PART B PIPING PLAN
FP-4	FIRST FLOOR PART A RCP
FP-5	FIRST FLOOR PART B RCP
FP-6	SECOND FLOOR FIRE SPRINKLER PIPING PLAN
FP-7	SECOND FLOOR RCP

KITCHEN PLANS	
FS1.1	KITCHEN EQUIPMENT
FS1.2	KITCHEN PLUMBING
FS1.3	KITCHEN ELECTRICAL
FS1.4	KITCHEN VENTILATION

What to remember

- Notes
- Key Words
- Typical Details
- General Notes
- Look into all the disciplines



Example #1



What is the total number of luminaries connected to the emergency electrical system located within patient room 2B12?

What do you need to look for: 2B12 and find it in the electrical sheet because you need to look also for the legend Identify the emergency/critical light fixture.

Note: **2B12** location is on the 2nd floor.

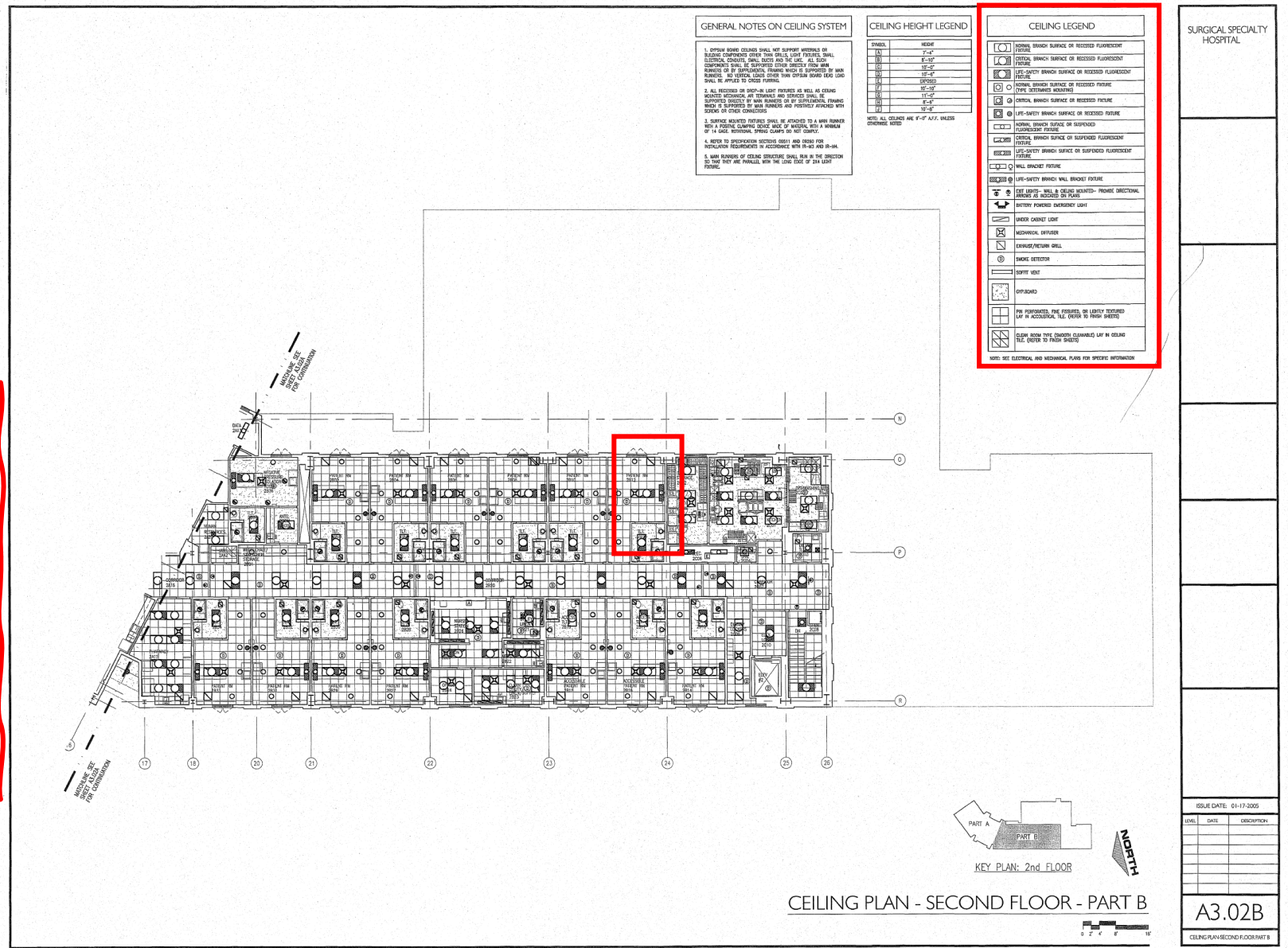

What is the total number of luminaries connected to the emergency electrical system located within patient room 2B12?

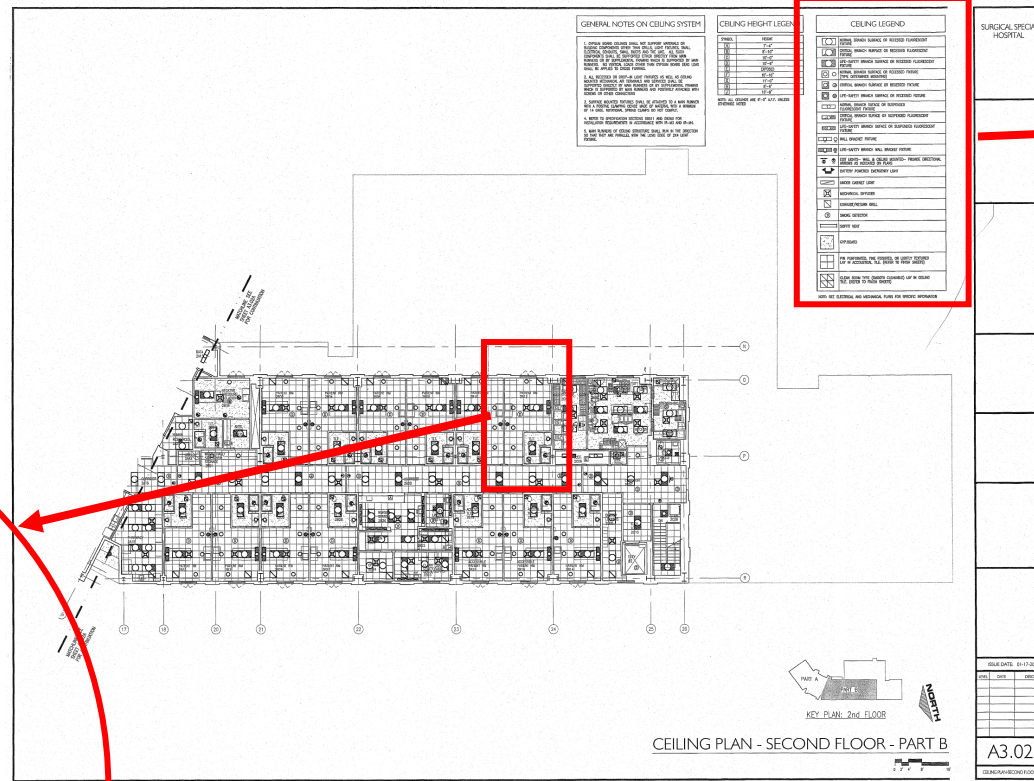
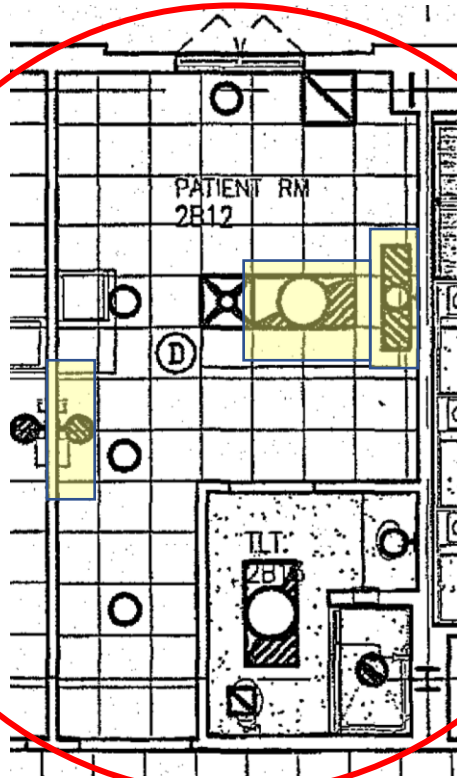

CEILING LEGEND	
	NORMAL BRANCH SURFACE OR RECESSED FLUORESCENT FIXTURE
	CRITICAL BRANCH SURFACE OR RECESSED FLUORESCENT FIXTURE
	LIFE-SAFETY BRANCH SURFACE OR RECESSED FLUORESCENT FIXTURE
	NORMAL BRANCH SURFACE OR RECESSED FIXTURE (TYPE DETERMINES MOUNTING)
	CRITICAL BRANCH SURFACE OR RECESSED FIXTURE
	LIFE-SAFETY BRANCH SURFACE OR RECESSED FIXTURE
	NORMAL BRANCH SURFACE OR SUSPENDED FLUORESCENT FIXTURE
	CRITICAL BRANCH SURFACE OR SUSPENDED FLUORESCENT FIXTURE
	LIFE-SAFETY BRANCH SURFACE OR SUSPENDED FLUORESCENT FIXTURE
	WALL BRACKET FIXTURE
	LIFE-SAFETY BRANCH WALL BRACKET FIXTURE

Ceiling Legend: Find the Critical Light Fixture Symbols
In 2B12 see which Light Fixture there are

What is the total number of luminaries connected to the emergency electrical system located within patient room 2B12?

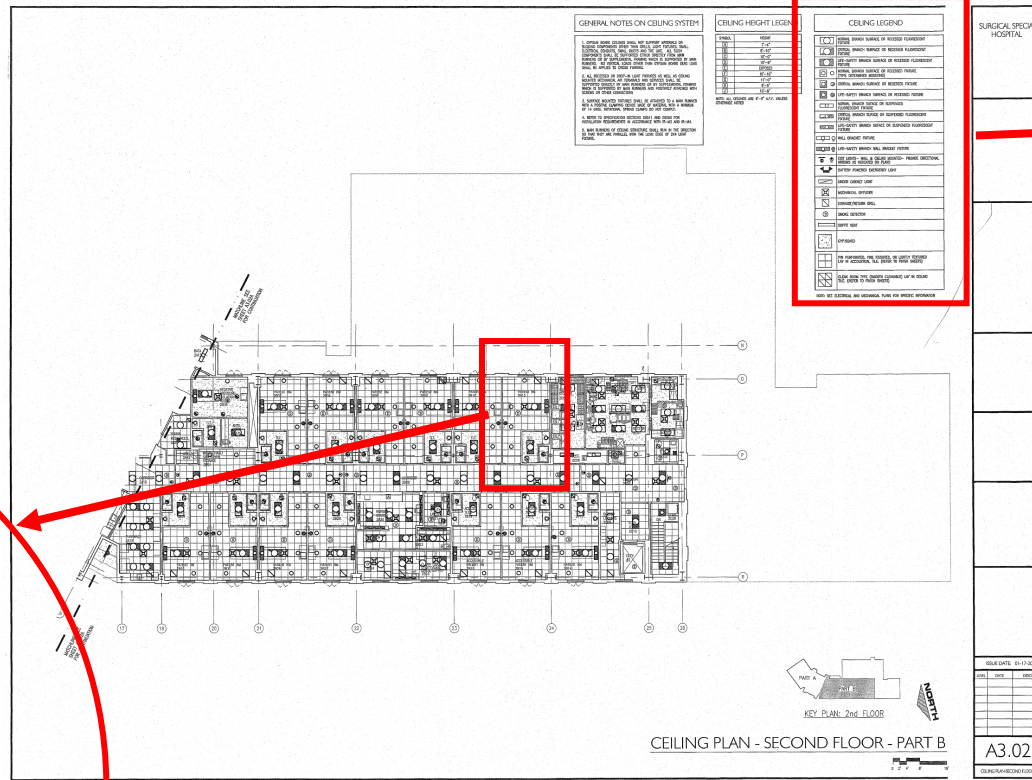
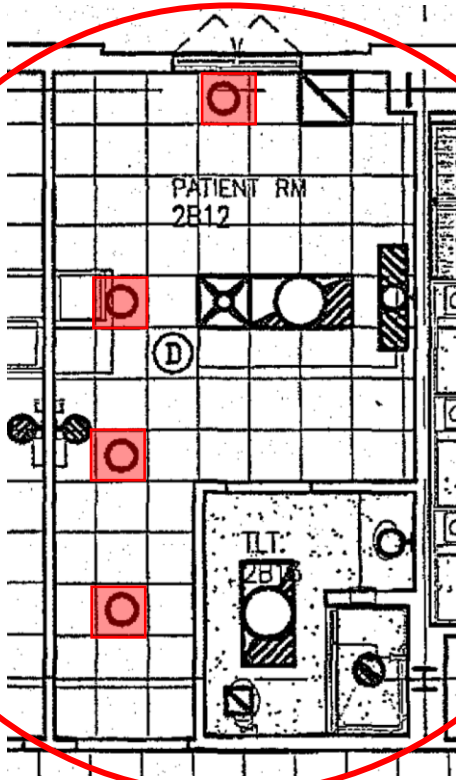

CEILING LEGEND	
	NORMAL BRANCH SURFACE OR RECESSED FLUORESCENT FIXTURE
	CRITICAL BRANCH SURFACE OR RECESSED FLUORESCENT FIXTURE
	LIFE-SAFETY BRANCH SURFACE OR RECESSED FLUORESCENT FIXTURE
	NORMAL BRANCH SURFACE OR RECESSED FIXTURE (TYPE DETERMINES MOUNTING)
	CRITICAL BRANCH SURFACE OR RECESSED FIXTURE
	LIFE-SAFETY BRANCH SURFACE OR RECESSED FIXTURE
	NORMAL BRANCH SURFACE OR SUSPENDED FLUORESCENT FIXTURE
	CRITICAL BRANCH SURFACE OR SUSPENDED FLUORESCENT FIXTURE
	LIFE-SAFETY BRANCH SURFACE OR SUSPENDED FLUORESCENT FIXTURE
	WALL BRACKET FIXTURE
	LIFE-SAFETY BRANCH WALL BRACKET FIXTURE

In the ceiling plan, there are also other light fixtures. Those are normal. Not part of the question

What is the total number of luminaires connected to the emergency electrical system located within patient room 2B12?

- A. 1
- B. 2
- C. 3
- D. 4

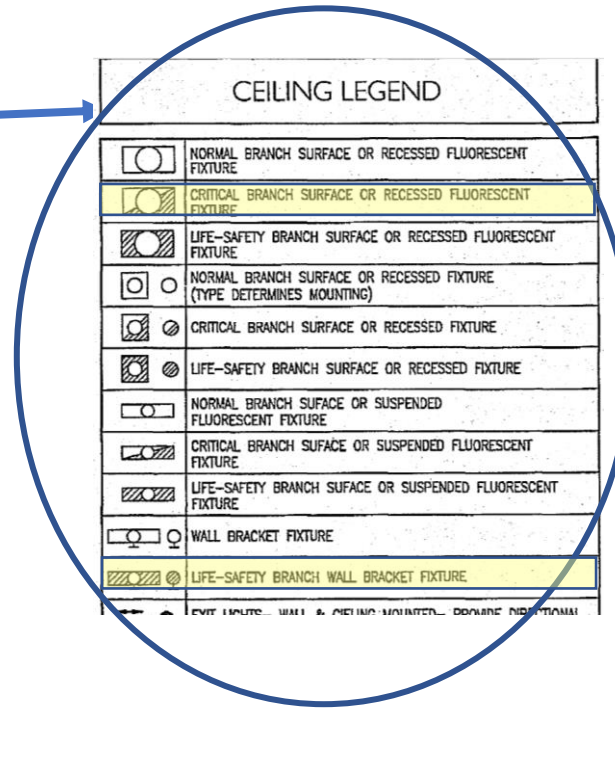
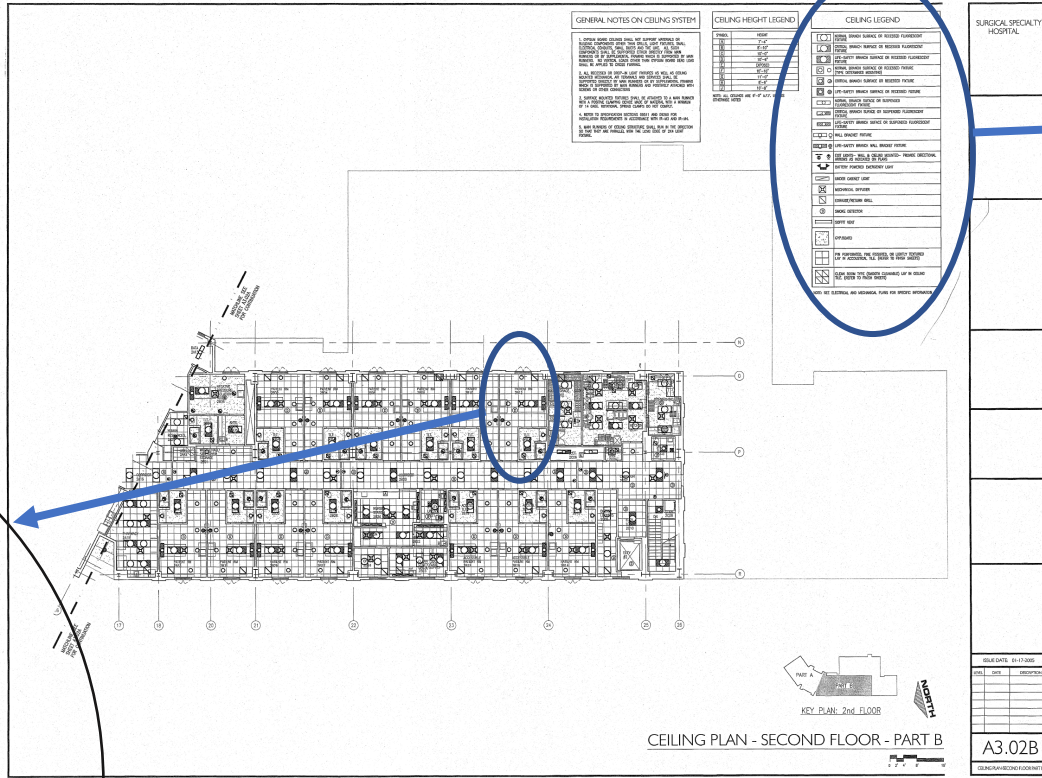
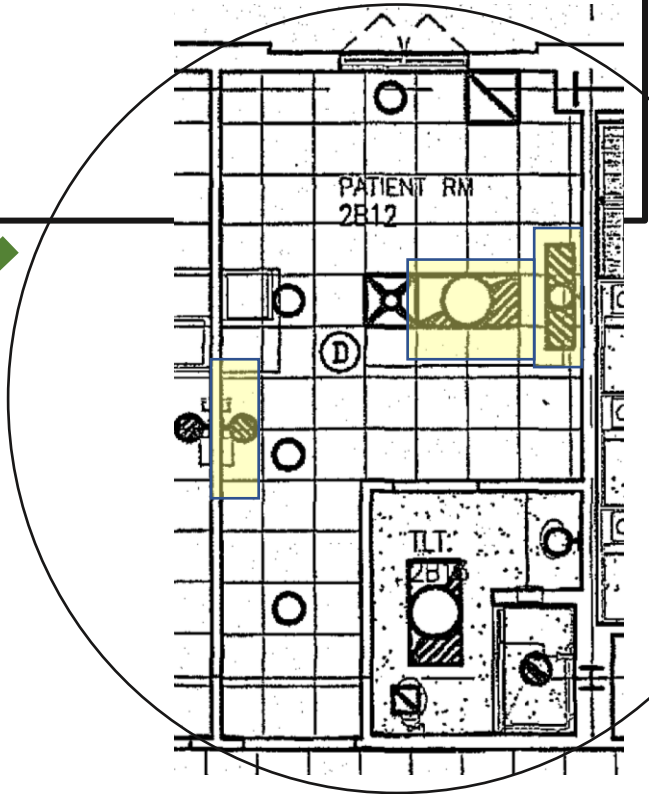

Example #2



The exterior screen wall framing surrounding RTU equipment at the roof shall have a built up finish in the following order:

- A. building wrap, stucco over metal lath
- B. 1/2" exterior sheathing, building wrap, stucco over metal lath.
- C. 5/8" WP gypsum, building wrap, stucco over metal lath
- D. 3/4" cementitious board, plaster finish

Where is the exterior screen wall framing surrounding RTU equipment?

How many RTU are there in the project? 5

Where the detail for screen wall could be?

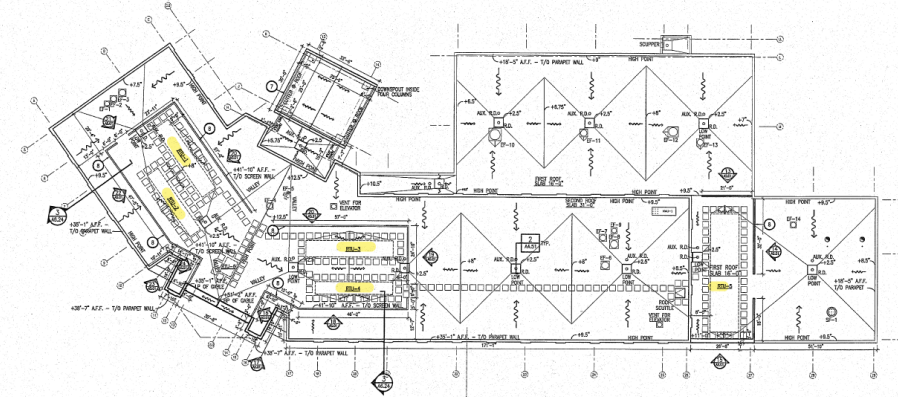

- GENERAL NOTES:**
1. ALL ROOF MEMBERS SHALL BE SINGLE PLY BUILT-UP FOR TYPICAL. SEE SPECIFICATIONS FOR ADDITIONAL INFORMATION.
 2. ROOF TOP EQUIPMENT AND PENETRATIONS SHALL BE MARKED WITH MECHANICAL, ELECTRICAL, AND PLUMBING SYMBOLS.
 3. PROVIDE DETAILS AT ALL ROOF EQUIPMENT TO PROVIDE WEATHER DRAINAGE. WEATHER ROOF DRAIN DETAILS TO BE AT 1/4" PER FOOT MIN.
 4. ROOF SLOPE - 1/4" PER FOOT MIN.
- ROOF LEGEND:**
- + VENT SYMBOL SEE S/A/AS1
 - ⊠ ROOF DRAIN WITH AIR/FLUE/DRY BLOW DOWN SEE S/A/AS1
 - OF - CORNER DRAIN SEE S/A/AS1
 - ⊞ ROOF DOWNSIDE SEE S/A/AS1
 - FLOW LINE DIRECTION OF SLOPE
 - SLOPE
 - ELEVATION SYMBOL REFERENCE TO CORNER POINT OF DRAIN
- SCREEN WALLS:**
- SINGLE PLY BUILT UP ROOF SEE S/A/AS1
 - TYPICAL FORMER ROOF FINISHING SEE S/A/AS1
 - ROOF TOP LINE SEE S/A/AS1
 - PRE-FABRICATED ANNALS SEE SPECIFICATIONS
 - CIRCLES INDICATE INSTALLATION AT 1/4" PER FOOT MIN.
 - SEE SPECIFICATIONS REFER TO STRUCTURAL DRAWINGS FOR SIZE AND LOCATION OF FRAMES MEMBERS.
 - STANDING SEAM METAL ROOF
 - SCREEN WALL

OVERALL ROOF PLAN



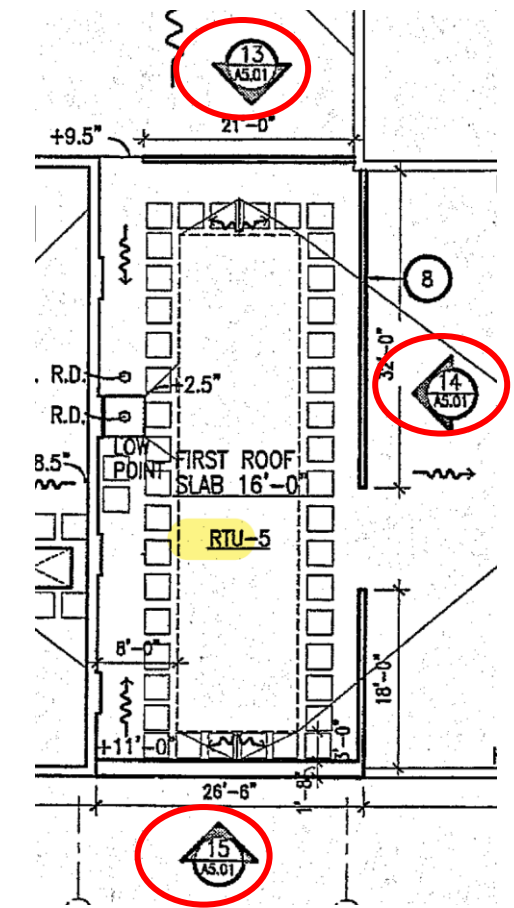
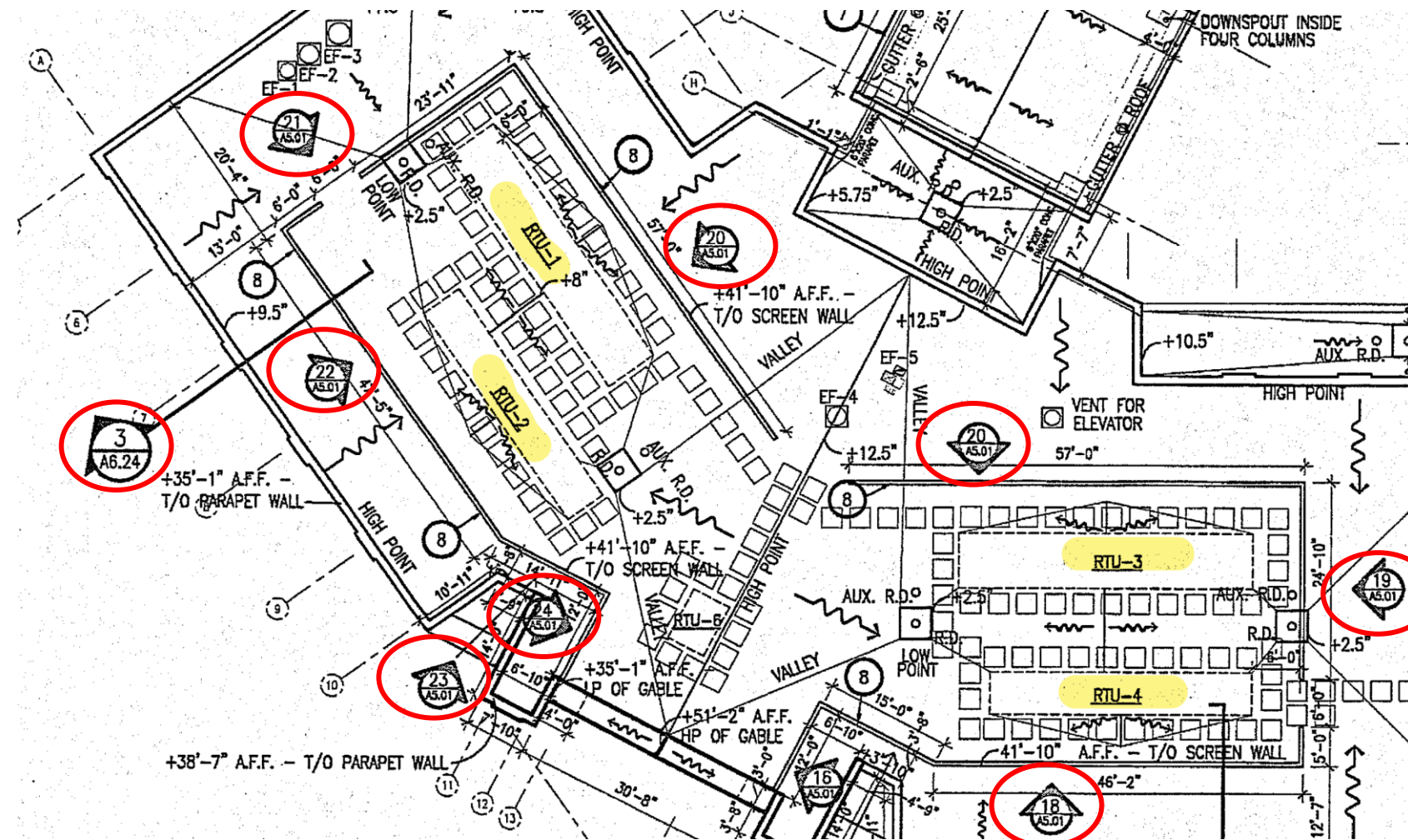

How can you find the detail?
 Maybe by looking on callout detail
 from exterior elevations or sections?

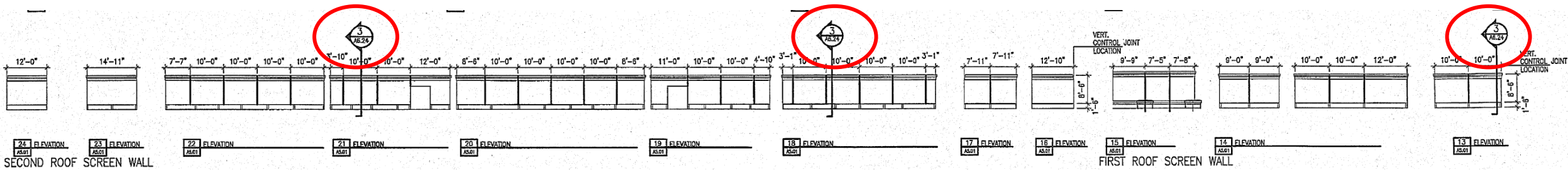

Is 3/A6.24 the right detail?

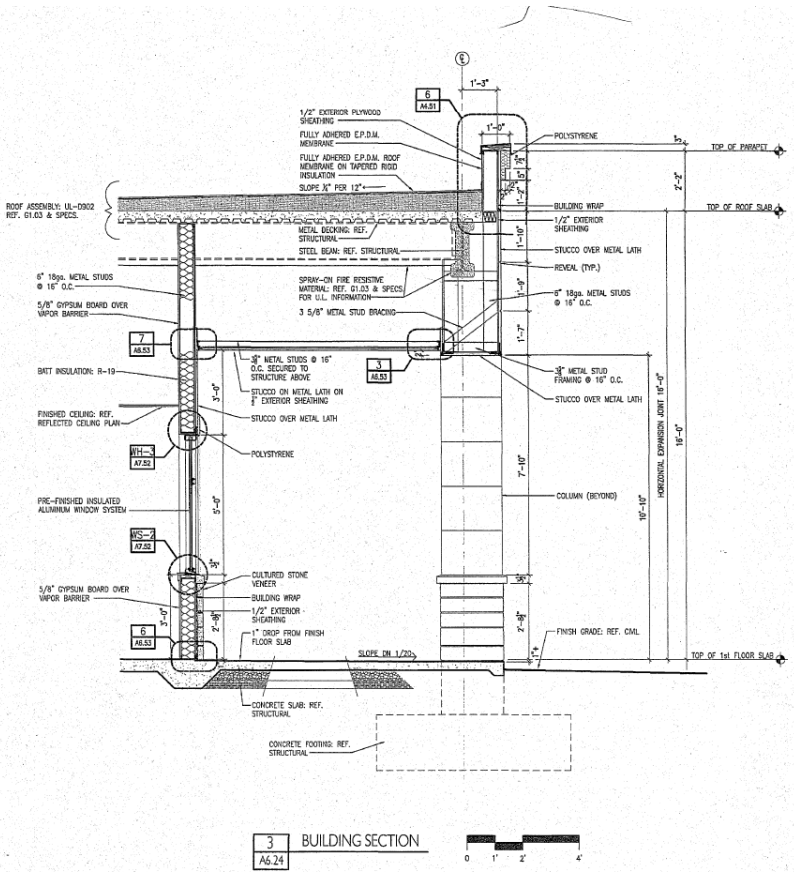

No

The exterior screen wall framing surrounding RTU equipment at the roof shall have a built up finish in the following order:

- A. building wrap, stucco over metal lath
- B. 1/2" exterior sheathing, building wrap, stucco over metal lath.
- C. 5/8" WP gypsum, building wrap, stucco over metal lath
- D. 3/4" cementitious board, plaster finish

Options:
Look into all the drawings for a call out like this

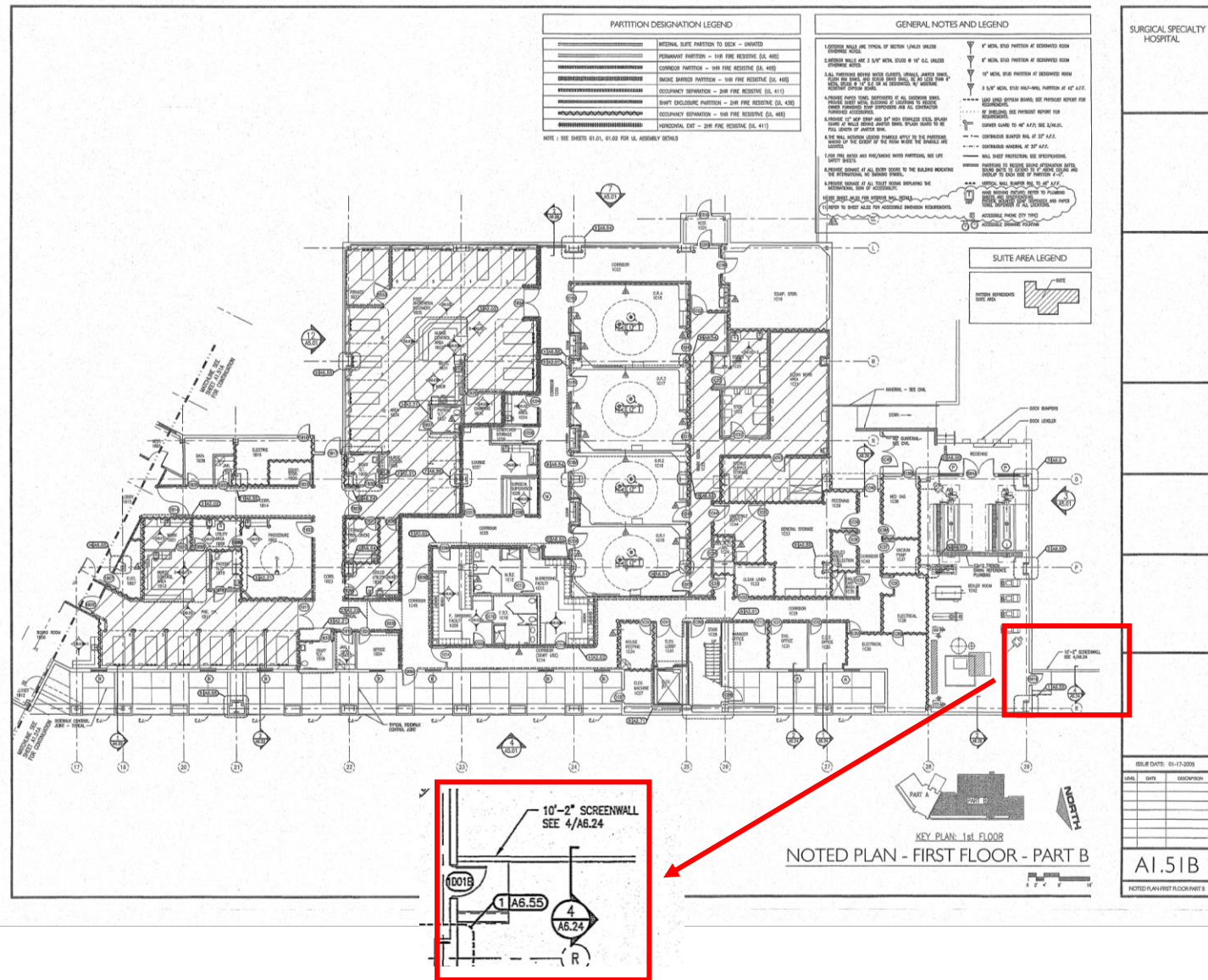

The exterior screen wall framing surrounding RTU equipment at the roof shall have a built up finish in the following order:

- A. building wrap, stucco over metal lath
- B. 1/2" exterior sheathing, building wrap, stucco over metal lath.
- C. 5/8" WP gypsum, building wrap, stucco over metal lath
- D. 3/4" cementitious board, plaster finish



Then, you are finally into the detail and you can see the actual sequence of installation

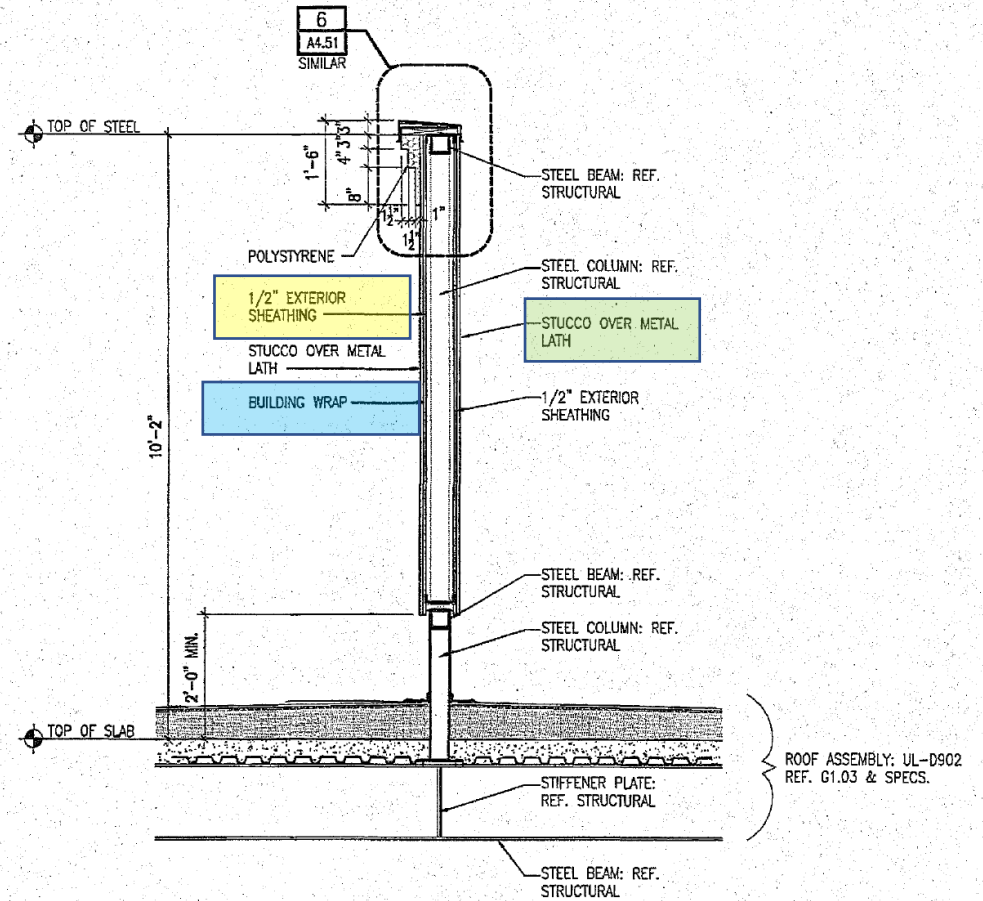

1 ROOF SCREEN WALL
A6.24



Example #3



Soiled Utility Room 2B21
lower casework is _____
high and _____ long.

First thing to do is to find the room. You need to look for interior elevations. So, where can you find it?

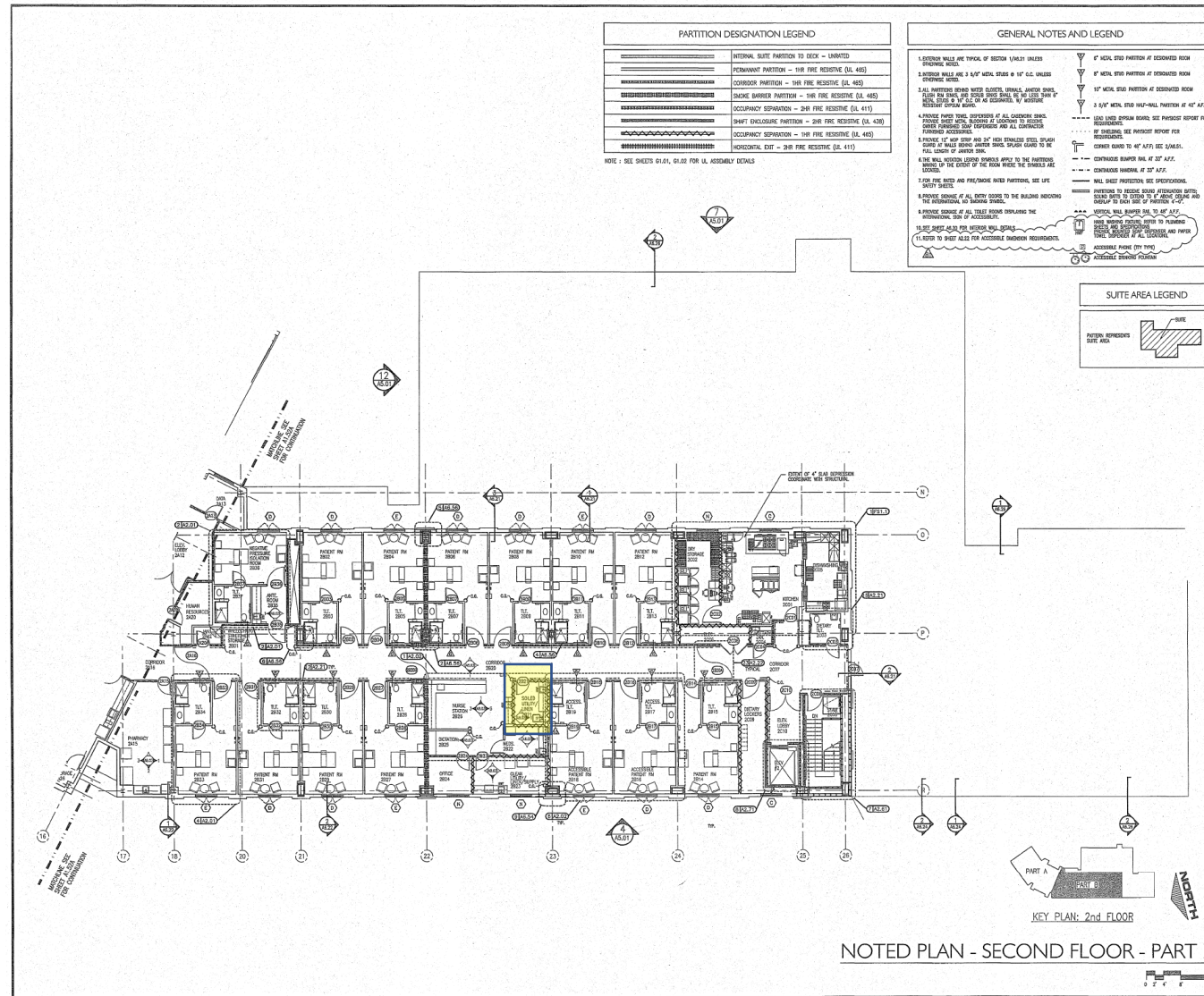
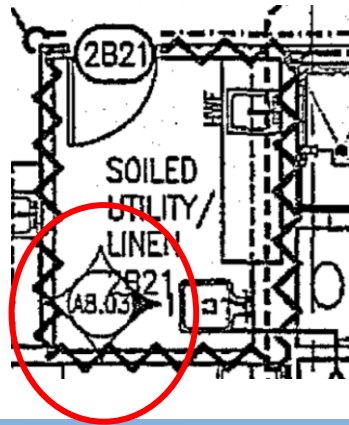

SURGICAL SPECIALTY HOSPITAL

ISSUE DATE: 01-17-2025

LEVEL	DATE	DESCRIPTION

A1.52B

NOTED PLAN SECOND FLOOR PART B

Soiled Utility Room 2B21
lower casework is _____
high and _____ long.

- A. 2'-10", 6'-9"
- B. 2'-10", 6'-11"
- C. 3'-0", 7'-0"
- D. None of the above



Once you found the
elevation, look for
dimension of casework.

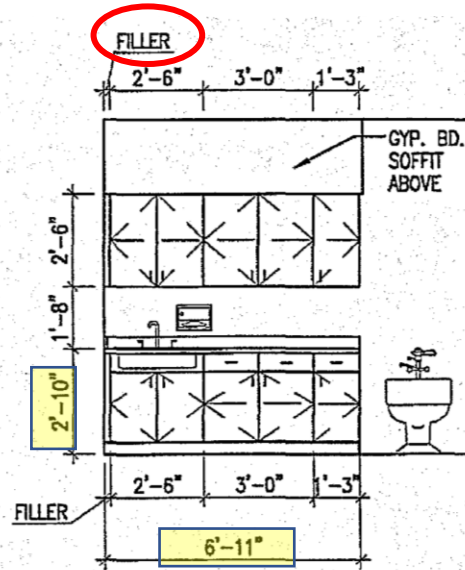

SOILED UTILITY 2B21

1

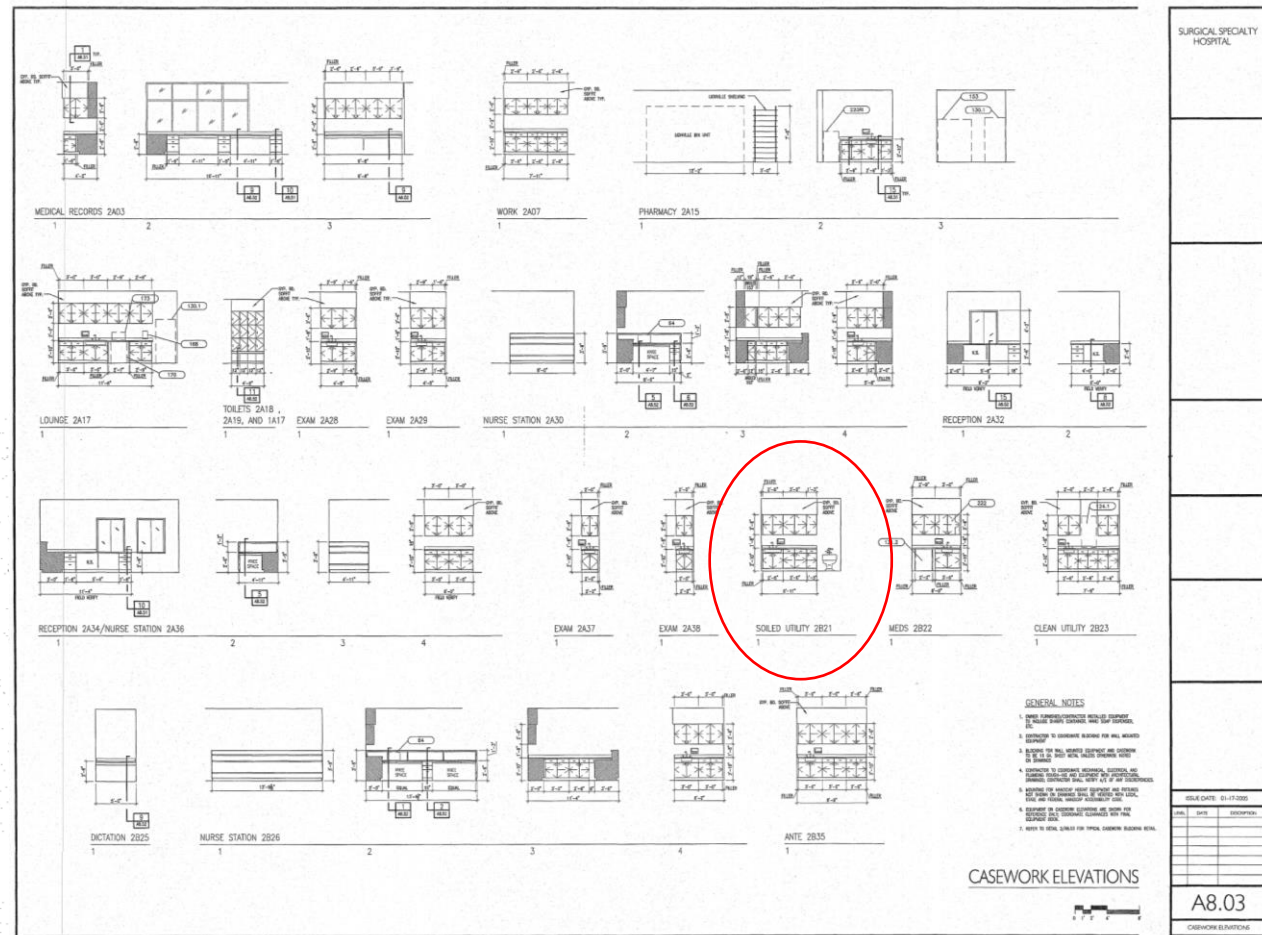

Example #4



The framed header assembly for door No. 1B03B shall consist of _____.

- A. 2-6" x 18 ga. studs with 2-6" x 18 ga. Tracks
- B. 2-4" x 18 ga. studs with 2-4" x 18 ga. Tracks
- C. 2-6" x 18 ga. studs with 3-6" x 18 ga. Tracks
- D. 2-4" x 18 ga. studs with 3-4" x 18 ga. tracks

First of all, you need to look into the door schedule, to see where the header detail is located

DOOR SCHEDULE										DOOR SCHEDULE										SURGICAL SECURITY HOSPITAL													
DOOR NUMBER	TYPE	WIDTH	HEIGHT	PAIR	ALUMINUM	HOLLOW METAL	SOLID CORE WOOD	HOLLOW CORE WOOD	WOOD W/ PLASTIC	TEMPERED GLASS	INSULATED GLASS	WIRED GLASS	DOUBLE EGRESS	SOLID WOOD BI-FOLD	20 MINUTE LABEL	B LABEL 1 HR	C LABEL 45 MIN.	B LABEL 1 1/2 H	"S" SMOKE SEAL	TYPE	HOLLOW METAL	ALUMINUM	WOOD	HEAD	JAMB	SILL	PROVIDE DRY CONTACT IF FRAME-COORDINATE W/ THRESHOLD	3/4" UNDERCUT	HARDWARE SET NU	DOOR NUMBER	DETAILS	REMARKS	
1A01A	D3	3'-8 1/2"	6'-8"																														
1B03B	D1	3'-8 1/2"	7'-0"																		D												
1B03C	NL	4'-0"	7'-0"																		S												

DOOR NUMBER	TYPE	WIDTH	HEIGHT	PAIR	ALUMINUM	HOLLOW METAL	SOLID CORE WOOD	HOLLOW CORE WOOD	WOOD W/ PLASTIC	TEMPERED GLASS	INSULATED GLASS	WIRED GLASS	DOUBLE EGRESS	SOLID WOOD BI-FOLD	20 MINUTE LABEL	B LABEL 1 HR	C LABEL 45 MIN.	B LABEL 1 1/2 H	"S" SMOKE SEAL	TYPE	HOLLOW METAL	ALUMINUM	WOOD	HEAD	JAMB	SILL	PROVIDE DRY CONTACT IF FRAME-COORDINATE W/ THRESHOLD	3/4" UNDERCUT	HARDWARE SET NU	DOOR NUMBER	DETAILS	REMARKS		
1A01A	D3	3'-8 1/2"	6'-8"																														TIED INTO FIRE ALARM	
1B03B	D1	3'-8 1/2"	7'-0"																		D												3	MAGNETIC LOCK
1B03C	NL	4'-0"	7'-0"																		S											4	ELECTRIC STRIKE	
																																5	AUTOMATIC OPERATION	
																																	6	CARD READER - COORD. WITH SECURITY
																																	7	LIGHT SEALS
																																	8	REMOTE LOCK RELEASE

The framed header assembly for door No. 1B03B shall consist of _____.

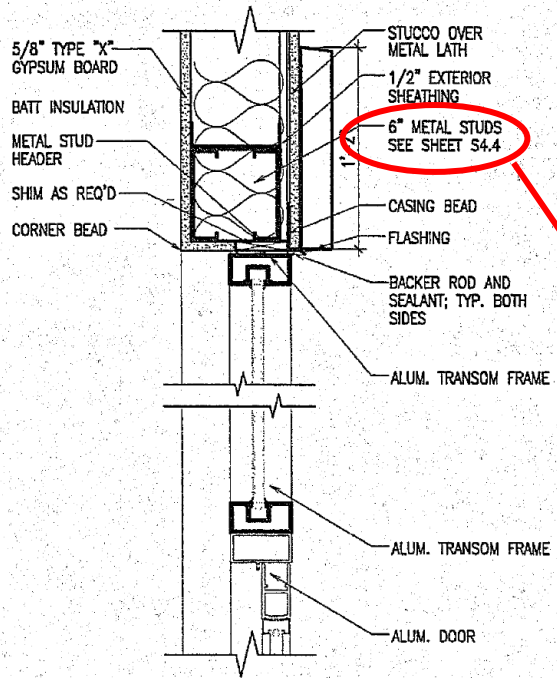

DH-8

HEAD DETAILS

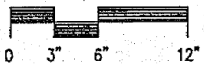

DOOR NUMBER	TYPE	WIDTH	HEIGHT 6'-8"	HEIGHT 7'-0"	PAIR	ALUMINUM	HOLLOW METAL	SOLID CORE WOOD	HOLLOW CORE WOOD	WOOD W/ PLASTIC	TEMPERED GLASS	INSULATED GLASS	WIRED GLASS	DOUBLE EGRESS	SOLID WOOD BI-FOLD	20 MINUTE LABEL	B LABEL 1 HR	C LABEL 45 MIN.	B LABEL 1 1/2 H	"S" SMOKE SEAL	TYPE	HOLLOW METAL	ALUMINUM	WOOD	HEAD	JAMB	SILL	PROVIDE DRY CONTACT IF FRAME-COORDINATE W/ THRESHOLD	3/4" UNDERCUT	HARDWARE SET NUMBER	DOOR NUMBER	ACCESSORIES		
1A01A	D3	3'-8"																															TIED INTO FIRE ALARM MAGNETIC LOCK ELECTRIC STRIKE AUTOMATIC OPERATION CARD READER - COORD. WITH SECURITY LIGHT SEALS REMOTE LOCK RELEASE	
1B03B	D1	3'-8"																															WEATHERSTRIP	
1B03C	NL	4'-0"																																

Then go to Door Details (A7.51 from Master Drawing Index).
 Look for DH-8 for Head detail.
 Look also for the Width of the door (3'-8")

This information directs you to S4.4

The framed header assembly for door No. 1B03B shall consist of _____.

- A. 2-6" x 18 ga. studs with 2-6" x 18 ga. Tracks
- B. 2-4" x 18 ga. studs with 2-4" x 18 ga. Tracks
- C. 2-6" x 18 ga. studs with 3-6" x 18 ga. Tracks
- D. 2-4" x 18 ga. studs with 3-4" x 18 ga. tracks



Now that you are on S4.4, look for the Header Schedule.

HEADER SCHEDULE			
ROUGH OPENING	MEMBERS	BUILT-UP SECTION	NOTES
0'-0" TO 6'-4"	2-6", 18 Ga STUDS W/2-6", 18 Ga TRACKS		
6'-5" TO 8'-4"	2-6", 18 Ga STUDS W/2-6", 18 Ga TRACKS		
8'-5" TO 13'-0"	2-6", 18 Ga STUDS W/3-6", 14 Ga TRACKS		

NOTE:
1.) ALL MEMBERS TO HAVE 33 KSI YIELD STRENGTH.
2.) TRACK SECTIONS TO HAVE 1 1/4" LEG MIN.
3.) STUD SECTIONS HAVE 1 5/8" FLANGES, TYP. U.N.O.
4.) FASTEN EACH TRACK W/2-#1 SCREWS @ 16"c/c FOR BUILT-UP SECTION.

② HEADER SCHEDULE



Example #5



According to the plan, the ceiling finish within work room 1C25 shall be _____.

What do you need to look for?
Ceiling Plans. Go to Master Drawing Index and you will find Ceiling Plans

- A3.01A CEILING PLAN - 1ST FLOOR, PART A
- A3.01B CEILING PLAN - 1ST FLOOR, PART B
- A3.02A CEILING PLAN - 2ND FLOOR, PART A
- A3.02B CEILING PLAN - 2ND FLOOR, PART B

The image shows a set of architectural drawing sheets. The 'MASTER DRAWING INDEX' sheet is highlighted with a red box, showing a list of drawing titles and their corresponding sheet numbers. The 'ABBREVIATIONS' and 'MATERIAL DESIGNATIONS' sheets provide symbols and codes used in the drawings. The 'CONSULTANTS' sheet lists the names of the consulting firms involved in the project.

According to the plan, the ceiling finish within work room 1C25 shall be _____.

Then, you need to find 1C25.

You can navigate to any floor plans to find them.

For example, you could use the Ceiling Plans.

And you will find 1C25 on A3.01B

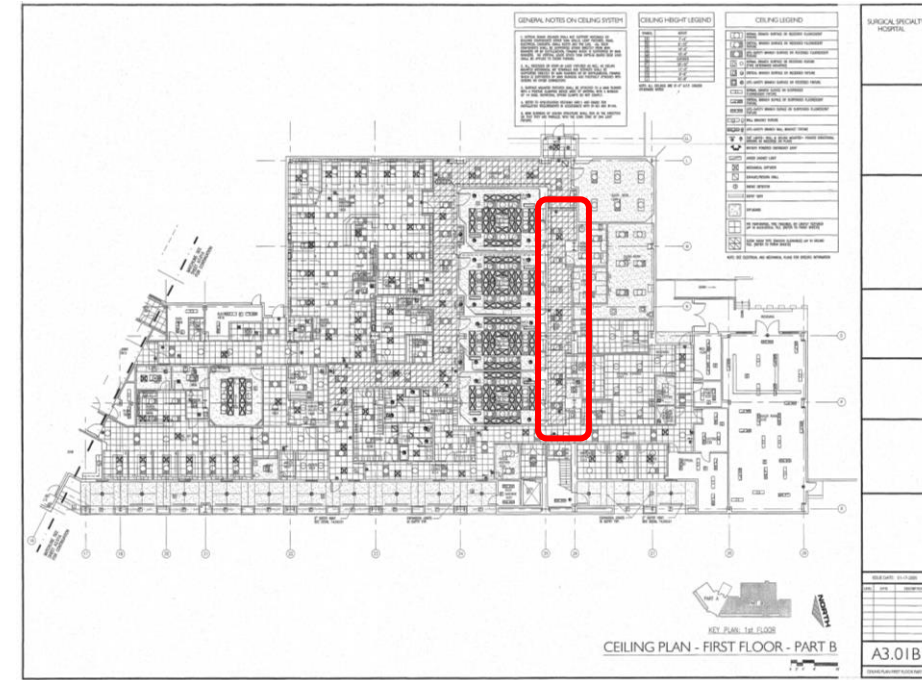
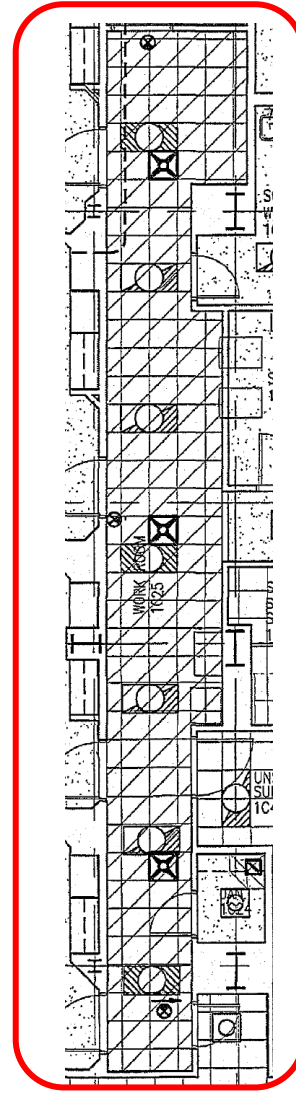

According to the plan, the ceiling finish within work room 1C25 shall be _____.

In the same drawing, you can find the Ceiling Legend.

CEILING LEGEND	
	NORMAL BRANCH SURFACE OR RECESSED FLUORESCENT FIXTURE
	CRITICAL BRANCH SURFACE OR RECESSED FLUORESCENT FIXTURE
	LIFE-SAFETY BRANCH SURFACE OR RECESSED FLUORESCENT FIXTURE
	NORMAL BRANCH SURFACE OR RECESSED FIXTURE (TYPE DETERMINES MOUNTING)
	CRITICAL BRANCH SURFACE OR RECESSED FIXTURE
	LIFE-SAFETY BRANCH SURFACE OR RECESSED FIXTURE
	NORMAL BRANCH SURFACE OR SUSPENDED FLUORESCENT FIXTURE
	CRITICAL BRANCH SURFACE OR SUSPENDED FLUORESCENT FIXTURE
	LIFE-SAFETY BRANCH SURFACE OR SUSPENDED FLUORESCENT FIXTURE
	WALL BRACKET FIXTURE
	LIFE-SAFETY BRANCH WALL BRACKET FIXTURE
	EXIT LIGHTS- WALL & CEILING MOUNTED- PROVIDE DIRECTIONAL ARROWS AS INDICATED ON PLANS
	BATTERY POWERED EMERGENCY LIGHT
	UNDER CABINET LIGHT
	MECHANICAL DIFFUSER
	EXHAUST/RETURN GRILL
	SMOKE DETECTOR
	SOFFIT VENT
	GYP. BOARD
	PIN PERFORATED, FINE FISSURED, OR LIGHTLY TEXTURED LAY IN ACOUSTICAL TILE. (REFER TO FINISH SHEETS)
	CLEAN ROOM TYPE (SMOOTH CLEANABLE) LAY IN CEILING TILE. (REFER TO FINISH SHEETS)

NOTE: SEE ELECTRICAL AND MECHANICAL PLANS FOR SPECIFIC INFORMATION

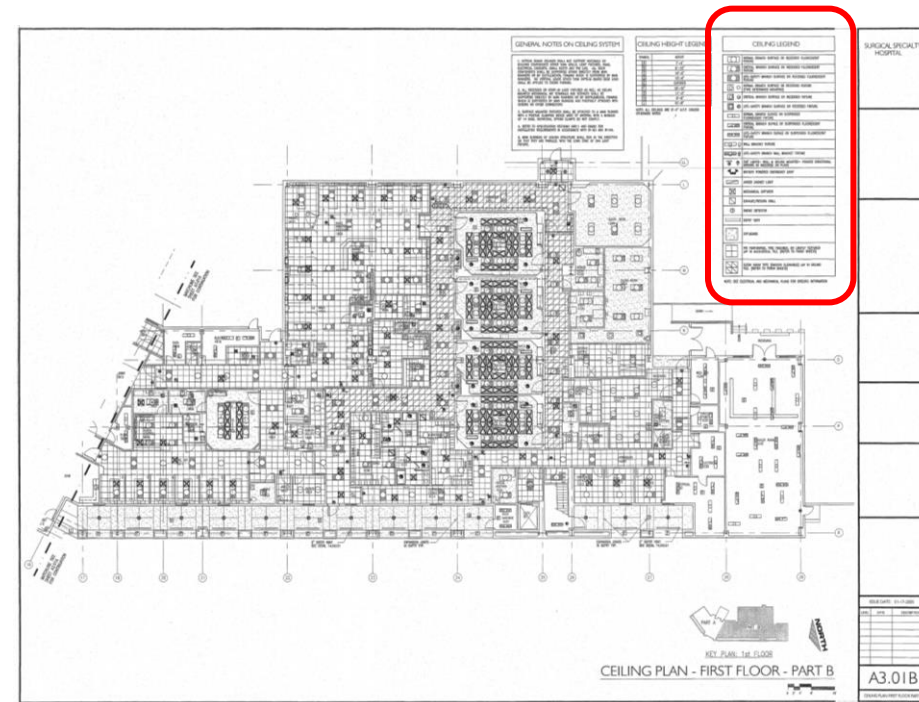

According to the plan, the ceiling finish within work room 1C25 shall be _____.

- A. pin perforated tile
- B. lightly textured tile
- C. smooth cleanable gypsum board
- D. smooth cleanable lay in tile

Now, put together the information you found...

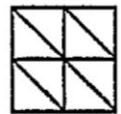

CLEAN ROOM TYPE (SMOOTH CLEANABLE) LAY IN CEILING TILE. (REFER TO FINISH SHEETS)

CEILING LEGEND	
	NORMAL BRANCH SURFACE OR RECESSED FLUORESCENT FIXTURE
	CRITICAL BRANCH SURFACE OR RECESSED FLUORESCENT FIXTURE
	LIFE-SAFETY BRANCH SURFACE OR RECESSED FLUORESCENT FIXTURE
	NORMAL BRANCH SURFACE OR RECESSED FIXTURE (TYPE DETERMINES MOUNTING)
	CRITICAL BRANCH SURFACE OR RECESSED FIXTURE
	LIFE-SAFETY BRANCH SURFACE OR RECESSED FIXTURE
	NORMAL BRANCH SURFACE OR SUSPENDED FLUORESCENT FIXTURE
	CRITICAL BRANCH SURFACE OR SUSPENDED FLUORESCENT FIXTURE
	LIFE-SAFETY BRANCH SURFACE OR SUSPENDED FLUORESCENT FIXTURE
	WALL BRACKET FIXTURE
	LIFE-SAFETY BRANCH WALL BRACKET FIXTURE
	EXIT LIGHTS- WALL & CEILING MOUNTED- PROVIDE DIRECTIONAL ARROWS AS INDICATED ON PLANS
	BATTERY POWERED EMERGENCY LIGHT
	UNDER CABINET LIGHT
	MECHANICAL DIFFUSER
	EXHAUST/RETURN GRILL
	SMOKE DETECTOR
	SOFFIT VENT
	GYP. BOARD
	PIN PERFORATED, FINE FISSURED, OR LIGHTLY TEXTURED LAY IN ACCOUSTICAL TILE. (REFER TO FINISH SHEETS)
	CLEAN ROOM TYPE (SMOOTH CLEANABLE) LAY IN CEILING TILE. (REFER TO FINISH SHEETS)

NOTE: SEE ELECTRICAL AND MECHANICAL PLANS FOR SPECIFIC INFORMATION

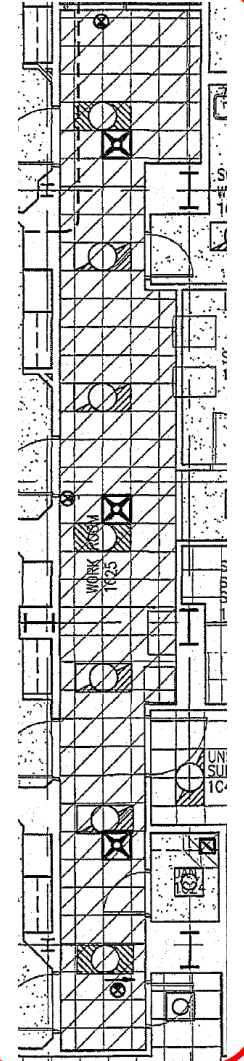

Homework

Homework #1

What is the minimum clear
Opening height for knee space at
the countertop in Room 1A16?

2' – 0 ½"

2' – 6"

2' – 10"

5' – 0"

Homework #2

The floor finish for the operating
room is _____.

A. Carpet

B. sheet vinyl

C. resin

D. none of the above



Resolution

Homework #1

What is the minimum clear
Opening height for knee space at
the countertop in Room 1A16?

- A. 2' – 0 ½"
- B. 2' – 6"
- C. 2' – 10"
- D. 5' – 0"

Homework #2

The floor finish for the operating
room is _____.

- A. Carpet
- B. sheet vinyl
- C. resin
- D. none of the above



What is the minimum clear
Opening height for knee space at
the countertop in Room 1A16?

First of all, you need to find room 1A16, and look for the
interior elevation callout. Where do you need to look?
1A16 is on the 1st floor...

A1.51A	NOTED PLAN – 1ST FLOOR, PART A
A1.51B	NOTED PLAN – 1ST FLOOR, PART B
A1.52A	NOTED PLAN – 2ND FLOOR, PART A
A1.52B	NOTED PLAN – 2ND FLOOR, PART B



What is the minimum clear Opening height for knee space at the countertop in Room 1A16?

Room 1A16 is on A1.51A.
Look for the interior elevation callout.

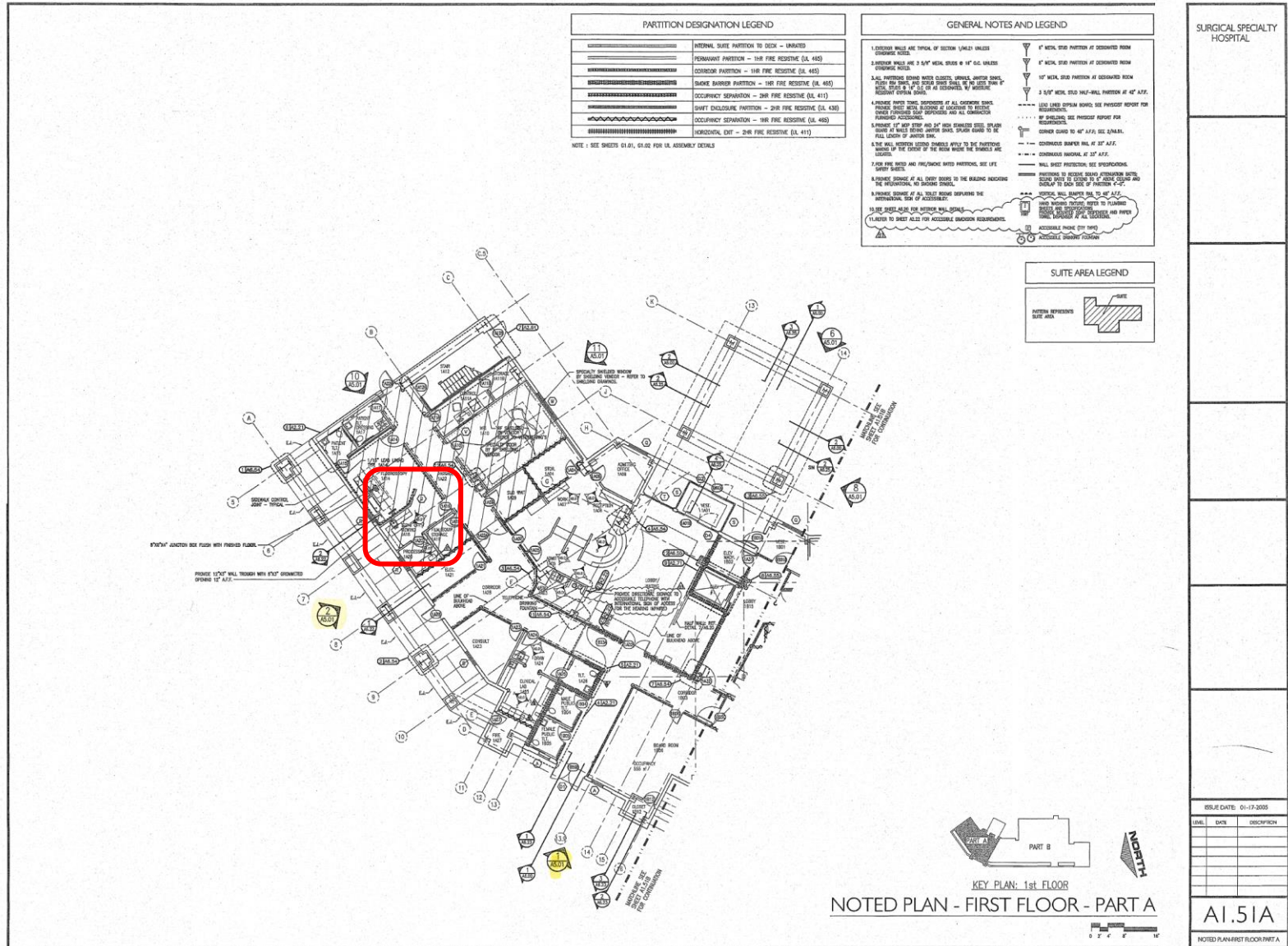
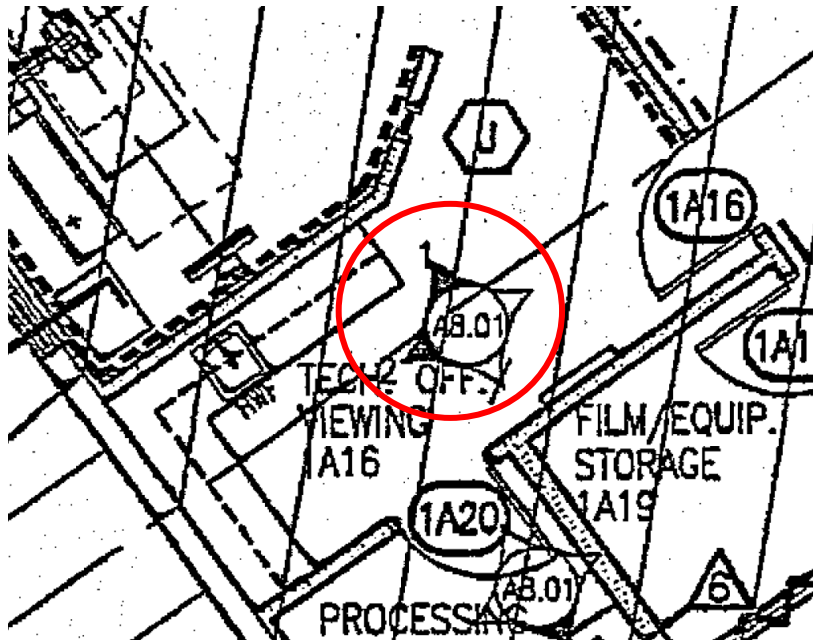

What is the minimum clear Opening height for knee space at the countertop in Room 1A16?

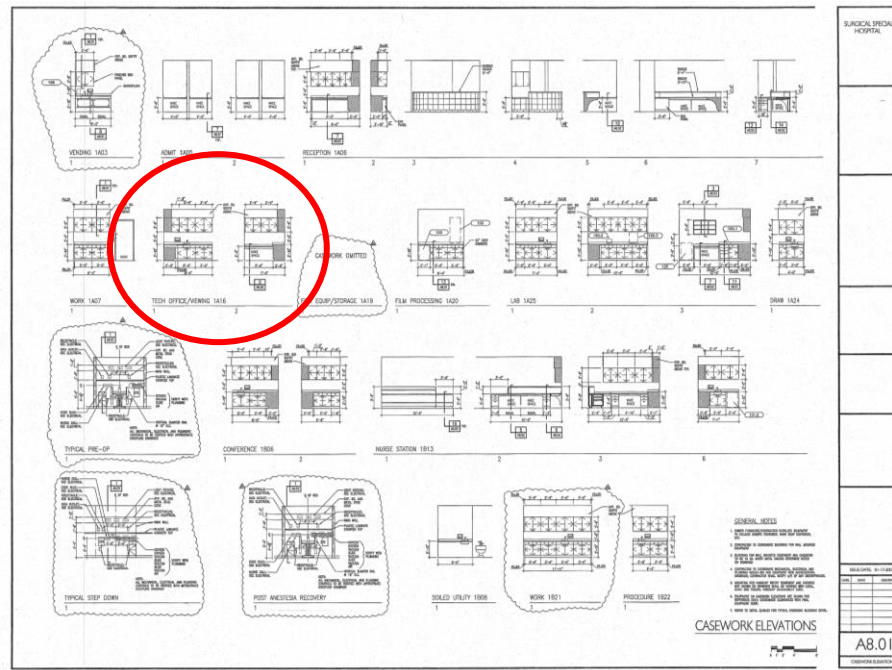

Now that you know where the interior elevation is, go to A8.01 and look for room 1A16. Look also for the dimensions.... And if there is any additional information

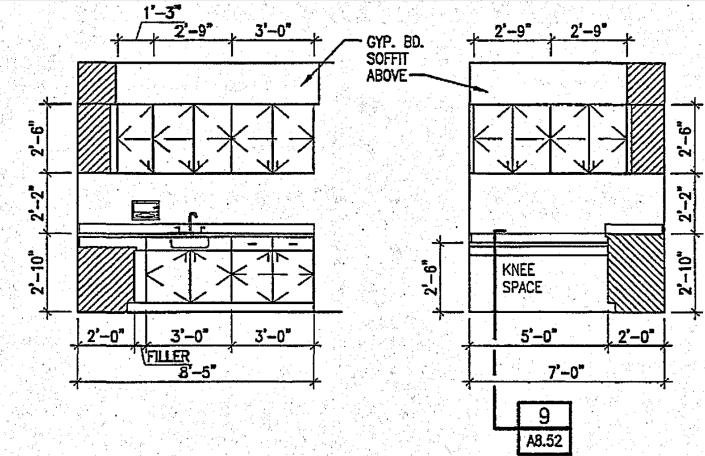

TECH OFFICE/VIEWING 1A16

1

2



What is the minimum clear Opening height for knee space at the countertop in Room 1A16?

2'-10" doesn't provide dimension for knee space

Look the indication for Knee Space. Is 2'-6" sufficient for response? Look detail 9/A8.52...

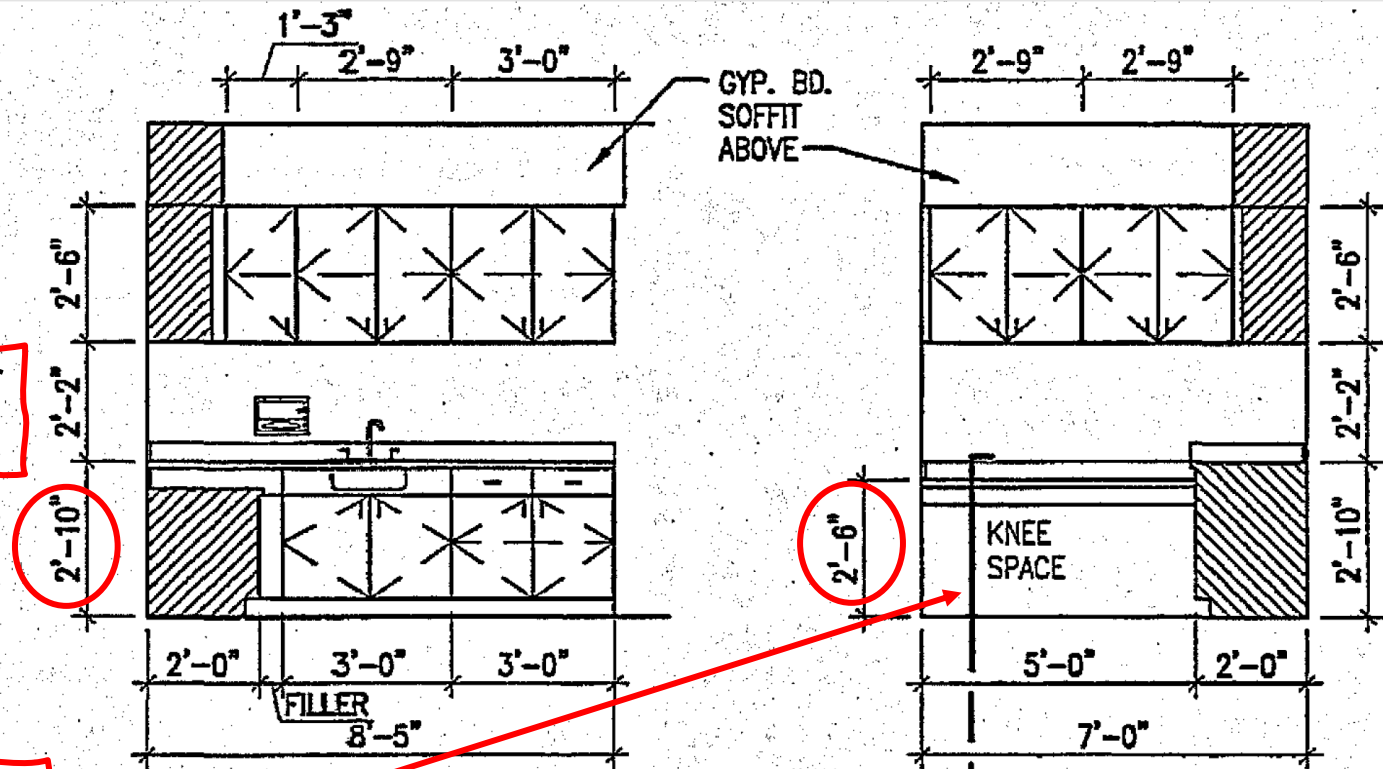

9
A8.52

TECH OFFICE/VIEWING 1A16

1

2



What is the minimum clear Opening height for knee space at the countertop in Room 1A16?

- A. 2' - 0 1/2"
- B. 2' - 6"
- C. 2' - 10"
- D. 5' - 0"



You need to consider, for the actual knee space, 2'-6" minus 5 1/2" of wood blocking

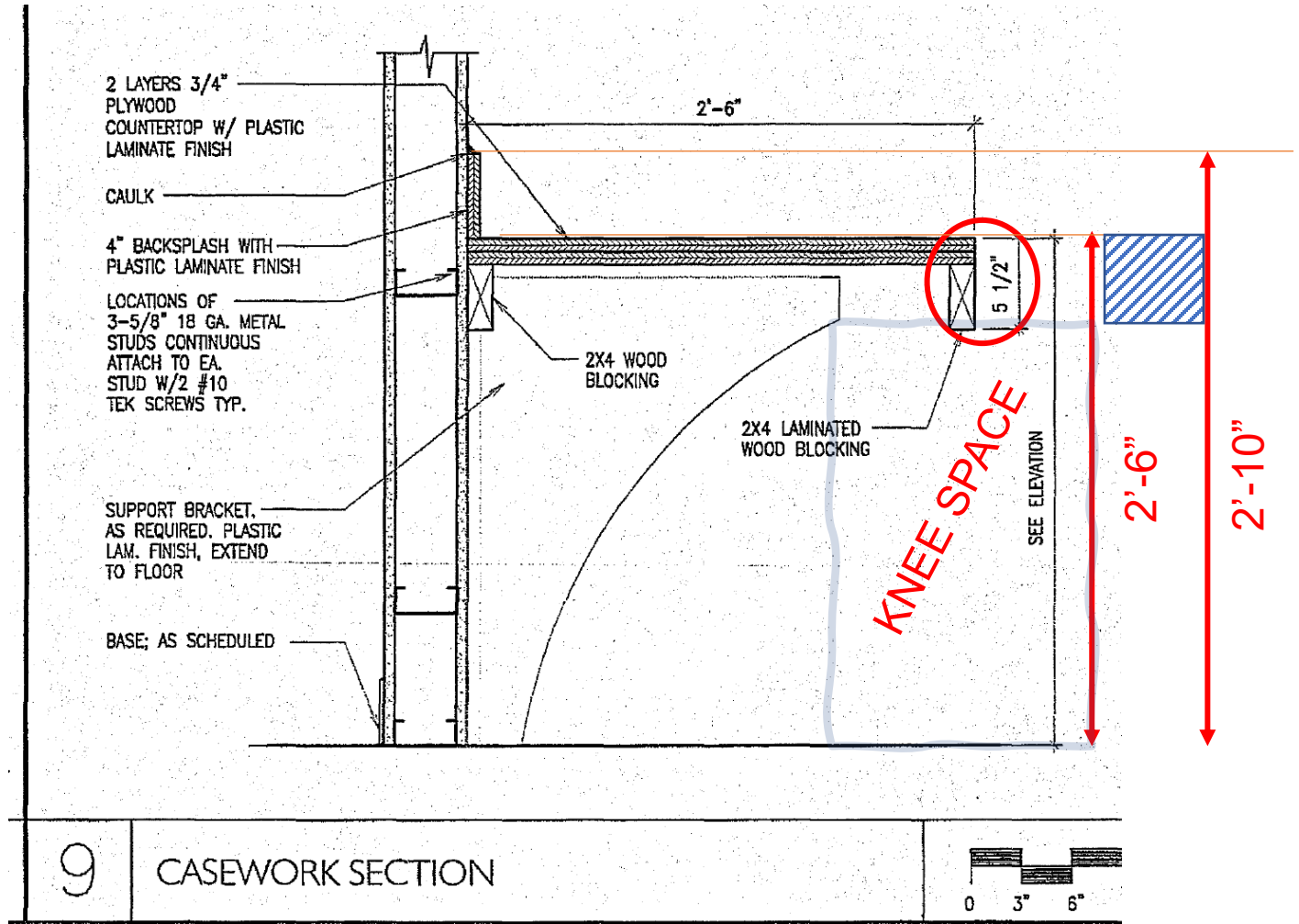

The floor finish for the operating room is _____.

What do you need to look for?
Finishes.

Go to Master Drawing Index and you will find Pattern Plans

- F2.01A PATTERN PLAN - 1ST FLOOR, PART A
- F2.01B PATTERN PLAN - 1ST FLOOR, PART B
- F2.02A PATTERN PLAN - 2ND FLOOR, PART A
- F2.02B PATTERN PLAN - 2ND FLOOR, PART B

The image shows a set of architectural drawing sheets. The 'MASTER DRAWING INDEX' sheet is highlighted with a red box, showing a grid of drawing titles and sheet numbers. A red box also highlights a specific entry in the index, likely corresponding to the floor finish information mentioned in the text.

The floor finish for the operating room is _____.

Then, you need to find the Operating Rooms.

You can navigate to any floor plans to find them.

For example, you could use the Pattern Plans.

And you will find them on F2.01B

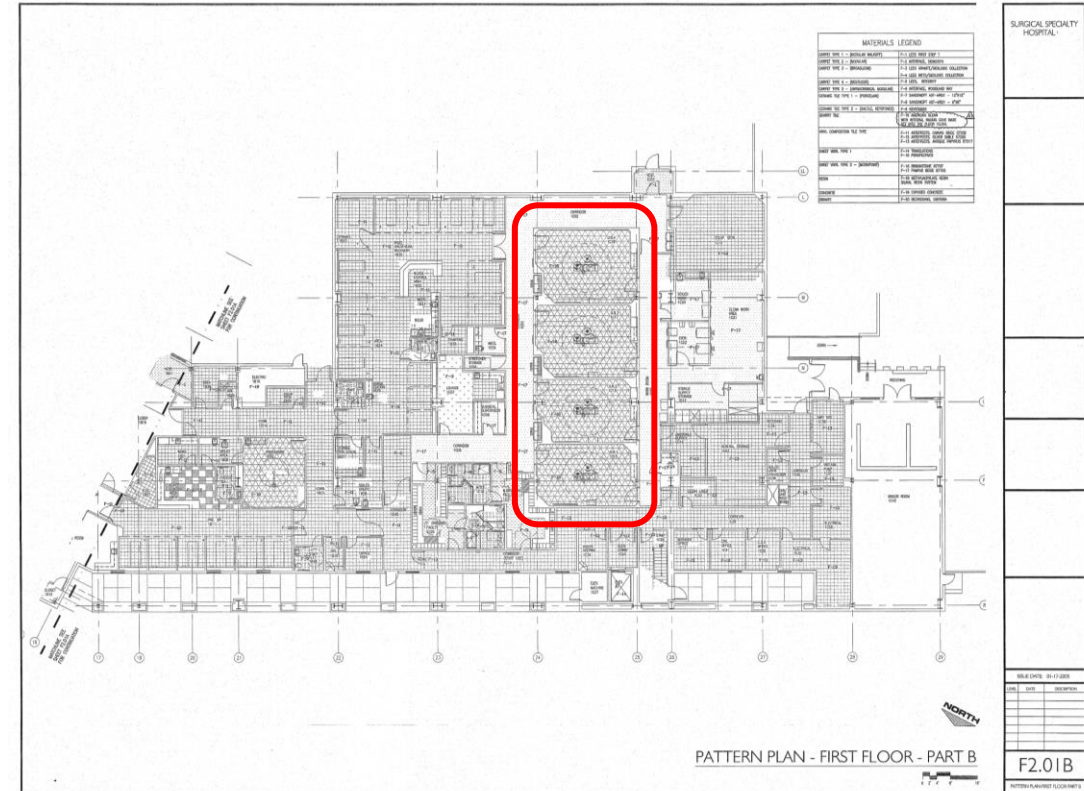
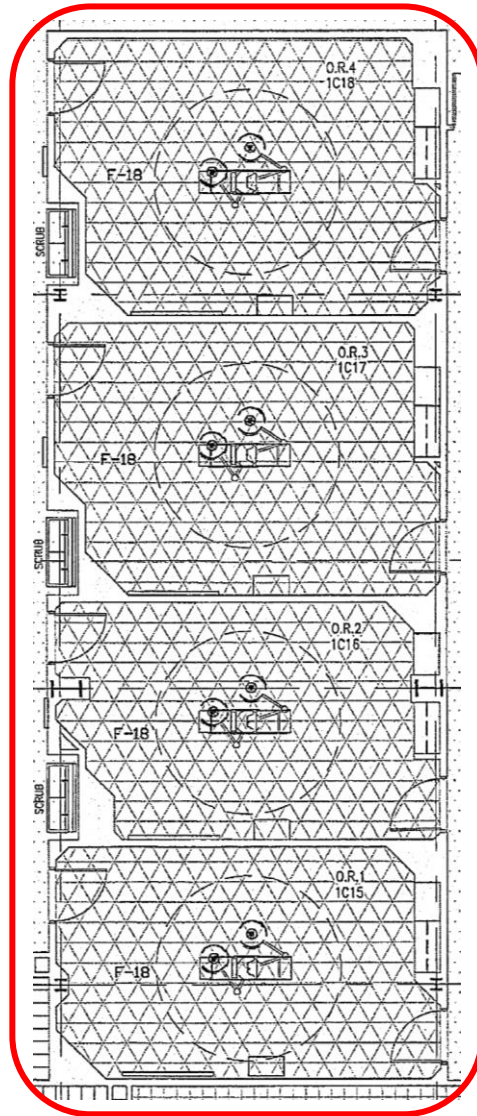

The floor finish for the operating room is _____.

In the same drawing, you can also find the Materials Legend

MATERIALS LEGEND	
CARPET TYPE 1 - (MODULAR WALKOFF)	F-1. LEES FIRST STEP T
CARPET TYPE 2 - (MODULAR)	F-2 INTERFACE, BIOMORPH
CARPET TYPE 3 - (BROADLOOM)	F-3 LEES GRANITE/GEOLOGIC COLLECTION F-4 LEES RIFTS/GEOLOGIC COLLECTION
CARPET TYPE 4 - (NEOFLOOR)	F-5 LEES, INTEGRITY
CARPET TYPE 5 - (ANTIMICROBIAL MODULAR)	F-6 INTERFACE, WOODLAND WAY
CERAMIC TILE TYPE 1 - (PORCELAIN)	F-7 SANDSWEPT AOT-MR21 - 12"X12" F-8 SANDSWEPT AOT-MR21 - 6"X6"
CERAMIC TILE TYPE 2 - (DAL TILE, KEYSTONES)	F-9 KEYSTONES
QUARRY TILE	F-10 AMERICAN OLEAN WITH INTEGRAL RADIUS COVE BASE SET INTO THE FLOOR FLUSH.
VINYL COMPOSITION TILE TYPE	F-11 ARTEFFECTS, CANVAS BEIGE 57202 F-12 ARTEFFECTS, SILVER SABLE 57205 F-13 ARTEFFECTS, ANTIQUE PAPHYRUS 57217
SHEET VINYL TYPE 1	F-14 TRANSLATIONS F-15 PERSPECTIVES
SHEET VINYL TYPE 2 - (MEDINPOINT)	F-16 BROOKSTONE 87707 F-17 PAMPAS BEIGE 87705
RESIN	F-18 METHYLACRYLATE RESIN SILKAL RESIN SYSTEM
CONCRETE	F-19 EXPOSED CONCRETE
GRANITE	F-20 BEDROSIANS, UBATUBA

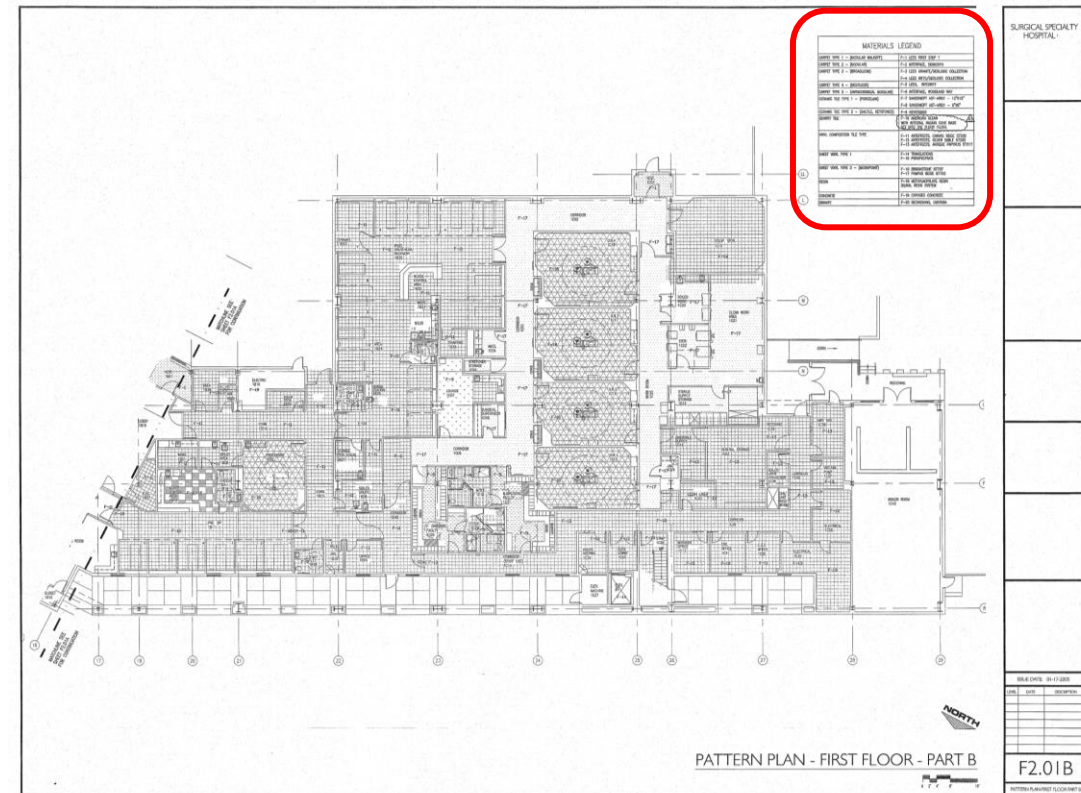

Structural



Example #1



Expansion tank ET-2 is anchored with:

- A. 8 – 3/8” dia. Red Head w/3-inch embedment
- B. 4 – 1/2” dia. Red head w/4-inch embedment
- C. 4 – 5/8” dia. Red Head w/6-inch embedment
- D. 6 – 3/4” dia. Red Head w/4-inch embedment

Look at the Equipment Seismic Chart...

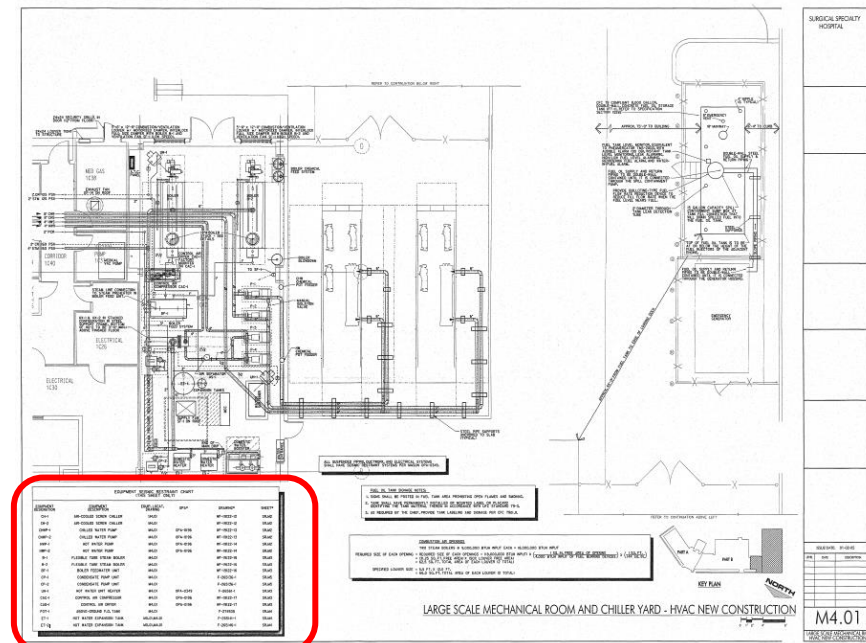

**EQUIPMENT SEISMIC RESTRAINT CHART
(THIS SHEET ONLY)**

EQUIPMENT DESIGNATION	EQUIPMENT DESCRIPTION	EQUIP. LOCAT. DRAWING	OPA*	DRAWING*	SHEET*
CH-1	AIR-COOLED SCREW CHILLER	M4.01		WF-19122-12	SR.M2
CH-2	AIR-COOLED SCREW CHILLER	M4.01		WF-19122-12	SR.M2
CHWP-1	CHILLED WATER PUMP	M4.01	OPA-0196	WF-19122-13	SR.M2
CHWP-2	CHILLED WATER PUMP	M4.01	OPA-0196	WF-19122-13	SR.M2
HWP-1	HOT WATER PUMP	M4.01	OPA-0196	WF-19122-14	SR.M2
HWP-2	HOT WATER PUMP	M4.01	OPA-0196	WF-19122-14	SR.M2
B-1	FLEXIBLE TUBE STEAM BOILER	M4.01		WF-19122-15	SR.M3
B-2	FLEXIBLE TUBE STEAM BOILER	M4.01		WF-19122-15	SR.M3
BF-1	BOILER FEEDWATER UNIT	M4.01		WF-19122-16	SR.M3
CP-1	CONDENSATE PUMP UNIT	M4.01		F-265136-1	SR.M5
CP-2	CONDENSATE PUMP UNIT	M4.01		F-265136-1	SR.M5
UH-1	HOT WATER UNIT HEATER	M4.01	OPA-0349	F-26561-1	SR.M3
CAC-1	CONTROL AIR COMPRESSOR	M4.01	OPA-0196	WF-19122-17	SR.M3
CAD-1	CONTROL AIR DRYER	M4.01	OPA-0196	WF-19122-17	SR.M3
FOT-1	ABOVE-GROUND F.O. TANK	M4.01		F-274535	SR.M4
ET-1	HOT WATER EXPANSION TANK	M0.01,M4.01		F-265141-1	SR.M4
ET-2	HOT WATER EXPANSION TANK	M0.01,M4.01		F-265146-1	SR.M4

Expansion tank ET-2 is anchored with:

- A. 8 – 3/8" dia. Red Head w/3-inch embedment
- B. 4 – 1/2" dia. Red head w/4-inch embedment ✓
- C. 4 – 5/8" dia. Red Head w/6-inch embedment
- D. 6 – 3/4" dia. Red Head w/4-inch embedment

Then go to the referenced sheet (SR.M4)

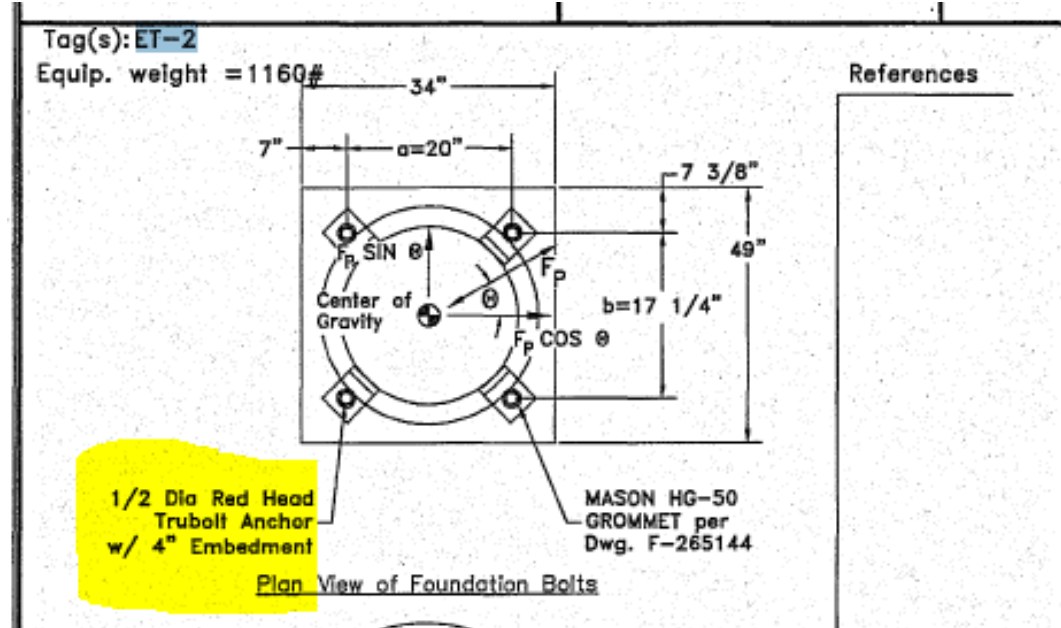
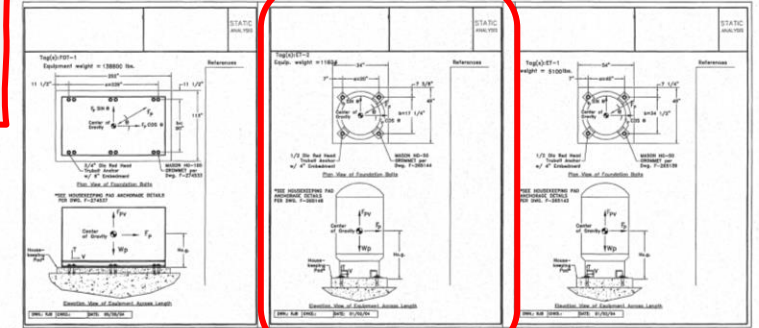

Example #2



How many bolts are required to attach the beam at the second floor along gridline M to the column at gridline 23?

2nd floor framing plan, look to grid line M and 23. Look also for detail 2/S4.1

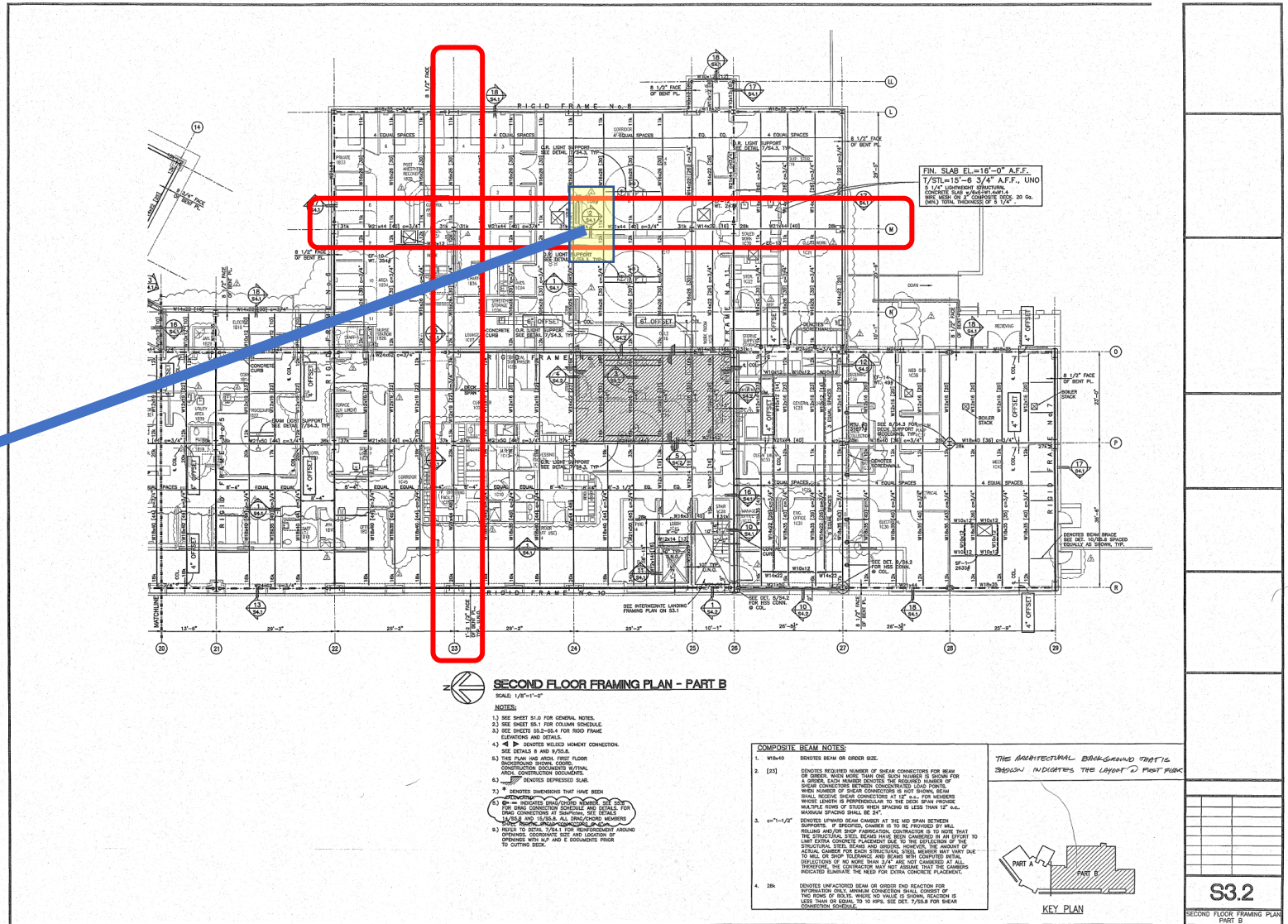
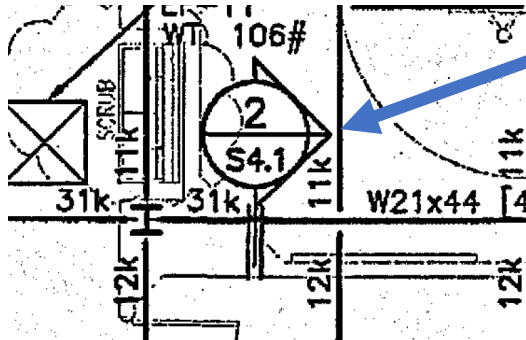

How many bolts are required to attach the beam at the second floor along gridline M to the column at gridline 23?

- A. 5
- B. 6 ✓
- C. 7
- D. 8

Detail 2/S4.1 refers to Beam schedule. The schedule is in Beam/column connection sheet, detail 7/S5.8

And remember the beam size from framing plan (W21)

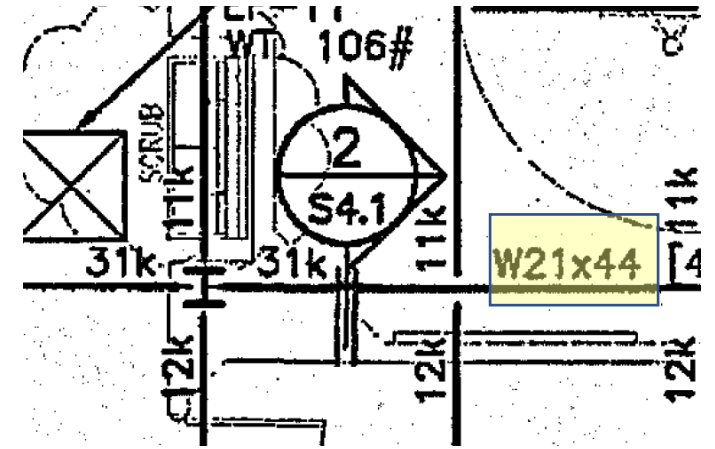

BEAM SHEAR CONNECTION SCHEDULE					
BEAM SIZE	SHEAR PLATE THICKNESS	B O L T S		WELD "A"	REMARKS
		NO.	DIA.		
W8	3/8"	2	3/4"	5/16"	
W10	3/8"	2	3/4"	5/16"	
W10x26	3/8"	2	1"	5/16"	
W12,W14	3/8"	3	3/4"	5/16"	
W16	3/8"	4	3/4"	5/16"	
W18	3/8"	5	3/4"	3/8"	
W21	1/2"	6	1"	3/8"	
W24,W27	1/2"	7	1"	3/8"	
W30	1/2"	8	1"	3/8"	
W33x	1/2"	9	1"	3/8"	
W36x	1/2"	10	1"	3/8"	

⑦ SHEAR CONNECTION SCHEDULE

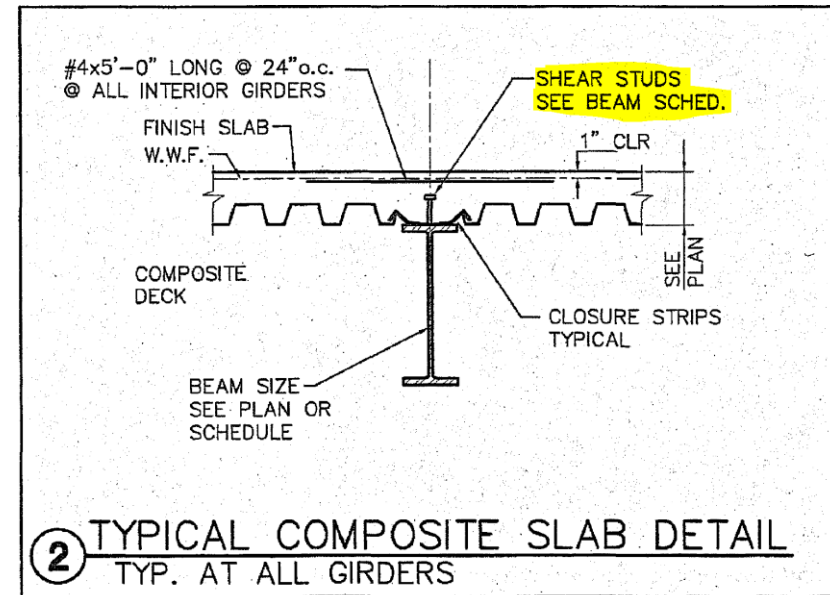

Example #3



Base plate size and thickness for column at the intersection of grid lines P and 27 is _____.

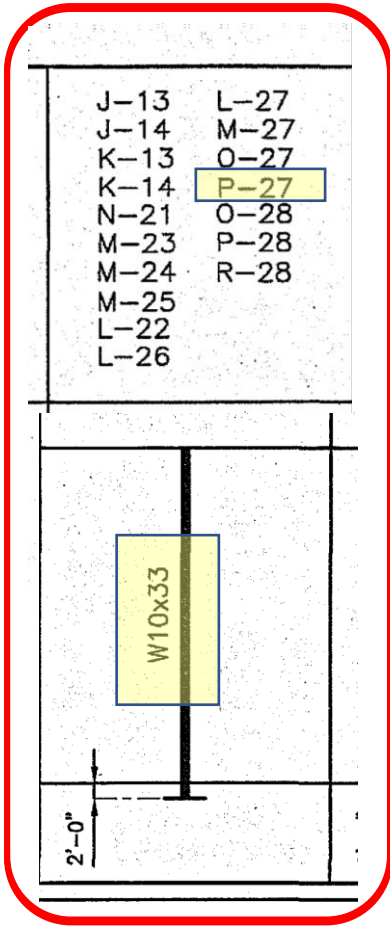

Look at the column schedule on S5.1, and find P-27.

After this, look for the column size

COLUMN SCHEDULE							BASE PLATE SCHEDULE			
COL. NO.	SECTION	SIZE	HEIGHT	THICKNESS	ANCHOR BOLTS	MARK	COL.	THK.	HT.	ANCHOR BOLTS
0-13.0	R-27	8-12	11'-0"	1/2"	4 3/4"					
1-13.0		8-12	11'-0"	1/2"	4 3/4"					
2-13.0		8-12	11'-0"	1/2"	4 3/4"					
3-13.0		8-12	11'-0"	1/2"	4 3/4"					
4-13.0		8-12	11'-0"	1/2"	4 3/4"					
5-13.0		8-12	11'-0"	1/2"	4 3/4"					
6-13.0		8-12	11'-0"	1/2"	4 3/4"					
7-13.0		8-12	11'-0"	1/2"	4 3/4"					
8-13.0		8-12	11'-0"	1/2"	4 3/4"					
9-13.0		8-12	11'-0"	1/2"	4 3/4"					
10-13.0		8-12	11'-0"	1/2"	4 3/4"					
11-13.0		8-12	11'-0"	1/2"	4 3/4"					
12-13.0		8-12	11'-0"	1/2"	4 3/4"					
13-13.0		8-12	11'-0"	1/2"	4 3/4"					
14-13.0		8-12	11'-0"	1/2"	4 3/4"					
15-13.0		8-12	11'-0"	1/2"	4 3/4"					
16-13.0		8-12	11'-0"	1/2"	4 3/4"					
17-13.0		8-12	11'-0"	1/2"	4 3/4"					
18-13.0		8-12	11'-0"	1/2"	4 3/4"					
19-13.0		8-12	11'-0"	1/2"	4 3/4"					
20-13.0		8-12	11'-0"	1/2"	4 3/4"					
21-13.0		8-12	11'-0"	1/2"	4 3/4"					
22-13.0		8-12	11'-0"	1/2"	4 3/4"					
23-13.0		8-12	11'-0"	1/2"	4 3/4"					
24-13.0		8-12	11'-0"	1/2"	4 3/4"					
25-13.0		8-12	11'-0"	1/2"	4 3/4"					
26-13.0		8-12	11'-0"	1/2"	4 3/4"					
27-13.0		8-12	11'-0"	1/2"	4 3/4"					
28-13.0		8-12	11'-0"	1/2"	4 3/4"					
29-13.0		8-12	11'-0"	1/2"	4 3/4"					
30-13.0		8-12	11'-0"	1/2"	4 3/4"					
31-13.0		8-12	11'-0"	1/2"	4 3/4"					
32-13.0		8-12	11'-0"	1/2"	4 3/4"					
33-13.0		8-12	11'-0"	1/2"	4 3/4"					
34-13.0		8-12	11'-0"	1/2"	4 3/4"					
35-13.0		8-12	11'-0"	1/2"	4 3/4"					
36-13.0		8-12	11'-0"	1/2"	4 3/4"					
37-13.0		8-12	11'-0"	1/2"	4 3/4"					
38-13.0		8-12	11'-0"	1/2"	4 3/4"					
39-13.0		8-12	11'-0"	1/2"	4 3/4"					
40-13.0		8-12	11'-0"	1/2"	4 3/4"					
41-13.0		8-12	11'-0"	1/2"	4 3/4"					
42-13.0		8-12	11'-0"	1/2"	4 3/4"					
43-13.0		8-12	11'-0"	1/2"	4 3/4"					
44-13.0		8-12	11'-0"	1/2"	4 3/4"					
45-13.0		8-12	11'-0"	1/2"	4 3/4"					
46-13.0		8-12	11'-0"	1/2"	4 3/4"					
47-13.0		8-12	11'-0"	1/2"	4 3/4"					
48-13.0		8-12	11'-0"	1/2"	4 3/4"					
49-13.0		8-12	11'-0"	1/2"	4 3/4"					
50-13.0		8-12	11'-0"	1/2"	4 3/4"					
51-13.0		8-12	11'-0"	1/2"	4 3/4"					
52-13.0		8-12	11'-0"	1/2"	4 3/4"					
53-13.0		8-12	11'-0"	1/2"	4 3/4"					
54-13.0		8-12	11'-0"	1/2"	4 3/4"					
55-13.0		8-12	11'-0"	1/2"	4 3/4"					
56-13.0		8-12	11'-0"	1/2"	4 3/4"					
57-13.0		8-12	11'-0"	1/2"	4 3/4"					
58-13.0		8-12	11'-0"	1/2"	4 3/4"					
59-13.0		8-12	11'-0"	1/2"	4 3/4"					
60-13.0		8-12	11'-0"	1/2"	4 3/4"					
61-13.0		8-12	11'-0"	1/2"	4 3/4"					
62-13.0		8-12	11'-0"	1/2"	4 3/4"					
63-13.0		8-12	11'-0"	1/2"	4 3/4"					
64-13.0		8-12	11'-0"	1/2"	4 3/4"					
65-13.0		8-12	11'-0"	1/2"	4 3/4"					
66-13.0		8-12	11'-0"	1/2"	4 3/4"					
67-13.0		8-12	11'-0"	1/2"	4 3/4"					
68-13.0		8-12	11'-0"	1/2"	4 3/4"					
69-13.0		8-12	11'-0"	1/2"	4 3/4"					
70-13.0		8-12	11'-0"	1/2"	4 3/4"					
71-13.0		8-12	11'-0"	1/2"	4 3/4"					
72-13.0		8-12	11'-0"	1/2"	4 3/4"					
73-13.0		8-12	11'-0"	1/2"	4 3/4"					
74-13.0		8-12	11'-0"	1/2"	4 3/4"					
75-13.0		8-12	11'-0"	1/2"	4 3/4"					
76-13.0		8-12	11'-0"	1/2"	4 3/4"					
77-13.0		8-12	11'-0"	1/2"	4 3/4"					
78-13.0		8-12	11'-0"	1/2"	4 3/4"					
79-13.0		8-12	11'-0"	1/2"	4 3/4"					
80-13.0		8-12	11'-0"	1/2"	4 3/4"					
81-13.0		8-12	11'-0"	1/2"	4 3/4"					
82-13.0		8-12	11'-0"	1/2"	4 3/4"					
83-13.0		8-12	11'-0"	1/2"	4 3/4"					
84-13.0		8-12	11'-0"	1/2"	4 3/4"					
85-13.0		8-12	11'-0"	1/2"	4 3/4"					
86-13.0		8-12	11'-0"	1/2"	4 3/4"					
87-13.0		8-12	11'-0"	1/2"	4 3/4"					
88-13.0		8-12	11'-0"	1/2"	4 3/4"					
89-13.0		8-12	11'-0"	1/2"	4 3/4"					
90-13.0		8-12	11'-0"	1/2"	4 3/4"					
91-13.0		8-12	11'-0"	1/2"	4 3/4"					
92-13.0		8-12	11'-0"	1/2"	4 3/4"					
93-13.0		8-12	11'-0"	1/2"	4 3/4"					
94-13.0		8-12	11'-0"	1/2"	4 3/4"					
95-13.0		8-12	11'-0"	1/2"	4 3/4"					
96-13.0		8-12	11'-0"	1/2"	4 3/4"					
97-13.0		8-12	11'-0"	1/2"	4 3/4"					
98-13.0		8-12	11'-0"	1/2"	4 3/4"					
99-13.0		8-12	11'-0"	1/2"	4 3/4"					
100-13.0		8-12	11'-0"	1/2"	4 3/4"					

ISSUE DATE: 11-03-2005

NO.	DATE	DESCRIPTION

S5.1
SHIRTS, COLUMNS, SCHEDULES & DETAILS

Base plate size and thickness for column at the intersection of grid lines P and 27 is _____.

- A. 18" x 18" x 1" ✓
- B. 18" x 18" x 1¼"
- C. 20" x 20" x 1"
- D. 20" x 20" x 1½"

In the same sheet, look for the Base Plate Schedule to find the answer for W10x23

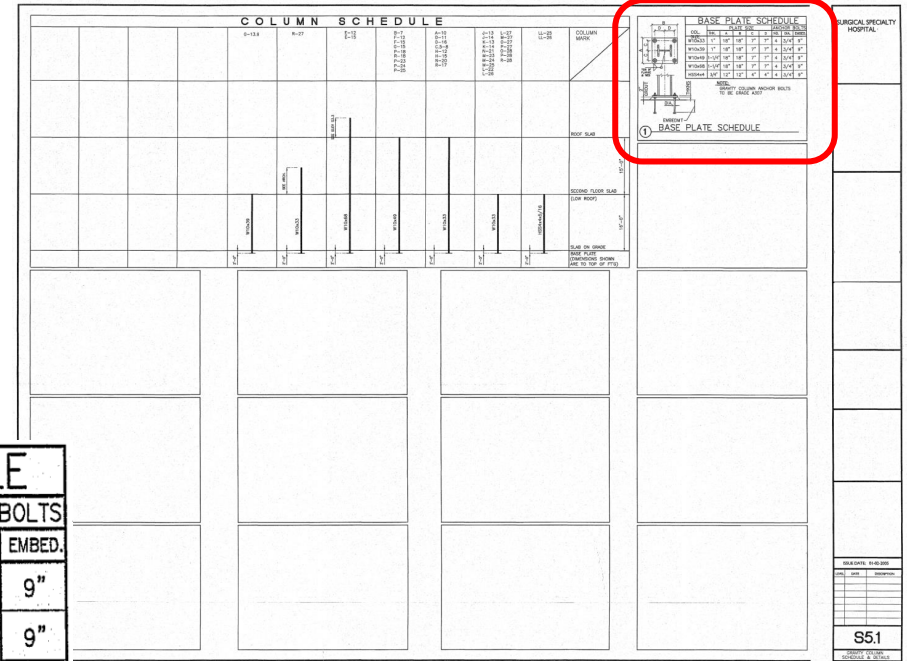

COL. SIZE	PLATE SIZE				ANCHOR BOLTS			
	THK.	A	B	C	D	NO.	DIA.	EMBED.
W10x33	1"	18"	18"	7"	7"	4	3/4"	9"
W10x39	1"	18"	18"	7"	7"	4	3/4"	9"
W10x49	1-1/4"	18"	18"	7"	7"	4	3/4"	9"
W10x68	1-1/4"	18"	18"	7"	7"	4	3/4"	9"
HSS4x4	3/4"	12"	12"	4"	4"	4	3/4"	9"

NOTE:
GRAVITY COLUMN ANCHOR BOLTS TO BE GRADE A307

1 BASE PLATE SCHEDULE



Example #4



The kitchen equipment is anchored to what type of concrete?

First, look the Food Service Equipment Schedule, and see references for seismic detail.

You will see references from SRA6-10.

SCHEDULE OF EQUIPMENT				
ITEM	DESCRIPTION	SEISMIC DETAILS (DETAIL #/SHEET)	OPA APPROVAL	REMARKS
1	TRASH RECEPTACLE	--	--	BY OWNER
2	HAND SINK	--	--	BY PLUMBING CONTRACTOR
3	SINK W/ DISPOSABLE	F-278155/SRA6, F-278157/SRA6	--	W/ PRE-RINSE
4	DISPOSER W/ CONTROL	--	--	--
5	RACK SHELF	F-278165/SRA10	--	--
6	DISH MACHINE	F-278156/SRA6, F-278158/SRA6	--	--
7	CONDENSATE HOOD	F-27778/SRA6, F-27779/SRA6, F-27780/SRA6, F-27781/SRA6	R-0349	--
8	RACK SHELF	F-278165/SRA10	--	--
9	SPARE NUMBER	--	--	--
10	SPARE NUMBER	--	--	--
11	BOOSTER HEATER	F-278155/SRA6, 278159/SRA6	--	--
12	CLEAN DIGITABLE	F-278155/SRA6, F-278160/SRA6	--	--
13	MOBILE CUP/GLASS RACK DOLLY	--	--	--
14	S/S CORNER GUARD	--	--	--
15	SMART WALL ASSEMBLY	F-277780/SRA6	--	--
16	3-COMPARTMENT SINK	F-278164/SRA6, F-278166/SRA6, F-278167/SRA6	--	--
17	SMART WALL ASSEMBLY	F-277780/SRA6	--	--
18	FLOOR TROUGH W/ GRATE	--	--	--
19	SPARE NUMBER	--	--	--
20	SPARE NUMBER	--	--	--
21	FIRE SUPPRESSION SYSTEM	F-277293/SRA7	--	--
22	COFFEE BREWER	--	--	BY VENDOR
23	ICED TEA BREWER	--	--	BY VENDOR
24	TOASTER	--	--	--
25	BEVERAGE COUNTER	F-278155/SRA6, F-278161/SRA6	--	--
26	SMART WALL ASSEMBLY	F-277780/SRA6	--	--
27	MOBILE 3-WELL HOT FOOD TABLE	--	--	--
28	MOBILE TRAY TRANSPORT CART	--	--	--
29	SPARE NUMBER	--	--	--
30	SPARE NUMBER	--	--	--
31	MOBILE HOT BOX / PROOFER	--	--	--
32	S/S WALL FLASHING	F-277284/SRA6, F-277285/SRA6, F-277286/SRA6, F-277287/SRA6	R-0349	--
33	EXHAUST VENTILATOR	F-277288/SRA7	--	--
34	STREAMER	F-277288/SRA7	--	--
35	COMBINATION RANGE/GRIDDLE	F-277289/SRA7	--	--
36	FRYER/FLEISHER UNIT	F-277289/SRA7	--	--
37	REACH-IN FREEZER	F-277308/SRA7	--	--
38	REACH-IN REFRIGERATOR	F-277308/SRA7	--	--
39	SPARE NUMBER	--	--	--
40	SPARE NUMBER	--	--	--
41	REACH-IN FREEZER	F-277308/SRA7	--	--
42	SMART WALL ASSEMBLY	F-277780/SRA6	--	--
43	OFFICE FURNITURE	--	--	BY OWNER
44	STORAGE SHELVING	F-277783/SRA6	--	--
45	DUNNAGE SHELF	--	--	--
46	TABLE MOUNTED CAN OPENER	--	--	--
47	TRASH RECEPTACLE	--	--	BY OWNER
48	SMART WALL ASSEMBLY	F-277780/SRA6	--	--
49	SPARE NUMBER	--	--	--
50	SPARE NUMBER	--	--	--
51	PREPARATION TABLE W/ SINKS	F-278174/SRA6, F-178175/SRA6	--	--
52	DISPOSER W/ CONTROL	--	--	--
53	FOOD PROCESSOR	--	--	--
54	MOBILE INGREDIENT BINS	--	--	--
55	SLICER	--	--	--
56	ICE MAKER W/ FILTER	F-277301/SRA7	--	--
57	ICE BIN	F-277301/SRA7	--	--
58	MOP SINK	--	--	BY PLUMBING CONTRACTOR
59	WALL SHELF	F-278179/SRA6	--	--
60	MOP RACK	--	--	BY PLUMBING CONTRACTOR
61	MOBILE POT/PAN RACK	--	--	--
62	HOSE REEL	--	--	BY PLUMBING CONTRACTOR
63	PREP TABLE	F-278170/SRA6, F-278172/SRA6	--	--
64	SMART WALL ASSEMBLY	F-277780/SRA6	--	--

GENERAL NOTES

1. ALL EQUIPMENT SHALL BE ANCHORED TO THE CONCRETE FLOOR OR WALLS AS SHOWN ON THE SEISMIC DETAILS. THE CONTRACTOR SHALL VERIFY THE SEISMIC DETAILS AND THE ANCHORING METHOD WITH THE PLUMBING CONTRACTOR AND THE OWNER'S REPRESENTATIVE.

2. THE CONTRACTOR SHALL VERIFY THE SEISMIC DETAILS AND THE ANCHORING METHOD WITH THE PLUMBING CONTRACTOR AND THE OWNER'S REPRESENTATIVE.

3. THE CONTRACTOR SHALL VERIFY THE SEISMIC DETAILS AND THE ANCHORING METHOD WITH THE PLUMBING CONTRACTOR AND THE OWNER'S REPRESENTATIVE.

SCHEDULE OF EQUIPMENT

ITEM	DESCRIPTION	SEISMIC DETAILS (DETAIL #/SHEET)	OPA APPROVAL	REMARKS
1	TRASH RECEPTACLE	--	--	BY OWNER
2	HAND SINK	--	--	BY PLUMBING CONTRACTOR
3	SINK W/ DISPOSABLE	F-278155/SRA6, F-278157/SRA6	--	W/ PRE-RINSE
4	DISPOSER W/ CONTROL	--	--	--
5	RACK SHELF	F-278165/SRA10	--	--
6	DISH MACHINE	F-278156/SRA6, F-278158/SRA6	--	--
7	CONDENSATE HOOD	F-27778/SRA6, F-27779/SRA6, F-27780/SRA6, F-27781/SRA6	R-0349	--
8	RACK SHELF	F-278165/SRA10	--	--
9	SPARE NUMBER	--	--	--
10	SPARE NUMBER	--	--	--
11	BOOSTER HEATER	F-278155/SRA6, 278159/SRA6	--	--
12	CLEAN DIGITABLE	F-278155/SRA6, F-278160/SRA6	--	--
13	MOBILE CUP/GLASS RACK DOLLY	--	--	--
14	S/S CORNER GUARD	--	--	--
15	SMART WALL ASSEMBLY	F-277780/SRA6	--	--
16	3-COMPARTMENT SINK	F-278164/SRA6, F-278166/SRA6, F-278167/SRA6	--	--
17	SMART WALL ASSEMBLY	F-277780/SRA6	--	--
18	FLOOR TROUGH W/ GRATE	--	--	--
19	SPARE NUMBER	--	--	--
20	SPARE NUMBER	--	--	--
21	FIRE SUPPRESSION SYSTEM	F-277293/SRA7	--	--
22	COFFEE BREWER	--	--	BY VENDOR
23	ICED TEA BREWER	--	--	BY VENDOR
24	TOASTER	--	--	--
25	BEVERAGE COUNTER	F-278155/SRA6, F-278161/SRA6	--	--
26	SMART WALL ASSEMBLY	F-277780/SRA6	--	--
27	MOBILE 3-WELL HOT FOOD TABLE	--	--	--
28	MOBILE TRAY TRANSPORT CART	--	--	--
29	SPARE NUMBER	--	--	--
30	SPARE NUMBER	--	--	--
31	MOBILE HOT BOX / PROOFER	--	--	--
32	S/S WALL FLASHING	F-277284/SRA6, F-277285/SRA6, F-277286/SRA6, F-277287/SRA6	R-0349	--
33	EXHAUST VENTILATOR	F-277288/SRA7	--	--
34	STREAMER	F-277288/SRA7	--	--
35	COMBINATION RANGE/GRIDDLE	F-277289/SRA7	--	--
36	FRYER/FLEISHER UNIT	F-277289/SRA7	--	--
37	REACH-IN FREEZER	F-277308/SRA7	--	--
38	REACH-IN REFRIGERATOR	F-277308/SRA7	--	--
39	SPARE NUMBER	--	--	--
40	SPARE NUMBER	--	--	--
41	REACH-IN FREEZER	F-277308/SRA7	--	--
42	SMART WALL ASSEMBLY	F-277780/SRA6	--	--
43	OFFICE FURNITURE	--	--	BY OWNER
44	STORAGE SHELVING	F-277783/SRA6	--	--
45	DUNNAGE SHELF	--	--	--
46	TABLE MOUNTED CAN OPENER	--	--	--
47	TRASH RECEPTACLE	--	--	BY OWNER
48	SMART WALL ASSEMBLY	F-277780/SRA6	--	--
49	SPARE NUMBER	--	--	--
50	SPARE NUMBER	--	--	--
51	PREPARATION TABLE W/ SINKS	F-278174/SRA6, F-178175/SRA6	--	--
52	DISPOSER W/ CONTROL	--	--	--
53	FOOD PROCESSOR	--	--	--
54	MOBILE INGREDIENT BINS	--	--	--
55	SLICER	--	--	--
56	ICE MAKER W/ FILTER	F-277301/SRA7	--	--
57	ICE BIN	F-277301/SRA7	--	--
58	MOP SINK	--	--	BY PLUMBING CONTRACTOR
59	WALL SHELF	F-278179/SRA6	--	--
60	MOP RACK	--	--	BY PLUMBING CONTRACTOR
61	MOBILE POT/PAN RACK	--	--	--
62	HOSE REEL	--	--	BY PLUMBING CONTRACTOR
63	PREP TABLE	F-278170/SRA6, F-278172/SRA6	--	--
64	SMART WALL ASSEMBLY	F-277780/SRA6	--	--

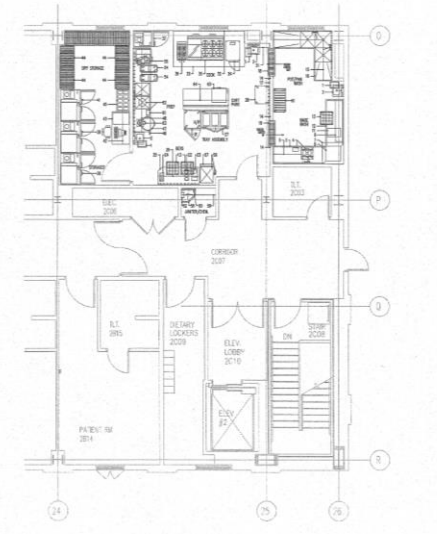

NOTE: THIS DRAWING INDICATES THE GENERAL EXTENT OF WORK AND IS NOT INTENDED TO INDICATE OR DESCRIBE ALL WORK REQUIRED FOR THE FULL PERFORMANCE AND COMPLETION OF THE REQUIREMENTS OF THE CONTRACT DOCUMENTS.

SCALE: 1/4" = 1'-0"

KITCHEN EQUIPMENT LAYOUT

DATE: 11/1/2005
BY: J. J. J.
CHECKED: J. J. J.
APPROVED: J. J. J.
PROJECT: FS. I.
WORK: 00000000

The kitchen equipment is anchored to what type of concrete?

Let's look at them from SRA6-10 and see the one anchored.

The equipment anchored are on SRA7-9

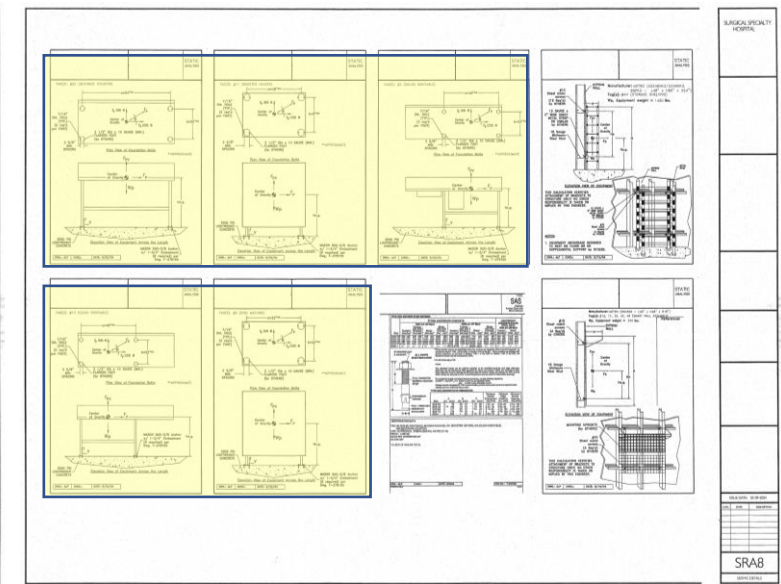
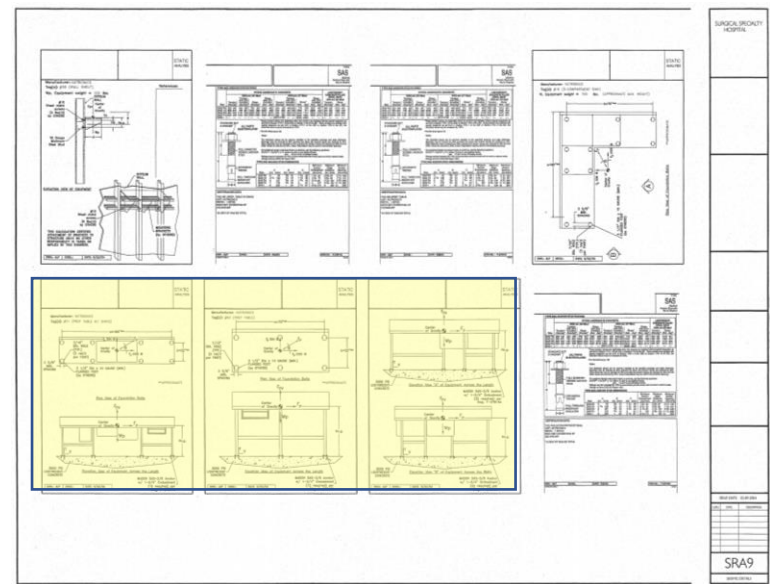
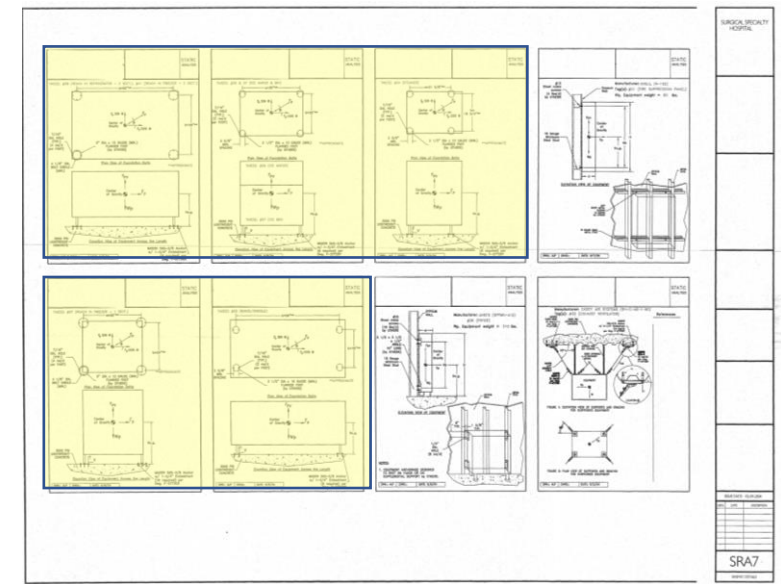

The kitchen equipment is anchored to what type of concrete?

- A. 3,000 psi
- B. 3,000 psi, lightweight ✓
- C. 4,000 psi
- D. 4,000 psi, lightweight

Let's look at them from SRA6-10 and see the one anchored.

The equipment anchored are on SRA7-9

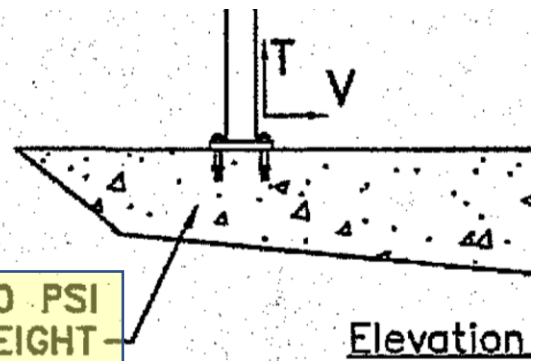

Example #5



Hot water recirculation pumps HWRP-1 and HWRP-2 are:

First of all, look into the Plumbing sheet for the pump seismic restraint chart

EQUIPMENT SEISMIC RESTRAINT CHART (THIS SHEET ONLY)					
EQUIPMENT DESIGNATION	EQUIPMENT DESCRIPTION	EQUIP. LOCAT. DRAWING	OPA#	DRAWING#	SHEET#
WH-1	WATER HEATER	P3.01		WF-19122-18	SR,PI
WH-2	WATER HEATER	P3.01		WF-19122-18	SR,PI
HWRP-1	HOT WATER RECIR PUMP	P3.01	OPA-0349	WF-19122-28	SR,PI
HWRP-2	HOT WATER RECIR PUMP	P3.01	OPA-0349	WF-19122-28	SR,PI
BP-1	BOOSTER PUMP	P3.01		WF-19122-19	SR,PI
WSF-1	WATER SOFTNER	P3.01		WF-19122-20	SR,PI
MVP-1	MEDICAL VACUUM PUMP	P2.02		F-265170-1	SR,PI
AIR	AIR MANIFOLD	P2.02		F-265170-1	SR,PI
NITROUS	NITROUS MANIFOLD	P2.02		F-265170-1	SR,PI
NITROGEN	NITROGEN MANIFOLD	P2.02		F-265170-1	SR,PI
OXYGEN	OXYGEN MANIFOLD	P2.02		F-265170-1	SR,PI

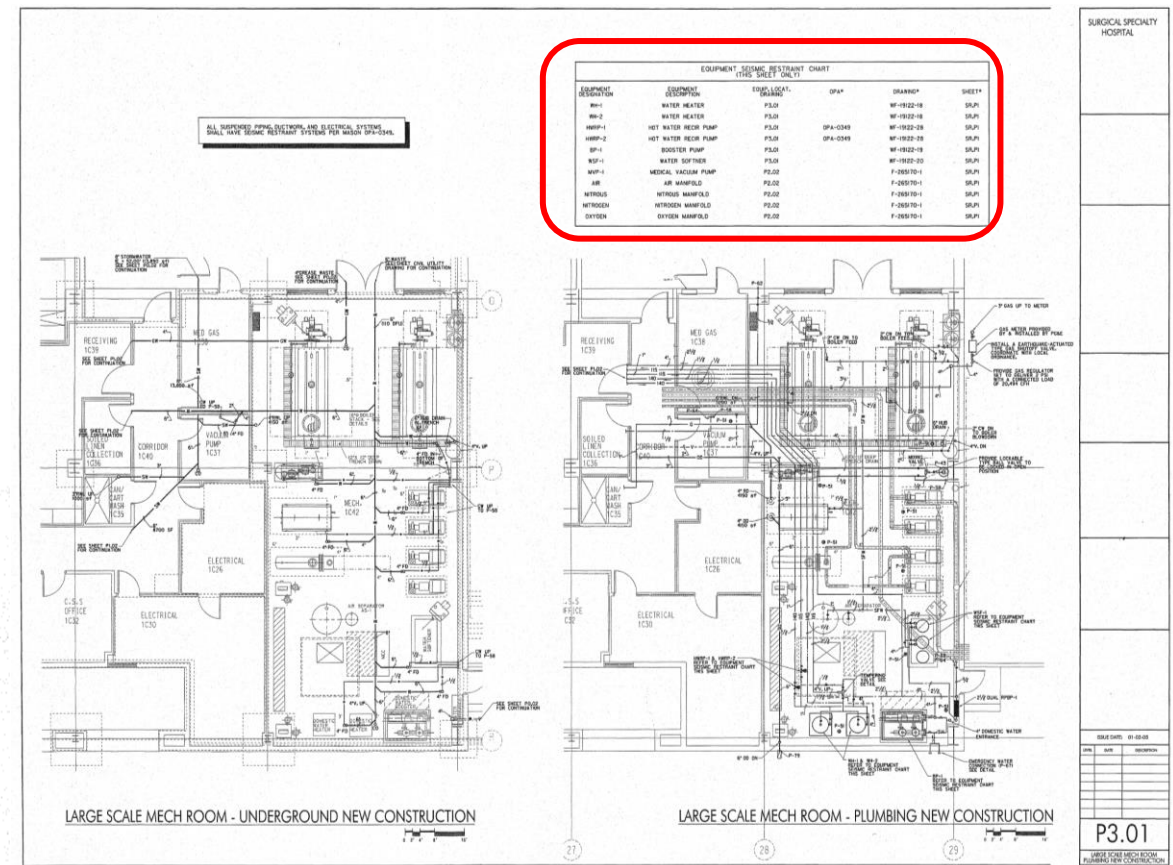

Hot water recirculation pumps HWRP-1 and HWRP-2 are:

- A. Mounted on housekeeping slabs
- B. Mounted on pedestals
- C. **Suspended from the deck** ✓
- D. Wall mounted

Go to SR.P1, and look for WF-19122-28

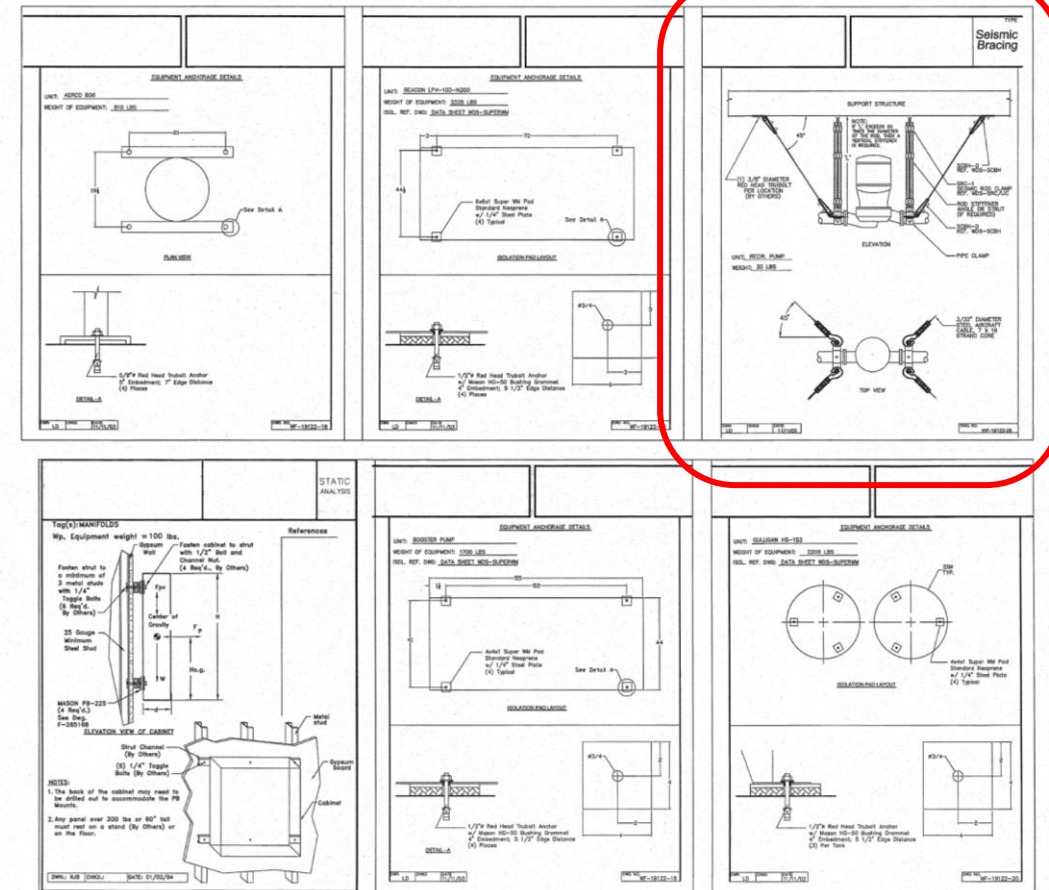
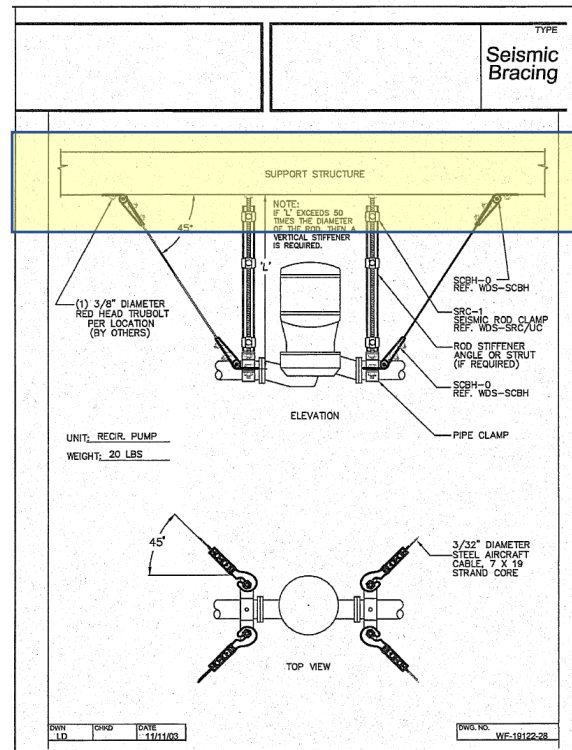

Homework

Homework #1

What reinforcing steel is required for the footing at the intersection of grid lines O and 23?

- A. 4 - #4 Bottom
- B. 6 - #6 Bottom
- C. 10 - #6 Bottom
- D. 9 - #6 Top & Bottom
- E. 13 - #7 Top & Bottom

Homework #2

The typical header for a 10-foot clear opening in the exterior wall would be:

- A. 2- 6"x18ga. studs with 3- 6"x14ga. Tracks
- B. 1- 6"x18ga. stud with 2- 6"x18ga. Tracks
- C. 3- 6"x14ga. studs with 3- 6"x 14ga. Tracks
- D. 2- 6"x18ga. studs with 2- 6"x18ga. tracks



The floor finish for the operating room is _____.

- A. Carpet
- B. sheet vinyl
- C. resin
- D. none of the above

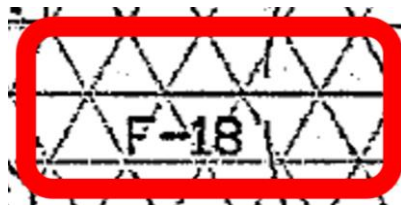

RESIN	F-18 METHYLACRYLATE RESIN SILKAL RESIN SYSTEM
-------	--

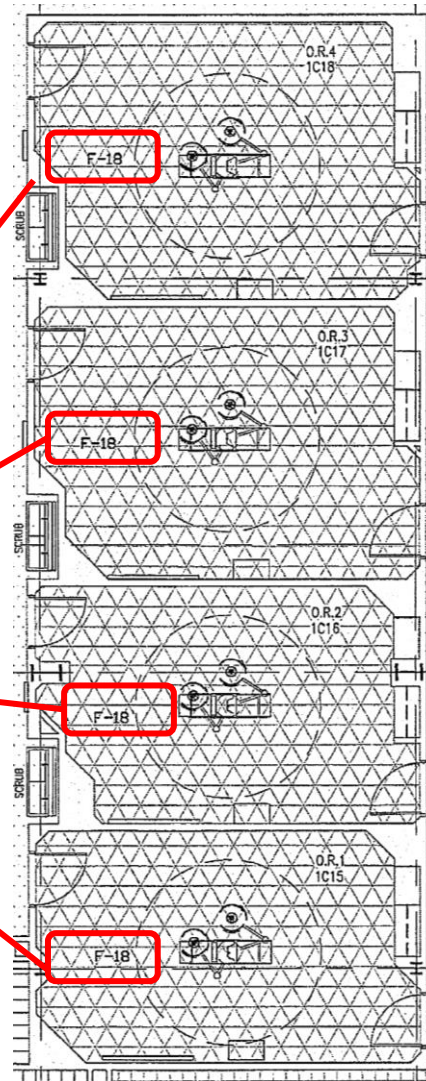

MATERIALS LEGEND	
CARPET TYPE 1 - (MODULAR WALKOFF)	F-1 LEES FIRST STEP T
CARPET TYPE 2 - (MODULAR)	F-2 INTERFACE, BIOMORPH
CARPET TYPE 3 - (BROADLOOM)	F-3 LEES GRANITE/GEOLOGIC COLLECTION
	F-4 LEES RIFTS/GEOLOGIC COLLECTION
CARPET TYPE 4 - (MEDFLOOR)	F-5 LEES, INTEGRITY
CARPET TYPE 5 - (ANTIMICROBIAL MODULAR)	F-6 INTERFACE, WOODLAND WAY
CERAMIC TILE TYPE 1 - (PORCELAIN)	F-7 SANDSWEEP AOT-MR21 - 12"X12"
	F-8 SANDSWEEP AOT-MR21 - 6"X6"
CERAMIC TILE TYPE 2 - (DALTILE, KEYSTONES)	F-9 KEYSTONES
QUARRY TILE	F-10 AMERICAN OLEAN WITH INTEGRAL RADIUS COVE BASE SET INTO THE FLOOR FLUSH.
VINYL COMPOSITION TILE TYPE	F-11 ARTEFFECTS, CANVAS BEIGE 57202
	F-12 ARTEFFECTS, SILVER SABLE 57205
	F-13 ARTEFFECTS, ANTIQUE PAPYRUS 57217
SHEET VINYL TYPE 1	F-14 TRANSLATIONS
	F-15 PERSPECTIVES
SHEET VINYL TYPE 2 - (MEDINPOINT)	F-16 BROOKSTONE 87707
	F-17 BAMPAS BEIGE 87705
RESIN	F-18 METHYLACRYLATE RESIN SILKAL RESIN SYSTEM
CONCRETE	F-19 EXPOSED CONCRETE
GRANITE	F-20 BEDROSIANS, UBATUBA



Structural



Example #1



Expansion tank ET-2 is anchored with:

- A. 8 – 3/8” dia. Red Head w/3-inch embedment
- B. 4 – 1/2” dia. Red head w/4-inch embedment
- C. 4 – 5/8” dia. Red Head w/6-inch embedment
- D. 6 – 3/4” dia. Red Head w/4-inch embedment

Look at the Equipment Seismic Chart...

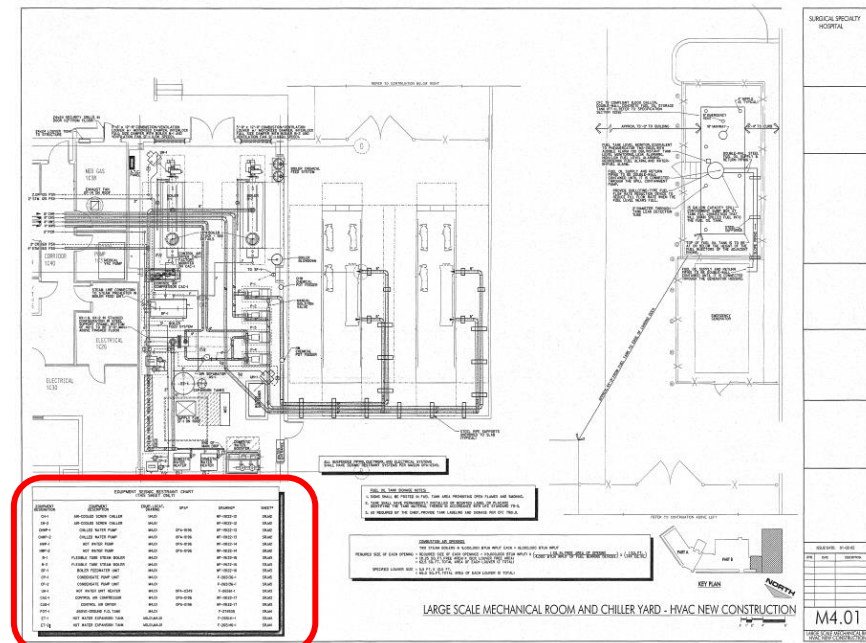

**EQUIPMENT SEISMIC RESTRAINT CHART
(THIS SHEET ONLY)**

EQUIPMENT DESIGNATION	EQUIPMENT DESCRIPTION	EQUIP. LOCAT. DRAWING	OPA*	DRAWING*	SHEET*
CH-1	AIR-COOLED SCREW CHILLER	M4.01		WF-19122-12	SR.M2
CH-2	AIR-COOLED SCREW CHILLER	M4.01		WF-19122-12	SR.M2
CHWP-1	CHILLED WATER PUMP	M4.01	OPA-0196	WF-19122-13	SR.M2
CHWP-2	CHILLED WATER PUMP	M4.01	OPA-0196	WF-19122-13	SR.M2
HWP-1	HOT WATER PUMP	M4.01	OPA-0196	WF-19122-14	SR.M2
HWP-2	HOT WATER PUMP	M4.01	OPA-0196	WF-19122-14	SR.M2
B-1	FLEXIBLE TUBE STEAM BOILER	M4.01		WF-19122-15	SR.M3
B-2	FLEXIBLE TUBE STEAM BOILER	M4.01		WF-19122-15	SR.M3
BF-1	BOILER FEEDWATER UNIT	M4.01		WF-19122-16	SR.M3
CP-1	CONDENSATE PUMP UNIT	M4.01		F-265136-1	SR.M5
CP-2	CONDENSATE PUMP UNIT	M4.01		F-265136-1	SR.M5
UH-1	HOT WATER UNIT HEATER	M4.01	OPA-0349	F-26561-1	SR.M3
CAC-1	CONTROL AIR COMPRESSOR	M4.01	OPA-0196	WF-19122-17	SR.M3
CAD-1	CONTROL AIR DRYER	M4.01	OPA-0196	WF-19122-17	SR.M3
FOT-1	ABOVE-GROUND F.O. TANK	M4.01		F-274535	SR.M4
ET-1	HOT WATER EXPANSION TANK	M0.01,M4.01		F-265141-1	SR.M4
ET-2	HOT WATER EXPANSION TANK	M0.01,M4.01		F-265146-1	SR.M4

Expansion tank ET-2 is anchored with:

- A. 8 – 3/8” dia. Red Head w/3-inch embedment
- B. 4 – 1/2” dia. Red head w/4-inch embedment ✓
- C. 4 – 5/8” dia. Red Head w/6-inch embedment
- D. 6 – 3/4” dia. Red Head w/4-inch embedment

Then go to the referenced sheet (SR.M4)

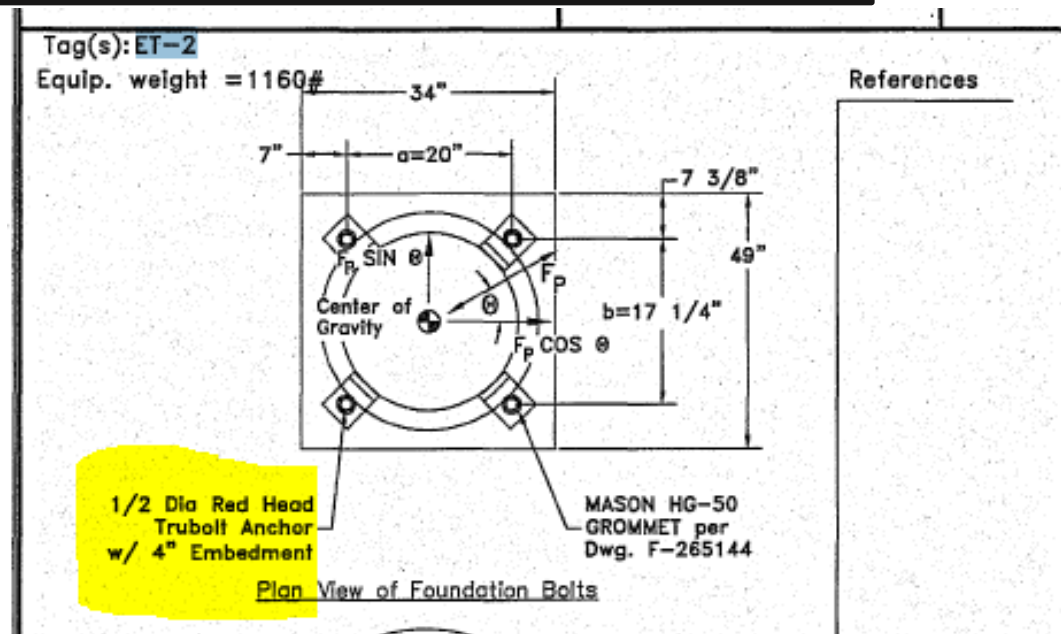
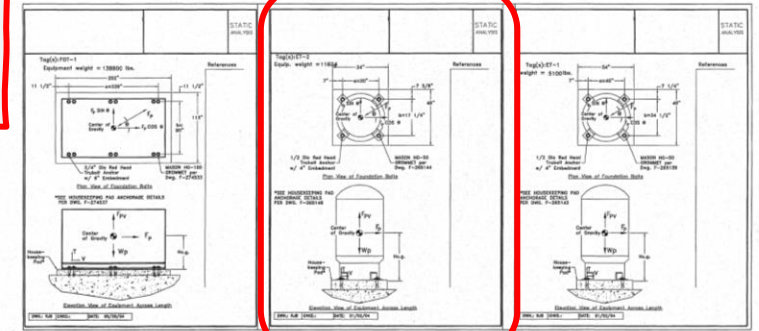

Example #2



How many bolts are required to attach the beam at the second floor along gridline M to the column at gridline 23?

2nd floor framing plan, look to grid line M and 23. Look also for detail 2/S4.1

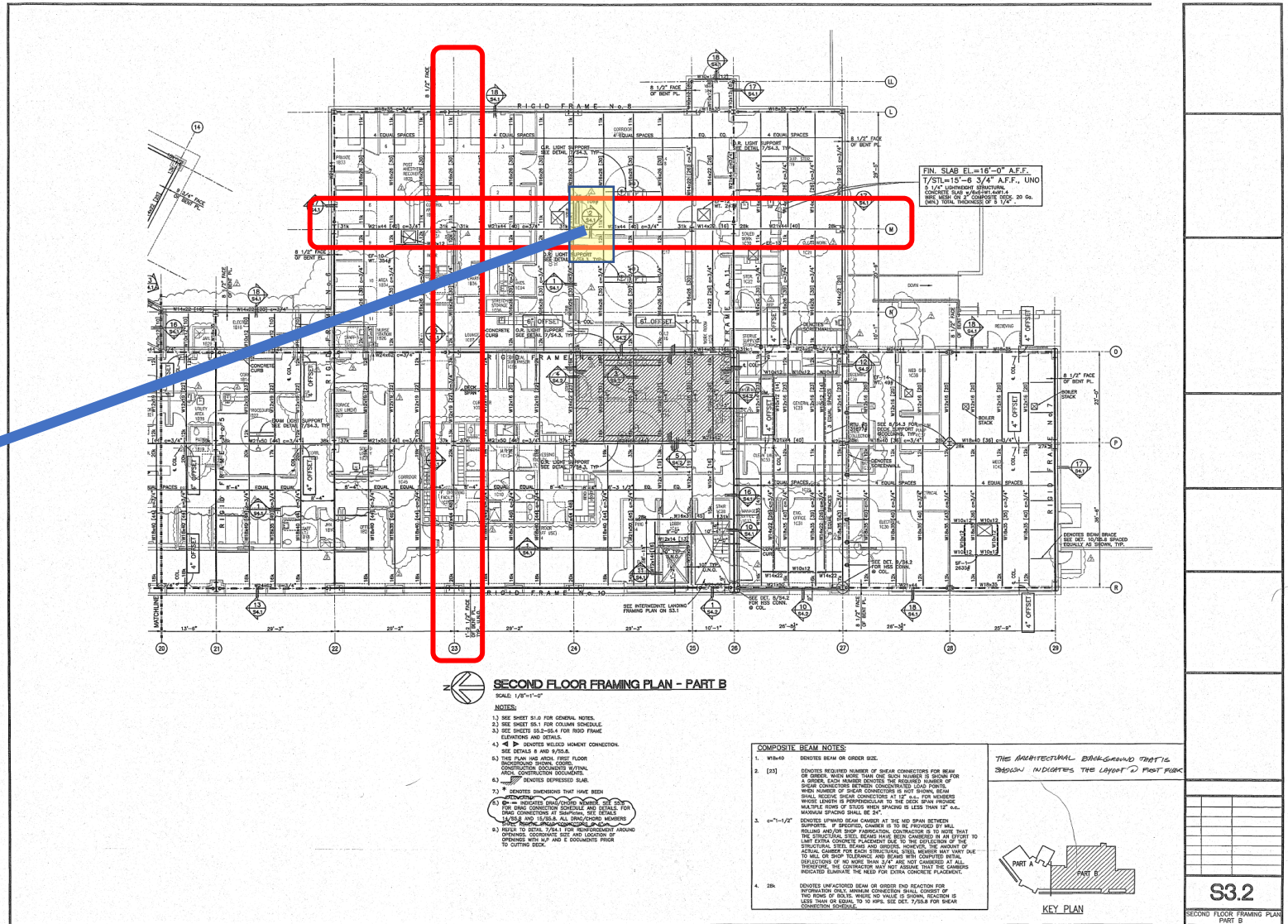
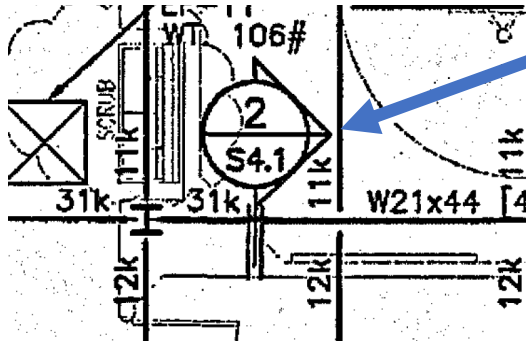

How many bolts are required to attach the beam at the second floor along gridline M to the column at gridline 23?

- A. 5
- B. 6 ✓
- C. 7
- D. 8

Detail 2/S4.1 refers to Beam schedule. The schedule is in Beam/column connection sheet, detail 7/S5.8

And remember the beam size from framing plan (W21)

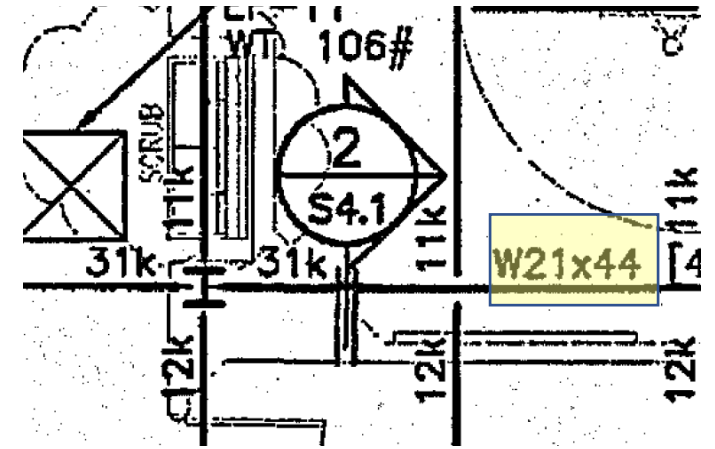

BEAM SHEAR CONNECTION SCHEDULE					
BEAM SIZE	SHEAR PLATE THICKNESS	B O L T S		WELD "A"	REMARKS
		NO.	DIA.		
W8	3/8"	2	3/4"	5/16"	
W10	3/8"	2	3/4"	5/16"	
W10x26	3/8"	2	1"	5/16"	
W12,W14	3/8"	3	3/4"	5/16"	
W16	3/8"	4	3/4"	5/16"	
W18	3/8"	5	3/4"	3/8"	
W21	1/2"	6	1"	3/8"	
W24,W27	1/2"	7	1"	3/8"	
W30	1/2"	8	1"	3/8"	
W33x	1/2"	9	1"	3/8"	
W36x	1/2"	10	1"	3/8"	

⑦ SHEAR CONNECTION SCHEDULE

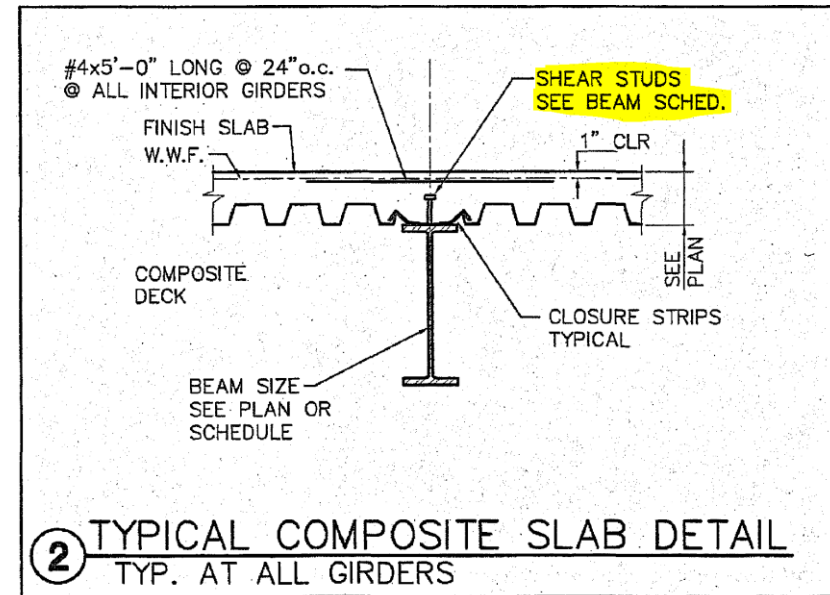

Example #3



Base plate size and thickness for column at the intersection of grid lines P and 27 is _____.

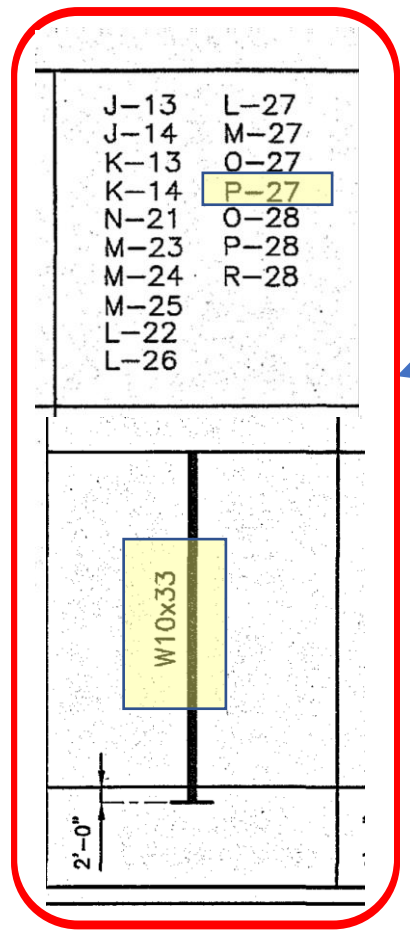

J-13	L-27
J-14	M-27
K-13	O-27
K-14	P-27
N-21	O-28
M-23	P-28
M-24	R-28
M-25	
L-22	
L-26	

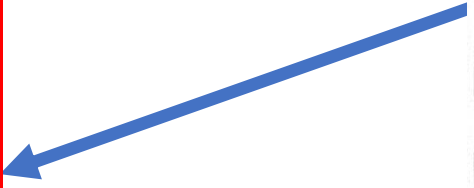

Look at the column schedule on S5.1, and find P-27.
After this, look for the column size

COLUMN SCHEDULE									
COL. NO.	SECTION	TYPE	SIZE	HEIGHT	MARK	FLOOR	MARK	FLOOR	MARK
S-13.8	R-27	W10x33	10	11.5		ROOF SLAB			
P-27		W10x33	10	11.5		SECOND FLOOR SLAB (LOW ROOF)			
		W10x49	10	11.5		SLAB ON GRADE			
		W10x60	10	11.5		BASE PLATE			
		W10x69	10	11.5					
		W10x87	10	11.5					
		W10x117	10	11.5					
		W10x135	10	11.5					
		W10x154	10	11.5					
		W10x176	10	11.5					
		W10x194	10	11.5					
		W10x211	10	11.5					
		W10x233	10	11.5					
		W10x260	10	11.5					
		W10x290	10	11.5					
		W10x330	10	11.5					
		W10x396	10	11.5					
		W10x454	10	11.5					
		W10x540	10	11.5					
		W10x644	10	11.5					
		W10x770	10	11.5					
		W10x914	10	11.5					
		W10x1075	10	11.5					
		W10x1254	10	11.5					
		W10x1453	10	11.5					
		W10x1674	10	11.5					
		W10x1917	10	11.5					
		W10x2183	10	11.5					
		W10x2472	10	11.5					
		W10x2785	10	11.5					
		W10x3123	10	11.5					
		W10x3496	10	11.5					
		W10x3906	10	11.5					
		W10x4354	10	11.5					
		W10x4842	10	11.5					
		W10x5361	10	11.5					
		W10x5911	10	11.5					
		W10x6493	10	11.5					
		W10x7107	10	11.5					
		W10x7763	10	11.5					
		W10x8461	10	11.5					
		W10x9191	10	11.5					
		W10x9953	10	11.5					
		W10x10747	10	11.5					
		W10x11573	10	11.5					
		W10x12431	10	11.5					
		W10x13321	10	11.5					
		W10x14243	10	11.5					
		W10x15197	10	11.5					
		W10x16183	10	11.5					
		W10x17191	10	11.5					
		W10x18221	10	11.5					
		W10x19273	10	11.5					
		W10x20347	10	11.5					
		W10x21443	10	11.5					
		W10x22561	10	11.5					
		W10x23691	10	11.5					
		W10x24833	10	11.5					
		W10x25987	10	11.5					
		W10x27153	10	11.5					
		W10x28331	10	11.5					
		W10x29521	10	11.5					
		W10x30723	10	11.5					
		W10x31937	10	11.5					
		W10x33163	10	11.5					
		W10x34401	10	11.5					
		W10x35651	10	11.5					
		W10x36913	10	11.5					
		W10x38187	10	11.5					
		W10x39473	10	11.5					
		W10x40771	10	11.5					
		W10x42081	10	11.5					
		W10x43393	10	11.5					
		W10x44717	10	11.5					
		W10x46053	10	11.5					
		W10x47401	10	11.5					
		W10x48761	10	11.5					
		W10x50133	10	11.5					
		W10x51517	10	11.5					
		W10x52913	10	11.5					
		W10x54321	10	11.5					
		W10x55741	10	11.5					
		W10x57173	10	11.5					
		W10x58617	10	11.5					
		W10x60073	10	11.5					
		W10x61541	10	11.5					
		W10x63021	10	11.5					
		W10x64513	10	11.5					
		W10x66017	10	11.5					
		W10x67533	10	11.5					
		W10x69061	10	11.5					
		W10x70601	10	11.5					
		W10x72153	10	11.5					
		W10x73717	10	11.5					
		W10x75293	10	11.5					
		W10x76881	10	11.5					
		W10x78481	10	11.5					
		W10x80093	10	11.5					
		W10x81717	10	11.5					
		W10x83353	10	11.5					
		W10x85001	10	11.5					
		W10x86661	10	11.5					
		W10x88333	10	11.5					
		W10x90017	10	11.5					
		W10x91713	10	11.5					
		W10x93421	10	11.5					
		W10x95141	10	11.5					
		W10x96873	10	11.5					
		W10x98617	10	11.5					
		W10x100373	10	11.5					
		W10x102137	10	11.5					
		W10x103901	10	11.5					
		W10x105673	10	11.5					
		W10x107451	10	11.5					
		W10x109233	10	11.5					
		W10x111017	10	11.5					
		W10x112801	10	11.5					
		W10x114583	10	11.5					
		W10x116367	10	11.5					
		W10x118151	10	11.5					
		W10x119933	10	11.5					
		W10x121717	10	11.5					
		W10x123501	10	11.5					
		W10x125283	10	11.5					
		W10x127067	10	11.5					
		W10x128851	10	11.5					
		W10x130633	10	11.5					
		W10x132417	10	11.5					
		W10x134201	10	11.5					
		W10x135983	10	11.5					
		W10x137767	10	11.5					
		W10x139551	10	11.5					
		W10x141333	10	11.5					
		W10x143117	10	11.5					
		W10x144901	10	11.5					
		W10x146683	10	11.5					
		W10x148467	10	11.5					
		W10x150251	10	11.5					
		W10x152033	10	11.5					
		W10x153817	10	11.5					
		W10x155601	10	11.5					
		W10x157383	10	11.5					
		W10x159167	10	11.5					
		W10x160951	10	11.5					
		W10x162733	10	11.5					
		W10x164517	10	11.5					
		W10x166301	10	11.5					
		W10x168083	10	11.5					
		W10x169867	10	11.5					
		W10x171651	10	11.5					
		W10x173433	10	11.5					
		W10x175217	10	11.5					
		W10x177001	10	11.5					
		W10x178783	10	11.5					
		W10x180567	10	11.5					
		W10x182351	10	11.5					
		W10x184133	10	11.5					
		W10x185917	10	11.5					
		W10x187701	10	11.5					
		W10x189483	10	11.5					
		W10x191267	10	11.5					
		W10x193051	10	11.5					
		W10x194833	10	11.5					
		W10x196617	10	11.5					
		W10x198401	10	11.5					
		W10x200183	10	11.5					
		W10x201967	10	11.5					
		W10x203751	10	11.5					
		W10x205533	10	11.5					
		W10x207317	10	11.5					
		W10x209101	10	11.5					
		W10x210883	10	11.5					
		W10x212667	10	11.5					
		W10x214451	10	11.5					
		W10x216233	10	11.5					
		W10x218017	10	11.5					
		W10x219801	10	11.5					
		W10x221583	10	11.5					
		W10x223367	10	11.5					
		W10x225151	10	11.5					
		W10x226933	10	11.5					
		W10x228717	10	11.5					
		W10x230501	10	11.5					
		W10x232283	10	11.5					
		W10x234067	10	11.5					
		W10x235851	10	11.5					
		W10x237633	10	11.5					
		W10x239417	10	11.5					
		W10x241201	10	11.5					
		W10							

Base plate size and thickness for column at the intersection of grid lines P and 27 is _____.

- A. 18" x 18" x 1" ✓
- B. 18" x 18" x 1¼"
- C. 20" x 20" x 1"
- D. 20" x 20" x 1½"

In the same sheet, look for the Base Plate Schedule to find the answer for W10x23



COL. SIZE	PLATE SIZE				ANCHOR BOLTS			
	THK.	A	B	C	D	NO.	DIA.	EMBED.
W10x33	1"	18"	18"	7"	7"	4	3/4"	9"
W10x39	1"	18"	18"	7"	7"	4	3/4"	9"
W10x49	1-1/4"	18"	18"	7"	7"	4	3/4"	9"
W10x68	1-1/4"	18"	18"	7"	7"	4	3/4"	9"
HSS4x4	3/4"	12"	12"	4"	4"	4	3/4"	9"

NOTE:
GRAVITY COLUMN ANCHOR BOLTS TO BE GRADE A307

1 BASE PLATE SCHEDULE

Example #4



The kitchen equipment is anchored to what type of concrete?

First, look the Food Service Equipment Schedule, and see references for seismic detail. You will see references from SRA6-10.

SCHEDULE OF EQUIPMENT				
ITEM	DESCRIPTION	SEISMIC DETAILS (DETAIL #/SHEET)	OPA APPROVAL	REMARKS
1	TRASH RECEPTACLE	--	--	BY OWNER
2	HAND SINK	--	--	BY PLUMBING CONTRACTOR
3	SINK W/ DISPOSABLE	F-278155/SRA6, F-278157/SRA6	--	W/ PRE-RINSE
4	DISPOSER W/ CONTROL	--	--	--
5	BACK SHELF	F-278163/SRA10	--	--
6	DISH MACHINE	F-278156/SRA6, F-278158/SRA6	--	--
7	CONDENSATE HOOD	F-27778/SRA6, F-27779/SRA6, F-27780/SRA6, F-27781/SRA6	R-0349	--
8	BACK SHELF	F-278163/SRA10	--	--
9	SPARE NUMBER	--	--	--
10	SPARE NUMBER	--	--	--
11	BOOSTER HEATER	F-278155/SRA6, 278159/SRA6	--	--
12	CLEAN DIGITABLE	F-278155/SRA6, F-278160/SRA6	--	--
13	MOBILE CUP/GLASS RACK DOLLY	--	--	--
14	S/S CORNER GUARD	--	--	--
15	SMART WALL ASSEMBLY	F-277780/SRA6	--	--
16	3-COMPARTMENT SINK	F-278164/SRA6, F-278165/SRA6, F-278167/SRA6	--	--
17	SMART WALL ASSEMBLY	F-277780/SRA6	--	--
18	FLOOR TROUGH W/ GRATE	--	--	--
19	SPARE NUMBER	--	--	--
20	SPARE NUMBER	--	--	--
21	FIRE SUPPRESSION SYSTEM	F-277293/SRA7	--	--
22	COFFEE BREWER	--	--	BY VENDOR
23	ICED TEA BREWER	--	--	BY VENDOR
24	TOASTER	--	--	--
25	BEVERAGE COUNTER	F-278155/SRA6, F-278161/SRA6	--	--
26	SMART WALL ASSEMBLY	F-277780/SRA6	--	--
27	MOBILE 3-WELL HOT FOOD TABLE	--	--	--
28	MOBILE TRAY TRANSPORT CART	--	--	--
29	SPARE NUMBER	--	--	--
30	SPARE NUMBER	--	--	--
31	MOBILE HOT BOX / PROOFER	--	--	--
32	S/S WALL FLASHING	F-277284/SRA6, F-277285/SRA6, F-277286/SRA6, F-277287/SRA6	R-0349	--
33	EXHAUST VENTILATOR	F-277288/SRA7	--	--
34	STEAMER	F-277288/SRA7	--	--
35	COMBINATION RANGE/GRIDDLE	F-277289/SRA7	--	--
36	FRYER/FLEISHER UNIT	F-277289/SRA7	--	--
37	REACH-IN FREEZER	F-277308/SRA7	--	--
38	REACH-IN REFRIGERATOR	F-277308/SRA7	--	--
39	SPARE NUMBER	--	--	--
40	SPARE NUMBER	--	--	--
41	REACH-IN FREEZER	F-277308/SRA7	--	--
42	SMART WALL ASSEMBLY	F-277780/SRA6	--	--
43	OFFICE FURNITURE	--	--	BY OWNER
44	STORAGE SHELVING	F-277783/SRA6	--	--
45	DUNNAGE SHELF	--	--	--
46	TABLE MOUNTED CAN OPENER	--	--	--
47	TRASH RECEPTACLE	--	--	BY OWNER
48	SMART WALL ASSEMBLY	F-277780/SRA6	--	--
49	SPARE NUMBER	--	--	--
50	SPARE NUMBER	--	--	--
51	PREPARATION TABLE W/ SINKS	F-278174/SRA6, F-178175/SRA6	--	--
52	DISPOSER W/ CONTROL	--	--	--
53	FOOD PROCESSOR	--	--	--
54	MOBILE INGREDIENT BINS	--	--	--
55	SLICER	--	--	--
56	ICE MAKER W/ FILTER	F-277301/SRA7	--	--
57	ICE BIN	F-277301/SRA7	--	--
58	MOP SINK	--	--	BY PLUMBING CONTRACTOR
59	WALL SHELF	F-278179/SRA6	--	--
60	MOP RACK	--	--	BY PLUMBING CONTRACTOR
61	MOBILE POT/PAN RACK	--	--	--
62	HOSE BIBB	--	--	BY PLUMBING CONTRACTOR
63	PREP TABLE	F-278170/SRA6, F-278172/SRA6	--	--
64	SMART WALL ASSEMBLY	F-277780/SRA6	--	--

GENERAL NOTES

SEISMIC DATA SHALL BE OBTAINED FROM THE SEISMIC DESIGN REPORT FOR THIS PROJECT AND SHALL BE PROVIDED TO THE ARCHITECT AND ENGINEER FOR REVIEW AND APPROVAL. THE SEISMIC DESIGN REPORT SHALL BE PROVIDED TO THE ARCHITECT AND ENGINEER FOR REVIEW AND APPROVAL. THE SEISMIC DESIGN REPORT SHALL BE PROVIDED TO THE ARCHITECT AND ENGINEER FOR REVIEW AND APPROVAL.

SCHEDULE OF EQUIPMENT

ITEM	DESCRIPTION	SEISMIC DETAILS (DETAIL #/SHEET)	OPA APPROVAL	REMARKS
1	TRASH RECEPTACLE	--	--	BY OWNER
2	HAND SINK	--	--	BY PLUMBING CONTRACTOR
3	SINK W/ DISPOSABLE	F-278155/SRA6, F-278157/SRA6	--	W/ PRE-RINSE
4	DISPOSER W/ CONTROL	--	--	--
5	BACK SHELF	F-278163/SRA10	--	--
6	DISH MACHINE	F-278156/SRA6, F-278158/SRA6	--	--
7	CONDENSATE HOOD	F-27778/SRA6, F-27779/SRA6, F-27780/SRA6, F-27781/SRA6	R-0349	--
8	BACK SHELF	F-278163/SRA10	--	--
9	SPARE NUMBER	--	--	--
10	SPARE NUMBER	--	--	--
11	BOOSTER HEATER	F-278155/SRA6, 278159/SRA6	--	--
12	CLEAN DIGITABLE	F-278155/SRA6, F-278160/SRA6	--	--
13	MOBILE CUP/GLASS RACK DOLLY	--	--	--
14	S/S CORNER GUARD	--	--	--
15	SMART WALL ASSEMBLY	F-277780/SRA6	--	--
16	3-COMPARTMENT SINK	F-278164/SRA6, F-278165/SRA6, F-278167/SRA6	--	--
17	SMART WALL ASSEMBLY	F-277780/SRA6	--	--
18	FLOOR TROUGH W/ GRATE	--	--	--
19	SPARE NUMBER	--	--	--
20	SPARE NUMBER	--	--	--
21	FIRE SUPPRESSION SYSTEM	F-277293/SRA7	--	--
22	COFFEE BREWER	--	--	BY VENDOR
23	ICED TEA BREWER	--	--	BY VENDOR
24	TOASTER	--	--	--
25	BEVERAGE COUNTER	F-278155/SRA6, F-278161/SRA6	--	--
26	SMART WALL ASSEMBLY	F-277780/SRA6	--	--
27	MOBILE 3-WELL HOT FOOD TABLE	--	--	--
28	MOBILE TRAY TRANSPORT CART	--	--	--
29	SPARE NUMBER	--	--	--
30	SPARE NUMBER	--	--	--
31	MOBILE HOT BOX / PROOFER	--	--	--
32	S/S WALL FLASHING	F-277284/SRA6, F-277285/SRA6, F-277286/SRA6, F-277287/SRA6	R-0349	--
33	EXHAUST VENTILATOR	F-277288/SRA7	--	--
34	STEAMER	F-277288/SRA7	--	--
35	COMBINATION RANGE/GRIDDLE	F-277289/SRA7	--	--
36	FRYER/FLEISHER UNIT	F-277289/SRA7	--	--
37	REACH-IN FREEZER	F-277308/SRA7	--	--
38	REACH-IN REFRIGERATOR	F-277308/SRA7	--	--
39	SPARE NUMBER	--	--	--
40	SPARE NUMBER	--	--	--
41	REACH-IN FREEZER	F-277308/SRA7	--	--
42	SMART WALL ASSEMBLY	F-277780/SRA6	--	--
43	OFFICE FURNITURE	--	--	BY OWNER
44	STORAGE SHELVING	F-277783/SRA6	--	--
45	DUNNAGE SHELF	--	--	--
46	TABLE MOUNTED CAN OPENER	--	--	--
47	TRASH RECEPTACLE	--	--	BY OWNER
48	SMART WALL ASSEMBLY	F-277780/SRA6	--	--
49	SPARE NUMBER	--	--	--
50	SPARE NUMBER	--	--	--
51	PREPARATION TABLE W/ SINKS	F-278174/SRA6, F-178175/SRA6	--	--
52	DISPOSER W/ CONTROL	--	--	--
53	FOOD PROCESSOR	--	--	--
54	MOBILE INGREDIENT BINS	--	--	--
55	SLICER	--	--	--
56	ICE MAKER W/ FILTER	F-277301/SRA7	--	--
57	ICE BIN	F-277301/SRA7	--	--
58	MOP SINK	--	--	BY PLUMBING CONTRACTOR
59	WALL SHELF	F-278179/SRA6	--	--
60	MOP RACK	--	--	BY PLUMBING CONTRACTOR
61	MOBILE POT/PAN RACK	--	--	--
62	HOSE BIBB	--	--	BY PLUMBING CONTRACTOR
63	PREP TABLE	F-278170/SRA6, F-278172/SRA6	--	--
64	SMART WALL ASSEMBLY	F-277780/SRA6	--	--

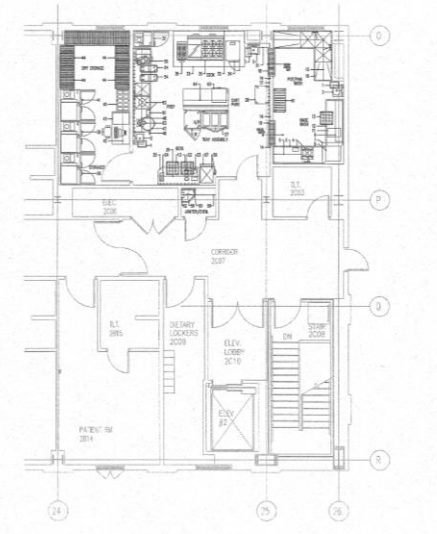

NOTE: THIS DRAWING INDICATES THE GENERAL EXTENT OF WORK AND IS NOT INTENDED TO INDICATE OR DESCRIBE ALL WORK REQUIRED FOR THE FULL PERFORMANCE AND COMPLETION OF THE REQUIREMENTS OF THE CONTRACT DOCUMENTS.

SCALE: 1/4" = 1'-0"

KITCHEN EQUIPMENT LAYOUT

The kitchen equipment is anchored to what type of concrete?

Let's look at them from SRA6-10 and see the one anchored.

The equipment anchored are on SRA7-9

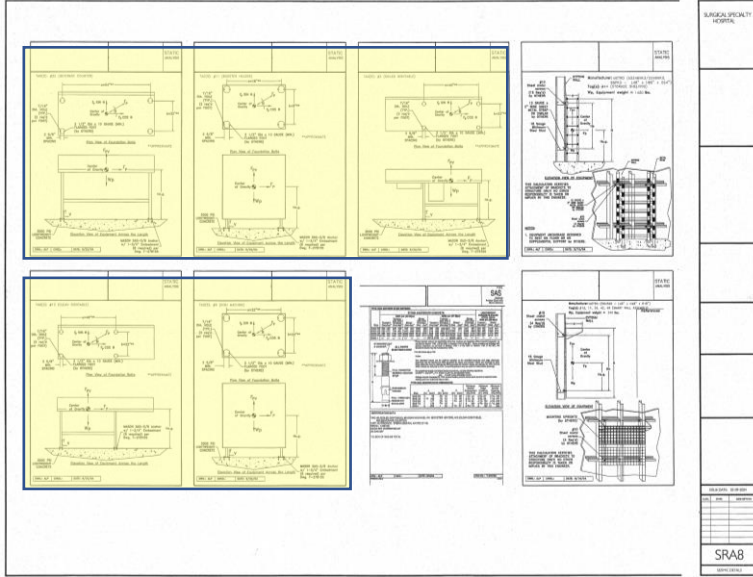
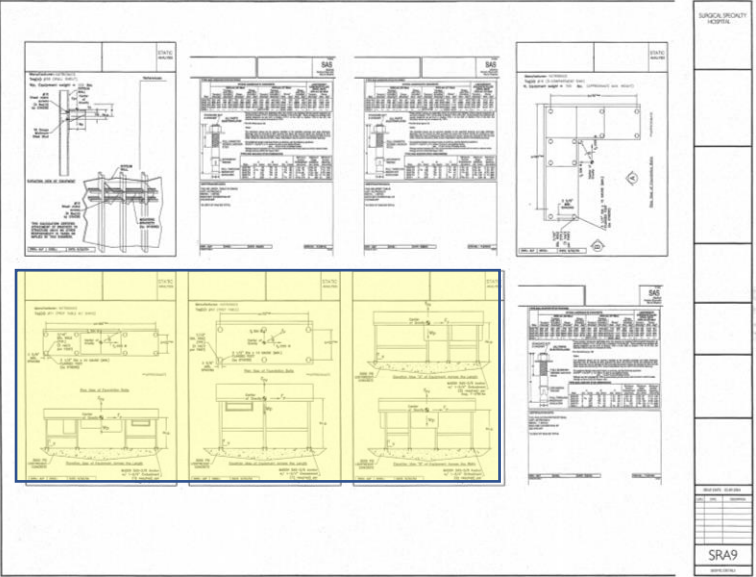
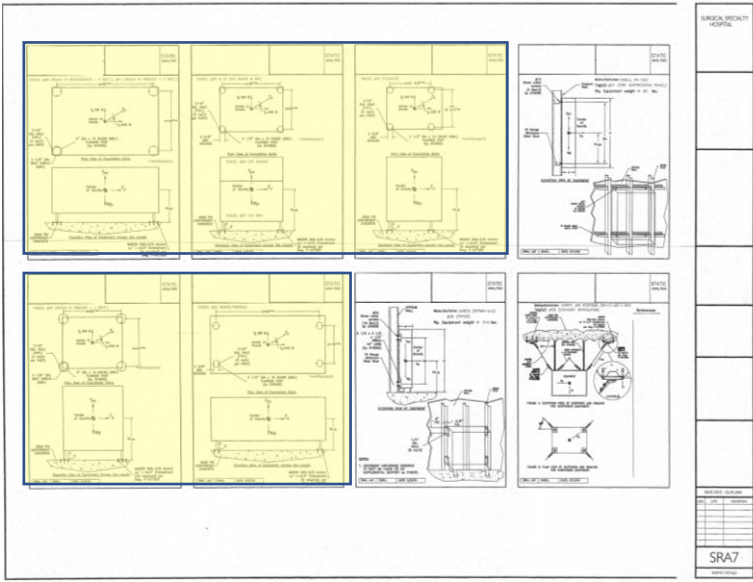

The kitchen equipment is anchored to what type of concrete?

- A. 3,000 psi
- B. 3,000 psi, lightweight ✓
- C. 4,000 psi
- D. 4,000 psi, lightweight

Let's look at them from SRA6-10 and see the one anchored.

The equipment anchored are on SRA7-9

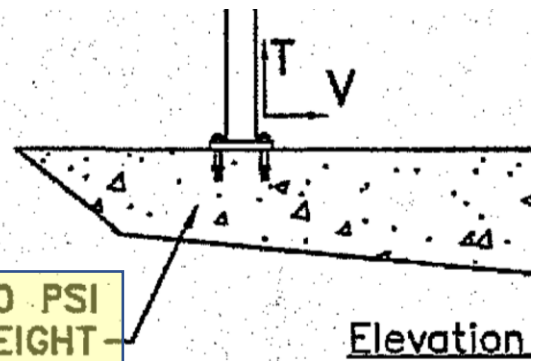

Example #5



Hot water recirculation pumps HWRP-1 and HWRP-2 are:

First of all, look into the Plumbing sheet for the pump seismic restraint chart

EQUIPMENT SEISMIC RESTRAINT CHART (THIS SHEET ONLY)					
EQUIPMENT DESIGNATION	EQUIPMENT DESCRIPTION	EQUIP. LOCAT. DRAWING	OPA#	DRAWING#	SHEET#
WH-1	WATER HEATER	P3.01		WF-19122-18	SR,PI
WH-2	WATER HEATER	P3.01		WF-19122-18	SR,PI
HWRP-1	HOT WATER RECIR PUMP	P3.01	OPA-0349	WF-19122-28	SR,PI
HWRP-2	HOT WATER RECIR PUMP	P3.01	OPA-0349	WF-19122-28	SR,PI
BP-1	BOOSTER PUMP	P3.01		WF-19122-19	SR,PI
WSF-1	WATER SOFTNER	P3.01		WF-19122-20	SR,PI
MVP-1	MEDICAL VACUUM PUMP	P2.02		F-265170-1	SR,PI
AIR	AIR MANIFOLD	P2.02		F-265170-1	SR,PI
NITROUS	NITROUS MANIFOLD	P2.02		F-265170-1	SR,PI
NITROGEN	NITROGEN MANIFOLD	P2.02		F-265170-1	SR,PI
OXYGEN	OXYGEN MANIFOLD	P2.02		F-265170-1	SR,PI

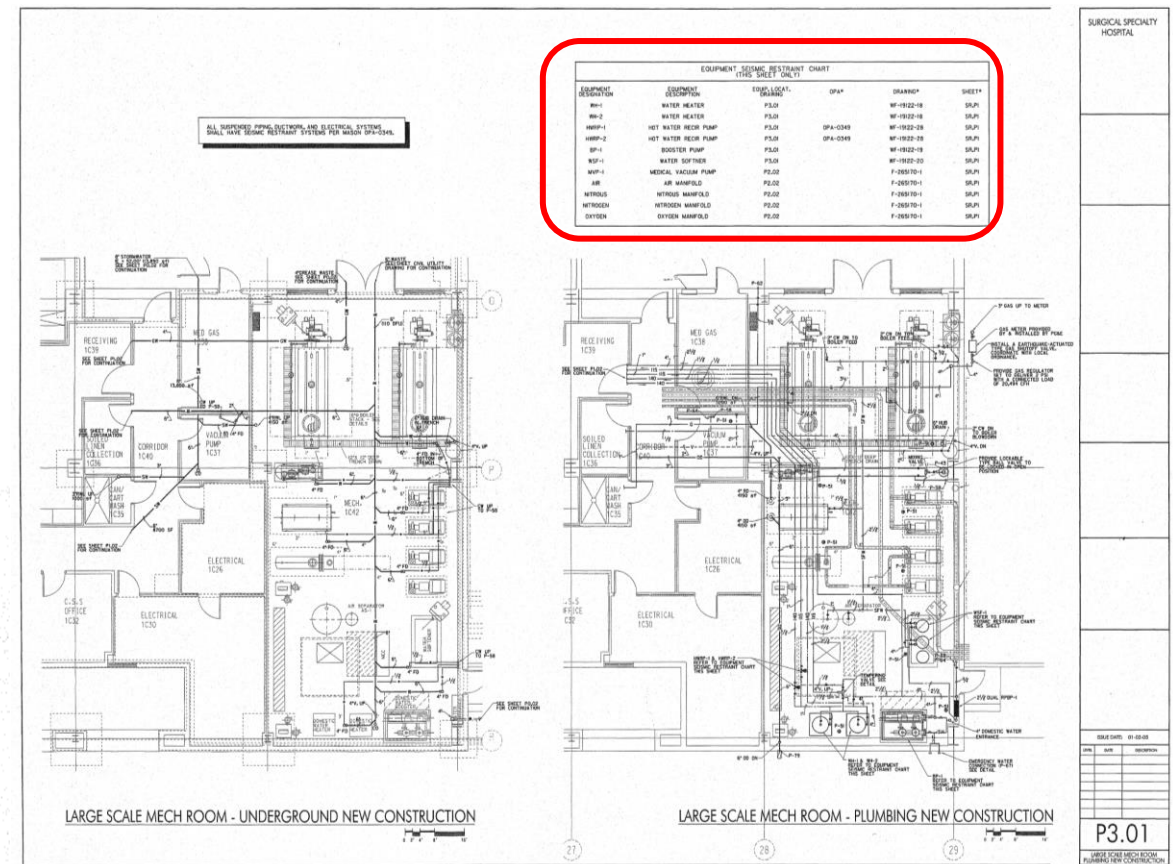

Hot water recirculation pumps HWRP-1 and HWRP-2 are:

- A. Mounted on housekeeping slabs
- B. Mounted on pedestals
- C. **Suspended from the deck** ✓
- D. Wall mounted

Go to SR.P1, and look for WF-19122-28

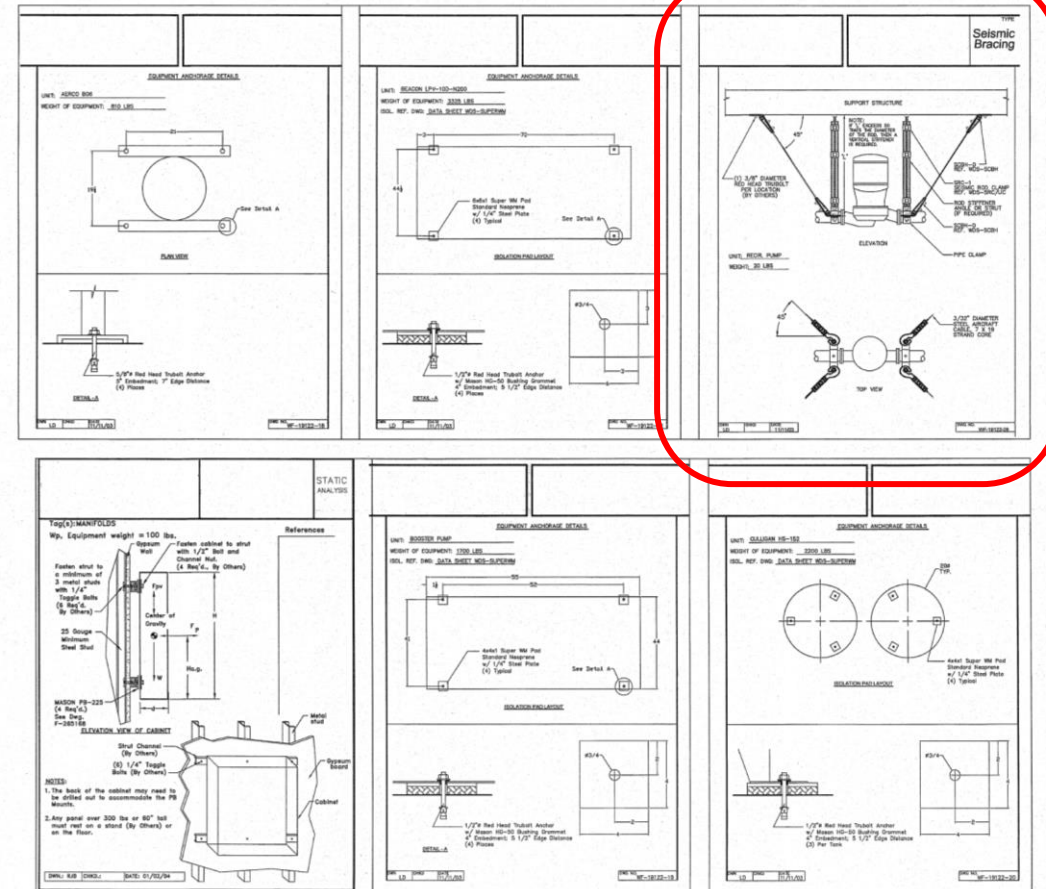
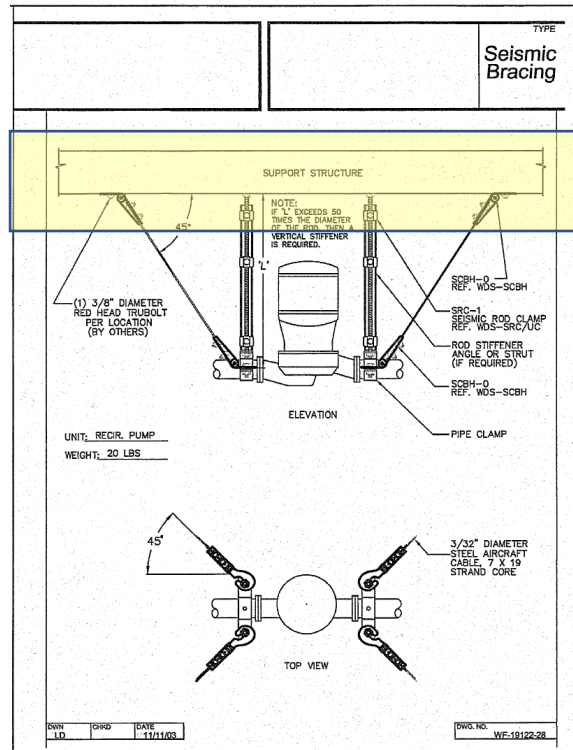

Homework

Homework #1

What reinforcing steel is required for the footing at the intersection of grid lines O and 23?

- A. 4 - #4 Bottom
- B. 6 - #6 Bottom
- C. 10 - #6 Bottom
- D. 9 - #6 Top & Bottom
- E. 13 - #7 Top & Bottom

Homework #2

The typical header for a 10-foot clear opening in the exterior wall would be:

- A. 2- 6"x18ga. studs with 3- 6"x14ga. Tracks
- B. 1- 6"x18ga. stud with 2- 6"x18ga. Tracks
- C. 3- 6"x14ga. studs with 3- 6"x 14ga. Tracks
- D. 2- 6"x18ga. studs with 2- 6"x18ga. tracks



Resolution

Homework #1

What reinforcing steel is required for the footing at the intersection of grid lines O and 23?

- A. 4 - #4 Bottom
- B. 6 - #6 Bottom
- C. 10 - #6 Bottom
- D. 9 - #6 Top & Bottom
- E. 13 - #7 Top & Bottom

Homework #2

The typical header for a 10-foot clear opening in the exterior wall would be:

- A. 2- 6"x18ga. studs with 3- 6"x14ga. Tracks
- B. 1- 6"x18ga. stud with 2- 6"x18ga. Tracks
- C. 3- 6"x14ga. studs with 3- 6"x 14ga. Tracks
- D. 2- 6"x18ga. studs with 2- 6"x18ga. tracks



What reinforcing steel is required for the footing at the intersection of grid lines O and 23?

At the foundation plan, look column O-23 and read the footing mark (F7).

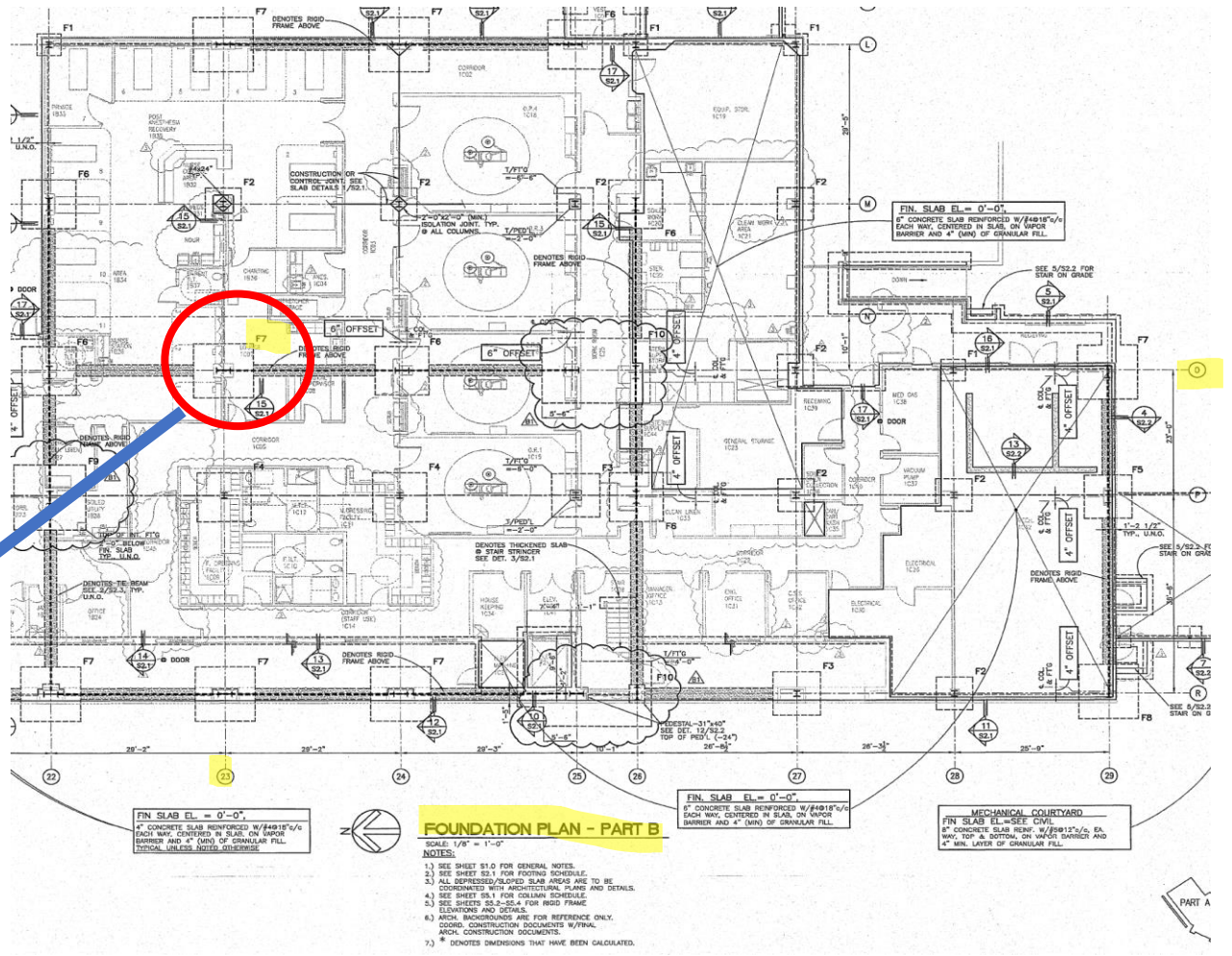
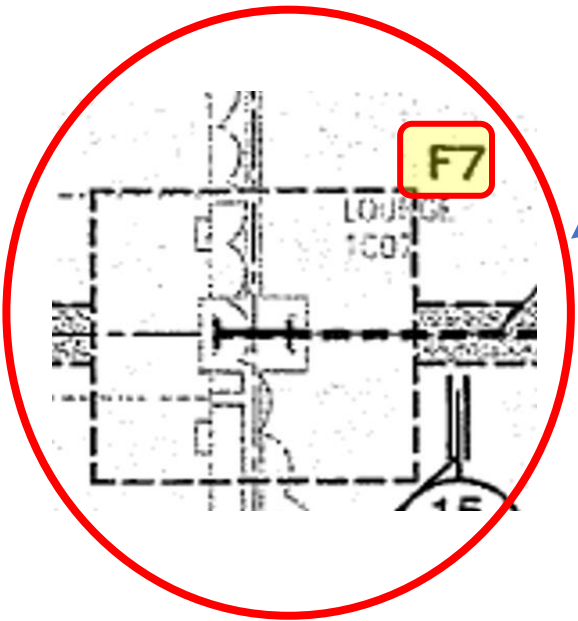

What reinforcing steel is required for the footing at the intersection of grid lines O and 23?

- A. 4 - #4 Bottom
- B. 6 - #6 Bottom
- C. 10 - #6 Bottom
- D. 9 - #6 Top & Bottom
- E. 13 - #7 Top & Bottom ✓

Then go to Foundation details sheet and look for the footing schedule

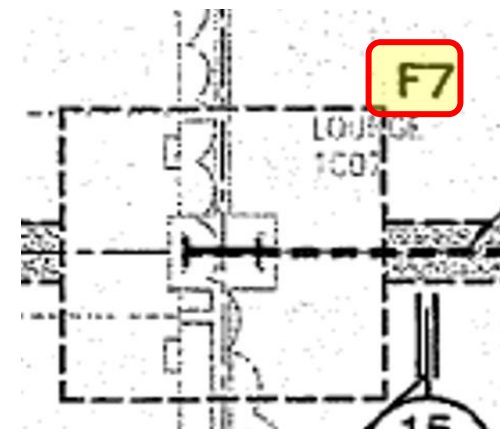

FOOTING SCHEDULE						
FOOTINGS			PEDESTALS			NOTES
MARK	SIZE	REINF. EA. WAY	SIZE	REINF.	TIES	
F1	4'-0" x 4'-0" x 1'-0"	4-#4 BOT				
F2	6'-0" x 6'-0" x 1'-6"	6-#6 BOT	22" x 22"	12-#5	#3@12"	G13.9, M25
F3	8'-0" x 8'-0" x 2'-0"	9-#6 BOT	22" x 22"	12-#5	#3@12"	G15, P25
F4	9'-0" x 9'-0" x 2'-0"	10-#6 BOT				
F5	8'-0" x 8'-0" x 4'-0"	9-#6 TOP&BOT				
F6	9'-0" x 9'-0" x 6'-0"	10-#7 TOP&BOT				
F7	10'-0" x 10'-0" x 7'-0"	13-#7 TOP&BOT				
F8	10'-0" x 10'-0" x 8'-0"	13-#6 TOP&BOT				
F9	12'-0" x 12'-0" x 8'-0"	13-#8 TOP&BOT				
F10	18'-0" x 12'-0" x 6'-0"	#8@12" TOP&BOT		SEE 12/S2.2		R25, R26

NOTE: SEE DET. / S2.3 FOR TOP REINF. PLACEMENT IN RIGID FRAME FOOTINGS.

PED'L TIE PATTERN

④ FOOTING/PEDESTAL SCHEDULE

The typical header for a 10-foot clear opening in the exterior wall would be:

- A. 2- 6"x18ga. studs with 3- 6"x14ga. Tracks ✓
- B. 1- 6"x18ga. stud with 2- 6"x18ga. Tracks
- C. 3- 6"x14ga. studs with 3- 6"x 14ga. Tracks
- D. 2- 6"x18ga. studs with 2- 6"x18ga. tracks

Go to S4.4 where you can find the Header Schedule

HEADER SCHEDULE			
ROUGH OPENING	MEMBERS	BUILT-UP SECTION	NOTES
0'-0" TO 6'-4"	2-6", 18 Ga STUDS W/2-6", 18 Ga TRACKS		
6'-5" TO 8'-4"	2-6", 18 Ga STUDS W/2-6", 18 Ga TRACKS		
8'-5" TO 13'-0"	2-6", 18 Ga STUDS W/3-6", 14 Ga TRACKS		

NOTE:

- 1.) ALL MEMBERS TO HAVE 33 KSI YIELD STRENGTH.
- 2.) TRACK SECTIONS TO HAVE 1 1/4" LEG MIN.
- 3.) STUD SECTIONS HAVE 1 5/8" FLANGES, TYP. U.N.O.
- 4.) FASTEN EACH TRACK W/2-#1 SCREWS @ 16"/c FOR BUILT-UP SECTION.

2 HEADER SCHEDULE

HEADER SCHEDULE

ROUGH OPENING	MEMBERS	BUILT-UP SECTION	NOTES
0'-0" TO 6'-4"	2-6", 18 Ga STUDS W/2-6", 18 Ga TRACKS		
6'-5" TO 8'-4"	2-6", 18 Ga STUDS W/2-6", 18 Ga TRACKS		
8'-5" TO 13'-0"	2-6", 18 Ga STUDS W/3-6", 14 Ga TRACKS		

SILL SCHEDULE

ROUGH OPENING	MEMBERS	BUILT-UP SECTION	NOTES
0'-0" TO 6'-4"	1-6", 18 Ga TRACK		
6'-5" TO 8'-4"	1-6", 18 Ga TRACK		
8'-5" TO 13'-0"	1-6", 18 Ga TRACK W/2-6", 18 Ga TRACKS		

JAMB SCHEDULE

ROUGH OPENING	MEMBERS	BUILT-UP SECTION	NOTES
0'-0" TO 6'-4"	2-6", 18 Ga STUDS		
6'-5" TO 8'-4"	2-6", 18 Ga STUDS W/2-6", 18 Ga TRACKS		
8'-5" TO 13'-0"	2-6", 18 Ga STUDS W/3-6", 14 Ga TRACKS		

1 TYPICAL EXTERIOR WALL ELEVATION

2 DETAIL—FIRST FLOOR

3 DETAIL—SECOND FLOOR

4 DETAIL—ROOF

5 DETAIL—SILL TO JAMB

6 DETAIL—JAMB @ FIRST FLOOR

7 DETAIL—JAMB @ SECOND FLOOR

8 DETAIL—JAMB @ ROOF

9 DETAIL—FIRST FLOOR

10 DETAIL—SECOND FLOOR

11 DETAIL—ROOF

12 DETAIL—JAMB @ ROOF

S4.4

Mechanical & Plumbing



Example #1



What is the inlet pressure to the single stage pressure reducing station?

What do you have to look for?
See if there is Single Stage Pressure Reducing Station Detail..... And there is

The image displays a set of technical drawings for a steam system, organized into a grid of sheets. The central focus is sheet 6, titled 'SINGLE STAGE PRESSURE REDUCING STATION', which is highlighted with a red border. This sheet includes a detailed piping diagram and a 'PRESSURE REDUCING VALVE SCHEDULE' table. The table lists various valve types and their specifications:

NO.	TYPE	SIZE	ORIF.	VALVE	SERVICE
1	1	1	1	1	1
2	2	2	2	2	2
3	3	3	3	3	3
4	4	4	4	4	4
5	5	5	5	5	5
6	6	6	6	6	6
7	7	7	7	7	7
8	8	8	8	8	8
9	9	9	9	9	9
10	10	10	10	10	10
11	11	11	11	11	11
12	12	12	12	12	12
13	13	13	13	13	13
14	14	14	14	14	14
15	15	15	15	15	15
16	16	16	16	16	16
17	17	17	17	17	17
18	18	18	18	18	18
19	19	19	19	19	19
20	20	20	20	20	20

Other sheets in the grid include: 1. 'STEAM PIPING AT CONVERTOR', 2. 'STEAM PIPING AT BOILER FEED UNIT - SINGLE COMPARTMENT W/ STEAM PREHEAT', 3. 'STEAM PIPING AT HUMIDIFIER', 4. 'STEAM BOILER', 5. 'STEAM PIPING AT INSTANTANEOUS WATER HEATER', 6. 'STEAM PIPING AT STERILIZER', 7. 'CONDENSATE COOLER', 8. 'DUCT MOUNTED HUMIDIFIER', 9. 'STEAM PIPING AT UNIT HEATER', and 10. 'BLOWDOWN SEPARATOR'. Each sheet contains detailed piping diagrams, notes, and specifications for various components of the steam system.

SURGICAL SPECIALTY HOSPITAL

DATE: 01-05-05

NO. SHEET DESCRIPTION

M6.01

HANC DETAILS

What is the inlet pressure to the single stage pressure reducing station?

- A. 25 psi
- B. 40 psi
- C. 45 psi
- D. 60 psi



PRESSURE REDUCING VALVE SCHEDULE		
VALVE SIZE	P.S.I.	LEBS./H
1	60	700
1	60	900

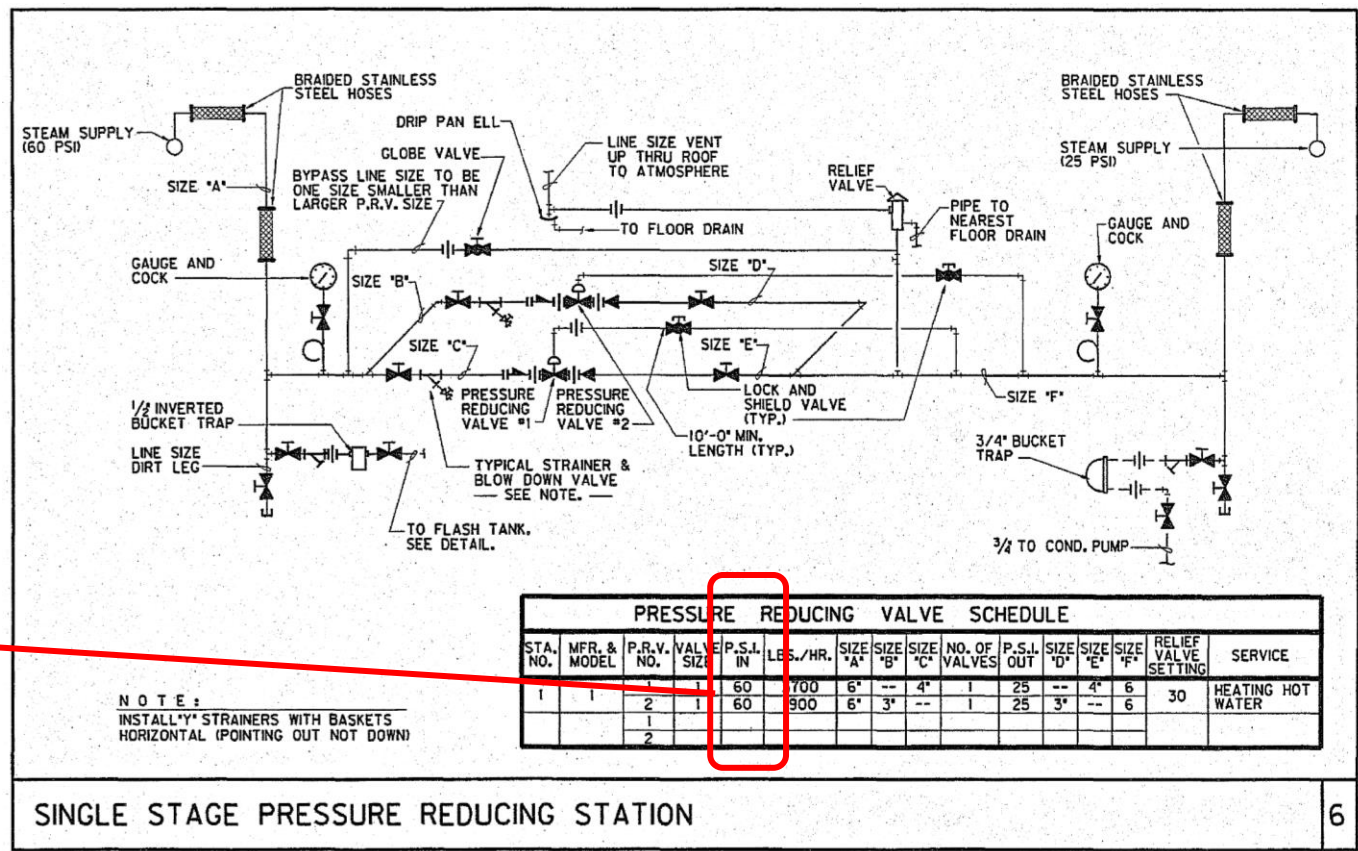

SINGLE STAGE PRESSURE REDUCING STATION

Example #2



The source valve for the nitrogen system is located in room _____.

First you need to know the symbol used for Nitrogen line

Table with 2 columns: SYMBOL and DESCRIPTION. Lists symbols for compressed air, vacuum, oxygen, nitrogen (highlighted), nitrous oxide, vacuum pump exhaust line, air compressor intake line, evacuation, and medical vacuum slide bracket.

MAIN WATER SIZING SCHEDULE and BUILDING SYSTEM PRESSURE. Includes tables for cold and hot water systems, building system pressure, and rainwater/stormwater sizing.

RAINWATER & STORMWATER SIZING. Tables for horizontal piping and roof drain & vertical piping.

WATER SOFTENER SCHEDULE. Table with columns for model, service flow, max. grains, softener tank size, and service pipe size.

GENERAL NOTES. List of notes regarding civil drawings, contractor responsibilities, and installation requirements.

UNLESS SPECIFICALLY SHOWN ON THESE PLANS NO STRUCTURAL MEMBER SHALL BE CUT, EITHER DRILLED NOR NOTCHED. WRITTEN AUTHORIZATION FROM SOR AND USHPD DSE IS REQUIRED IN ADVANCE.

PLUMBING ABBREVIATIONS. Table listing plumbing symbols and their descriptions.

MEDICAL GAS SCHEDULE. Table listing medical gas symbols and descriptions.

MEDICAL GAS LEGEND. Table listing medical gas symbols and descriptions.

MEDICAL GAS EQUIPMENT SCHEDULE. Table listing medical gas equipment symbols and descriptions.

WATER HEATER SCHEDULE. Table listing water heater symbols and descriptions.

RECIRC. BALANCING VALVE SCHEDULE. Table listing recirculating valve symbols and descriptions.

PUMP SCHEDULE. Table listing pump symbols and descriptions.

FIXTURE CONNECTION SCHEDULE. Table listing fixture connection symbols and descriptions.

MEDICAL GAS LEGEND (continued). Table listing medical gas symbols and descriptions.

PLUMBING LEGEND. Table listing plumbing symbols and descriptions.

PLUMBING INDEX. Table listing plumbing symbols and descriptions.

SURGICAL SPECIALTY HOSPITAL

ISSUE DATE: 01-22-05
Date and description table.

PO.01
PLUMBING - SCHEDULES

The source valve for the nitrogen system is located in room _____.

- A. 1C38
- B. 1C37
- C. 1C03
- D. 1C25



Now, go to the MedGas Plan for that location

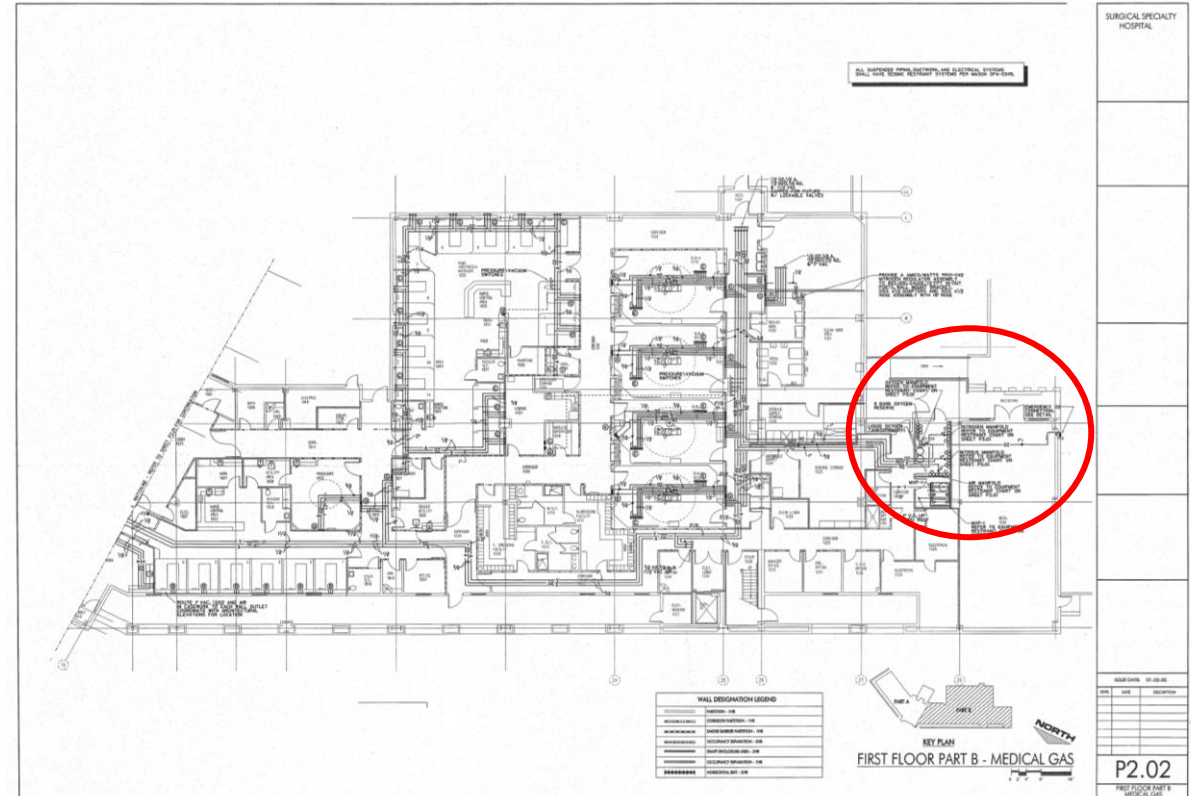
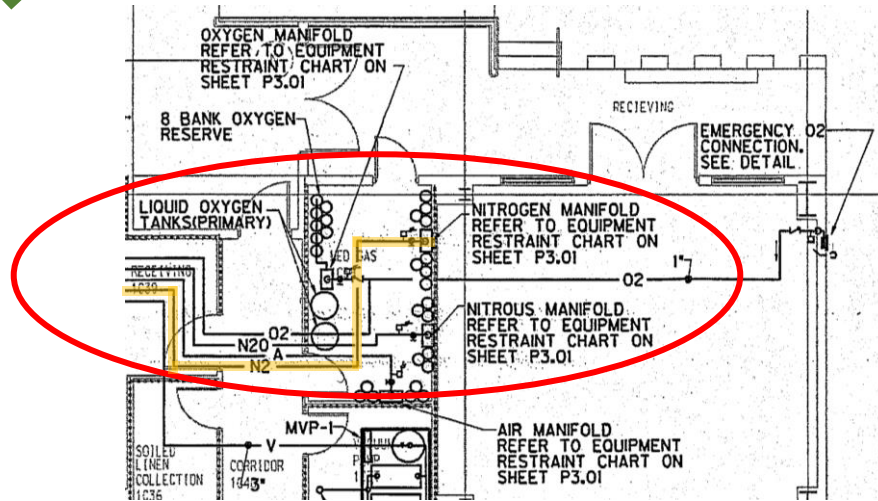

Example #3



Combination fire and smoke dampers are installed in the supply and return air duct penetrations through the wall of Electrical Room 1C26.

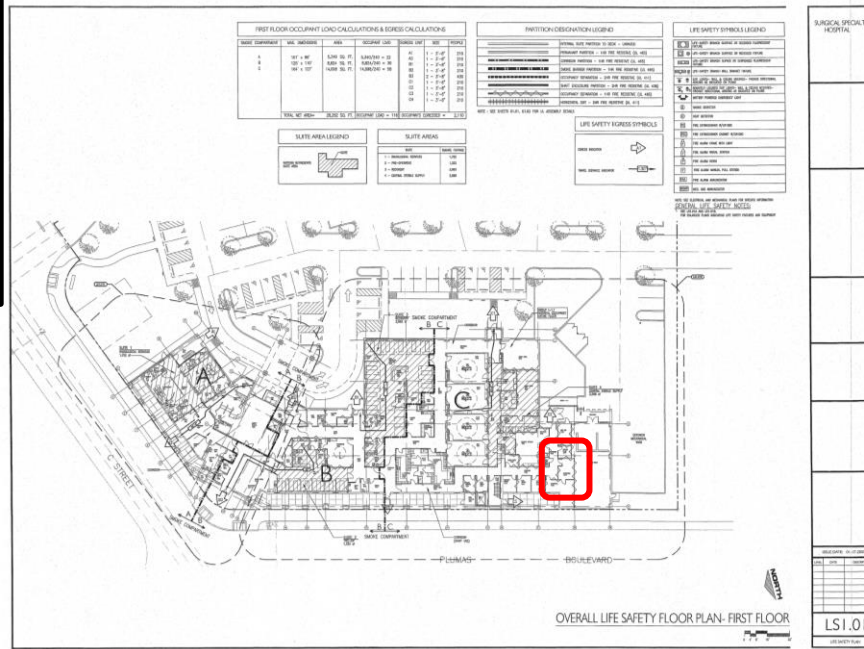

What do you have to look for?
Look for 1C26.
If you cannot find in the HVAC sheets, because the drawings are too busy.... Look in a different place, like LS1.01

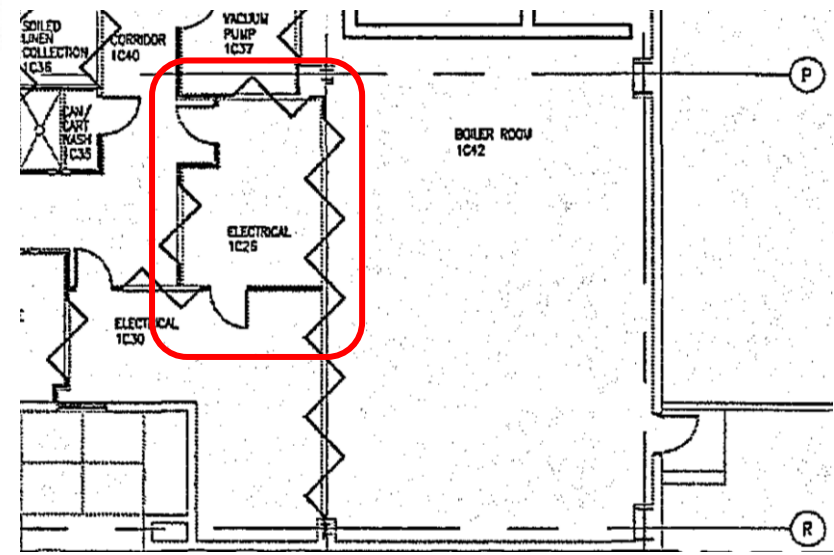

Combination fire and smoke dampers are installed in the supply and return air duct penetrations through the wall of Electrical Room 1C26.

Then, you need to look the symbol about Fire and Smoke Dampers

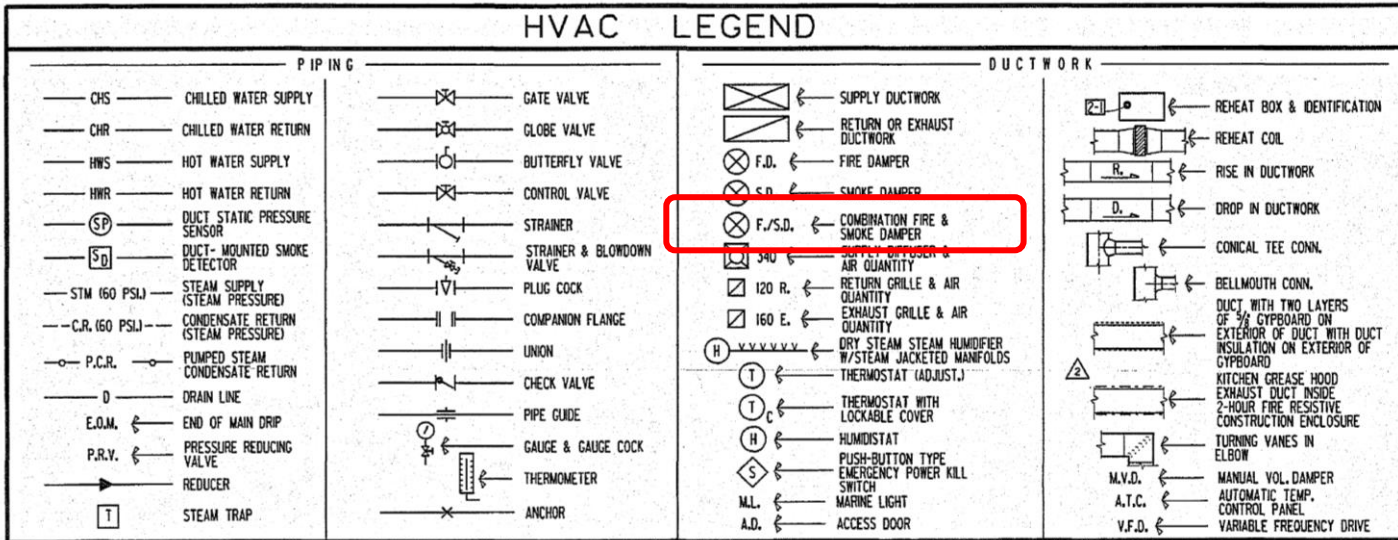

REFRIGERATION MACHINE SCHEDULE

STEAM BOILER SCHEDULE

REGISTER, GRILLE & DIFFUSER SCHEDULE

PUMP SCHEDULE

STEAM CONDENSATE PUMP UNIT SCHEDULE

AIR COMPRESSOR SCHEDULE

CONVERTOR SCHEDULE

UNIT HEATER SCHEDULE

MAKE-UP AIR UNIT SCHEDULE

EXPANSION TANK SCHEDULE

FUEL OIL TANK SCHEDULE

BOILER FEED UNIT SCHEDULE

HVAC LEGEND

HVAC INDEX

Combination fire and smoke dampers are installed in the supply and return air duct penetrations through the wall of Electrical Room 1C26.

- A. True
- B. False



And now, go to the HVAC plan

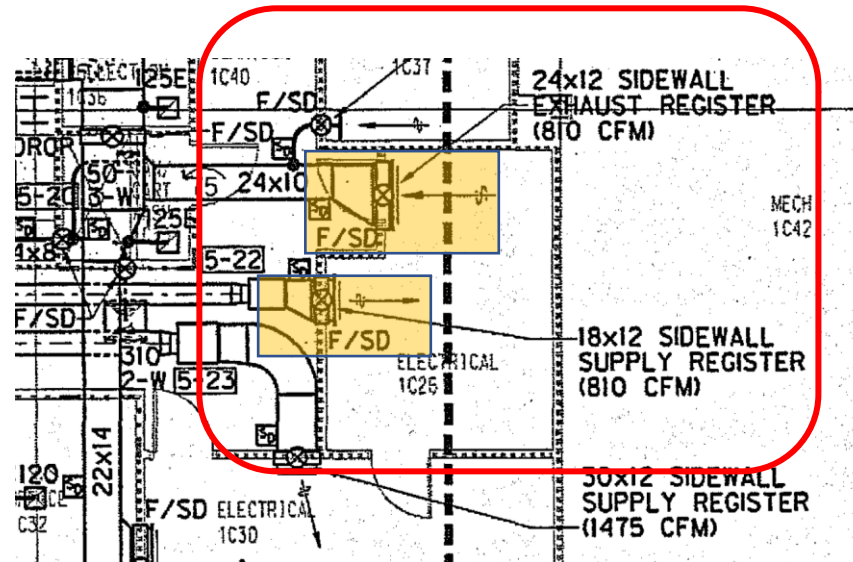
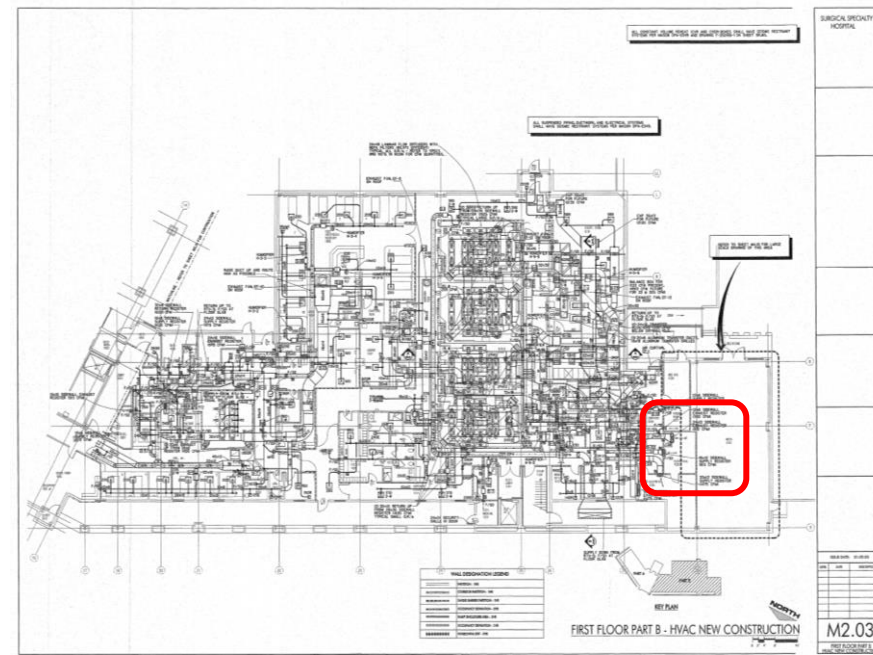

Example #4



What is the specified flow at CHWP-1?

- A. 270 GPM
- B. 400 GPM
- C. 495 GPM
- D. 1750 GPM

To find the flow for the chilled water, CHWP-1, look into the pump schedule



	GPM	FEET HEAD
4E	495	85
3E	270	80

PUMP SCHEDULE															
NOTE: 1. IF ANY POINT ON PUMP CURVE EXCEEDS THIS H.P. GO TO NEXT LARGER SIZE MOTOR AND INCLUDE PUMP MOTOR MAY BE SMALLER IF IT IS NON-OVERLOADING. QUOTE ALL CHANGES TO STARTER & ELECTRICAL WORK. 2. E.P.- EMERGENCY POWER															
ACCESSORIES ① = PROVIDE SUCTION DIFFUSER PER SECTION 15515 ② = PROVIDE PREMIUM EFFICIENCY MOTOR PER SECTION 15170 ③ = PROVIDE TRIPLE DUTY VALVE PER SECTION 15515															
QTY.	IDENT.	SYSTEM	TYPE	MANUFACTURER	MODEL NO.	GPM	FEET HEAD	MOTOR			STARTER			UNIT ACCESS.	REMARKS
								MIN. H.P.	RPM	ELEC.	TYPE	LOCATION	DISC. TYPE		
2	CHWP-1,2	CHILLED WATER	END SUCTION	B&G	SERIES 1510	495	85	20	1,750	460-3-60		FURNISHED UNDER DIV. 16	①②③		
2	CHWP-1,2	HEATING HOT WATER	END SUCTION	B&G	SERIES 1510	270	80	10	1,750	460-3-60		FURNISHED UNDER DIV. 16	①②③	E.P.	

Example #5



Supply air in lobby / waiting room 1A02 is _____ CFM.

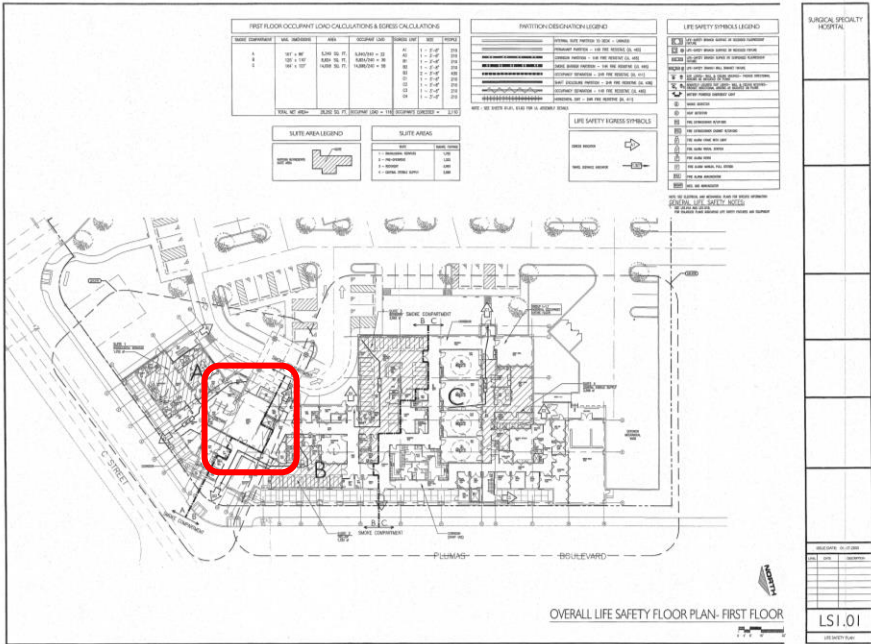

What do you have to look for?
Look for 1A02.
If you cannot find in the Mechanical sheets, because the drawings are too busy.... Look in a different place, like LS1.01

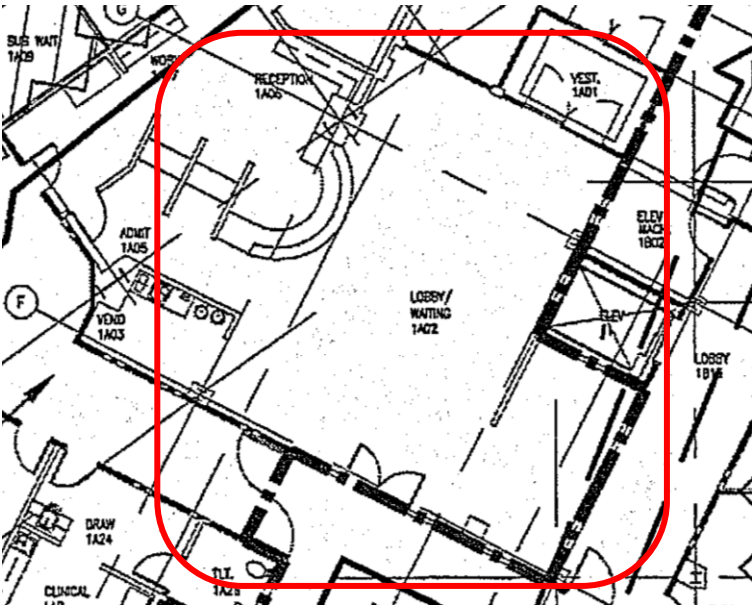

Supply air in lobby / waiting room 1A02 is _____ CFM.

Now that you know where the room is, go to the HVAC Roof Plan.

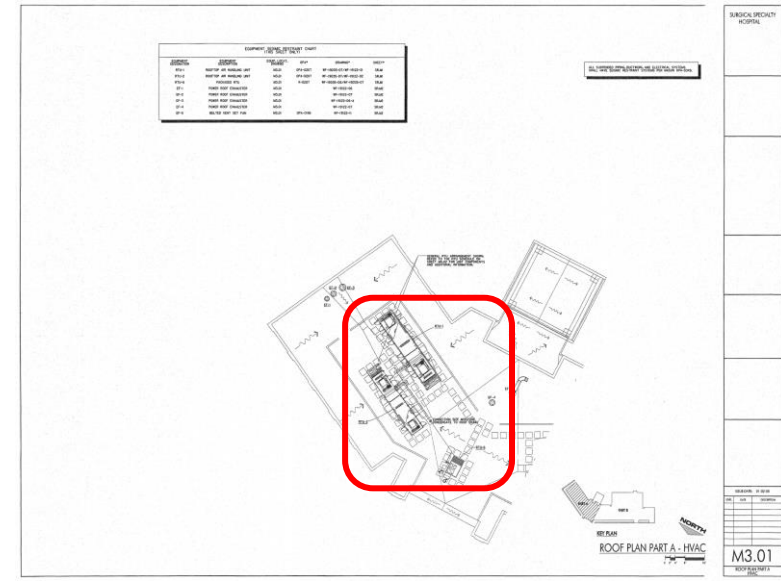
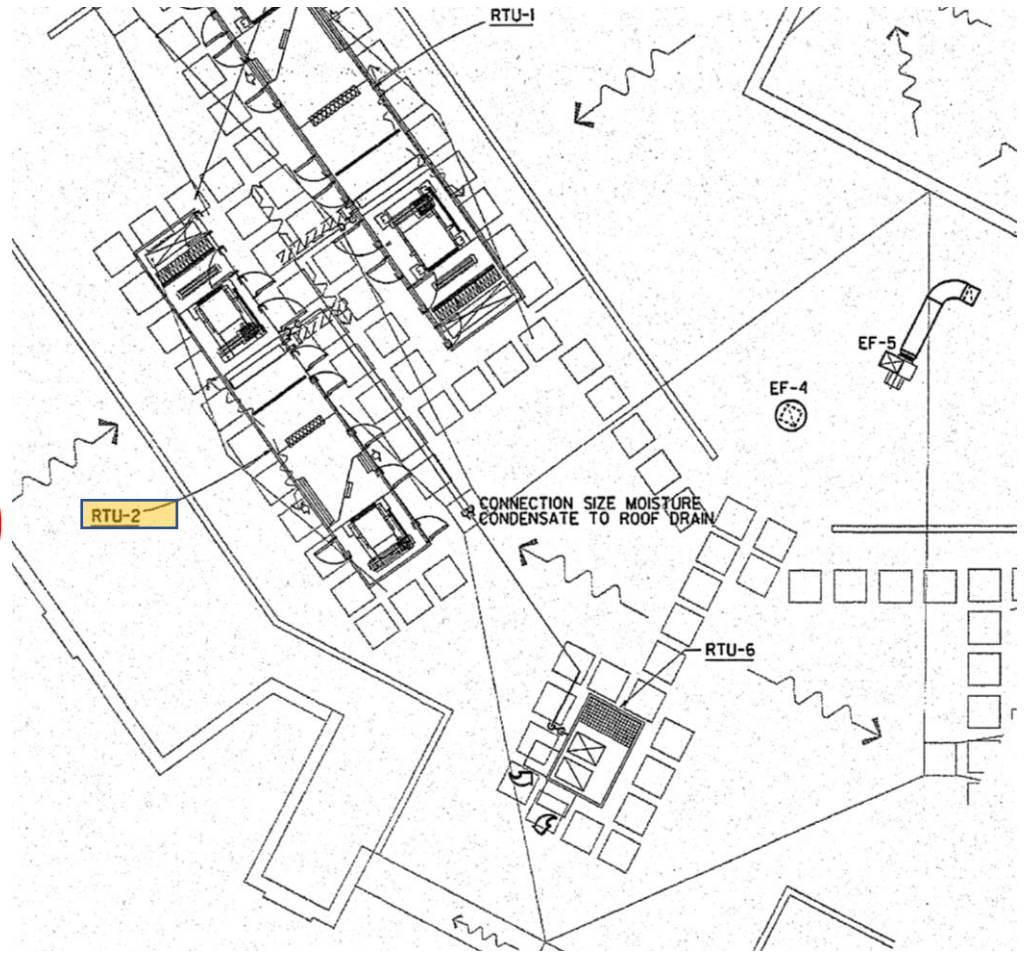

Supply air in lobby / waiting room 1A02 is _____ CFM.

A. 0
 B. 448
 C. 1,400
 D. 8,397

Knowing it is RTU-2 the unit for 1A02, go to the RTU-2 schedule, and find the Supply Air CFM information for 1A02



RTU-2 VENTILATION TABLES																		
(REFER TO SCHEDULE ON SHEET M0.02 FOR MINIMUM OUTSIDE AIR FOR UNIT)																		
ROOM NUMBER	ROOM NAME	EQUIVALENT CMC TABLE 4-A DESIGNATION	CMC MINIMUM REQUIREMENTS				DESIGN											REMARKS
			AIR BALANCE RELATIONSHIP TO ADJACENT AREAS	MINIMUM AIR CHANGES OF OUTSIDE AIR PER HOUR	MINIMUM TOTAL AIR CHANGES PER HOUR	ALL AIR EXHAUSTED DIRECTLY OUTDOORS	SPACE VOLUME (CUBIC FEET)	SUPPLY CFM	OUTSIDE AIR CFM	RETURN CFM	EXHAUST CFM	TRANSFER CFM (+POS; -NEG.)	TRANSFER ROOM NUMBER	AIR BALANCE RELATIONSHIP TO ADJACENT AREAS	AIR CHANGES OF OUTSIDE AIR PER HOUR	TOTAL SUPPLY AIR CHANGES PER HOUR	ALL AIR EXHAUSTED DIRECTLY OUTDOORS	
1A02	LOBBY/WAITING	CORRIDOR	E	2	4	N	8397	1400	448	0	0	1400	100 OUTSIDE; 1300 VENDING (OPEN AREA)	E	3.2	10.0	N	

Homework

Homework #1

Room 1A24 will transfer
100 CFM from _____.

- A. Corridor 1A28
- B. Draw 1A24
- C. None of the above
- D. Both A and B

Homework #2

What type of plumbing fixture is shown
in room 1C04?

- A. Lavatory wall hung
- B. Lavatory drop in
- C. Sink SS photo eye (staff)
- D. Sink SS (staff)



Resolution

Homework #1

Room 1A24 will transfer
100 CFM from _____.

- A. Corridor 1A28
- B. Draw 1A24
- C. None of the above
- D. Both A and B

Homework #2

What type of plumbing fixture is shown
in room 1C04?

- A. Lavatory wall hung
- B. Lavatory drop in
- C. Sink SS photo eye (staff)
- D. Sink SS (staff)



Room 1A24 will transfer
100 CFM from _____.

- A. Corridor 1A28
- B. Draw 1A24
- C. None of the above
- D. Both A and B

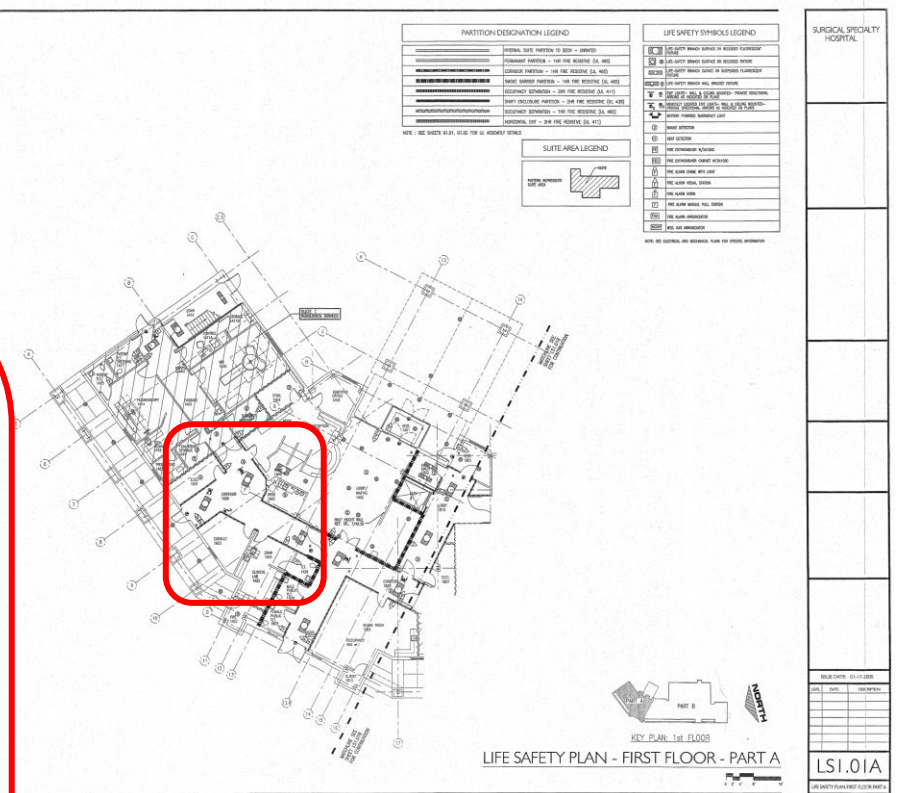
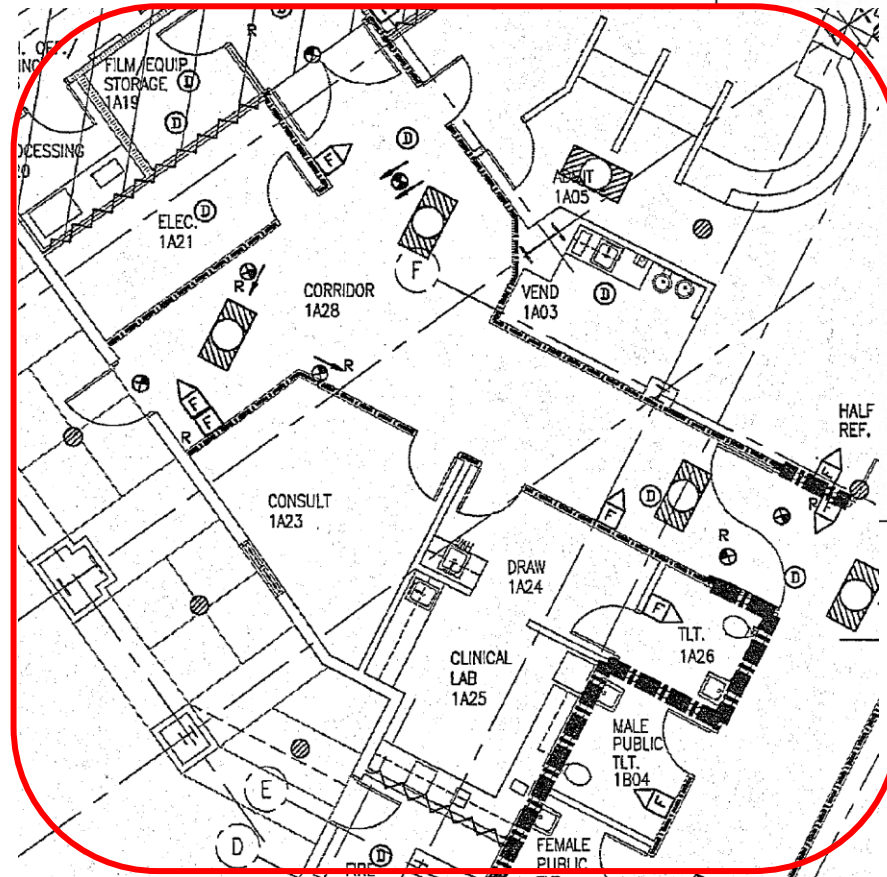

Room 1A24 will transfer
100 CFM from _____.

- A. Corridor 1A28
- B. Draw 1A24
- C. None of the above
- D. Both A and B

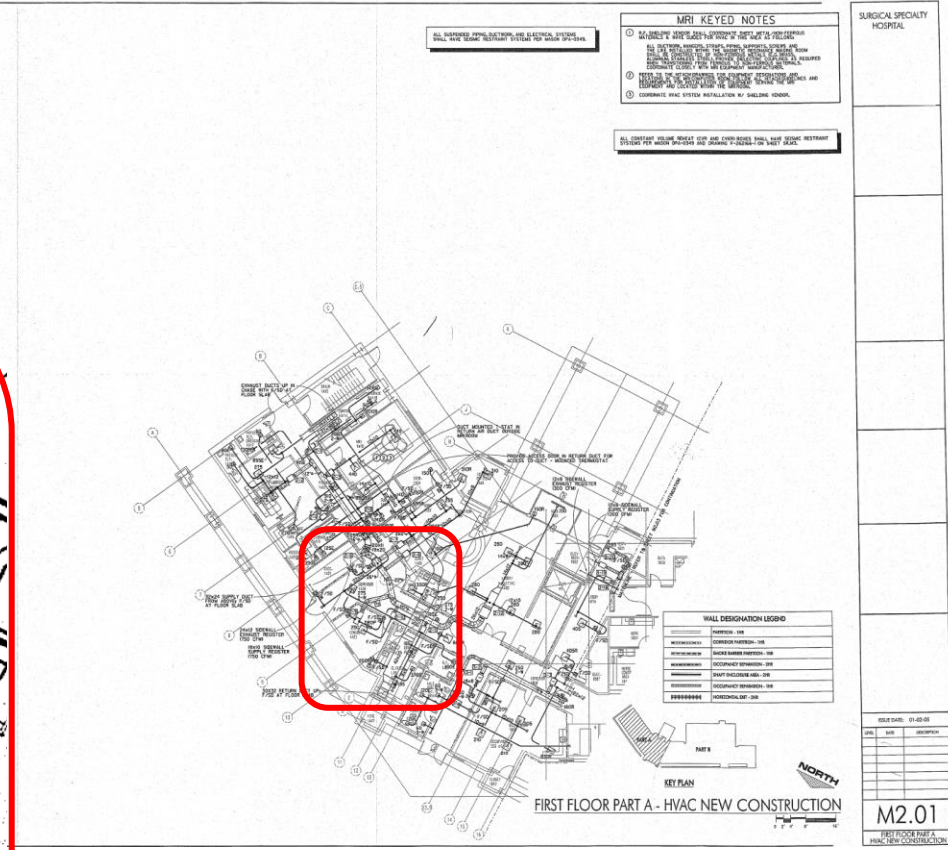
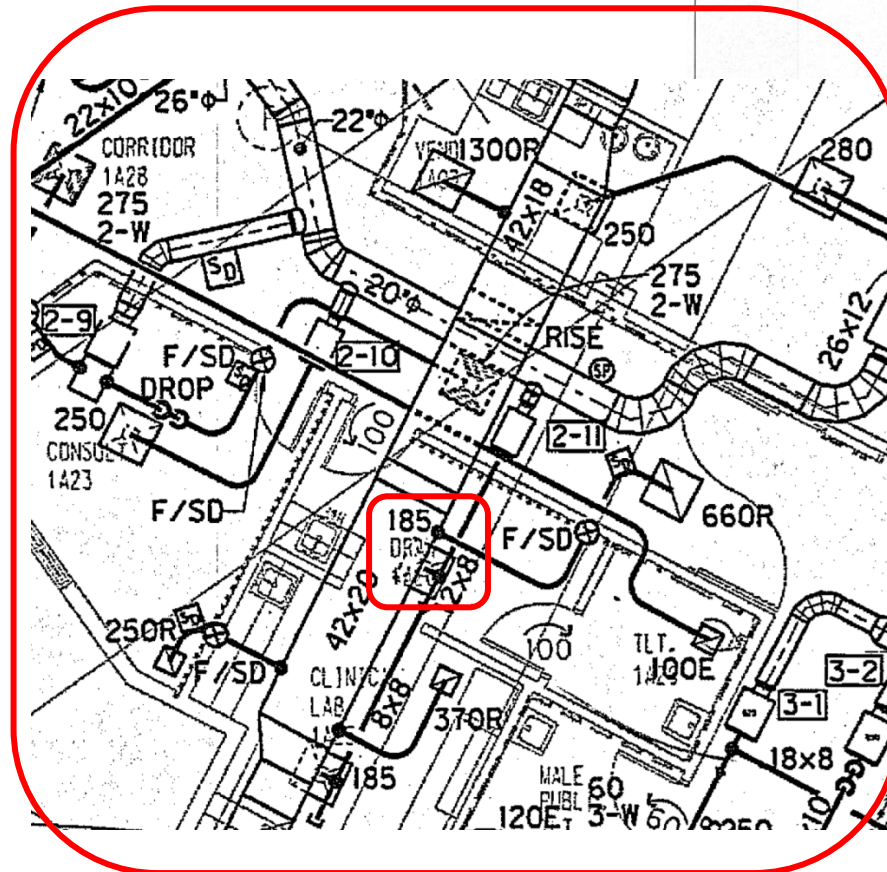

Room 1A24 will transfer
100 CFM from _____.

- A. Corridor 1A28
- B. Draw 1A24
- C. None of the above
- D. Both A and B

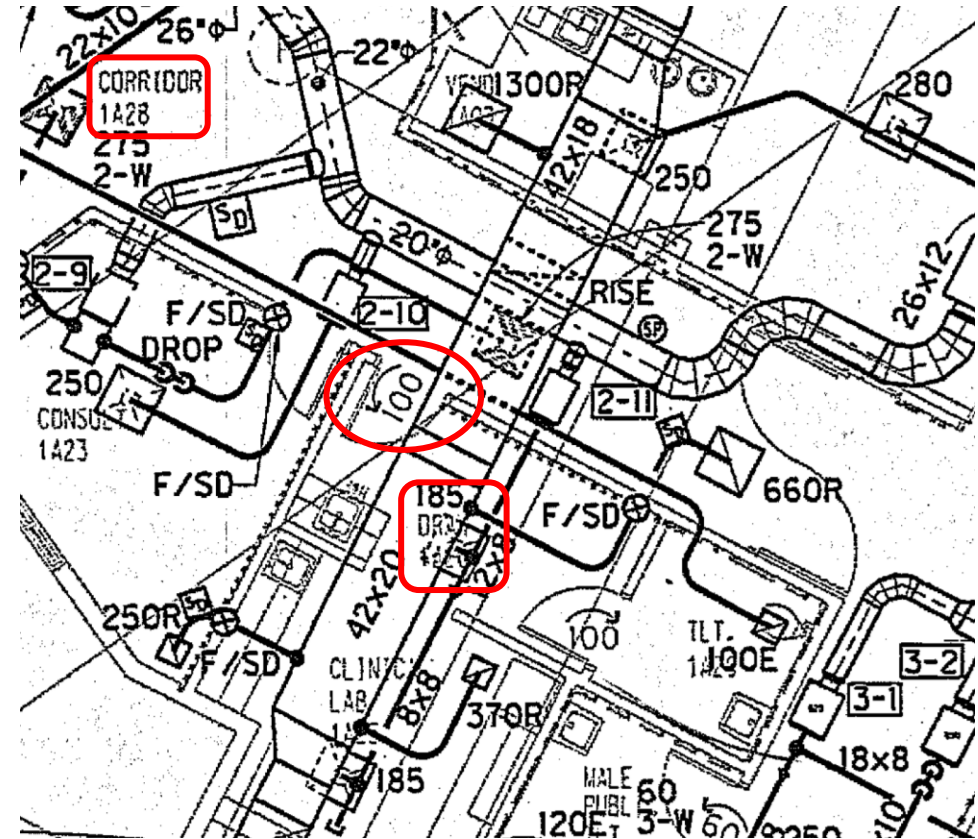
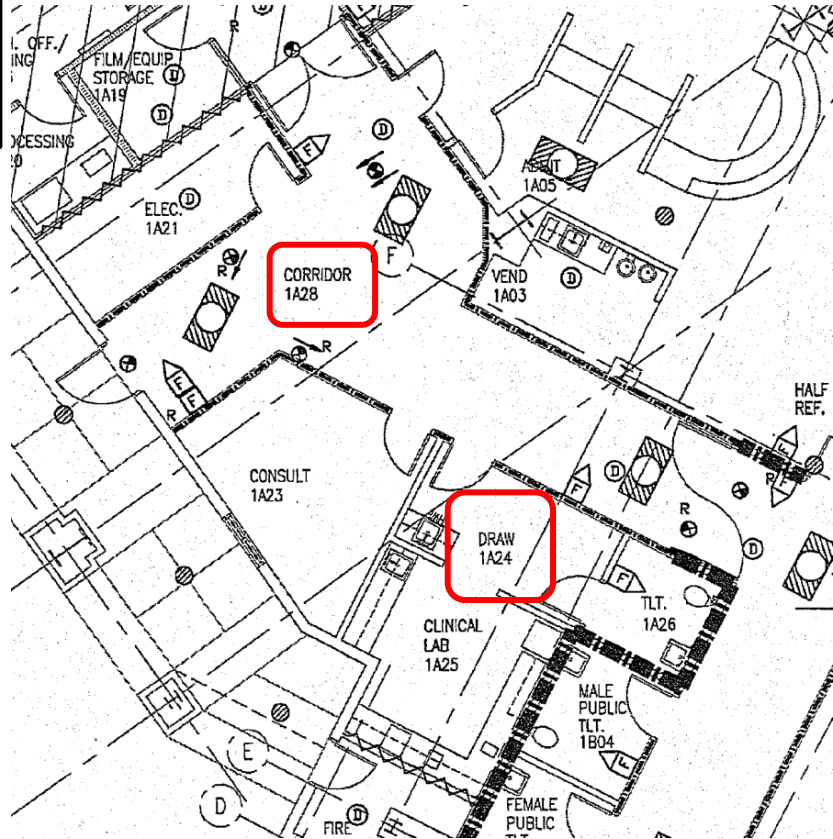

What type of plumbing fixture is shown in room 1C04?

- A. Lavatory wall hung
- B. Lavatory drop in
- C. Sink SS photo eye (staff)
- D. Sink SS (staff)

First of all, you need to go to room 1C04

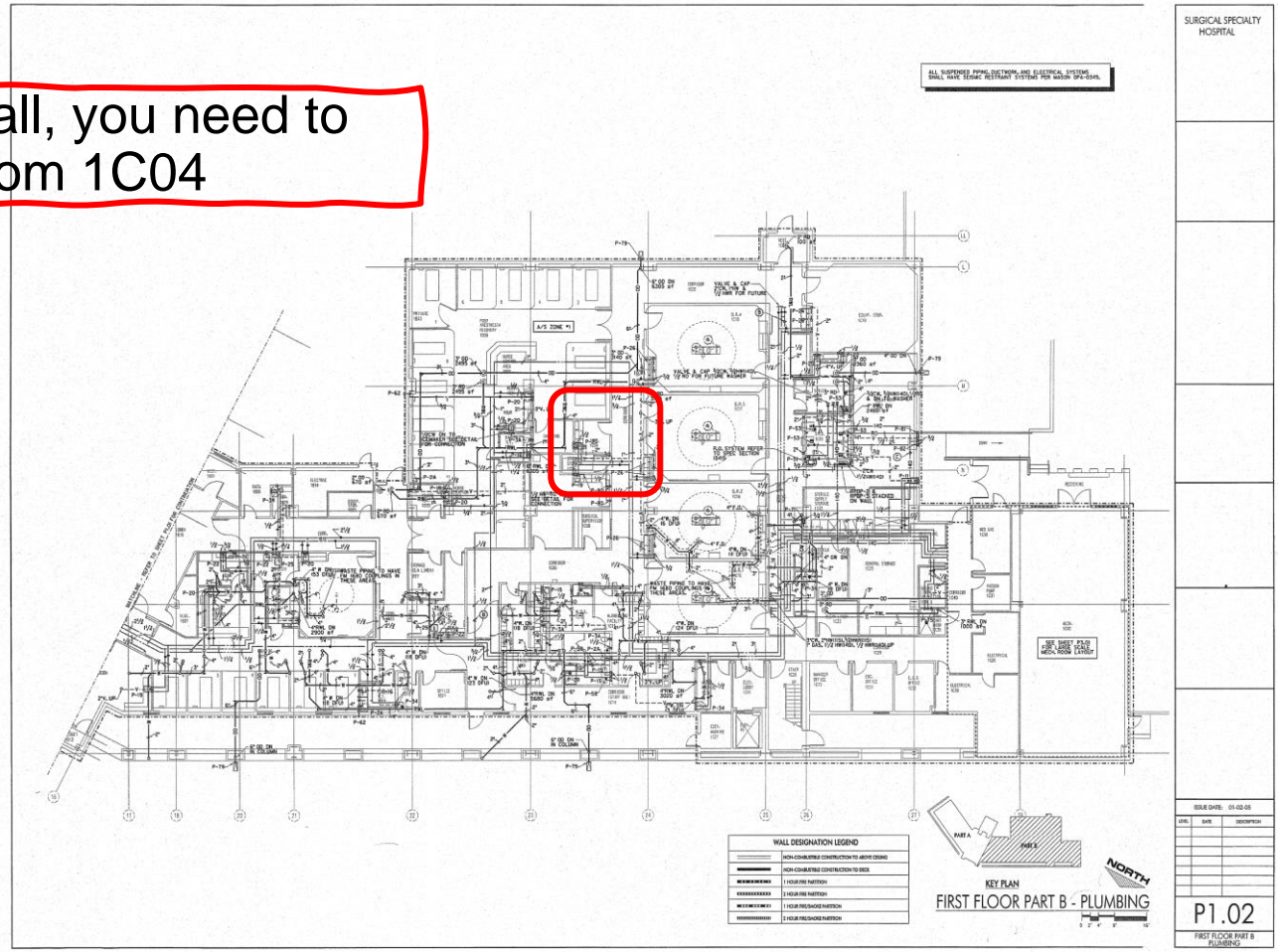
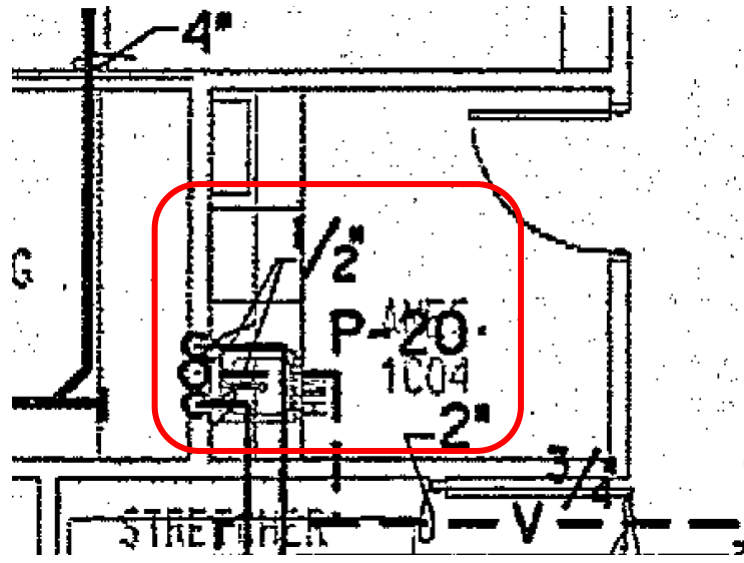

What type of plumbing fixture is shown in room 1C04?

- A. Lavatory wall hung
- B. Lavatory drop in
- C. Sink SS photo eye (staff)
- D. Sink SS (staff)

Where can you find P-20 meaning? In the Fixture schedule

The image shows a page from a plumbing specification manual. The 'FIXTURE CONNECTION SCHEDULE' table is highlighted with a red box. Other visible tables include 'MAIN WATER SIZING SCHEDULE', 'PLUMBING ABBREVIATIONS', 'MEDICAL GAS SCHEDULE', 'RAINWATER & STORMWATER SIZING', 'WATER HEATER SCHEDULE', and 'PUMP SCHEDULE'. A 'GENERAL NOTES' section is also present.

FIXTURE CONNECTION SCHEDULE						PER C.P.C. 2001 TABLE 6-3 & 7-3	
IDENTITY	FIXTURE		C.W.	H.W.	WASTE	SUPPLY FIXTURE UNITS	DRAINAGE FIXTURE UNITS
P-2A	WATER CLOSET	FLOOR MOUNTED-VALVE-PUBLIC	1"	X	4"	10	6
P-3A	WATER CLOSET	FLOOR MOUNTED-BARRIER FREE-PUBLIC	1"	X	4"	10	6
P-4A	WATER CLOSET	FLOOR MTD-BARRIER FREE-F.V.-PATIENT	1"	X	4"	6	6
P-7	URINAL	WALL HUNG-BARRIER FREE	3/4"	X	2"	5	2
P-11	LAVATORY	WALL HUNG-PHOTO EYE-STAFF	1/2"	1/2"	1 1/4"	2	1
P-12	LAVATORY	WALL HUNG-KITCHEN-FOOT OPERATED	1/2"	1/2"	1 1/4"	2	1
P-13	LAVATORY	WALL HUNG-BARRIER FREE-PUBLIC	1/2"	1/2"	1 1/4"	2	1
P-15	LAVATORY	DROP-IN-OVAL-BARRIER FREE-PUBLIC	1/2"	1/2"	1 1/4"	2	1
P-16	LAVATORY	WALL HUNG-BARRIER FREE-PATIENT	1/2"	1/2"	1 1/4"	1	1
P-17	LAVATORY	DROP-IN-OVAL-BARRIER FREE-PATIENT	1/2"	1/2"	1 1/4"	1	1
P-18	SINK	S.S.- FILM PROCESSING SINK	1/2"	1/2"	1 1/2"	2	2
P-19	SINK	S.S. - (STAFF)	1/2"	1/2"	1 1/2"	2	2
P-20	SINK	S.S. - PHOTO EYE (STAFF)	1/2"	1/2"	1 1/2"	2	2
P-22	SINK	S.S. - (STAFF)	1/2"	1/2"	1 1/2"	2	2
P-24	LAB SINK	S.S.	1/2"	1/2"	1 1/2"	2	2
P-25	CLINICAL SINK	WALL HUNG - (STAFF)	1"	1/2"	4"	10	6
P-26	SCRUB SINK	ROUGH-IN ONLY	1/2"	1/2"	1 1/2"	2	2

Electrical



Example #1



MATV outlet for floor mounted televisions shall be installed at ___ inches above finished floor.

MATV stands for Master Antenna Television. Where could you find the MATV outlet information? Look at the Index

ELECTRICAL SHEET INDEX	
SHEET NUMBER	DESCRIPTION
E0.01	ELECTRICAL INDEX AND SCHEDULES
E0.02	ELECTRICAL LEGENDS
E0.03	ELECTRICAL EQUIPMENT CONNECTION SCHEDULES
E0.04	ELECTRICAL EQUIPMENT CONNECTION SCHEDULES
E1.01	ELECTRICAL SITE PLAN
E2.01	FIRST FLOOR PLAN - PART A- LIGHTING
E2.02	FIRST FLOOR PLAN - PART B- LIGHTING
E2.03	SECOND FLOOR PLAN - PART A- LIGHTING
E2.04	SECOND FLOOR PLAN - PART B- LIGHTING
E3.01	FIRST FLOOR PLAN - PART A- POWER
E3.02	FIRST FLOOR PLAN - PART B- POWER
E3.03	SECOND FLOOR PLAN - PART A- POWER
E3.04	SECOND FLOOR PLAN - PART B- POWER
E4.01	FIRST FLOOR PLAN - PART A- SYSTEMS
E4.02	FIRST FLOOR PLAN - PART B- SYSTEMS
E4.03	SECOND FLOOR PLAN - PART A- SYSTEMS
E4.04	SECOND FLOOR PLAN - PART B- SYSTEMS
E5.01	ROOF PLAN - PART A - ELECTRICAL
E5.02	ROOF PLAN - PART B - ELECTRICAL
E6.01	LARGE SCALE ELECTRICAL
E6.02	LARGE SCALE ELECTRICAL
E7.01	ELECTRICAL POWER DISTRIBUTION RISER
E7.02	ELECTRICAL POWER DISTRIBUTION NORMAL ONE LINE DIAGRAM
E7.03	ELECTRICAL POWER DISTRIBUTION ESSENTIAL ONE LINE DIAGRAM
E7.04	ELECTRICAL POWER DISTRIBUTION ESSENTIAL ONE LINE DIAGRAM
E8.01	TELECOMMUNICATIONS DETAILS
E8.02	ELECTRICAL DETAILS
E9.01	ELECTRICAL PANELBOARD SCHEDULES - NORMAL SYSTEM
E9.02	ELECTRICAL PANELBOARD SCHEDULES - ESSENTIAL SYSTEM
E9.03	ELECTRICAL PANELBOARD SCHEDULES - ESSENTIAL SYSTEM

LIGHTING FIXTURE SCHEDULE						
TYPE	MANUFACTURER	CATALOG NO.	LAMPS	VOLT	MOUNTING	REMARKS
1	COLUMBIA	182-22-000-0711	3-32W T8	277V	RECESSED	RECESSED 2" HONEY COMB LAMP BY THE END OF THE LINE
2	COLUMBIA	182-22-075-0711	3-32W T8	277V	RECESSED	RECESSED 2" HONEY COMB LAMP
3	COLUMBIA	182-22-075-0711	3-32W T8	277V	RECESSED	RECESSED 2" HONEY COMB LAMP
4	COLUMBIA	182-22-075-0711	3-32W T8	277V	RECESSED	RECESSED 2" HONEY COMB LAMP
5	COLUMBIA	182-22-075-0711	3-32W T8	277V	RECESSED	RECESSED 2" HONEY COMB LAMP
6	PRESCULITE	182-22-075-0711	3-32W T8	277V	RECESSED	RECESSED 2" HONEY COMB LAMP
7	SHALITE	182-22-075-0711	3-32W T8	277V	RECESSED	RECESSED 2" HONEY COMB LAMP
8	SHALITE	182-22-075-0711	3-32W T8	277V	RECESSED	RECESSED 2" HONEY COMB LAMP
9	COLUMBIA	182-22-075-0711	3-32W T8	277V	RECESSED	RECESSED 2" HONEY COMB LAMP
10	COLUMBIA	182-22-075-0711	3-32W T8	277V	RECESSED	RECESSED 2" HONEY COMB LAMP
11	COLUMBIA	182-22-075-0711	3-32W T8	277V	RECESSED	RECESSED 2" HONEY COMB LAMP
12	ALICO	182-22-075-0711	3-32W T8	277V	RECESSED	RECESSED 2" HONEY COMB LAMP
13	ALICO	182-22-075-0711	3-32W T8	277V	RECESSED	RECESSED 2" HONEY COMB LAMP
14	ADVENT	182-22-075-0711	3-32W T8	277V	RECESSED	RECESSED 2" HONEY COMB LAMP
15	ALICO	182-22-075-0711	3-32W T8	277V	RECESSED	RECESSED 2" HONEY COMB LAMP
16	ALICO	182-22-075-0711	3-32W T8	277V	RECESSED	RECESSED 2" HONEY COMB LAMP
17	ALICO	182-22-075-0711	3-32W T8	277V	RECESSED	RECESSED 2" HONEY COMB LAMP
18	PRESCULITE	182-22-075-0711	3-32W T8	277V	RECESSED	RECESSED 2" HONEY COMB LAMP
19	PRESCULITE	182-22-075-0711	3-32W T8	277V	RECESSED	RECESSED 2" HONEY COMB LAMP
20	SELESTAL	182-22-075-0711	3-32W T8	277V	RECESSED	RECESSED 2" HONEY COMB LAMP
21	COLUMBIA	182-22-075-0711	3-32W T8	277V	RECESSED	RECESSED 2" HONEY COMB LAMP
22	PRESCULITE	182-22-075-0711	3-32W T8	277V	RECESSED	RECESSED 2" HONEY COMB LAMP
23	PRESCULITE	182-22-075-0711	3-32W T8	277V	RECESSED	RECESSED 2" HONEY COMB LAMP
24	COLUMBIA	182-22-075-0711	3-32W T8	277V	RECESSED	RECESSED 2" HONEY COMB LAMP
25	SHALITE	182-22-075-0711	3-32W T8	277V	RECESSED	RECESSED 2" HONEY COMB LAMP
26	PRESCULITE	182-22-075-0711	3-32W T8	277V	RECESSED	RECESSED 2" HONEY COMB LAMP
27	COLUMBIA	182-22-075-0711	3-32W T8	277V	RECESSED	RECESSED 2" HONEY COMB LAMP
28	ALICO	182-22-075-0711	3-32W T8	277V	RECESSED	RECESSED 2" HONEY COMB LAMP
29	SHALITE	182-22-075-0711	3-32W T8	277V	RECESSED	RECESSED 2" HONEY COMB LAMP
30	COLUMBIA	182-22-075-0711	3-32W T8	277V	RECESSED	RECESSED 2" HONEY COMB LAMP
31	SHALITE	182-22-075-0711	3-32W T8	277V	RECESSED	RECESSED 2" HONEY COMB LAMP
32	COLUMBIA	182-22-075-0711	3-32W T8	277V	RECESSED	RECESSED 2" HONEY COMB LAMP
33	PRESCULITE	182-22-075-0711	3-32W T8	277V	RECESSED	RECESSED 2" HONEY COMB LAMP
34	ALICO	182-22-075-0711	3-32W T8	277V	RECESSED	RECESSED 2" HONEY COMB LAMP
35	COLUMBIA	182-22-075-0711	3-32W T8	277V	RECESSED	RECESSED 2" HONEY COMB LAMP
36	COLUMBIA	182-22-075-0711	3-32W T8	277V	RECESSED	RECESSED 2" HONEY COMB LAMP
37	SH	182-22-075-0711	3-32W T8	277V	RECESSED	RECESSED 2" HONEY COMB LAMP
38	SH	182-22-075-0711	3-32W T8	277V	RECESSED	RECESSED 2" HONEY COMB LAMP
39	SH	182-22-075-0711	3-32W T8	277V	RECESSED	RECESSED 2" HONEY COMB LAMP
40	SH	182-22-075-0711	3-32W T8	277V	RECESSED	RECESSED 2" HONEY COMB LAMP
41	PRESCULITE	182-22-075-0711	3-32W T8	277V	RECESSED	RECESSED 2" HONEY COMB LAMP
42	SH	182-22-075-0711	3-32W T8	277V	RECESSED	RECESSED 2" HONEY COMB LAMP
43	ALICO	182-22-075-0711	3-32W T8	277V	RECESSED	RECESSED 2" HONEY COMB LAMP
44	ALICO	182-22-075-0711	3-32W T8	277V	RECESSED	RECESSED 2" HONEY COMB LAMP
45	ALICO	182-22-075-0711	3-32W T8	277V	RECESSED	RECESSED 2" HONEY COMB LAMP
46	PRESCULITE	182-22-075-0711	3-32W T8	277V	RECESSED	RECESSED 2" HONEY COMB LAMP
47	SH	182-22-075-0711	3-32W T8	277V	RECESSED	RECESSED 2" HONEY COMB LAMP
48	PRESCULITE	182-22-075-0711	3-32W T8	277V	RECESSED	RECESSED 2" HONEY COMB LAMP
49	PRESCULITE	182-22-075-0711	3-32W T8	277V	RECESSED	RECESSED 2" HONEY COMB LAMP
50	ADVENT	182-22-075-0711	3-32W T8	277V	RECESSED	RECESSED 2" HONEY COMB LAMP
51	PRESCULITE	182-22-075-0711	3-32W T8	277V	RECESSED	RECESSED 2" HONEY COMB LAMP
52	SH	182-22-075-0711	3-32W T8	277V	RECESSED	RECESSED 2" HONEY COMB LAMP
53	SELESTAL	182-22-075-0711	3-32W T8	277V	RECESSED	RECESSED 2" HONEY COMB LAMP
54	SH	182-22-075-0711	3-32W T8	277V	RECESSED	RECESSED 2" HONEY COMB LAMP
55	SH	182-22-075-0711	3-32W T8	277V	RECESSED	RECESSED 2" HONEY COMB LAMP

ELECTRICAL SHEET INDEX	
SHEET NUMBER	DESCRIPTION
E0.01	ELECTRICAL INDEX AND SCHEDULES
E0.02	ELECTRICAL LEGENDS
E0.03	ELECTRICAL EQUIPMENT CONNECTION SCHEDULES
E0.04	ELECTRICAL EQUIPMENT CONNECTION SCHEDULES
E1.01	ELECTRICAL SITE PLAN
E2.01	FIRST FLOOR PLAN - PART A- LIGHTING
E2.02	FIRST FLOOR PLAN - PART B- LIGHTING
E2.03	SECOND FLOOR PLAN - PART A- LIGHTING
E2.04	SECOND FLOOR PLAN - PART B- LIGHTING
E3.01	FIRST FLOOR PLAN - PART A- POWER
E3.02	FIRST FLOOR PLAN - PART B- POWER
E3.03	SECOND FLOOR PLAN - PART A- POWER
E3.04	SECOND FLOOR PLAN - PART B- POWER
E4.01	FIRST FLOOR PLAN - PART A- SYSTEMS
E4.02	FIRST FLOOR PLAN - PART B- SYSTEMS
E4.03	SECOND FLOOR PLAN - PART A- SYSTEMS
E4.04	SECOND FLOOR PLAN - PART B- SYSTEMS
E5.01	ROOF PLAN - PART A - ELECTRICAL
E5.02	ROOF PLAN - PART B - ELECTRICAL
E6.01	LARGE SCALE ELECTRICAL
E6.02	LARGE SCALE ELECTRICAL
E7.01	ELECTRICAL POWER DISTRIBUTION RISER
E7.02	ELECTRICAL POWER DISTRIBUTION NORMAL ONE LINE DIAGRAM
E7.03	ELECTRICAL POWER DISTRIBUTION ESSENTIAL ONE LINE DIAGRAM
E7.04	ELECTRICAL POWER DISTRIBUTION ESSENTIAL ONE LINE DIAGRAM
E8.01	TELECOMMUNICATIONS DETAILS
E8.02	ELECTRICAL DETAILS
E9.01	ELECTRICAL PANELBOARD SCHEDULES - NORMAL SYSTEM
E9.02	ELECTRICAL PANELBOARD SCHEDULES - ESSENTIAL SYSTEM
E9.03	ELECTRICAL PANELBOARD SCHEDULES - ESSENTIAL SYSTEM

HVAC FIRE ALARM SHUTDOWN SCHEDULE		
REV	DATE	DESCRIPTION
1	01-10-00	ISSUE
2	01-10-00	REVISED
3	01-10-00	REVISED
4	01-10-00	REVISED
5	01-10-00	REVISED
6	01-10-00	REVISED
7	01-10-00	REVISED
8	01-10-00	REVISED
9	01-10-00	REVISED
10	01-10-00	REVISED

FOR REMOVAL OF EQUIPMENT REFER TO THE SHEET NOTES IN THESE SHEETS FOR THE LOCATION OF EQUIPMENT. THE CONSTRUCTION DOCUMENTS.

SURGICAL SPECIALTY HOSPITAL

ISSUE DATE: 01-10-00

REV: DATE: DISPOSITION

E0.01

ELECTRICAL INDEX AND SCHEDULES

MATV outlet for floor mounted televisions shall be installed at ___ inches above finished floor.

Probably, the information could be where patient rooms are E4.04

ELECTRICAL NOTES

- 1 INTERCOM STATION SHALL RING AT MASTER STATION INSIDE PHARMACY.
- 2 FIRE ALARM ZONE ADDRESSABLE UNIT FOR INTERFACE WITH KITCHEN EXHAUST HOOD AND ANSUL SYSTEM. REFER TO DIVISION 15 AND 16 SPECIFICATIONS AND COORDINATE WITH EQUIPMENT VENDOR PRIOR TO ROUGH-IN.
- 3 PATIENT ROOM CEILING MOUNTED SMOKE DETECTORS SHALL BE CONNECTED TO BUILDING FIRE ALARM SYSTEM AND ANNUNCIATE AT NURSE CALL DOME LIGHT OUTSIDE EACH ROOM. REFER TO DIVISION 16 AND 17 SPECIFICATIONS FOR ADDITIONAL INFORMATION.
- 4 REFER TO ARCHITECTURAL ELEVATIONS FOR EXACT MOUNTING LOCATION OF NURSE CALL AND TELECOMMUNICATION DEVICES IN HEADWALL.
- 5 FIRE ALARM RELAY PROVIDED FOR INTERFAACE OF AUTOMATIC DOOR OPERATOR.
- 6 FIRE ALARM RELAY PROVIDED FOR INTERFAACE WITH GAS SOLENOID SHUTOFF. COORDINATE WITH DIVISION 15.

- ELECTRICAL NOTES**
- 1 INTERCOM STATION SHALL RING AT MASTER STATION INSIDE PHARMACY.
 - 2 FIRE ALARM ZONE ADDRESSABLE UNIT FOR INTERFACE WITH KITCHEN EXHAUST HOOD AND ANSUL SYSTEM. REFER TO DIVISION 15 AND 16 SPECIFICATIONS AND COORDINATE WITH EQUIPMENT VENDOR PRIOR TO ROUGH-IN.
 - 3 PATIENT ROOM CEILING MOUNTED SMOKE DETECTORS SHALL BE CONNECTED TO BUILDING FIRE ALARM SYSTEM AND ANNUNCIATE AT NURSE CALL DOME LIGHT OUTSIDE EACH ROOM. REFER TO DIVISION 16 AND 17 SPECIFICATIONS FOR ADDITIONAL INFORMATION.
 - 4 REFER TO ARCHITECTURAL ELEVATIONS FOR EXACT MOUNTING LOCATION OF NURSE CALL AND TELECOMMUNICATION DEVICES IN HEADWALL.
 - 5 FIRE ALARM RELAY PROVIDED FOR INTERFAACE OF AUTOMATIC DOOR OPERATOR.
 - 6 FIRE ALARM RELAY PROVIDED FOR INTERFAACE WITH GAS SOLENOID SHUTOFF. COORDINATE WITH DIVISION 15.

- GENERAL FIRE ALARM NOTES**
- REFER TO DIVISION 16 PLANS FOR EXACT LOCATIONS AND QUANTITIES OF FIRE ALARM SMOKE MOUNTED SMOKE DETECTOR DEVICES SHOWN ON PLAN ARE FOR REFERENCE ONLY.
- REFER TO FIRE SUPPRESSOR VENDOR PLANS FOR LOCATIONS OF FIRE ALARM CHIMES AND FLOW SWITCHES.
- REFER TO FIRE ALARM VENDOR PLANS FOR PROJECT'S ROUTING, FIRE ALARM CONTROL AND NOTIFICATION PANEL LOCATIONS AND SIZINGS.
- REFER TO DIVISION 16 SPECIFICATIONS FOR ADDITIONAL FIRE ALARM REQUIREMENTS AND INFORMATION.

ALL SUSPENDED PIPING, DUCTWORK, AND ELECTRICAL SYSTEMS SHALL HAVE SEISMIC RESTRAINT SYSTEMS PER MASON OPA-0549.

FOR SEISMIC RESTRAINT OF EQUIPMENT SHOWN ON THIS SHEET, REFER TO CHART SHOWN ON SHEET E2-03 FOR LOCATION OF ANCHORAGE DETAILS INCLUDED IN THE CONSTRUCTION DOCUMENTS.

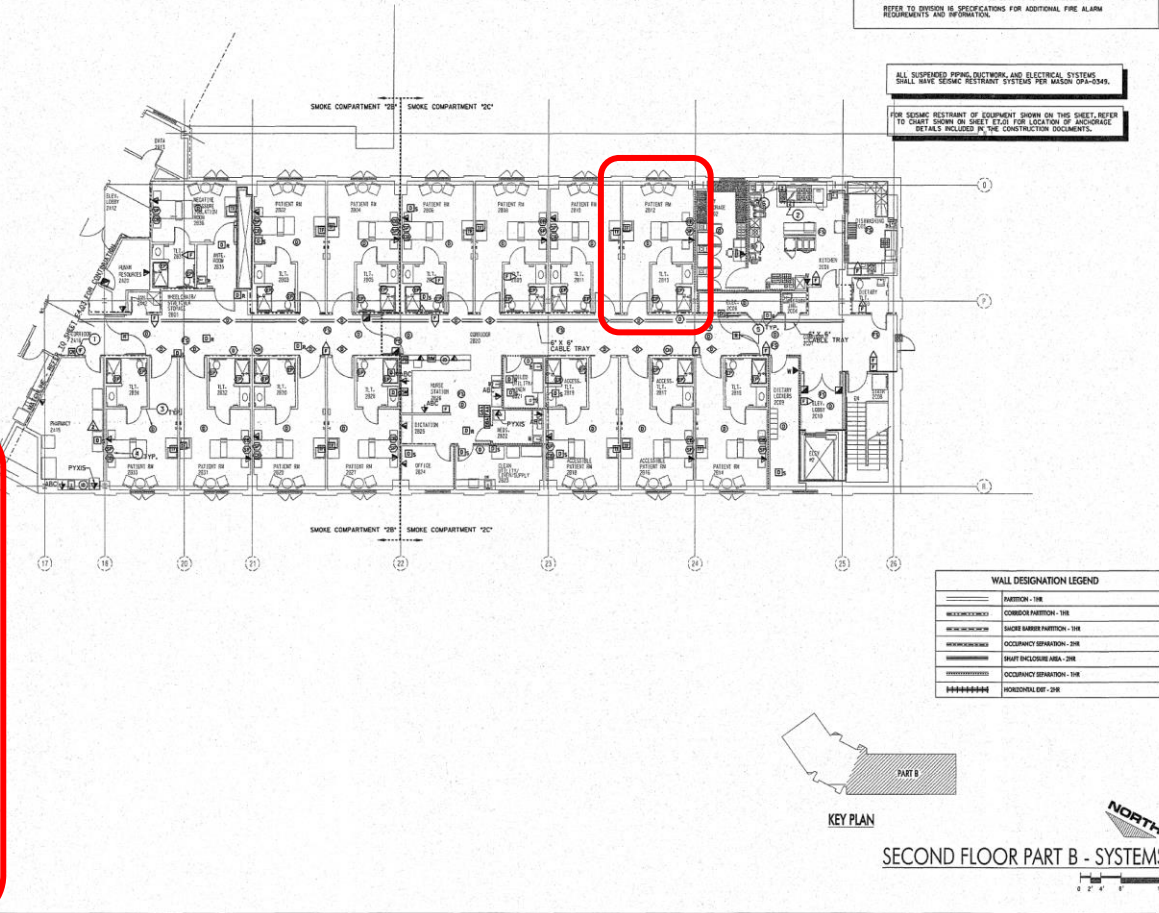
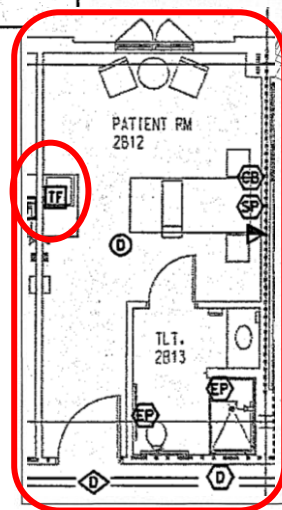
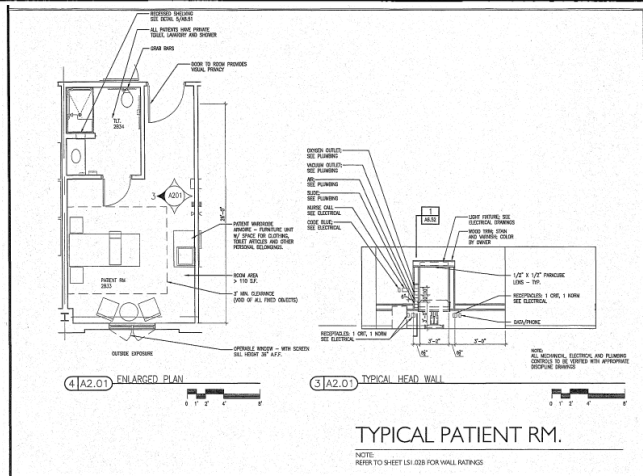

SURGICAL SPECIALTY HOSPITAL

ISSUE DATE: 01-22-05

REV.	DATE	DESCRIPTION

E4.04

SECOND FLOOR PART B SYSTEMS

MATV outlet for floor mounted televisions shall be installed at ___ inches above finished floor.

- A. 12
- B. 18
- C. 24
- D. 30



So, let's look at the legend sheet E0.02

LEGEND		
SYMBOL	DESCRIPTION	MOUNTING HEIGHT
CABLE/MATV SYSTEM		
TF	MATV OUTLET FOR FLOOR MOUNTED TV (ANTENNA, & REMOTE CONTROL SEE MANUFACTURERS DETAIL)	1' - 6" AFF

The image shows three copies of the legend sheet E0.02. The first copy has a red circle around the 'CABLE/MATV SYSTEM' section, which contains the entry for the MATV outlet. The second copy has a red circle around the 'TELEPHONE' section. The third copy has a red circle around the 'POWER RECEPTACLE' section. The legend sheet includes various symbols and their corresponding descriptions and mounting heights for different systems like Fire Alarm, Security, and Telephone.

Example #2



A _____ shall be used as the steam sterilizer control disconnecting means for the steam sterilizers serving the O.R. area.

In order to find the steam sterilizer information, it is necessary to look for the sterilizer room location. Look, for example, LS1.01

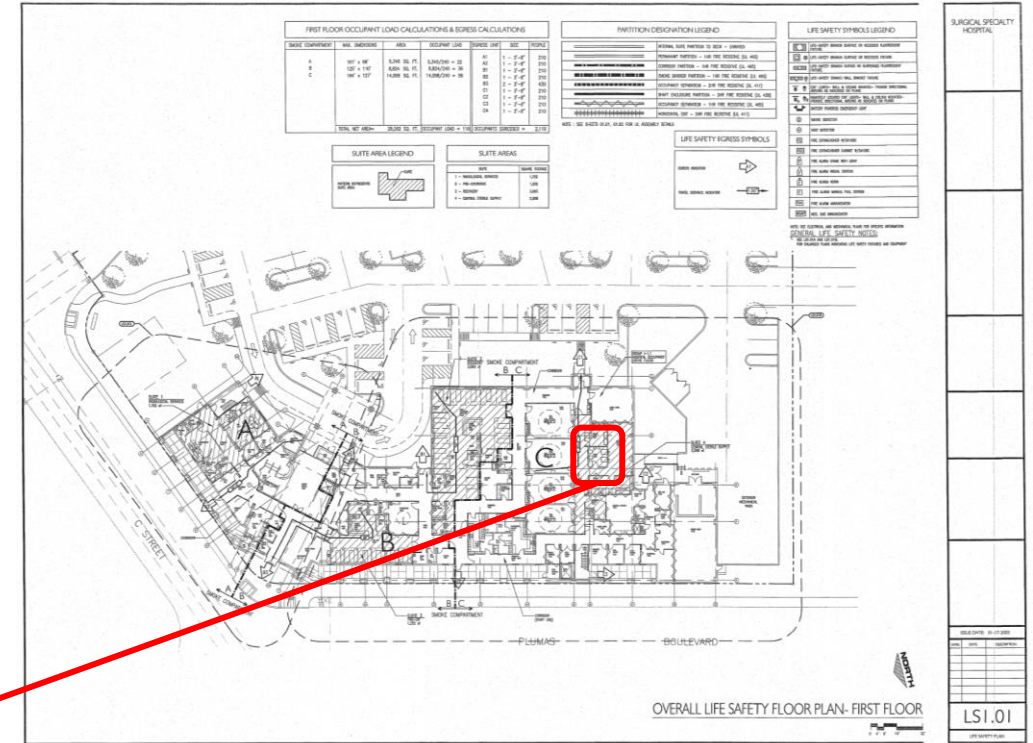
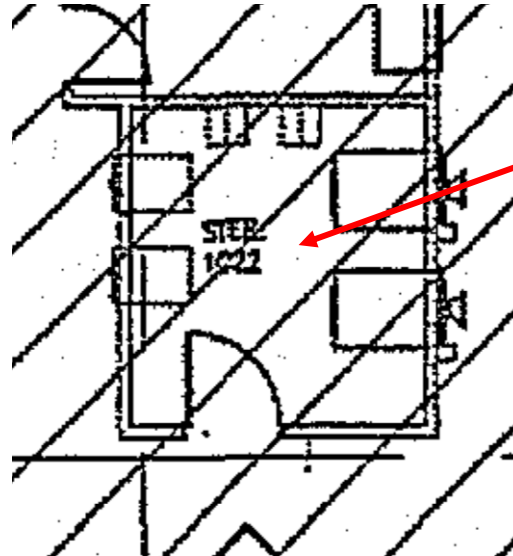

A _____ shall be used as the steam sterilizer control disconnecting means for the steam sterilizers serving the O.R. area.

- A. 30A non fused disconnect switch
- B. 30A fused disconnect switch
- C. single pole 20A switch
- D. single pole 15A switch



Now that you know where 1C22 is, look into the electrical sheets, and find the information

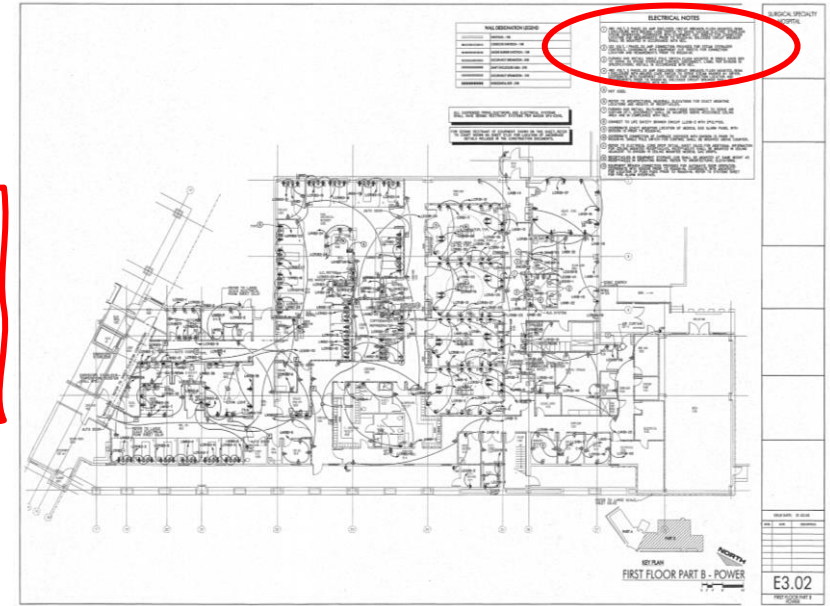

ELECTRICAL NOTES

- ① 480 VOLT, 3 PHASE, 50 AMP ENCLOSED CIRCUIT BREAKER, FLUSH MOUNTED, NEMA 1 ENCLOSURE WITH MOLDED CASE SWITCH TO SERVE VACUUM ELECTRIC STERILIZER STEAM GENERATOR. COORDINATE WITH EQUIPMENT CUT SHEETS FOR CONNECTION LOCATION AND REQUIREMENTS PRIOR TO ROUGH-IN. ENCLOSED CIRCUIT BREAKER SHALL BE MOUNTED IN ACCORDANCE WITH NEC.
- ② 120 VOLT, 1 PHASE, 20 AMP CONNECTION PROVIDED FOR STEAM STERILIZER CONTROLS. COORDINATE WITH EQUIPMENT CUT SHEETS FOR CONNECTION LOCATION AND REQUIREMENTS PRIOR TO ROUGH-IN.
- ③ FURNISH AND INSTALL SINGLE POLE SWITCH, FLUSH MOUNTED IN SINGLE GANG BOX TO SERVE AS STEAM STERILIZER CONTROL DISCONNECT. LABEL PER DIVISION 16 SPECIFICATIONS. INSTALL IN ACCORDANCE WITH NEC.



Example #3



Mechanical unit RTU-6 shall be fed using a ____V, __ pole, ____ Amp circuit breaker.

RTU stands for Roof Top Unit.
Look the Electrical Roof Plan to see the Panel for RTU-6

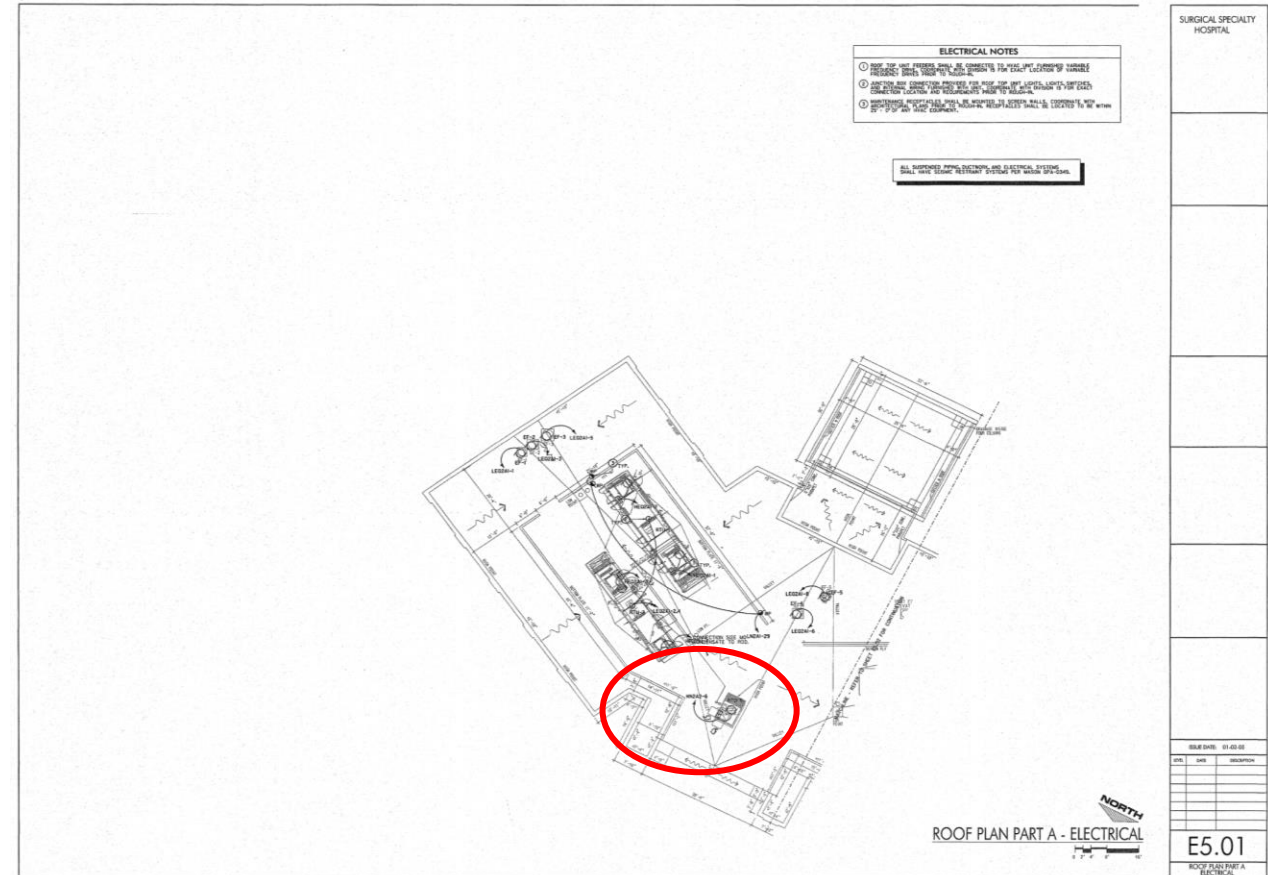
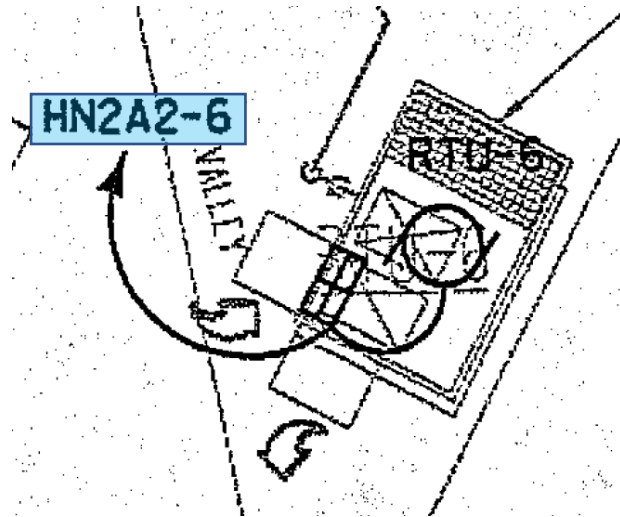

Mechanical unit RTU-6 shall be fed using a ____ V, ____ pole, ____ Amp circuit breaker.

- A. 480, 3, 15
- B. 120, 1, 20
- C. 208, 3, 30
- D. 277, 1, 20



ELECTRICAL ROOM "2A02"

PANEL: HN2A2		DC DEVICE TYPE: Breaker		ENCLOSURE: NEMA 1		MAINS(A): MLO		BUS RATING(A): 225				
LOCATION: ELECTRIC CLOSET 2A02		DEVICE FAMILY: Bolt On		WIRING: Sur-100		WIRING: 3-Phase 4-Wire		WITHSTAND(A): 10000				
FED FROM: HN2A1 BUS				VOLTAGE: 480/277				FAULT CURRENT(A) 5596				
CKT	DESCRIPTION	NOTES	DEMAND CODE	VA	DC AMPS P	PHASE	DC AMPS P	VA	DEMAND CODE	NOTES	DESCRIPTION	CKT
1	TENANT LIGHTING	2#12.1#12G	NON CDN LGT	2460	20 1	A	20 1	0	SPARE		SPARE	2
3	TENANT LIGHTING	2#12.1#12G	NON CDN LGT	2220	20 1	B	20 1	0	SPARE		SPARE	4
5	DDC 5-1 REHEAT UNIT	3#12.1#12G	HEAT	6900	15 3	C	15 3	3391	MTR	3#12.1#12G	RTU-6	5
7	"	"	"	"	"	"	"	"	"	"	"	9
11	DDC 5-3 REHEAT UNIT	3#12.1#12G	HEAT	6500	15 3	C	20 3	12700	HEAT	3#12.1#12G	DDC 6-2 REHEAT UNIT	12
13	"	"	"	"	"	A	"	"	"	"	"	14
15	"	"	"	"	"	B	"	"	"	"	"	16
17	DDC 5-5 REHEAT UNIT	3#12.1#12G	HEAT	2500	15 3	C	20 3	10000	HEAT	3#12.1#12G	DDC 6-4 REHEAT UNIT	18
19	"	"	"	"	"	A	"	"	"	"	"	20
21	"	"	"	"	"	B	"	"	"	"	"	22
23	DDC 5-6 REHEAT UNIT	3#12.1#12G	HEAT	6000	15 3	C	15 3	2500	HEAT	3#12.1#12G	DDC 6-7 REHEAT UNIT	24
25	"	"	"	"	"	A	"	"	"	"	"	26
27	"	"	"	"	"	B	"	"	"	"	"	28
29	SPARE		SPARE	0	20 1	C	20 1	0	SPARE		SPARE	30
31	SPARE		SPARE	0	20 1	A	20 1	0	SPARE		SPARE	32
33	SPARE		SPARE	0	20 1	B	20 1	0	SPARE		SPARE	34
35	SPACE		SPACE	0	20 1	C	20 1	0	SPARE		SPARE	36
37	SPACE		SPACE	0	20 1	A	50 3	12780	NONE	SEE ONE-LINE	TN2A2 PRI BUS	38
39	SPACE		SPACE	0	20 1	B	"	"	"	"	"	40
41	SPACE		SPACE	0	20 1	C	"	"	"	"	"	42
ALL CONNECTED				KVA	AMPS	* PHASE TOTALS		VA	AMPS	BUS TOTALS		KVA
TOTAL CONNECTED				68.55	86.2	* A-N		23900.4	86.2	CONNECTED		68.55
TOTAL DEMAND				20.06	27.6	* B-N		23480.9	84.7	DEMAND		20.06
TOTAL DESIGN				20.06	27.6	* C-N		21170.5	76.4	DESIGN		20.06

Note: Another way is to start from the panel schedule without knowing the Panel ID, and to search RTU-6, however it's more time-consuming.

Example #4



How many light fixtures in patient room 2B12 are required to have dimmer switches?

Prior to read how many dimmer switches are in 2B12, find the symbol for them in the Switches legend.

SWITCHES		
S	SINGLE POLE SWITCH - IVORY TOGGLE	3'-10" AFF TO CL.
\$	SINGLE POLE SWITCH - RED TOGGLE	3'-10" AFF TO CL.
S ₂	DOUBLE POLE SWITCH - CENTER OFF	3'-10" AFF TO CL.
S ₃	THREE WAY SWITCH - IVORY TOGGLE	3'-10" AFF TO CL.
S ₄	FOUR WAY SWITCH - IVORY TOGGLE	3'-10" AFF TO CL.
S _D	DIMMER SWITCH	3'-10" AFF TO CL.
VIC	VARIABLE INTENSITY CONTROL	3'-10" AFF TO CL.
ST	MOTOR RATED SWITCH WITH THERMAL OVERLOAD	_____
P	PUSH PAD SWITCH FOR AUTOMATIC DOOR OPERATOR	3'-10" AFF TO CL.
\$P	SINGLE POLE SWITCH WITH PILOT LIGHT	_____
SS	MULTI-LEVEL SWITCHING, (2) TWO SINGLE POLE SWITCHES CONNECT (1) SWITCH TO EACH BALLAST IN FIXTURE	3'-10" AFF TO CL.
OS	OCCUPANCY SENSOR (REFER TO DIVISION 16 SPECIFICATIONS)	CEILING

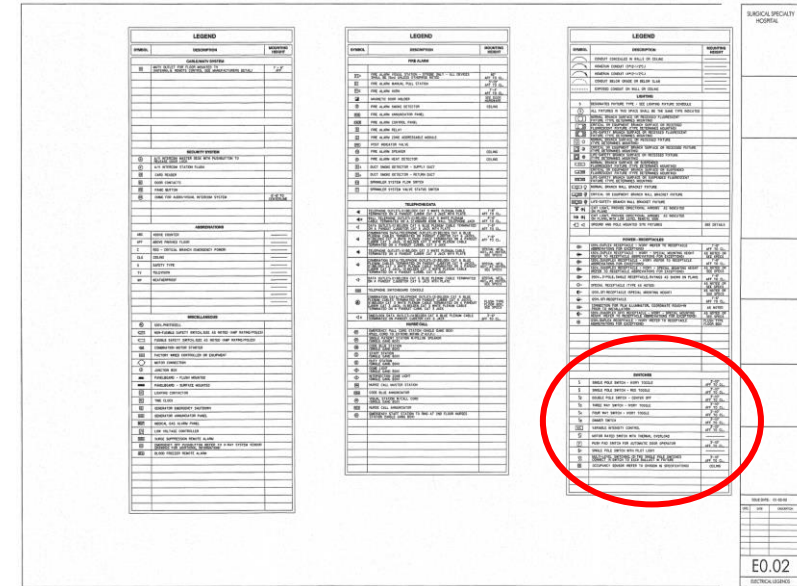

How many light fixtures in patient room 2B12 are required to have dimmer switches?

- A. 1
- B. 2
- C. 3
- D. none

Now that you know that the symbol is SD, look in 2B12

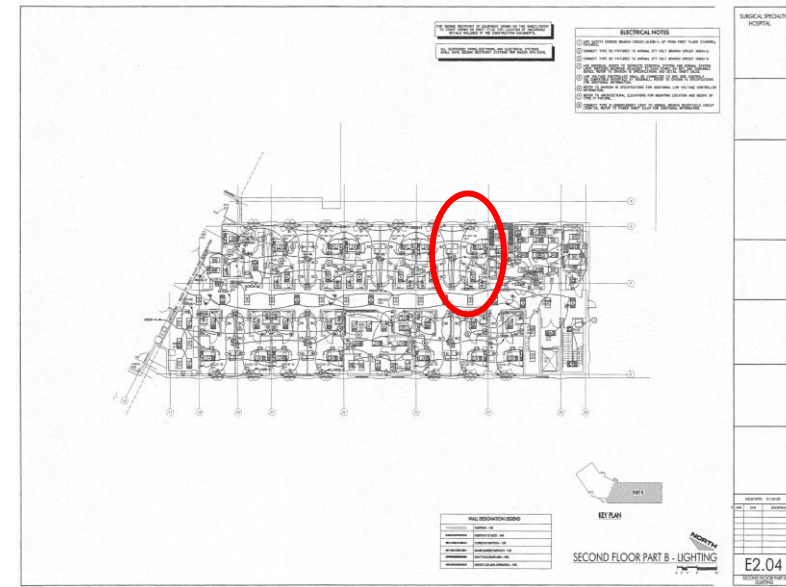
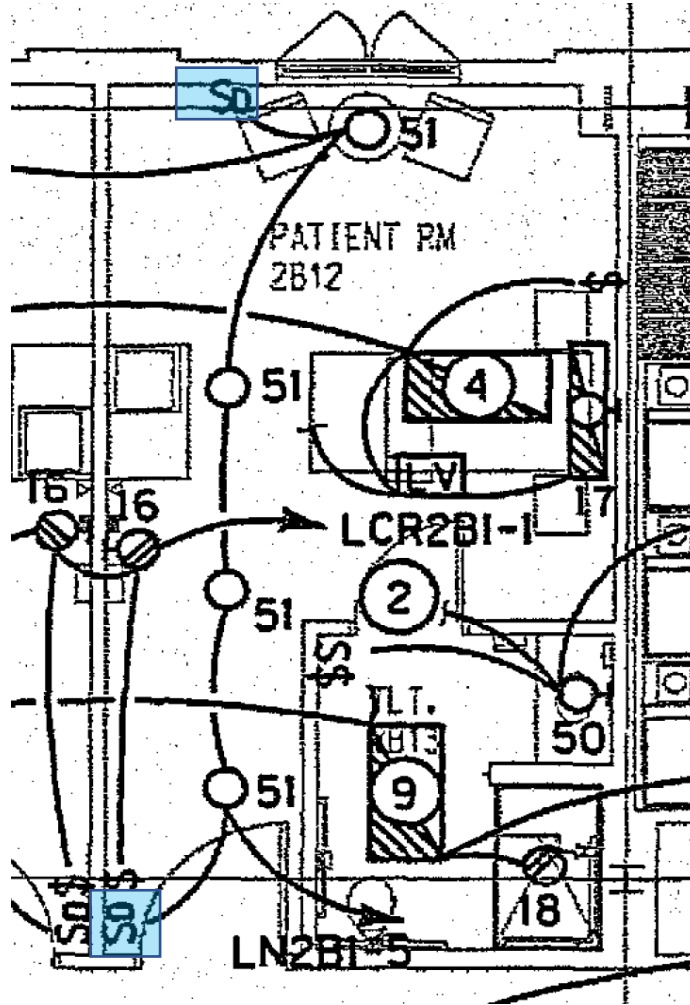

Example #5



The concrete base for light pole fixture #38 shall be provided with _____ vert. reinforcing bars & #3 ties @ 12" and extend _____ feet below grade.

For light pole information, you should look into the Electrical Site Plan

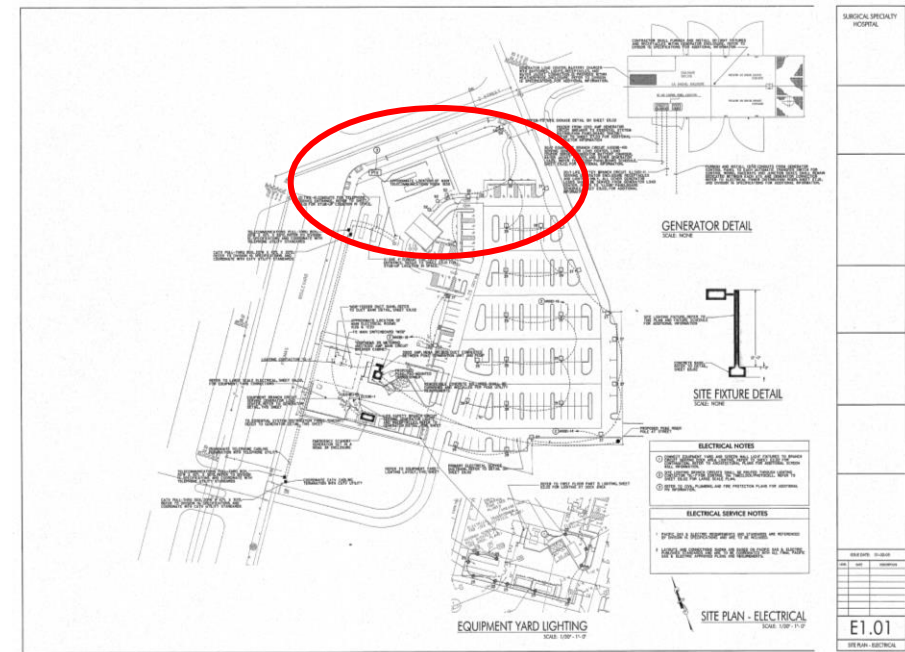
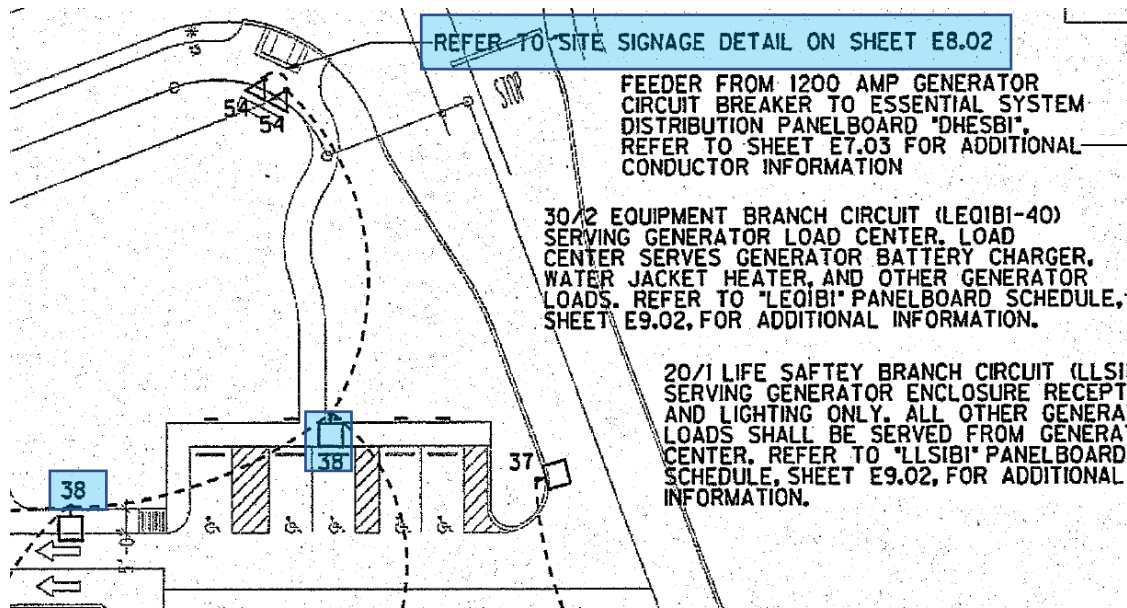

The concrete base for light pole fixture #38 shall be provided with _____ vert. reinforcing bars & #3 ties @ 12" and extend _____ feet below grade.

In the Electrical Schedule, look for the Light Fixture 38 for information, like the height...

LIGHTING FIXTURE SCHEDULE						
TYPE	MANUFACTURER	CATALOG NO.	LAMPS	VOLT	MOUNTING	REMARKS
1	COLUMBIA	ET4-ET4-PRS12	2-250W MH	277	RECESSED	ALUMINUM, 2 LAMP, W/ CLEAR ALUM. LENSES
2	COLUMBIA	ET4-ET4-PRS12	2-250W MH	277	RECESSED	ALUMINUM, 2 LAMP, W/ CLEAR ALUM. LENSES
3	COLUMBIA	ET4-ET4-PRS12	2-250W MH	277	RECESSED	ALUMINUM, 2 LAMP, W/ CLEAR ALUM. LENSES
4	COLUMBIA	ET4-ET4-PRS12	2-250W MH	277	RECESSED	ALUMINUM, 2 LAMP, W/ CLEAR ALUM. LENSES
5	COLUMBIA	ET4-ET4-PRS12	2-250W MH	277	RECESSED	ALUMINUM, 2 LAMP, W/ CLEAR ALUM. LENSES
6	PRESCLITE	ET4-ET4-PRS12	2-250W MH	277	RECESSED	ALUMINUM, 2 LAMP, W/ CLEAR ALUM. LENSES
7	QUANTE	ET4-ET4-PRS12	2-250W MH	277	RECESSED	ALUMINUM, 2 LAMP, W/ CLEAR ALUM. LENSES
8	QUANTE	ET4-ET4-PRS12	2-250W MH	277	RECESSED	ALUMINUM, 2 LAMP, W/ CLEAR ALUM. LENSES
9	COLUMBIA	ET4-ET4-PRS12	2-250W MH	277	RECESSED	ALUMINUM, 2 LAMP, W/ CLEAR ALUM. LENSES
10	COLUMBIA	ET4-ET4-PRS12	2-250W MH	277	RECESSED	ALUMINUM, 2 LAMP, W/ CLEAR ALUM. LENSES
11	COLUMBIA	ET4-ET4-PRS12	2-250W MH	277	RECESSED	ALUMINUM, 2 LAMP, W/ CLEAR ALUM. LENSES
12	ALCO	ET4-ET4-PRS12	2-250W MH	277	RECESSED	ALUMINUM, 2 LAMP, W/ CLEAR ALUM. LENSES
13	ALCO	ET4-ET4-PRS12	2-250W MH	277	RECESSED	ALUMINUM, 2 LAMP, W/ CLEAR ALUM. LENSES
14	ADVENT	ET4-ET4-PRS12	2-250W MH	277	RECESSED	ALUMINUM, 2 LAMP, W/ CLEAR ALUM. LENSES
15	ALCO	ET4-ET4-PRS12	2-250W MH	277	RECESSED	ALUMINUM, 2 LAMP, W/ CLEAR ALUM. LENSES
16	ALCO	ET4-ET4-PRS12	2-250W MH	277	RECESSED	ALUMINUM, 2 LAMP, W/ CLEAR ALUM. LENSES
17	ALCO	ET4-ET4-PRS12	2-250W MH	277	RECESSED	ALUMINUM, 2 LAMP, W/ CLEAR ALUM. LENSES
18	PRESCLITE	ET4-ET4-PRS12	2-250W MH	277	RECESSED	ALUMINUM, 2 LAMP, W/ CLEAR ALUM. LENSES
19	PRESCLITE	ET4-ET4-PRS12	2-250W MH	277	RECESSED	ALUMINUM, 2 LAMP, W/ CLEAR ALUM. LENSES
20	CELESTIAL	ET4-ET4-PRS12	2-250W MH	277	RECESSED	ALUMINUM, 2 LAMP, W/ CLEAR ALUM. LENSES
21	COLUMBIA	ET4-ET4-PRS12	2-250W MH	277	RECESSED	ALUMINUM, 2 LAMP, W/ CLEAR ALUM. LENSES
22	PRESCLITE	ET4-ET4-PRS12	2-250W MH	277	RECESSED	ALUMINUM, 2 LAMP, W/ CLEAR ALUM. LENSES
23	PRESCLITE	ET4-ET4-PRS12	2-250W MH	277	RECESSED	ALUMINUM, 2 LAMP, W/ CLEAR ALUM. LENSES
24	COLUMBIA	ET4-ET4-PRS12	2-250W MH	277	RECESSED	ALUMINUM, 2 LAMP, W/ CLEAR ALUM. LENSES
25	MURRELL	ET4-ET4-PRS12	2-250W MH	277	RECESSED	ALUMINUM, 2 LAMP, W/ CLEAR ALUM. LENSES
26	PRESCLITE	ET4-ET4-PRS12	2-250W MH	277	RECESSED	ALUMINUM, 2 LAMP, W/ CLEAR ALUM. LENSES
27	COLUMBIA	ET4-ET4-PRS12	2-250W MH	277	RECESSED	ALUMINUM, 2 LAMP, W/ CLEAR ALUM. LENSES
28	COLUMBIA	ET4-ET4-PRS12	2-250W MH	277	RECESSED	ALUMINUM, 2 LAMP, W/ CLEAR ALUM. LENSES
29	ALPHA	ET4-ET4-PRS12	2-250W MH	277	RECESSED	ALUMINUM, 2 LAMP, W/ CLEAR ALUM. LENSES
30	COLUMBIA	ET4-ET4-PRS12	2-250W MH	277	RECESSED	ALUMINUM, 2 LAMP, W/ CLEAR ALUM. LENSES
31	MURRELL	ET4-ET4-PRS12	2-250W MH	277	RECESSED	ALUMINUM, 2 LAMP, W/ CLEAR ALUM. LENSES
32	COLUMBIA	ET4-ET4-PRS12	2-250W MH	277	RECESSED	ALUMINUM, 2 LAMP, W/ CLEAR ALUM. LENSES
33	PRESCLITE	ET4-ET4-PRS12	2-250W MH	277	RECESSED	ALUMINUM, 2 LAMP, W/ CLEAR ALUM. LENSES
34	ALCO	ET4-ET4-PRS12	2-250W MH	277	RECESSED	ALUMINUM, 2 LAMP, W/ CLEAR ALUM. LENSES
35	COLUMBIA	ET4-ET4-PRS12	2-250W MH	277	RECESSED	ALUMINUM, 2 LAMP, W/ CLEAR ALUM. LENSES
36	COLUMBIA	ET4-ET4-PRS12	2-250W MH	277	RECESSED	ALUMINUM, 2 LAMP, W/ CLEAR ALUM. LENSES
37	NOT USED					
38	KIM	1A-ET4-PRS12	1-250W MH	277	POLE	TYPE 1 DISTRIBUTION 12 FT. POLE W/ 2 FT. BASE
39	NOT USED					
40	KURT VERSEN	ET4-ET4-PRS12	2-250W MH	277	RECESSED	ALUMINUM, 2 LAMP, W/ CLEAR ALUM. LENSES
41	PRESCLITE	ET4-ET4-PRS12	2-250W MH	277	RECESSED	ALUMINUM, 2 LAMP, W/ CLEAR ALUM. LENSES
42	HAL	ET4-ET4-PRS12	2-250W MH	277	RECESSED	ALUMINUM, 2 LAMP, W/ CLEAR ALUM. LENSES
43	ALCO	ET4-ET4-PRS12	2-250W MH	277	RECESSED	ALUMINUM, 2 LAMP, W/ CLEAR ALUM. LENSES
44	ALCO	ET4-ET4-PRS12	2-250W MH	277	RECESSED	ALUMINUM, 2 LAMP, W/ CLEAR ALUM. LENSES
45	ALCO	ET4-ET4-PRS12	2-250W MH	277	RECESSED	ALUMINUM, 2 LAMP, W/ CLEAR ALUM. LENSES
46	PRESCLITE	ET4-ET4-PRS12	2-250W MH	277	RECESSED	ALUMINUM, 2 LAMP, W/ CLEAR ALUM. LENSES
47	NOT USED					
48	PRESCLITE	ET4-ET4-PRS12	2-250W MH	277	RECESSED	ALUMINUM, 2 LAMP, W/ CLEAR ALUM. LENSES
49	PRESCLITE	ET4-ET4-PRS12	2-250W MH	277	RECESSED	ALUMINUM, 2 LAMP, W/ CLEAR ALUM. LENSES
50	ADVENT	ET4-ET4-PRS12	2-250W MH	277	RECESSED	ALUMINUM, 2 LAMP, W/ CLEAR ALUM. LENSES
51	PRESCLITE	ET4-ET4-PRS12	2-250W MH	277	RECESSED	ALUMINUM, 2 LAMP, W/ CLEAR ALUM. LENSES
52	KIM	1A-ET4-PRS12	1-250W MH	277	BOLLARD	TYPE 1 DISTRIBUTION 12 FT. POLE W/ 2 FT. BASE
53	CELESTIAL	ET4-ET4-PRS12	2-250W MH	277	RECESSED	ALUMINUM, 2 LAMP, W/ CLEAR ALUM. LENSES
54	KIM	1A-ET4-PRS12	1-250W MH	277	STANCHION	TYPE 1 DISTRIBUTION 12 FT. POLE W/ 2 FT. BASE
55	KIM	1A-ET4-PRS12	1-250W MH	277	RECESSED	ALUMINUM, 2 LAMP, W/ CLEAR ALUM. LENSES

ELECTRICAL SHEET INDEX	
SHEET NUMBER	DESCRIPTION
E0.01	ELECTRICAL INDEX AND SCHEDULES
E0.02	ELECTRICAL LEGENDS
E0.03	ELECTRICAL EQUIPMENT CONNECTION SCHEDULES
E0.04	ELECTRICAL EQUIPMENT CONNECTION SCHEDULES
E0.05	ELECTRICAL SITE PLAN
E0.06	FIRST FLOOR PLAN - PART A- LIGHTING
E0.07	FIRST FLOOR PLAN - PART B- LIGHTING
E0.08	SECOND FLOOR PLAN - PART A- LIGHTING
E0.09	SECOND FLOOR PLAN - PART B- LIGHTING
E0.10	FIRST FLOOR PLAN - PART A- POWER
E0.11	FIRST FLOOR PLAN - PART B- POWER
E0.12	SECOND FLOOR PLAN - PART A- POWER
E0.13	SECOND FLOOR PLAN - PART B- POWER
E0.14	FIRST FLOOR PLAN - PART A- SYSTEMS
E0.15	FIRST FLOOR PLAN - PART B- SYSTEMS
E0.16	SECOND FLOOR PLAN - PART A- SYSTEMS
E0.17	SECOND FLOOR PLAN - PART B- SYSTEMS
E0.18	ROOF PLAN - PART A - ELECTRICAL
E0.19	ROOF PLAN - PART B - ELECTRICAL
E0.20	LARGE SCALE ELECTRICAL
E0.21	ELECTRICAL POWER DISTRIBUTION PDSB
E0.22	ELECTRICAL POWER DISTRIBUTION NORMAL ONE LINE DIAGRAM
E0.23	ELECTRICAL POWER DISTRIBUTION ESSENTIAL ONE LINE DIAGRAM
E0.24	ELECTRICAL POWER DISTRIBUTION ESSENTIAL ONE LINE DIAGRAM
E0.25	ELECTRICAL DETAILS
E0.26	ELECTRICAL PANELBOARD SCHEDULES - NORMAL SYSTEM
E0.27	ELECTRICAL PANELBOARD SCHEDULES - ESSENTIAL SYSTEM
E0.28	ELECTRICAL PANELBOARD SCHEDULES - ESSENTIAL SYSTEM

CONFORMS TO: GOVERNING ELECTRICAL CODE IS THE 1996 NATIONAL ELECTRICAL CODE WITH THE 2000 AMENDMENTS.

HVAC FIRE ALARM SHUTDOWN SCHEDULE		
NO.	AREA SHUT	FIRE ALARM CODE
1	2ND FLOOR ADMIN/RECEPTION	2A09
2	2ND FLOOR WAITING	1A
3	2ND FLOOR WAITING	1B
4	PATIENT ROOMS	2B0C
5	OPERATING ROOMS/SUPPORT	1C
6	2ND FLOOR WAITING (BUSINESS OCCUPANCY)	2A

DISCRETELY LOCATED WITHIN DISCRETE FIRE ALARM ZONES SHALL BE INSTALLED TO THE CORRESPONDING ROOM TYPE NAME AND ASSOCIATED DAMPER UPON DETECTION OF ALARM ACTIVATION.

FOR SYSTEM RESTRAINT OF EQUIPMENT SHOWN ON THIS SHEET, REFER TO SHEET E0.01 FOR THE LOCATION OF DISCRETE DETAILS INCLUDED IN THE CONSTRUCTION DOCUMENTS.

ALL LAMPS SHALL HAVE SH-10 OR BETTER UNLESS OTHERWISE NOTED
 TYPE 1A AND 1B FIXTURES SHALL BE LAMPED WITH CHROMA 85 OR EQUAL LAMPS.
 SEE LAMP PLANS FOR SPECIFICATIONS OF LAMP TYPES.
 COMPACT FLUORESCENT FIXTURES SHALL BE EQUIPPED WITH SHV BALLASTS, END OF LAMP BALLAST PROTECTOR.
 PAINT OR FINISH SHALL BE SELECTED AND APPROVED BY ARCHITECT.
 REFER TO ARCHITECTURAL REFLECTED CEILING PLANS FOR EXACT LOCATIONS.
 REFER TO ARCHITECTURAL REFLECTED CEILING PLANS AND DETAILS FOR EXACT TYPE OF COMPACT FLUORESCENT FIXTURES REQUIRED FOR CODE.
 ONLY TYPE 1A AND 1B FIXTURES CONNECTED TO A LIFE SAFETY BRANCH CIRCUIT FOR EMERGENCY LIGHTING SHALL BE PROVIDED WITH QUARTZ RESTRIC.

38	KIM	1A-ET4-PRS12	1-250W MH	277	POLE	TYPE 1 DISTRIBUTION 12 FT. POLE W/ 2 FT. BASE
----	-----	--------------	-----------	-----	------	---

The concrete base for light pole fixture #38 shall be provided with _____ vert. reinforcing bars & #3 ties @ 12" and extend _____ feet below grade.

- A. 6-#6, 5'-0"
- B. 6-#6, 6'-0"
- C. 7-#6, 5'-0"
- D. 7-#6, 6'-0"

Now that you know the height of the Light Pole and you are on the referred sheet, you can find the response

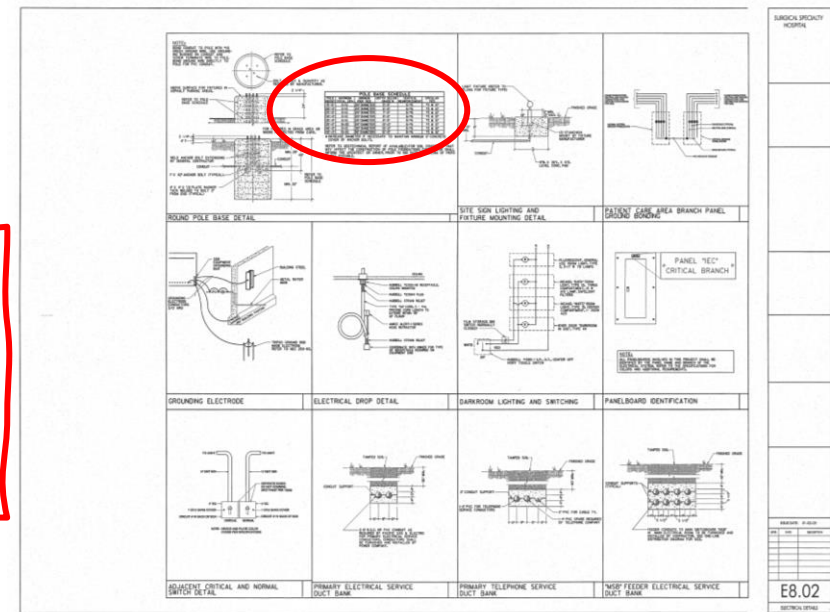

POLE BASE SCHEDULE					
POLE HEIGHT	MAXIMUM TOTAL EPA	MINIMUM PIER SIZE	DEPTH BELOW GRADE *	VERTICAL REINFORCEMENT	CIRCULAR TIES
15'-0"	0-10	20" DIAMETER	5'-0"	6-#6	#3 @ 12"
20'-0"	0-10	20" DIAMETER	6'-0"	6-#6	#3 @ 12"
25'-0"	0-10	20" DIAMETER	7'-0"	6-#6	#3 @ 12"
30'-0"	0-10	20" DIAMETER	8'-0"	6-#6	#3 @ 12"
35'-0"	0-10	24" DIAMETER	8'-0"	8-#6	#3 @ 12"
35'-0"	10-20	24" DIAMETER	10'-0"	8-#6	#3 @ 12"
40'-0"	0-10	30" DIAMETER	10'-0"	8-#6	#3 @ 16"
40'-0"	10-20	30" DIAMETER	12'-0"	8-#6	#3 @ 16"

* INCREASE DIAMETER IF NECESSARY TO MAINTAIN MINIMUM 6" CONCRETE COVER OF ANCHOR BOLTS.



Homework

Homework #1

The natural gas range/convection blower is served by which electrical panel and CKT?

- A. LN2B2-10
- B. LN2B2-7
- C. LEQ2A1-11
- D. LN2B2-14

Homework #2

The factory wired controller for RTU-5 is connected to what circuit?

- A. DHEQB1-7,8
- B. LEOQB1-21,8
- C. DHEQB1-7
- D. DHEQB1-8



Resolution

Homework #1

The natural gas range/convection blower is served by which electrical panel and CKT?

- A. LN2B2-10
- B. LN2B2-7
- C. LEQ2A1-11
- D. LN2B2-14

Homework #2

The factory wired controller for RTU-5 is connected to what circuit?

- A. DHEQB1-7,8
- B. LEOQB1-21,8
- C. DHEQB1-7
- D. DHEQB1-8



The natural gas range/convection blower is served by which electrical panel and CKT?

- A. LN2B2-10
- B. LN2B2-7
- C. LEQ2A1-11
- D. LN2B2-14



Look in the Electrical drawings for an enlarged plan or the kitchen area

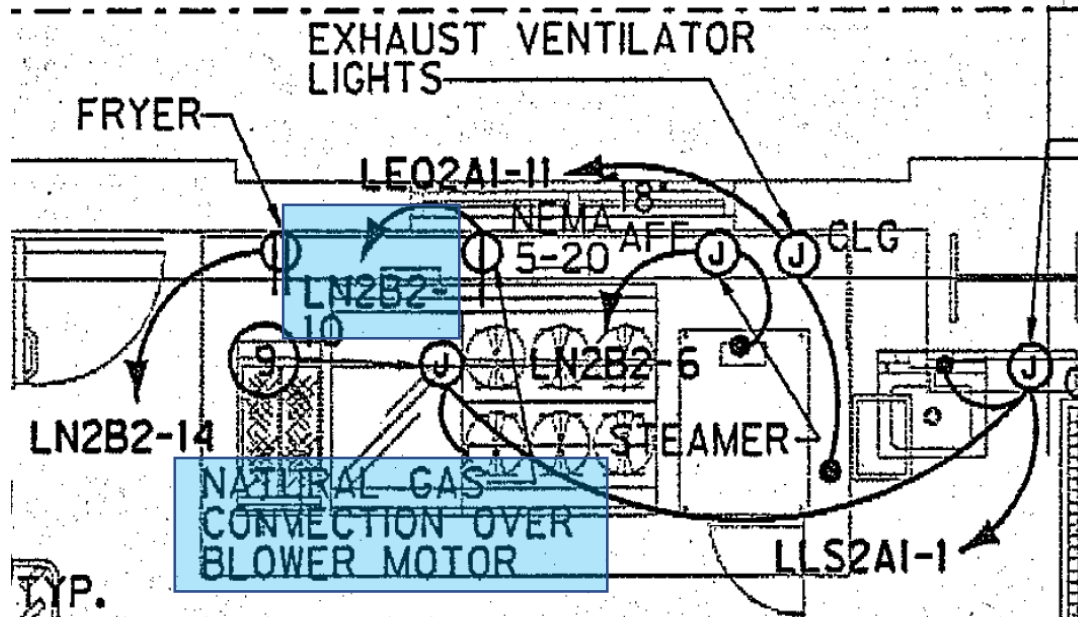
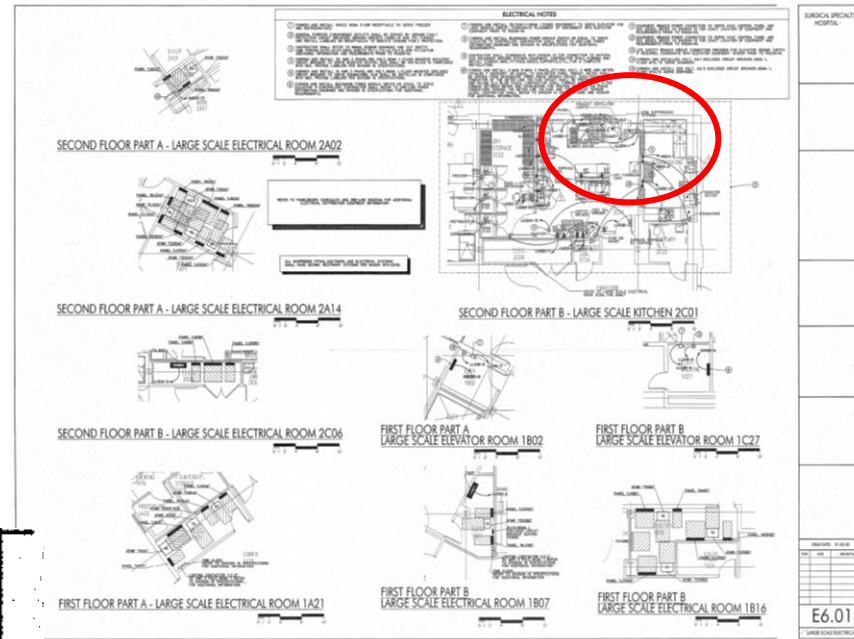

The factory wired controller for RTU-5 is connected to what circuit?

- A. DHEQB1-7,8
- B. LEOQB1-21,8
- C. DHEQB1-7
- D. DHEQB1-8

On E0.04, look at the Roof Equipment schedule

DIVISION 15 EQUIPMENT LEGEND - ROOF											
EQUIPMENT ID	EQUIPMENT TYPE	LOCATION	VOLTAGE/PHASE	AMPERAGE	WATTS	HP	BRANCH	CONNECTION TYPE	WIRE SIZE	CATEGORY	REMARKS
EF-1	EXHAUST FAN	ROOF PART A	120/1			1/8	EQUIPMENT	DIRECT CONNECTION	2#12,1#12G	MOTOR	DISCONNECT PROVIDED IN UNIT
EF-2	EXHAUST FAN	ROOF PART A	120/1			1/3	EQUIPMENT	DIRECT CONNECTION	2#12,1#12G	MOTOR	DISCONNECT PROVIDED IN UNIT
EF-3	EXHAUST FAN	ROOF PART A	120/1			1/2	EQUIPMENT	DIRECT CONNECTION	2#12,1#12G	MOTOR	DISCONNECT PROVIDED IN UNIT
RTU-1	SUPPLY FAN	ROOF PART A	480/3			30	EQUIPMENT	SINGLE POINT - CONTROL PANEL	3#8,1#10G	HVAC	CONTROL PANEL, VFD, AND LIGHTS FURNISHED WITH UNIT
RTU-1	RETURN FAN	ROOF PART A	480/3			7.5	EQUIPMENT	SINGLE POINT - CONTROL PANEL	3#12,1#12G	HVAC	CONTROL PANEL, VFD, AND LIGHTS FURNISHED WITH UNIT
RTU-2	SUPPLY FAN	ROOF PART A	480/3			20	EQUIPMENT	SINGLE POINT - CONTROL PANEL	3#10,1#12G	HVAC	CONTROL PANEL, VFD, AND LIGHTS FURNISHED WITH UNIT
RTU-2	RETURN FAN	ROOF PART A	480/3			5	EQUIPMENT	SINGLE POINT - CONTROL PANEL	3#12,1#12G	HVAC	CONTROL PANEL, VFD, AND LIGHTS FURNISHED WITH UNIT
EF-4	EXHAUST FAN	ROOF PART A	120/1			1/2	EQUIPMENT	DIRECT CONNECTION	2#12,1#12G	MOTOR	DISCONNECT PROVIDED IN UNIT
EF-5	EXHAUST FAN	ROOF PART A	120/1			1/2	EQUIPMENT	DIRECT CONNECTION	2#12,1#12G	MOTOR	DISCONNECT PROVIDED IN UNIT
RTU-3	SUPPLY FAN	ROOF PART B	480/3			30	EQUIPMENT	SINGLE POINT - CONTROL PANEL	3#8,1#10G	HVAC	CONTROL PANEL, VFD, AND LIGHTS FURNISHED WITH UNIT
RTU-3	RETURN FAN	ROOF PART B	480/3			7.5	EQUIPMENT	SINGLE POINT - CONTROL PANEL	3#12,1#12G	HVAC	CONTROL PANEL, VFD, AND LIGHTS FURNISHED WITH UNIT
RTU-4	SUPPLY FAN	ROOF PART B	480/3			30	EQUIPMENT	SINGLE POINT - CONTROL PANEL	3#8,1#10G	HVAC	CONTROL PANEL, VFD, AND LIGHTS FURNISHED WITH UNIT
RTU-4	RETURN FAN	ROOF PART B	480/3			7.5	EQUIPMENT	SINGLE POINT - CONTROL PANEL	3#12,1#12G	HVAC	CONTROL PANEL, VFD, AND LIGHTS FURNISHED WITH UNIT
EF-6	EXHAUST FAN	ROOF PART B	480/3			1	EQUIPMENT	DIRECT CONNECTION	3#12,1#12G	MOTOR	DISCONNECT PROVIDED WITH UNIT FVNR COMB. STARTER IN MCC
EF-7	EXHAUST FAN	ROOF PART B	120/1			1/3	EQUIPMENT	DIRECT CONNECTION	2#12,1#12G	MOTOR	DISCONNECT PROVIDED IN UNIT
EF-8	EXHAUST FAN	ROOF PART B	480/3			1	EQUIPMENT	DIRECT CONNECTION	3#12,1#12G	MOTOR	DISCONNECT PROVIDED WITH UNIT FVNR COMB. STARTER IN MCC
EF-9	EXHAUST FAN	ROOF PART B	120/1			1/4	EQUIPMENT	DIRECT CONNECTION	2#12,1#12G	MOTOR	DISCONNECT PROVIDED IN UNIT
EF-10	EXHAUST FAN	ROOF PART B	480/3			2	EQUIPMENT	DIRECT CONNECTION	3#12,1#12G	MOTOR	DISCONNECT PROVIDED WITH UNIT FVNR COMB. STARTER IN MCC
EF-11	EXHAUST FAN	ROOF PART B	120/1			3/4	EQUIPMENT	DIRECT CONNECTION	2#12,1#12G	MOTOR	DISCONNECT PROVIDED WITH UNIT
EF-12	EXHAUST FAN	ROOF PART B	480/3			1	EQUIPMENT	DIRECT CONNECTION	3#12,1#12G	MOTOR	DISCONNECT PROVIDED WITH UNIT FVNR COMB. STARTER IN MCC
EF-13	EXHAUST FAN	ROOF PART B	120/1			1/4	EQUIPMENT	30/3/NEMA 3R DISCONNECT AT UNIT	2#12,1#12G	MOTOR	
MAU-1	MAKE-UP AIR UNIT	ROOF PART B	480/3			1/4	EQUIPMENT	30/3/NEMA 3R DISCONNECT AT UNIT	3#12,1#12G	HVAC	FVNR COMBINATION STARTER IN MCC
RTU-5	SUPPLY FAN	ROOF PART B	480/3			75	EQUIPMENT	SINGLE POINT - CONTROL PANEL	3#1,1#8G	HVAC	CONTROL PANEL, VFD, AND LIGHTS FURNISHED WITH UNIT
RTU-5	RETURN FAN	ROOF PART B	480/3			25	EQUIPMENT	SINGLE POINT - CONTROL PANEL	3#8,1#10G	HVAC	CONTROL PANEL, VFD, AND LIGHTS FURNISHED WITH UNIT
EF-14	EXHAUST FAN	ROOF PART B	120/1			1/6	EQUIPMENT	DIRECT CONNECTION	2#12,1#12G	MOTOR	DISCONNECT PROVIDED IN UNIT
SF-1	EXHAUST FAN	ROOF PART B	480/3			3	EQUIPMENT	30/3/NEMA 3R DISCONNECT AT UNIT	2#12,1#12G	MOTOR	FVNR COMBINATION STARTER IN MCC



The factory wired controller for RTU-5 is connected to what circuit?

- A. DHEQB1-7,8
- B. LEOQB1-21,8
- C. DHEQB1-7
- D. DHEQB1-8

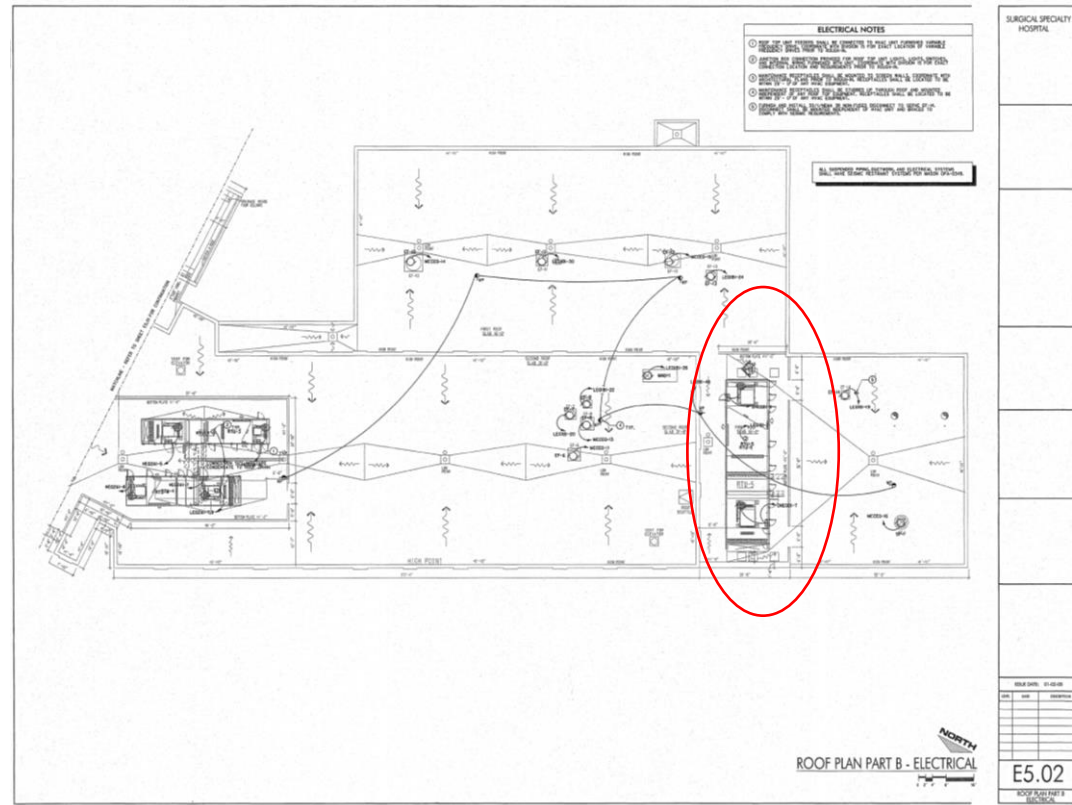

In the Electrical Roof Plan, look for the RTU-5. There are 2 circuit connected. Let's verify into the schedule

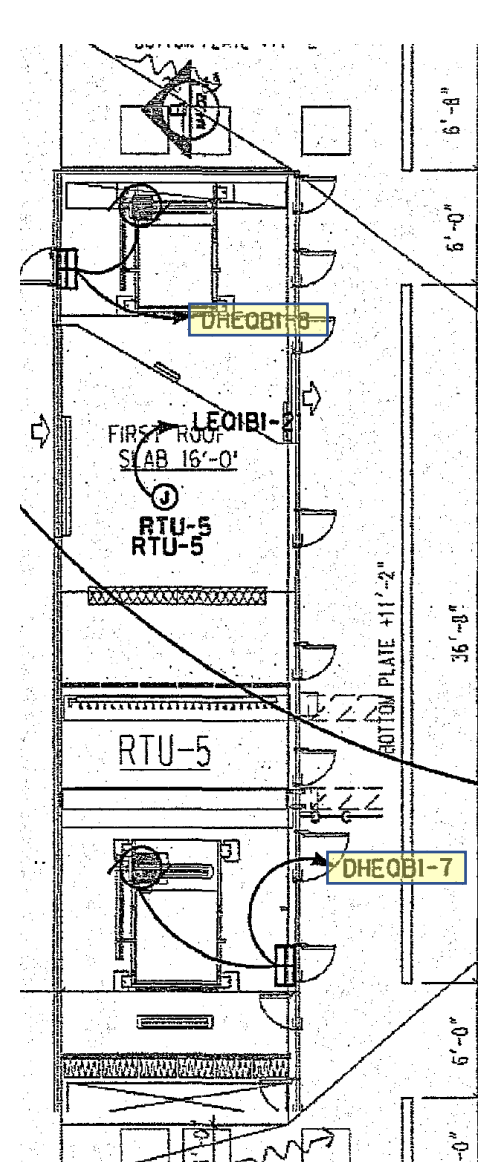

The factory wired controller for RTU-5 is connected to what circuit?

- A. DHEQB1-7,8
- B. LEOQB1-21,8
- C. DHEQB1-7
- D. DHEQB1-8



PANEL: DHEQB1		DC DEVICE TYPE: Breaker		ENCLOSURE: NEMA 1		MAINS(A): MLO		BUS RATING(A): 800	
LOCATION: ELECTRIC ROOM 1C30		DEVICE FAMILY: Plug In		MOUNTING: Surface		WIRING: 3-Phase 4-Wire		WITHSTAND(A): 65000	
FED FROM: ATS EQ LOAD				VOLTAGE: 480/277				FAULT CURRENT(A): 41203	
CUBICLE NO	DESCRIPTION	CONNECTED KVA	DEMAND KVA	DESIGN KVA	DESIGN AMPS	DC DEVICE TYPE	SIZE	P	NOTES
1	MCCE0 BUS	135.69	133.82	139.43	167.70	CB	300	3	REFER TO ONE-LINE
2	TED1B2 PRI	1.24	1.24	1.24	1.49	CB	30	3	REFER TO ONE-LINE
3	HEQ2A1 BUS	171.14	171.14	171.14	205.85	CB	400	3	REFER TO ONE-LINE
4	STERIS STERILIZER	30.76	30.76	30.76	37.00	CB	50	3	3#8.1#10G
5	SPACE	0.00	0.00	0.00	0.00		250	3	
6	STERIS WASHER	10.81	10.81	10.81	13.00	CB	20	3	3#12.1#12G
7	RTU-5 SUPPLY	79.81	79.81	79.81	96.00	CB	125	3	3#1.1#6G
8	RTU-5 RETURN	28.27	28.27	28.27	34.00	CB	70	3	3#8.1#10G
9	SPACE	0.00	0.00	0.00	0.00		250	3	
10	ELEV 1 BUS	46.63	46.63	58.28	70.10	CB	100	3	REFER TO ONE-LINE
11	SPACE	0.00	0.00	0.00	0.00		250	3	
12	SPACE	0.00	0.00	0.00	0.00		250	3	
13	SPACE	0.00	0.00	0.00	0.00		250	3	
14	SPACE	0.00	0.00	0.00	0.00		250	3	
ALL CONNECTED		KVA	AMPS	* PHASE TOTALS		VA	AMPS	BUS TOTALS	
TOTAL CONNECTED		492.23	595.9	* A-N	162632.8		586.9	CONNECTED	492.23
TOTAL DEMAND		490.26	592.3	* B-N	165132.3		595.9	DEMAND	490.26
TOTAL DESIGN		500.58	604.7	* C-N	164479.7		593.5	DESIGN	500.58

And it is confirmed.



Fire Life Safety



Example #1



When referring to the wall type details contained on sheet A6.20 of the plans what is the appropriate design number for the fire stop system required at the deflection track of a 2-hour fire rated wall?

What do you need to look at? On A6.20, 2-hour wall detail. Then look for DESIGN NUMBER for Fire stop system

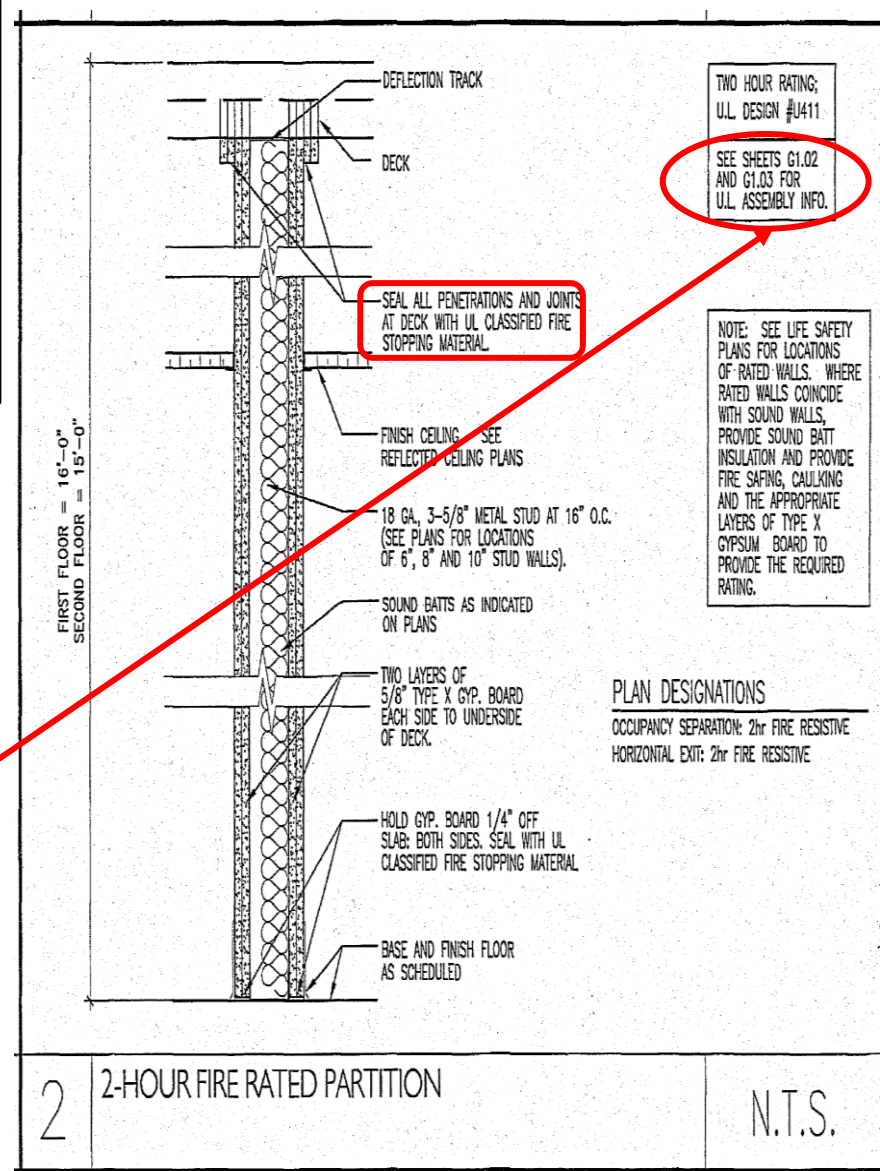

9 METAL STUD END-CHARGE TYPICAL AT ALL PARTITIONS	N.T.S.	6 2-HOUR GYPSUM BOARD SHY WALL	N.T.S.	3 INDICATED INTERNAL GITE PARTITION TO DECK	N.T.S.
8 METAL STUD MIDDLE-CHARGE TYPICAL AT ALL PARTITIONS	N.T.S.	5 NOT USED		2 1-HOUR FIRE RATED PARTITION	N.T.S.
7 HALF-HEIGHT WALL	N.T.S.	4 NOT USED		1 1-HOUR FIRE RATED PARTITION	N.T.S.

A6.20



When referring to the wall type details contained on sheet A6.20 of the plans what is the appropriate design number for the fire stop system required at the deflection track of a 2-hour fire rated wall?

- A. U411
- B. U438
- C. HW-D0001
- D. HW-D0002
- E. None of the above



Look G1.02, and G1.03 and find the assembly information for 2-hour rating at the deflection track

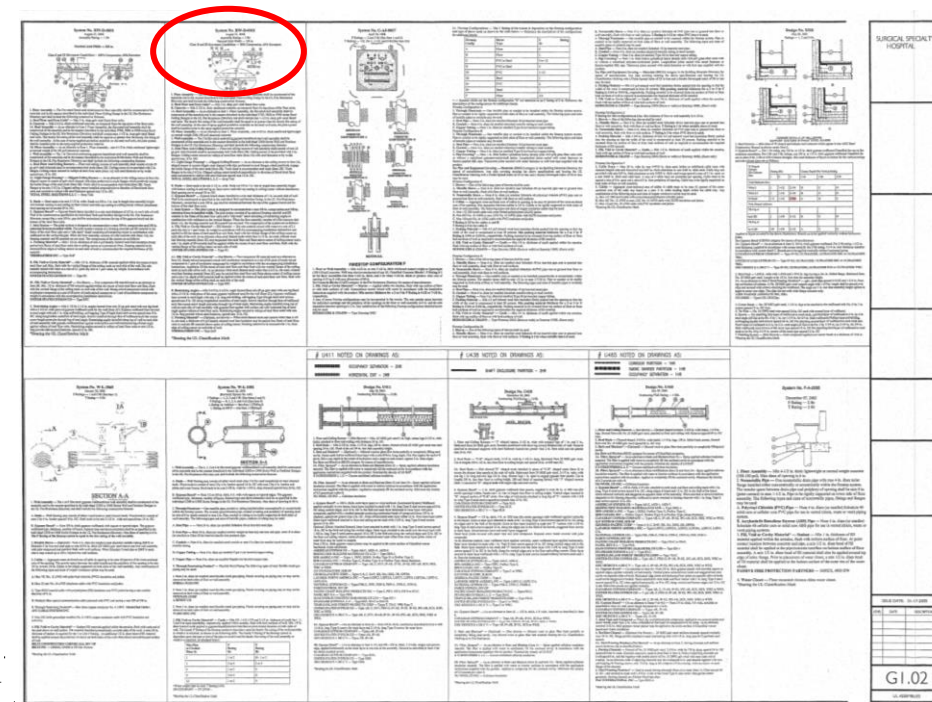

System No. HW-D-0002

August 21, 2002

Assembly Rating — 2 Hr

Nominal Joint Width — 5/8 in.

Class II and III Movement Capabilities — 30% Compression, 60% Extension

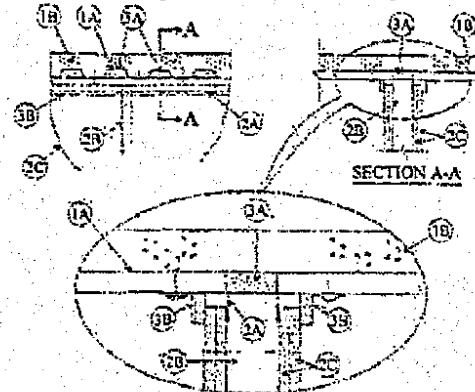

sembly — The fire-rated fluted steel deck/concrete floor assembly shall be constructed of the



Example #2



The California Fire Code requires that the aboveground fuel tanks be a minimum of 10' from the nearest building and 5' from the closest property line. What are the separation distances listed for the emergency generator fuel tank and do they comply with the above listed requirements?

The minimum dimension from nearest building and property line to the Generator could be found in the architectural site plan, or in the mechanical plan. You need to look for both to see where the actual information is located.

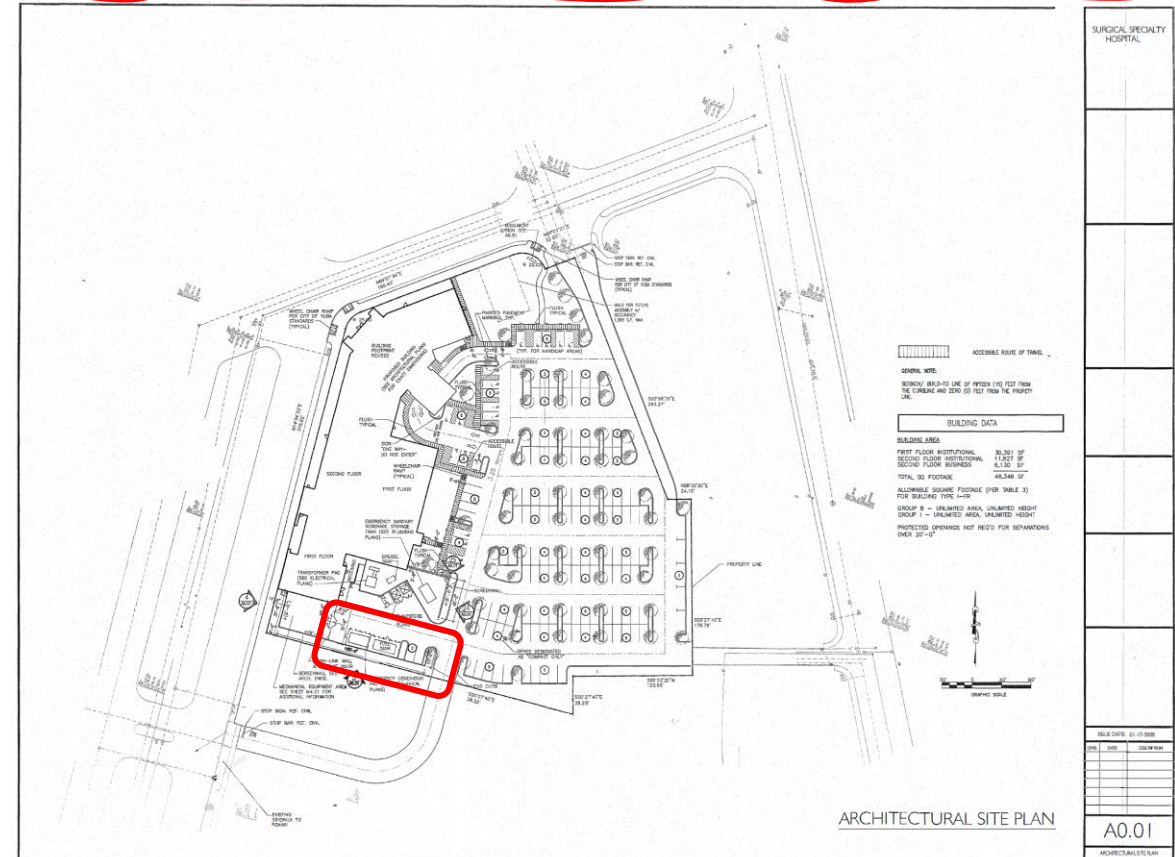
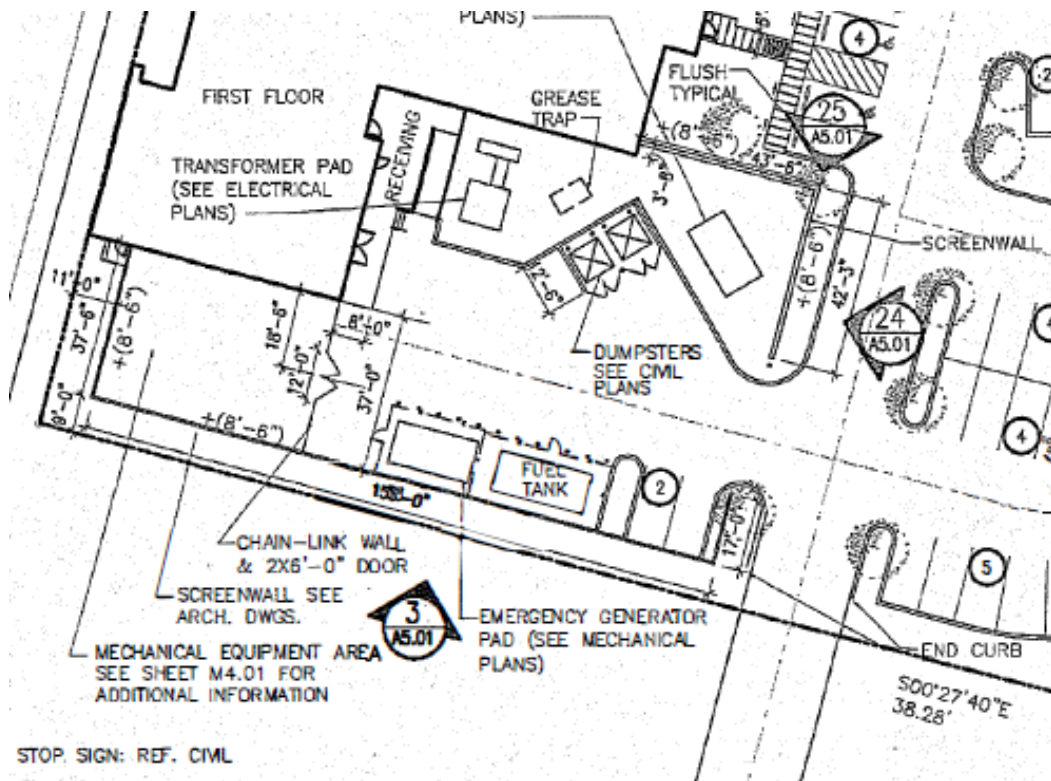

The California Fire Code requires that the aboveground fuel tanks be a minimum of 10' from the nearest building and 5' from the closest property line. What are the separation distances listed for the emergency generator fuel tank and do they comply with the above listed requirements?

In M4.01, Mechanical Room the information is clear

- A. Yes, the tank is 75' from the building and >6'-4" to the property line
- B. Yes, the tank is 75' from the building and 9' to the property line
- C. Yes, the tank is 37'-6" from the building and 9' to the property line
- D. No, the tank is 18'-6" from the building but only 4'-6" to the property line

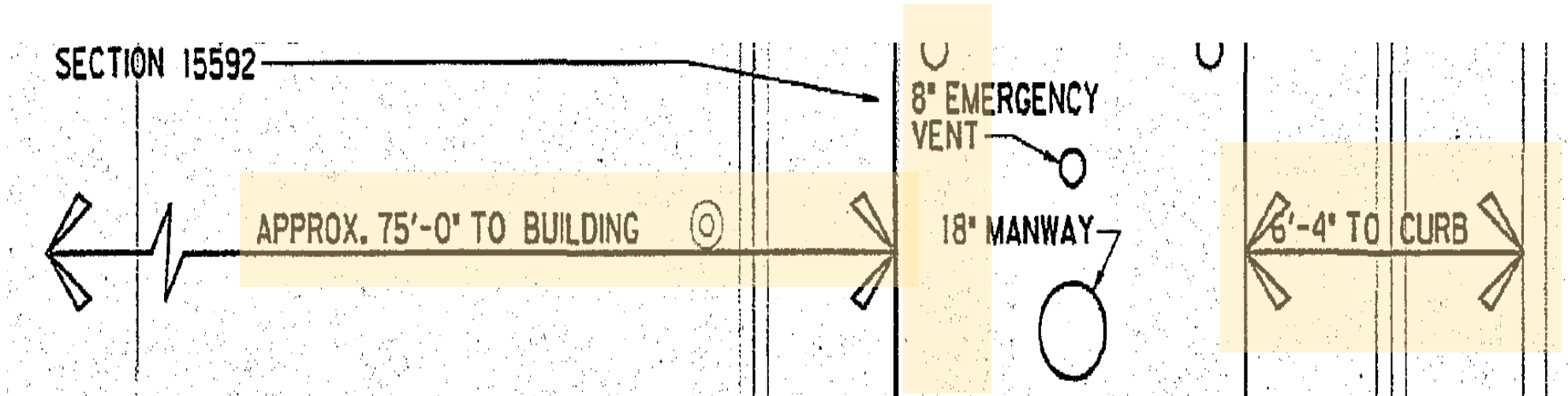

Example #3



What is the minimum thickness of the fire protection required for the two columns located at Grid Line E 12?

First step, which is the column size on Grid Line E-12? Look at Column Schedule...

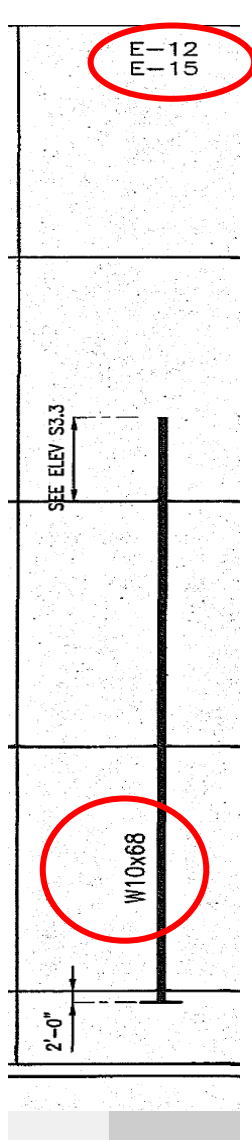

COLUMN SCHEDULE							
GRID	TYPE	SECTION	WEIGHT	DEPTH	FLANGE THICKNESS	FLANGE DIAMETER	WELD
E-12	W10	68	68	10	0.5	10	
E-15	W10	68	68	10	0.5	10	

BASE PLATE SCHEDULE							
GRID	TYPE	SECTION	WEIGHT	DEPTH	FLANGE THICKNESS	FLANGE DIAMETER	WELD
E-12	W10	68	68	10	0.5	10	
E-15	W10	68	68	10	0.5	10	

SURGICAL SPECIALTY HOSPITAL

DATE: 01-10-2010

NO. REV. DESCRIPTION

S5.1

SECTION SCHEDULE & DETAILS

What is the minimum thickness of the fire protection required for the two columns located at Grid Line E 12?

Then, look for the UL # for columns

The image displays a comprehensive architectural drawing set. Key sections include:

- CODE ANALYSIS:** Lists applicable codes such as California Building Code (CBC) and California Fire Code (CFC) for various occupancy types and fire ratings.
- GENERAL NOTES:** Contains detailed instructions regarding fire protection, structural requirements, and construction details. A red circle highlights a specific note related to fire protection for columns.
- NEIGHBORHOOD MAP:** Shows the project location within a city grid.
- MASTER DRAWING INDEX:** Provides a detailed index of all drawing sheets, including their titles and sheet numbers.
- ABBREVIATIONS:** Lists various abbreviations used throughout the drawing.
- MATERIAL DESIGNATIONS:** Defines symbols for different materials and finishes, such as brick, concrete, and wood.
- CONSULTANTS:** Lists the names of various engineering and architectural consultants.
- BUILDING DATA:** Provides key project information, including the project name, location, and dates.

Structural Frame (Columns)

3 Hour - UL DESIGN #X528

What is the minimum thickness of the fire protection required for the two columns located at Grid Line E 12?

- A. 1-1/2"
- B. 1-5/8"
- C. 1-7/8"
- D. 2-1/4"



You know the column size, and rating. Go to UL#X528 on G1.02...

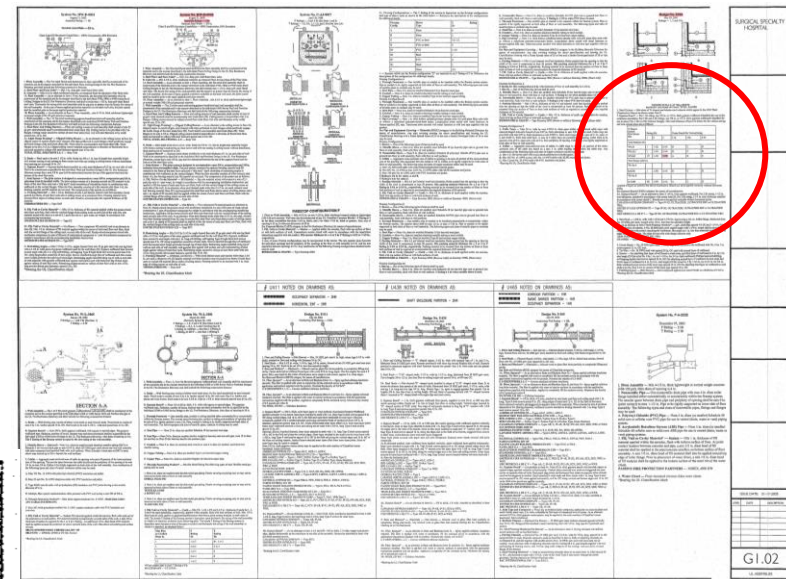

W Shaped Columns

W Shaped Column Min Column Size	Rating (Hr)			Corner Details For Various Rating		
	1	2	3	1 Hr	2 Hr	3 Hr
Total thickness (In.)						
W4x13	1	1-1/2	2-1/4	B	C	D
W6x15.5	1	1-1/2	2-1/4	B	C	D
W10x49	1/2	1-1/8	1-7/8	A	B	C
Tube Shaped columns						
TS 4 by 4						
by 0.188	1	1-5/8	2-1/2	B	C	D
TS 8 by 8						
by 0.250	5/8	1-5/8	2-1/2	A	C	D



Example #4



What type of emergency lighting is to be provided at the Ground Floor Part "B" Boiler Room?



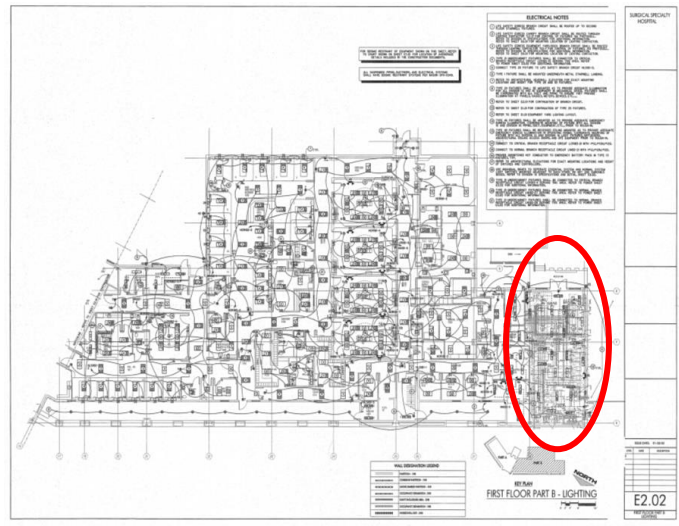
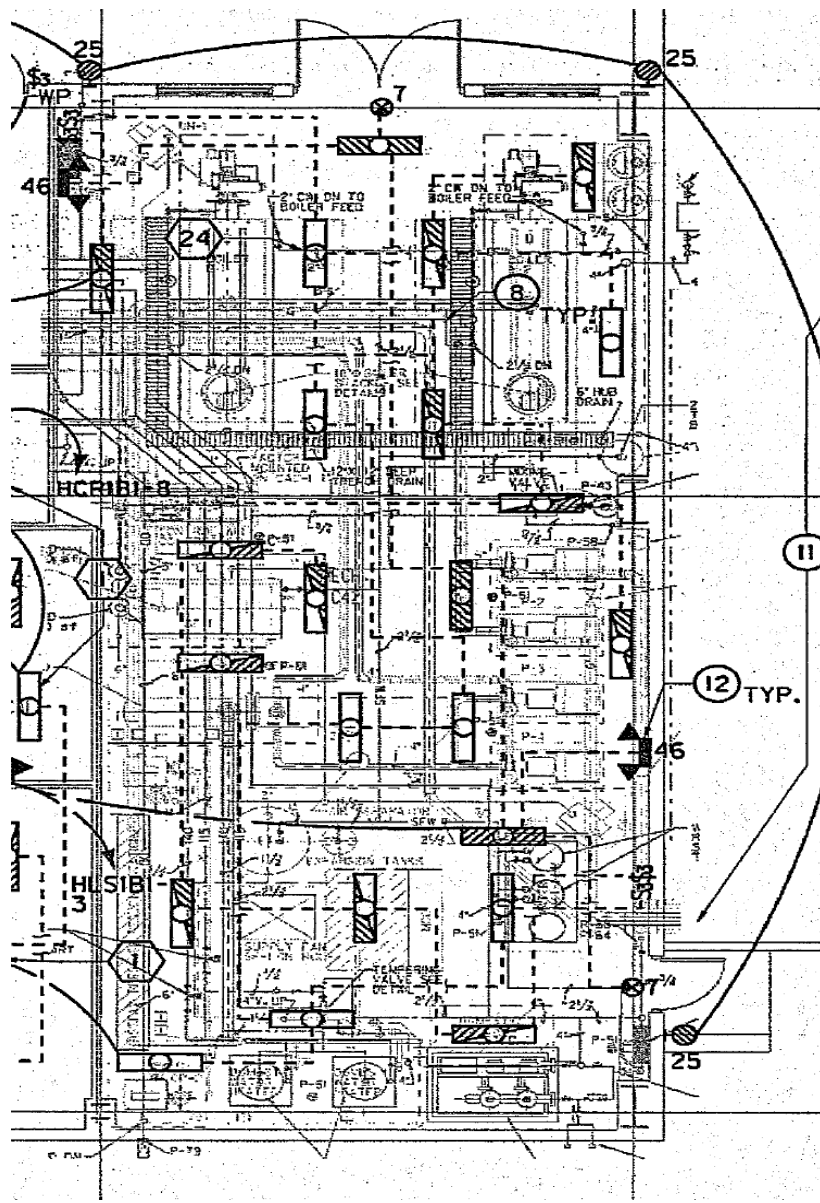









First of all, look the light fixture located in the Boiler Room



What type of emergency lighting is to be provided at the Ground Floor Part "B" Boiler Room?

Look for legend symbols for any critical and emergency light fixture and compare with the one in the Boiler Room



-  CRITICAL BRANCH SURFACE OR RECESSED FLRS. FIXTURE
-  LIFE-SAFETY BRANCH SURFACE OR RECESSED FLRS. FIXTURE
-  NORMAL BRANCH SURFACE OR RECESSED FIXTURE
-  CRITICAL BRANCH SURFACE OR RECESSED FIXTURE
-  LIFE-SAFETY BRANCH SURFACE OR RECESSED FIXTURE
-  FLUORESCENT FIXTURE
-  CRITICAL BRANCH SURFACE OR SUSPENDED FLRS. FIXTURE
-  LIFE-SAFETY BRANCH SURFACE OR SUSPENDED FLRS. FIXTURE
-  WALL BRACKET FIXTURE
-  LIFE-SAFETY BRANCH WALL BRACKET FIXTURE
-  EXIT LIGHTS
-  BATTERY POWERED EMERGENCY LIGHT

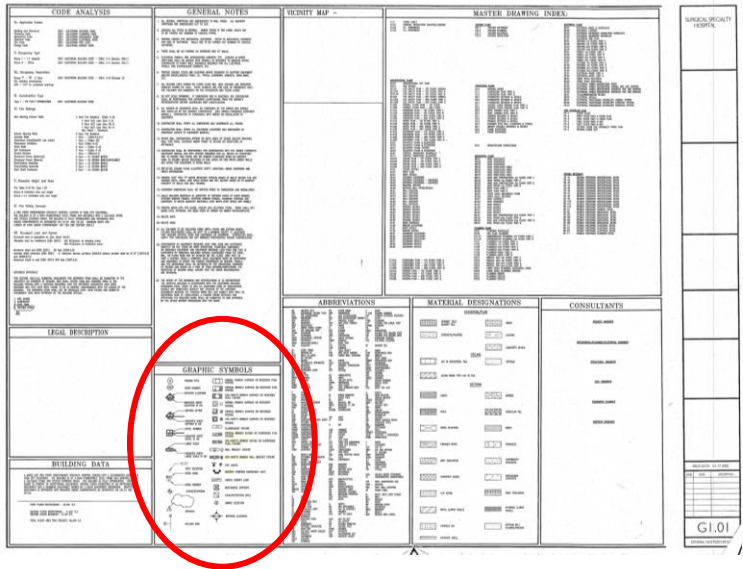

What type of emergency lighting is to be provided at the Ground Floor Part "B" Boiler Room?

- A. Life Safety Branch powered
- B. Critical Branch powered
- C. Battery powered
- D. All of the above
- E. Only A and C



	CRITICAL BRANCH SURFACE OR RECESSED FLRS. FIXTURE
	LIFE-SAFETY BRANCH SURFACE OR RECESSED FLRS. FIXTURE
	NORMAL BRANCH SURFACE OR RECESSED FIXTURE
	CRITICAL BRANCH SURFACE OR RECESSED FIXTURE
	LIFE-SAFETY BRANCH SURFACE OR RECESSED FIXTURE
	FLUORESCENT FIXTURE
	CRITICAL BRANCH SURFACE OR SUSPENDED FLRS. FIXTURE
	LIFE-SAFETY BRANCH SURFACE OR SUSPENDED FLRS. FIXTURE
	WALL BRACKET FIXTURE
	LIFE-SAFETY BRANCH WALL BRACKET FIXTURE
	EXIT LIGHTS
	BATTERY POWERED EMERGENCY LIGHT

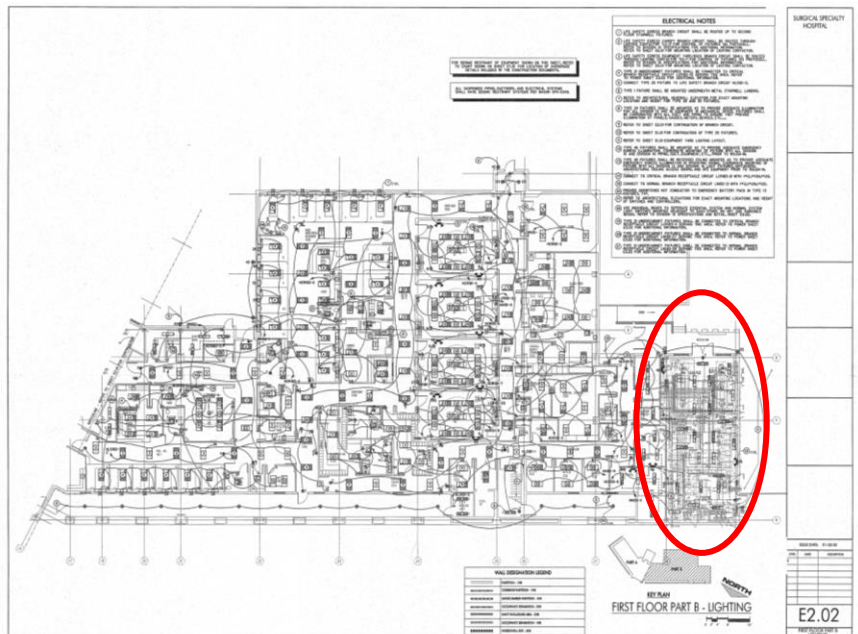

CODE ANALYSIS	GENERAL NOTES	IDENTITY MAP	MASTER DRAWING INDEX
LEGAL DESCRIPTION	ABBREVIATIONS	MATERIAL DESIGNATIONS	CONSULTANTS
BUILDING DATA	GRAPHIC SYMBOLS		

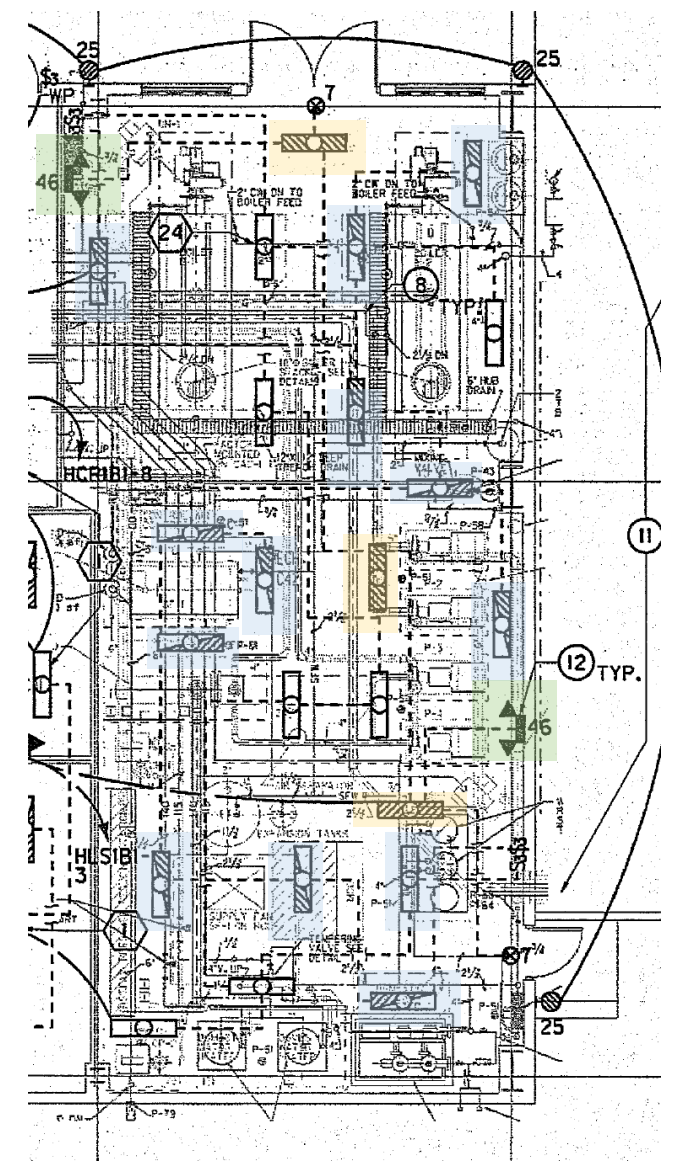

Example #5



What is the size of the riser supplying sprinklers on the 1st and 2nd floors?

Look the Riser Detail From the Sprinkler drawings

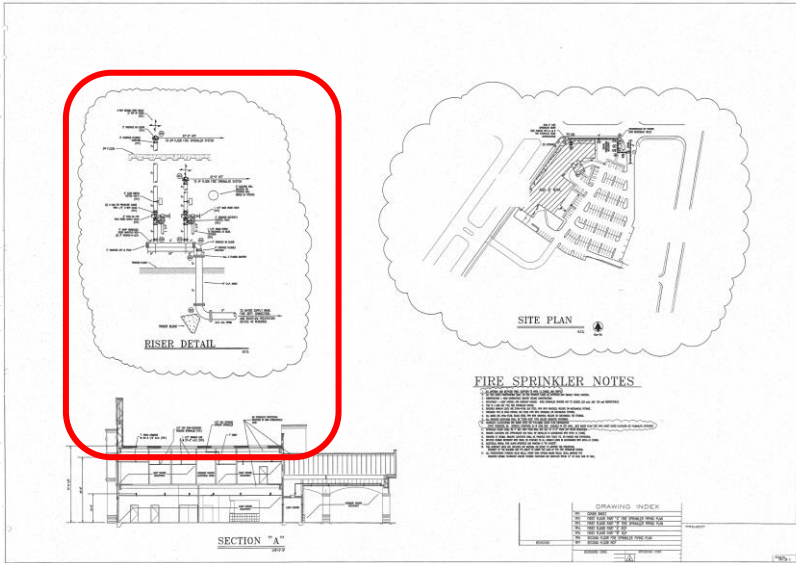
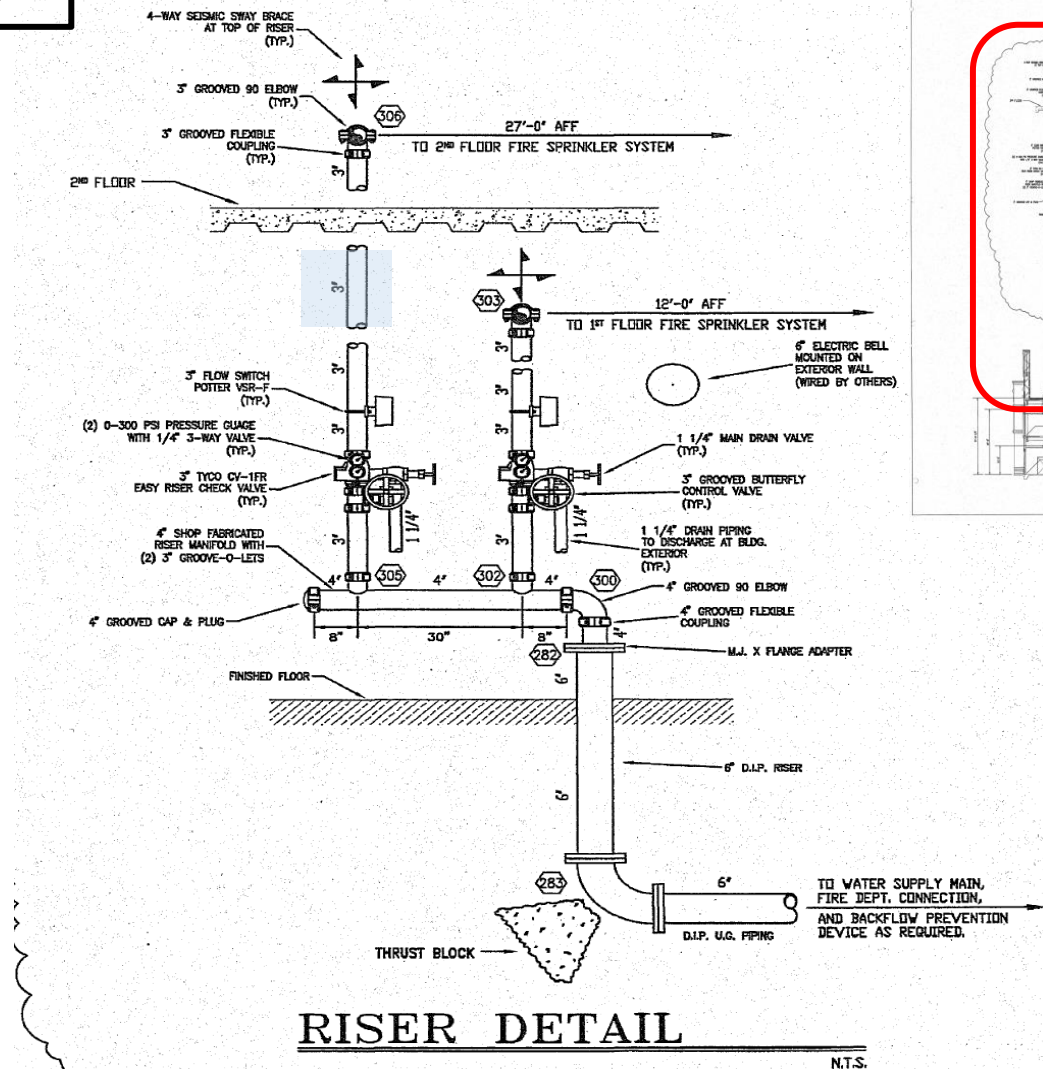

What is the size of the riser supplying sprinklers on the 1st and 2nd floors?

Plumbing Drawings also have a Sprinkler System Riser detail

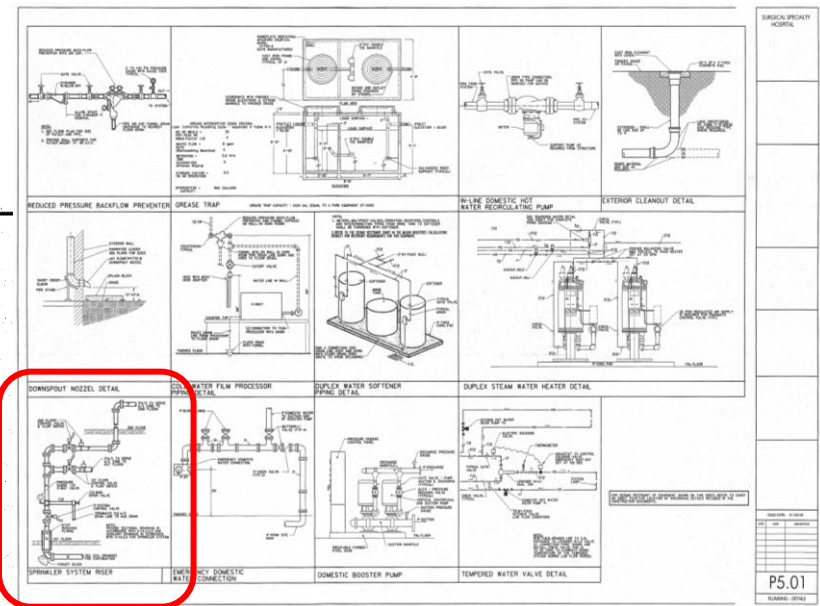
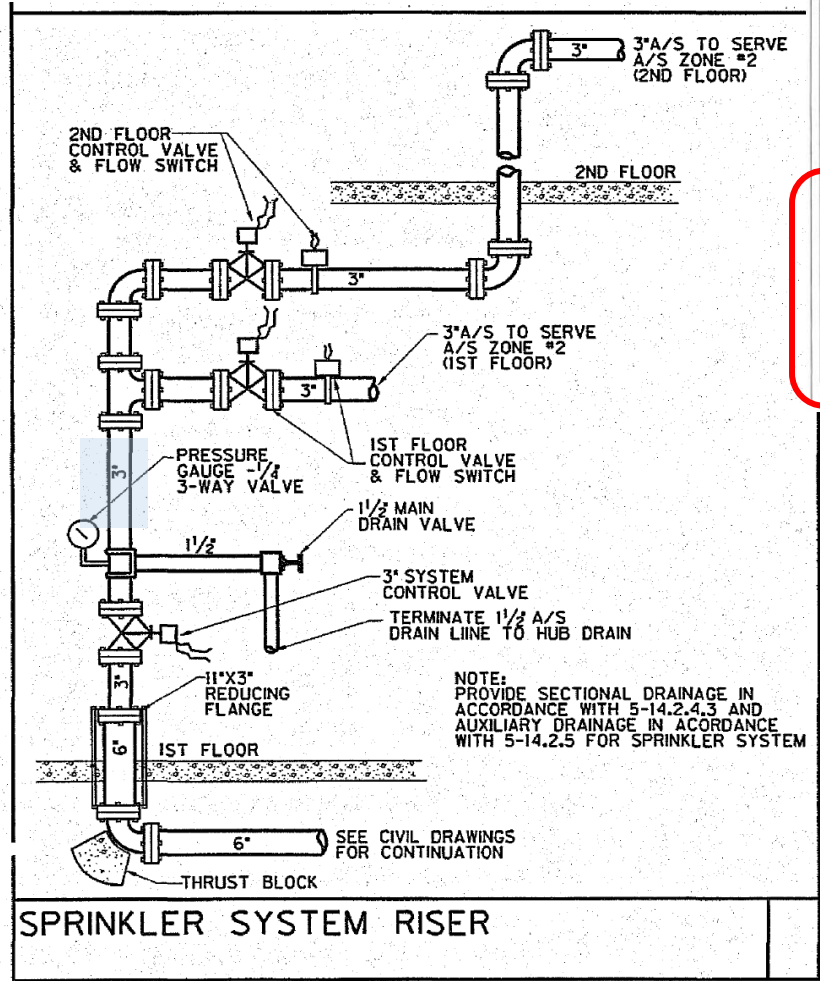

What is the size of the riser supplying sprinklers on the 1st and 2nd floors?

- A. 2½-inch
- B. 3-inch
- C. 4-inch
- D. 6-inch



Compare the two details

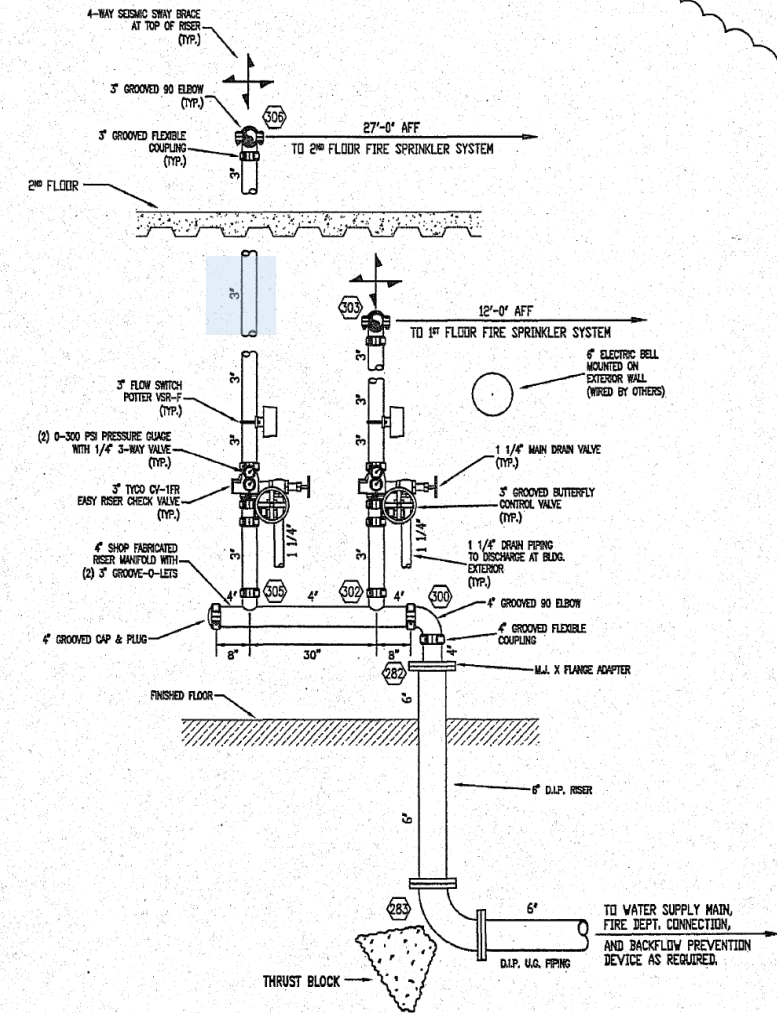
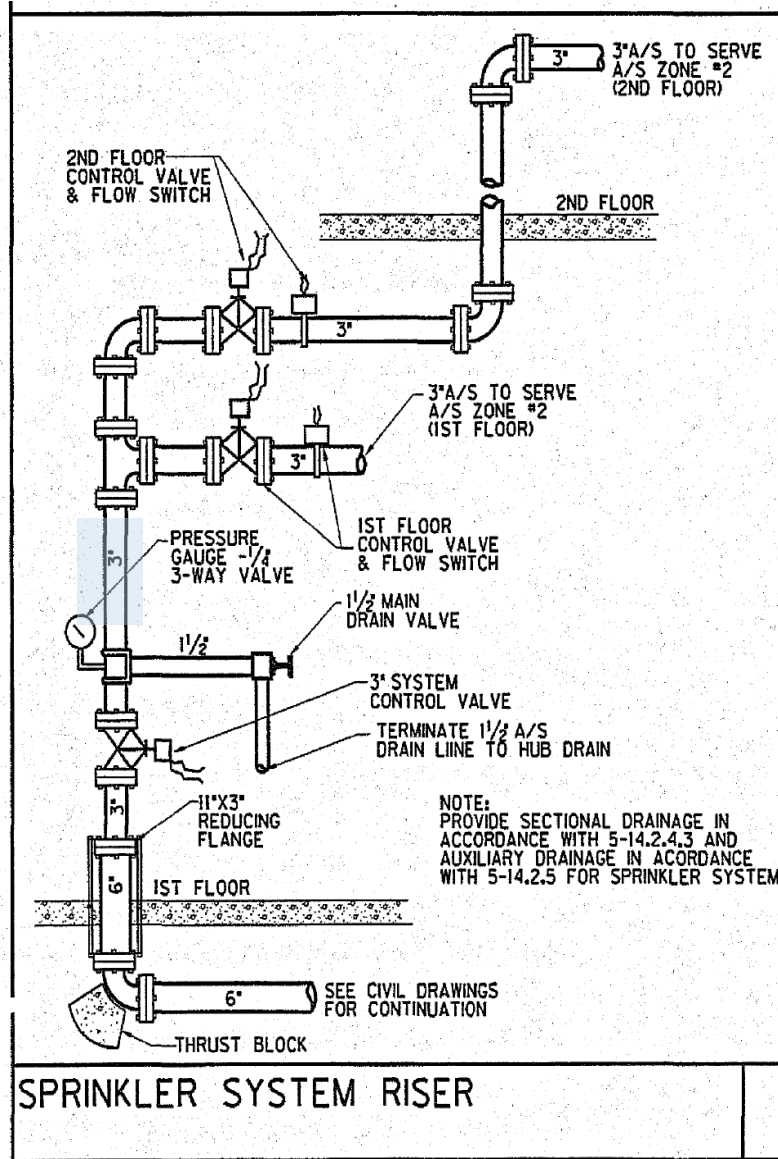

Homework

According to the plan how many exits have been Provided from the Ground Floor Part "A" 1A02 Lobby?

- A. One
- B. Two
- C. Three
- D. Four

According to the plan what is the clear width of the 2nd. floor stair landing in the direction of door swing?

- A. 44"
- B. 3'-10"
- C. 5'-9"
- D. None of the above



Resolution

Homework #1

According to the plan how many exits have been Provided from the Ground Floor Part "A" 1A02 Lobby?

- A. One
- B. Two
- C. Three
- D. Four

Homework #2

According to the plan what is the clear width of the 2nd. floor stair landing in the direction of door swing?

- A. 44"
- B. 3'-10"
- C. 5'-9"
- D. None of the above



According to the plan how many exits have been Provided from the Ground Floor Part “A” 1A02 Lobby?

- A. One
- B. Two
- C. Three
- D. Four

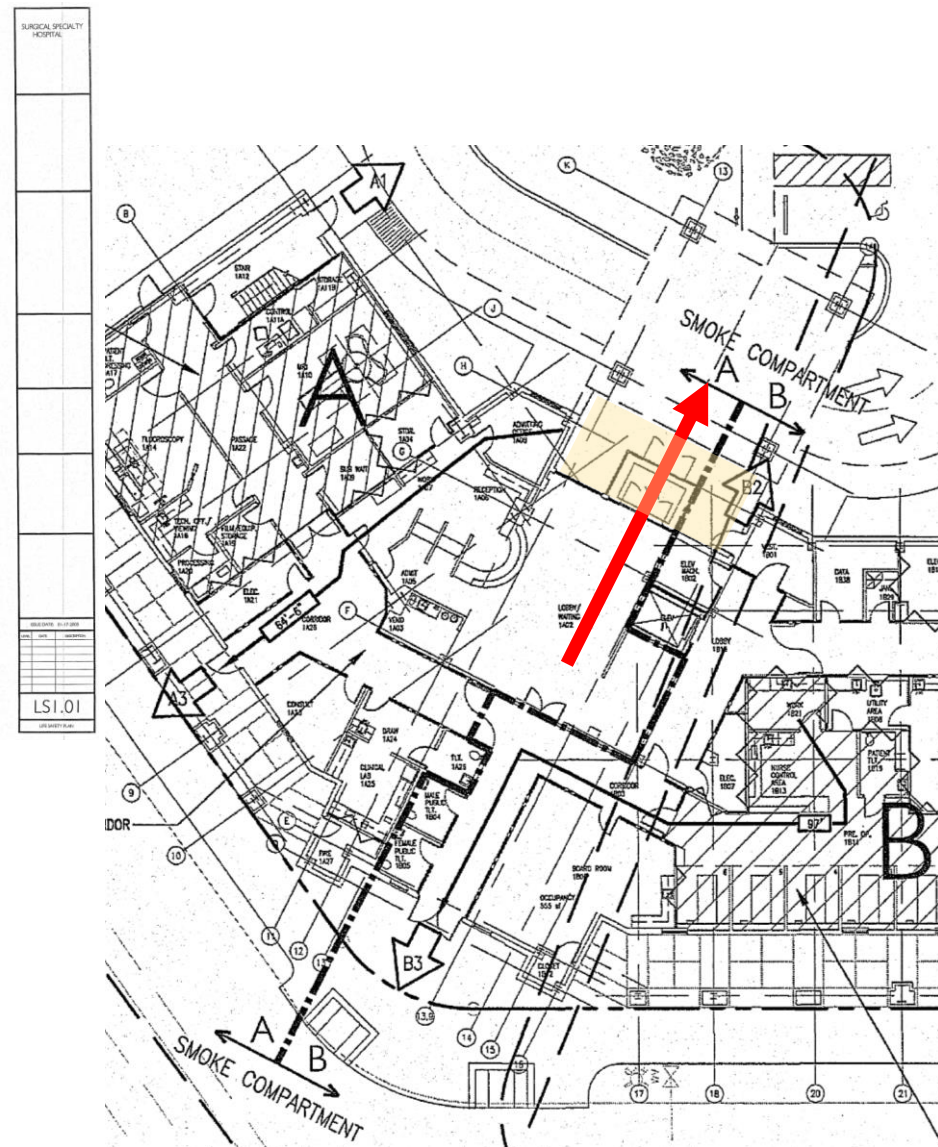
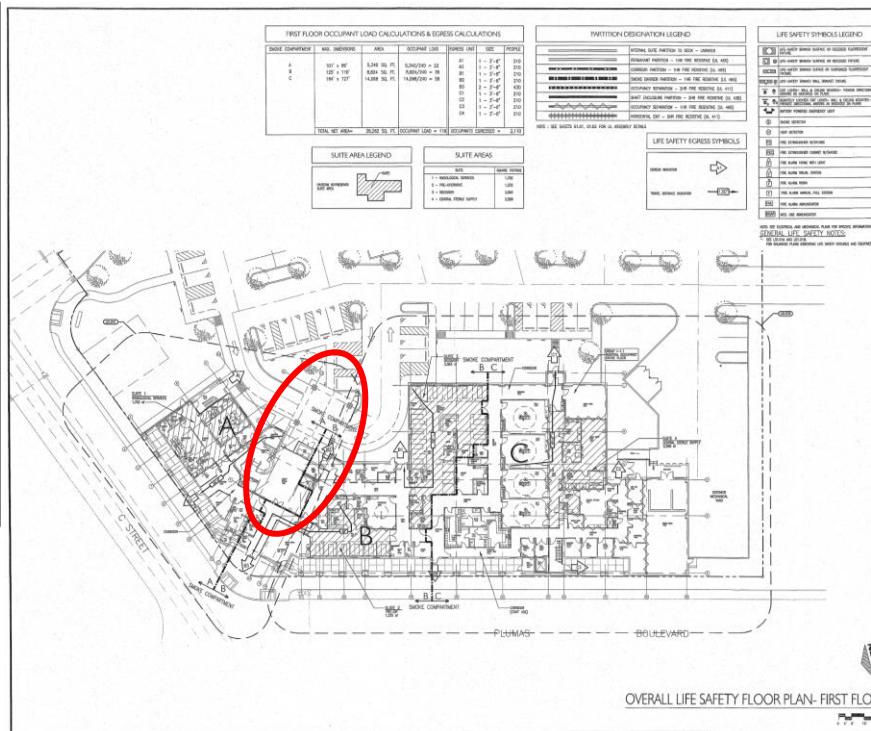

Look for the door swing...



According to the plan what is the clear width of the 2nd. floor stair landing in the direction of door swing?

- A. 44"
- B. 3'-10"
- C. 5'-9"
- D. None of the above



Look at the Stairs enlarged plans in A2.61

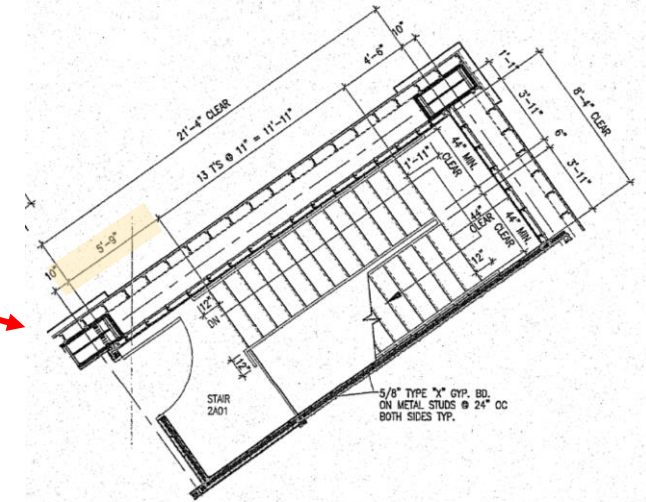
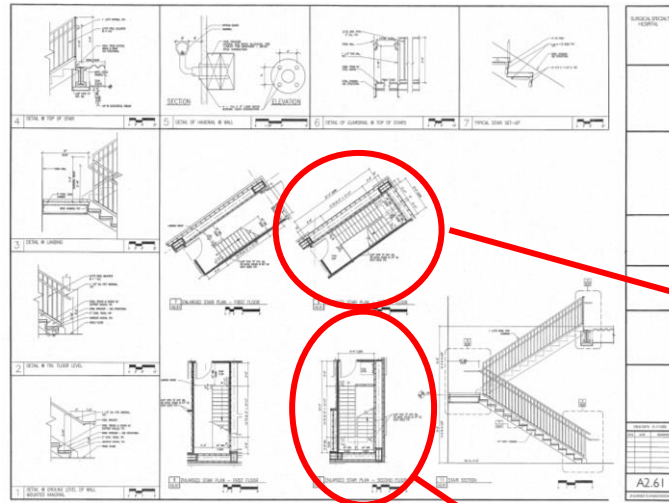

8 ENLARGED STAIR PLAN - SECOND FLOOR
A2.61

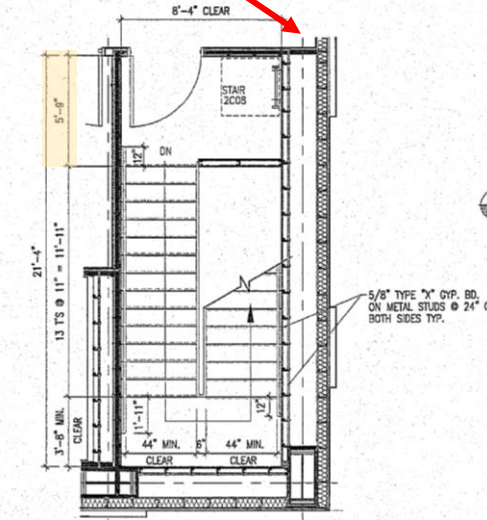

10 ENLARGED STAIR PLAN - SECOND FLOOR
A2.61



Do you have a question?

Email us at:

OSHPD.fddisu@oshpd.ca.gov

