



## **SUBJECT**

NPC-2 Seismic Bracing Upgrades

**PIN:** 32

**Effective:** 5/03/2001

**Revised:** 9/19/2011



## **BACKGROUND**

Health and Safety Code Section 130005 directs OSHPD to develop definitions of earthquake performance categories. These categories must include subgradations for hospital building equipment and nonstructural systems critical to providing basic services to hospital inpatients and the public after a disaster. Hospital buildings were required to meet the NPC-2 level of seismic bracing and anchorage by January 1, 2002. Two critical systems included in the NPC-2 performance level are fire alarm systems and emergency egress lighting systems.

Many fire alarm system and emergency communication system panels are relatively small, wall-mounted units. Nominal anchorage, typically provided for panel installation, can provide adequate lateral support for seismic loading. This document covers procedures for verifying the adequacy of the panel anchorage.

The methods outlined, and details described in this Policy Intent Notice (PIN) indicate acceptable methods for achieving compliance for NPC-2 emergency exiting lighting, and exit signage support. The purpose is to provide and specify methods and details that comply with SB 1953 NPC-2 emergency egress lighting, and exit sign requirements, that may be approved in either the office or the field. Other methods proposed by the design professional of record to solve a particular problem shall be reviewed by OSHPD, and may also be acceptable. The methods and details specified in this PIN to retrofit existing emergency egress lighting, and exiting signage fixtures are intended to be an interim and incremental solution towards full code compliance of these fixtures at a later date. The intent of this document is to provide for reliable vertical support for these fixtures only. Additional modifications to these fixtures will be needed to meet future SB 1953 requirements, such as anchorage and bracing to resist lateral loads.

In the event that emergency egress lighting does not exist, there is no requirement to install such lighting to meet the provisions of NPC-2.

---

## **POLICY**

### 1. General

- a. The following provisions apply only to the anchorage of selected components and systems to meet the requirements of NPC-2, as defined in Article 11, Chapter 6, California Administrative Code. Selected components of the following systems are included:

- i. Communications systems;

- ii. Emergency power supply;
  - iii. Fire alarm systems; and
  - iv. Emergency lighting equipment and exit signs in the means of egress.
- b. Components of bulk medical gas systems are not covered by this PIN.
- c. These provisions are not applicable to bracing and anchorage of equipment and systems for NPC-3, NPC-4, or NPC-5 compliance.

2. Submittals

- a. The engineer or architect of record shall provide design drawings in sufficient detail to permit an accurate description of the scope of the anchorage project. This will include plans showing descriptions and locations of the components to be braced or anchored, anchorage and bracing details, and general notes and specifications necessary to describe the work. Reference to this PIN and other pre-approved bracing standards may be made for anchorage of components covered therein. Supporting calculations are required for components not covered by this PIN or by other pre-approved anchorage systems.
- b. In the case of the emergency egress lighting system, the drawings shall clearly indicate the means of egress. Location of the emergency lighting fixtures in the means of egress need not be shown in the initial submittal. However, a note on the drawings shall clearly indicate that all fixtures on emergency power in the designated means of egress shall be supported. In addition, the drawings shall state that all fixtures outside the designated means of egress, but served by the same electrical circuit as those located in the designated means of egress, shall be supported.
- c. Prior to final approval of the project, the designer of record shall submit signed and stamped revised floor plans, indicating all emergency light fixtures that are supported as part of the project. The drawings shall also be amended to include any details, not indicated in the initial submittal, used to provide support for fixtures in locations where the approved details could not be implemented. The revised drawings shall be submitted to OSHPD for final review and approval.

3. Existing NPC-2 equipment weighing less than 20 lbs.

Existing NPC-2 equipment weighing less than 20 lbs. and not supported on vibration isolators shall be exempt from anchorage evaluation, except for the following items. The engineer of record shall evaluate the adequacy of the anchorage for these items regardless of weight of the component.

- a. Emergency egress lighting, including all fixtures outside the designated means of egress, but served by the same electrical circuit as those located in the designated means of egress;

- b. Ceiling-mounted exit signage;
- c. Emergency power and communications batteries;
- d. Emergency fuel transfer pumps; and
- e. Emergency power supply battery chargers.

4. Wall-mounted panels.

Fire alarm and emergency communication system panels meeting all of the following criteria may be exempt from anchorage calculation and fastener testing requirements:

- a. The panel is attached to any of the following:
  - i. Wood or metal stud framing;
  - ii. Blocking attached to wood or metal framing;
  - iii. Plywood adequately attached to wood or metal stud framing, reinforced concrete, or reinforced masonry;
  - iv. Reinforced concrete; or
  - v. Reinforced masonry.
- b. The panel has a minimum of one fastener at each corner;
- c. The panel weighs less than 100 lbs., is no deeper than 8 inches, and no larger than 12 square feet in elevation, and
- d. The engineer of record has certified, in writing, on the plans that he or she has personally viewed and evaluated the existing anchorage of the fire alarm panel and found it to be adequately anchored to resist the applicable code prescribed forces.

5. Emergency egress lighting and exit signage.

a. General.

The methods and details provided in this document indicate acceptable methods for achieving compliance for NPC-2 emergency egress lighting and exit signage support. The intent of this PIN is to provide for reliable vertical support for these fixtures only. Additional lateral bracing of these fixtures may be needed to meet NPC-3, NPC-4, and NPC-5 requirements.

- i. Strings of lighting fixtures 2 feet by 4 feet or smaller, whether attached or detached, shall have two slack safety wires per fixture located at diagonally opposite corners. Strings of fixtures greater than 2 feet by 4 feet, but no larger than 4 feet by 4 feet, whether attached or detached, shall have four slack safety wires per fixture, one slack safety wire at each corner.
  - ii. Fasteners used to connect light fixtures or exit signs to ceiling grid members, ceiling framing or runners, supplemental framing or blocking, and joists, trusses, or other structural elements shall meet the following criteria:
    - 1) Fasteners for fixtures shall be sheet metal screws, bolts or other approved support devices;
    - 2) The fasteners must each be capable of supporting 100% of the weight of the fixture;
    - 3) Positive clamping to supporting members with devices made of material with a minimum of 14-gage thickness is acceptable;
    - 4) Rotational spring catches do not comply, and shall not be used for this application; and
    - 5) Fasteners in plaster or gypsum board are not acceptable.
  - iii. Where spreader bars are used to support light fixtures, they shall be 1½ inch cold rolled 16-gage channels weighing 0.475 lbs. per foot. Positive attachment of the spreader bars to the main ceiling runners is required, and shall consist of sheet metal screws, bolts, saddle-tied single strand 16-gage wire or saddle-tied double strand 18-gage wire, or other approved support devices.
- b. Recessed Light Fixtures
- i. Existing recessed emergency egress lighting fixtures or exit signs weighing less than 56 lbs., hung from suspended acoustical lay-in and concealed spline ceiling systems, may be supported by the following methods.
    - 1) Lighting fixtures 2 feet by 4 feet or smaller shall have two 12-gage slack safety wires attached to the fixture at diagonal corners. Lighting fixtures no larger than 4 feet by 4 feet may be supported by providing four 12-gage slack safety wires, one at each corner.
    - 2) Alternatively, the fixture may be supported by positively attaching the fixture to the ceiling grid members as described below:
      - A. Lighting fixtures 2 feet by 4 feet or smaller shall be provided with fasteners at diagonal corners. Lighting fixtures no larger than 4 feet by 4 feet may be supported by providing fasteners at each corner. Fasteners shall each be

capable of supporting 100% of the weight of the fixture.

- B. A slack safety wire support to the ceiling grid shall be provided within 6 inches of each point where the fixture is attached to ceiling grid.
- ii. Existing recessed emergency egress lighting fixtures or exit signs weighing less than 56 lbs., hung from wire suspended drywall, plaster, or hard ceiling systems may be supported by positively attaching the fixture to the main runners, or supplemental framing that is supported by the main runners. Lighting fixtures or exit signs attached to a drywall, plaster, or hard ceilings supported directly on wood or metal joists, trusses, or other structural members (exposed joists, trusses, concrete, steel beams, metal deck, etc.) may be supported by positively attaching the fixture to the supporting element or to supplemental framing or blocking that is carried by the supporting element.
  - 1) Lighting fixtures with dimensions no larger than 2 feet by 4 feet shall be attached to the main runners, spreader bars, supplementary framing, trusses, joists, blocking or structural elements of the building with four fasteners, one at each corner. If it is determined to be unfeasible to install fasteners at each corner, a minimum of two fasteners, one at each diagonal corner, or at each end of the fixture centerline, may be used.
  - 2) Lighting fixtures with dimensions no larger than 4 feet by 4 feet shall be supported by positively attaching the fixture to the main runners, spreader bars, supplementary framing, trusses, joists, blocking or structural elements of the building with a minimum of four fasteners, one on each corner. The fasteners shall be placed within 6 inches of each corner of the fixture.
  - 3) As an alternative, these fixtures may also be supported with slack safety wires. The slack safety wire supports shall meet the requirements for fixtures hung from suspended acoustical lay-in ceiling systems.

c. Surface-Mounted Light Fixtures

- i. Existing surface-mounted emergency egress lighting fixtures or exit signs weighing less than 56 lbs., hung from suspended acoustical lay-in and concealed spline ceiling systems, may be supported by positively attaching the fixture to the ceiling grid members.
  - 1) Lighting fixtures with dimensions no larger than 2 feet by 4 feet shall have a minimum of two positive anchorage devices, at diagonal corners. Lighting fixtures no larger than 4 feet by 4 feet may be supported by positively attaching the fixture to two ceiling grid members with a minimum of four positive anchorage devices (one attachment at each corner of the fixture). The fixture shall be attached to the ceiling grid within 6 inches of each corner of each fixture.

- 2) Anchorage devices shall consist of screws, pop, rivets or positive anchorage devices that surround the ceiling runner that are each capable of supporting 100% of the weight of the fixture.
  - 3) A slack safety wire support to the ceiling grid shall be provided within 6 inches of each fixture attachment point.
- ii. Existing surface-mounted emergency egress lighting fixtures or exit signs mounted on wire suspended drywall, plaster, or hard ceiling systems may be supported by positively attaching the fixture to the main runners, spreader bars, or supplemental framing that is supported by the main runners. Surface-mounted lighting fixtures or exit signs attached to a drywall, plaster, or hard ceiling supported directly on wood, or metal joist, trusses, other structural elements may be supported by positively attaching the fixture to the supporting element, or supplemental framing, or blocking that is supported by the element as follows:
- 1) Lighting fixtures with dimensions larger than 2 feet by 4 feet may be supported by positively attaching the fixture to the main runners, spreader bars, supplemental framing, trusses, joists, blocking or structural elements with four fasteners, one at each corner. If it is determined to be unfeasible to install fasteners at each corner, a minimum of two fasteners, one at each diagonal corner or at each end of fixture centerline may be used.
  - 2) Existing recessed or surface-mounted emergency egress lighting fixtures with dimensions no larger than 4 feet by 4 feet may be supported by positively attaching the fixture to the main runners, spreader bars, supplemental framing, trusses, joists, blocking or structural elements with a minimum of four fasteners, one at each corner. The fasteners shall be placed within 6 inches of each corner of the fixture.
  - 3) These fixtures may also be supported with slack safety wires (see Section 5.b.i for slack safety wire support requirements).

d. Pendant-mounted Light Fixtures

- i. Pendants that support less than 28 lbs. each may be supported with 12-gage slack safety wires attaching directly to structure above the ceiling system. Where pendants support more than 28 lbs., but less than or equal to 56 lbs., two 12-gage slack safety wires shall be used.
  - 1) The slack safety wires must pass through each pendant hanger and be capable of supporting four times the weight of the fixture.
  - 2) Chain hung pendant-mounted light fixtures must have closed hooks at chain attachment points.

- A. If a pendant-mounted light fixture is chain hung the fixture need not have slack safety wires from the light fixture to the supporting closed hook attached to an outlet box; however, the outlet box must be supported by slack safety wires to the structure above. The closed hook must be positively attached the outlet box by fasteners capable of supporting four times the weight of the fixture.

*Exception:* The slack safety wires supporting the outlet box may be omitted on chain-hung fixtures, if the outlet box is securely anchored to joists or trusses (or supplemental framing or blocking that is supported by joists or trusses) or to the structure above by fasteners capable of supporting four times the weight of the fixture.

- 3) Pendant-mounted light fixtures must be able to swing about their pendant mounting supporting point up to 45 degrees in all directions without contacting obstructions; or they must be restrained by wires or cables from swinging movement in the direction of the obstruction.

#### e. Ceiling-Mounted Exit Signs

- i. Existing exit signs weighing less than 28 lbs. may be supported using the following methods:
  - 1) Exit signs supported by positively attaching the fixture, or outlet box, (where fixture is securely attached to an outlet box) to the building structure with screws, bolts, or other positive fastener each capable of supporting 100% of the weight of the fixture.
  - 2) In suspended ceiling systems, exit signs weighing less than 28 lbs. may be supported by a slack safety wire to the structure, attached directly to the fixture or outlet box with fasteners capable of supporting 100% of the weight of the fixture. The fixture shall be securely attached to the outlet box.
  - 3) Exit signs may be supported by positively attaching the fixture, or outlet box, (where fixture is securely attached to an outlet box) to a main runner or by supplemental framing that is supported by main runners, with screws each capable of supporting 100% of the weight of the fixture.

#### 6. Safety Wires

- a. New slack safety wires shall be of minimum 12-gage “galvanized” soft annealed mild steel wire and conform to ASTM A 641.
- b. Where possible, slack safety wires shall run plumb from their support locations to the loads they support. Where it is not possible for the slack safety wires to run plumb, in no case shall they run at an angle of less than 45 degrees from horizontal. Where

slack safety wires run more than 1 in 6 out of plumb, additional slack safety wires shall be provided to offset the resulting horizontal force by bracing, counter splaying or other acceptable means. Slack safety wires may not be bent around conduits, ducts, pipes or their covering materials. Slack safety wire attachment loops shall have 3 tight turns of the wire within 1 ½ inch at each end of the wire. Slack safety wires may be supported by any one of the following specified or detailed methods shown in this document.

- c. Slack safety wire support.
  - i. Concrete. Attachment to concrete may be accomplished using shot-pin or drilled-in concrete anchors. When drilled-in concrete anchors, or shot-in anchors are used in reinforced concrete for slack safety wires 1 out of 10 must be field-tested for 200 pounds in tension. If any shot-in or drilled-in anchor fails, then all adjacent anchors must be tested. New 12-gage slack safety wires may be spliced onto existing 12-gage or larger hanger wires as long as 100% of the spliced wires are tension tested to 200 lbs. See Details 3.1 and 3.2.
  - ii. Wood. See Details 3.4 and 3.6.
  - iii. Steel. See Details 3.4 and 3.5.
- d. If no practical method of support for slack safety wires can be found, and all known methods for the support have been considered, and found to be impractical, slack safety wires may be attached to existing trapeze supporting pipe, conduit, and ducts, or to existing individual pipe, conduit, or duct hanger rods. The slope of the slack safety wire may be no more than 1 in 6 out of plumb.
  - i. Slack safety wires shall not be attached to hangers or trapezes that support a fire sprinkler line, fire alarm conduit, or cable.
  - ii. When attaching to a trapeze or individual hangers the minimum diameter of the hanger rod shall be 3/8 inch.
  - iii. Attachment to individual 3/8 inch or larger hanger rods may be made by tightly looping the splay wire twice around the hanger rod with a slip on nut below for support, and terminating the wire with 3 tight turns within 1½ inches. Additional attachment configurations are shown in Details 3.8 and 3.9.
  - iv. Supplemental framing may be added above corridors to provide support for the safety wires. See Details 5.1 and 5.2.

Original signed  
Paul Coleman

9/19/11  
Date



**NPC-2 SUPPORT REQUIREMENTS FOR EMERGENCY LIGHTING EQUIPMENT AND EXIT SIGNS IN THE MEANS OF EGRESS****A. GENERAL**

These notes refer to prescriptive details that will satisfy NPC-2 criteria for non-compliant emergency lighting equipment and exit signs in the means of egress. The primary intent of these details is to provide reliable vertical suspension after an earthquake. Bracing for lateral forces is not provided.

**B. SOFT CEILINGS (LAY-IN OR CONCEALED SPLINE)**

- 1) Recessed light fixtures
  - a) 2' x 4' or smaller fixture modules shall have two slack suspension wires located at diagonally opposite corners of each fixture. Strings or aligned groups of such fixtures, whether attached or detached, shall have two slack suspension wires located at diagonally opposite corners of each 2' x 4' or smaller fixture module. See detail 1.1.
  - b) 4' x 4' fixture modules shall have one slack suspension wire at each corner of each fixture. Strings or aligned groups of such fixtures, whether attached or detached, shall have one slack suspension wire at each corner of each 4' x 4' fixture module. See detail 1.2.
- 2) Surface mounted light fixtures
  - a) 2' x 4' or smaller fixture modules shall be attached to ceiling tees at two locations of each fixture. See detail 1.5.
  - b) 4' x 4' fixture modules shall be attached to ceiling tees within 6 inches of each corner of each fixture. See detail 1.5 (similar).
  - c) Minimum fasteners for attachment to ceiling tees shall consist of 1/8 inch diameter pop rivets, no. 10 sheet metal screws, or other approved connectors.
  - d) Slack suspension wires shall be located within six inches from the attachment of the fixture to the ceiling tees.
  - e) Alternately, fixtures may utilize slack suspension wires in a similar manner as for "recessed light fixtures", details 1.1 or 1.2.
- 3) Pendant mounted light fixtures
  - a) Provide one wire within pendant suspension tube connecting fixture to electrical junction box.
  - b) Provide one slack suspension wire from electrical junction box at ceiling to structure above.
- 4) Exit signs: Provide one slack suspension wire from electrical junction box to structure above. See detail 1.6.

**C. HARD CEILINGS (PLASTER OR GYPSUM BOARD)**

Recessed or surface mounted light fixtures, pendant mounted light fixtures and exit signs:

- 1) 2' x 4' or smaller fixture modules shall be positively attached to the main ceiling runners with fasteners at diagonally opposite corners of each fixture. Alternately, 2' x 4' or smaller fixture modules may be fastened to spreader bars with fasteners at diagonally opposite corners of each fixture and spreader bars positively attached to the main ceiling runners at each end of each spreader bar. See details 2.1 or 2.2. Fixtures may be alternately be fastened directly to existing steel ceiling joists per detail 2.3 (similar).
- 2) 4' x 4' fixture modules shall be positively attached to the main ceiling runners with fasteners within 6 inches of each corner of each fixture. Alternately, 4' x 4' fixture modules may be positively attached to spreader bars with fasteners within 6 inches of each corner of each fixture and spreader bars positively attached to the main ceiling runners at each end of each spreader bar. See details 2.1 (similar) or 2.2 (similar). Fixtures may be alternately be fastened directly to existing steel ceiling joists per detail 2.3.
- 3) Fasteners for fixtures shall be sheet metal screws, bolts, or other approved support devices built into the fixtures. Rotational spring catches are not acceptable.
- 4) Positive attachment of spreader bars to main ceiling runners shall consist of sheet metal screws, bolts, saddle-tied single strand 16 gage wire or saddle-tied double strand 18 gage wire, or other approved support devices.
- 5) Attachment of fixtures to plaster or gypsum board is not adequate.
- 6) Alternately, fixtures may utilize slack suspension wires in a similar manner as for "recessed light fixtures in soft ceilings" per details 1.1 or 1.2.

**D. FIXTURES IN AREAS WITHOUT CEILINGS**

- 1) Suspended fixtures must be free to swing a minimum of 45 degrees from vertical in all directions without contacting obstructions. Otherwise, suspended fixtures shall be restrained to prevent swing.
- 2) Pendant suspension systems shall have a wire connection between fixture and electrical junction box. Junction box must be securely anchored to building structure. Attachment must be adequate to resist 4 times the weight suspended by the junction box.
- 3) Chain hung fixtures shall have closed hook connections at ends of chains.

**E. SLACK SUSPENSION WIRES**

- 1) Slack suspension wires shall be 12 gauge minimum, galvanized and conform to ASTM A 641.
- 2) Each end of each slack suspension wire shall have a minimum of three tight turns in 1-1/2 inches.
- 3) Slack suspension wires shall not be more than 1 in 6 out of plumb.  
Exception: Wires may be more than 1 in 6 out of plumb, to a maximum angle of 45 degrees, if additional counter-sloping wires are installed to avoid excessive twist or swing of the fixture, assuming support of the fixture is provided solely by the slack suspension wires.
- 4) Slack suspension wires shall not bend around ducts, pipes, conduits or other interfering obstructions.
- 5) Slack suspension wires shall be directly attached to the structure above. See details 3.1, 3.2, 3.3, 3.4, 3.5, or 3.6, as applicable. Attachment of slack suspension wires to ceilings, ducts, pipes, conduits, pipe hangers or trapezes is not permitted.  
Exceptions when slack suspension wires are not more than 1 in 6 out of plumb:
  - a) Slack suspension wires may be attached to existing pipe hangers or trapezes if the pipe hangers or trapezes are supported by 3/8 inch diameter rods or greater. See details 3.7 or 3.8.
  - b) Slack suspension wires may be attached to spreader bars. For spans not exceeding 48 inches, see detail 4.1. For spans not exceeding 96 inches, see detail 4.2.
- 6) Alternately, slack suspension wires may be attached to channel struts in corridors that are 10 feet wide or less. See detail 5.1. For channel strut properties, see detail 5.5.
- 7) Where drilled-in concrete anchors or shot-in anchors are used in reinforced concrete or for steel deck with concrete fill, 1 out of 10 anchors must be field tested for 200 pounds in vertical tension. If any shot-in or drilled-in anchor fails, test all adjacent anchors.

**F. 1-1/2 INCH COLD ROLLED STEEL CHANNELS**

- 1) 1-1/2 inch cold rolled channels shall be made from 16 gage steel and weigh 0.475 pounds per foot.
- 2) Steel shall have a yield strength of at least 33 kips per square inch.
- 3) Minimum cross section properties shall be:  $A = 0.129$  inches<sup>2</sup>,  $I_x = 0.039$  inches<sup>4</sup>,  $S_x = 0.052$  inches<sup>3</sup>, and  $I_y = 0.002$  inches<sup>4</sup>.
- 4) Cold rolled channels shall be galvanized or black asphaltum painted.

**APPROVED**  
For NPC-2 Compliance only



May 7, 2001

Office of Statewide Health  
Planning and Development  
Facilities Development Division

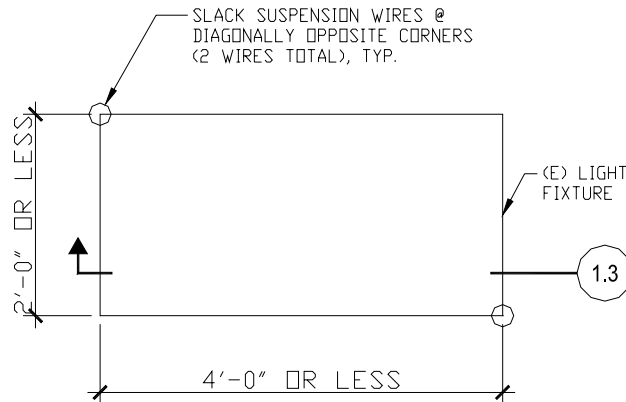

1.1 PLAN-SUSPENSION OF 2'x4' OR SMALLER FIXTURES AT LAY-IN OR CONCEALED SPLINE CEILING

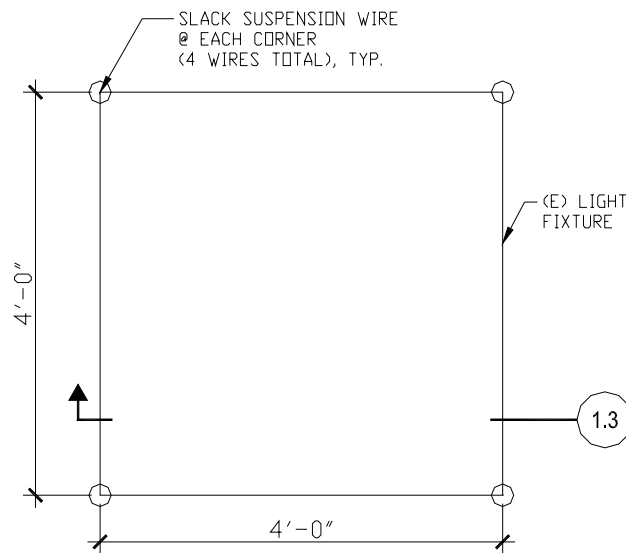

1.2 PLAN - SUSPENSION OF 4'x4' FIXTURES AT LAY-IN OR CONCEALED SPLINE CEILING

**APPROVED**  
 For NPC-2 Compliance only  
  
 May 7, 2001  
 Office of Statewide Health  
 Planning and Development  
 Facilities Development Division

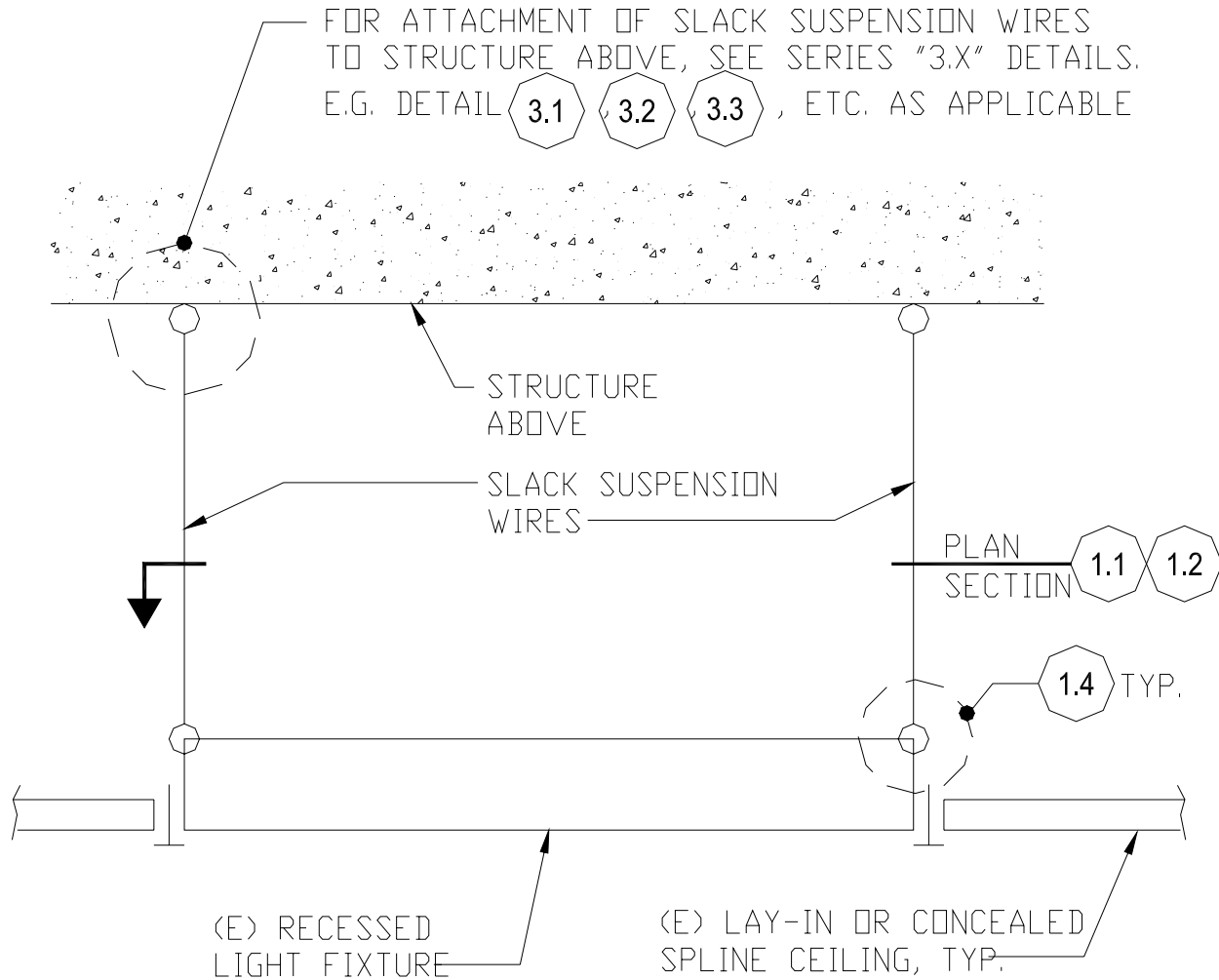

1.3 ELEVATION - SLACK SUSPENSION WIRES FOR RECESSED LIGHT FIXTURE AT LAY-IN OR CONCEALED SPLINE CEILING

APPROVED  
For NPC-2 Compliance only  
*[Signature]*  
May 7, 2001  
Office of Statewide Health  
Planning and Development  
Facilities Development Division

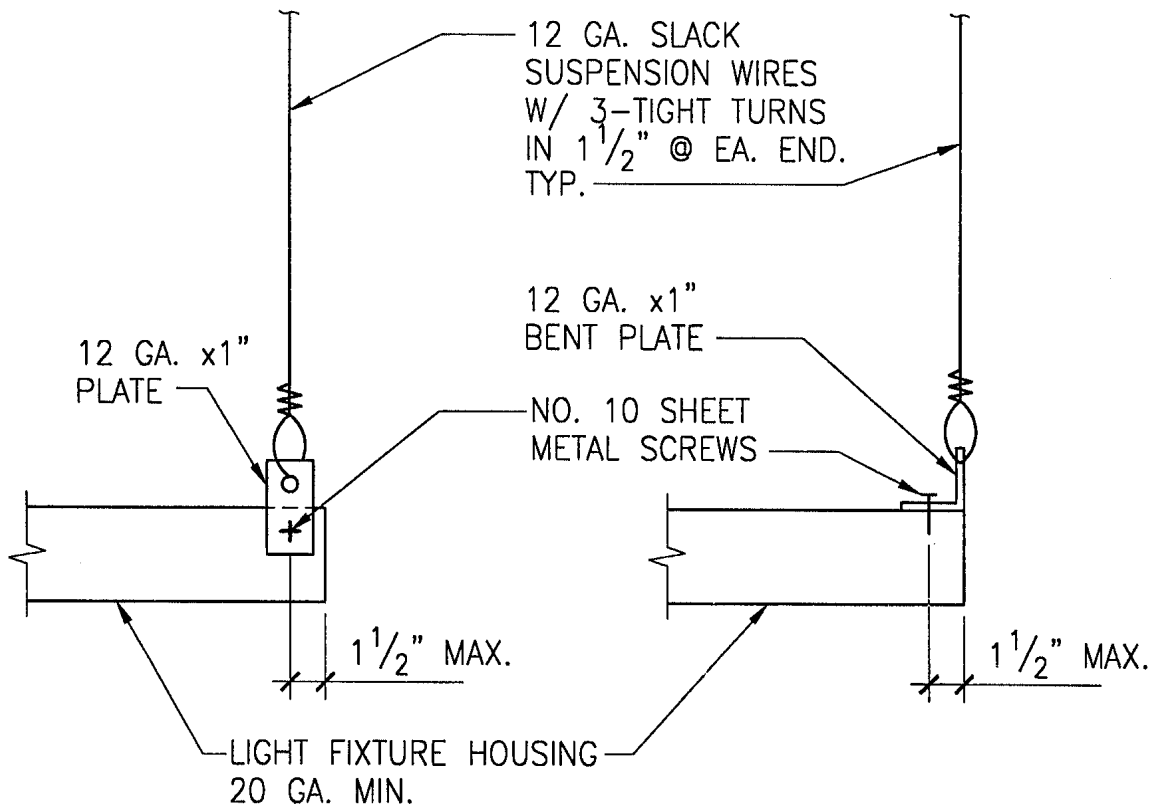

NOTE: SLACK SUSPENSION WIRES MAY BE ATTACHED TO (E) FACTORY INSTALLED EYELETS IF PRESENT @ CORNERS OF LIGHT FIXTURES.

1.4

**ATTACHMENT OF SLACK SUSPENSION WIRES TO FIXTURES**

**APPROVED**  
 For NPC-2 Compliance only  
  
 May 7, 2001  
 Office of Statewide Health Planning and Development  
 Facilities Development Division

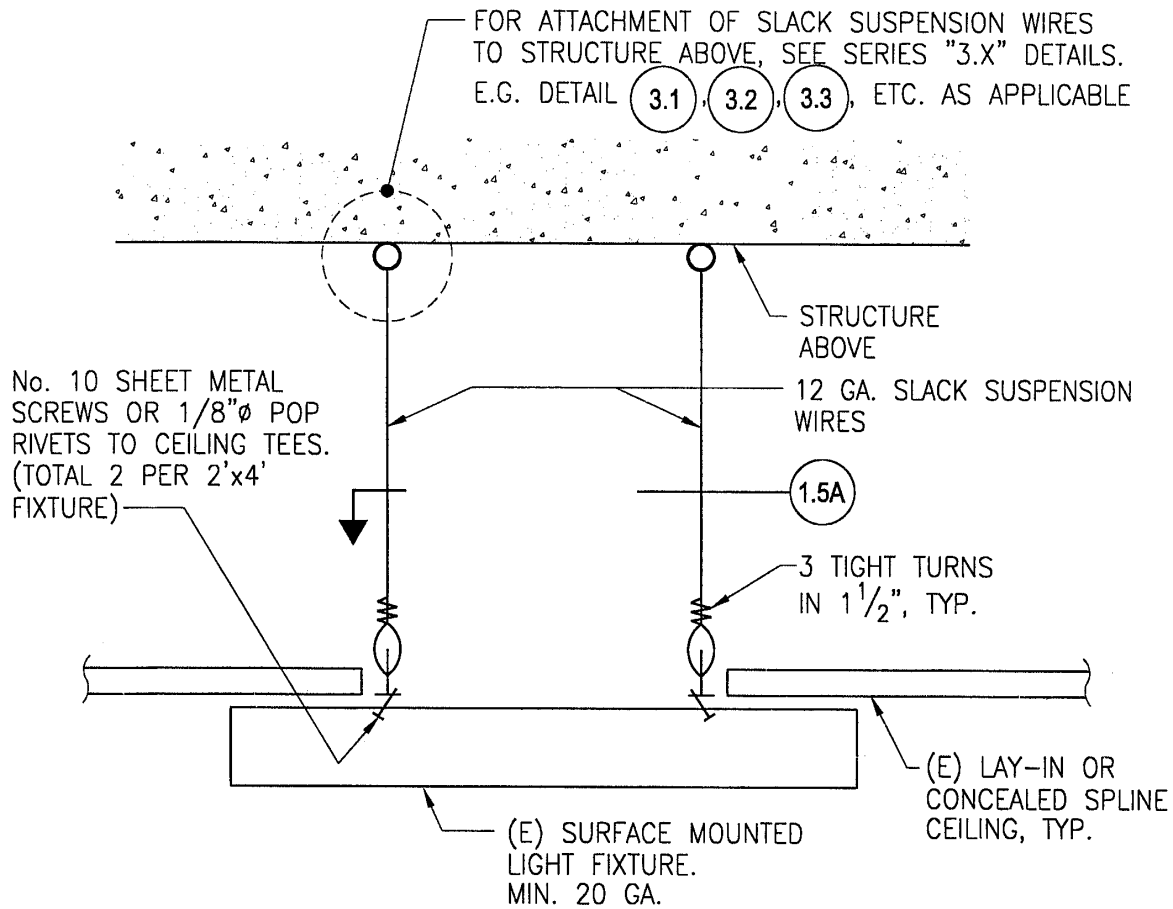

NOTE: DETAIL (1.3) MAY BE USED AS AN ALTERNATE.

ELEVATION

(1.5) **SUSPENSION OF SURFACE MOUNTED  
FIXTURES NOT LARGER THAN 2'x4' MODULE  
AT LAY-IN OR CONCEALED SPLINE CEILING**

**APPROVED**  
For NPC-2 Compliance only  
*[Signature]*  
May 7, 2001  
Office of Statewide Health  
Planning and Development  
Facilities Development Division

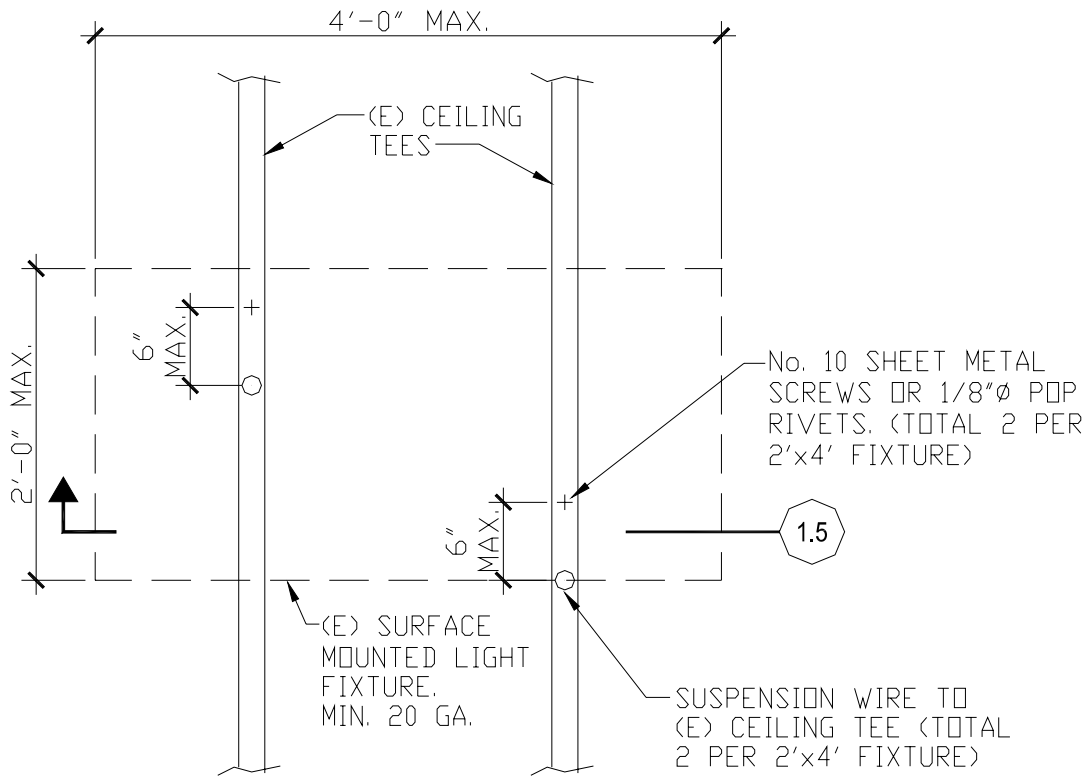

1.5A

# PLAN - SURFACE MOUNTED FIXTURES NOT LARGER THAN 2'x4' MODULE AT LAY-IN OR CONCEALED SPLINE CEILING

**APPROVED**

For NPC-2 Compliance only

May 7, 2001

Office of Statewide Health  
Planning and Development  
Facilities Development Division

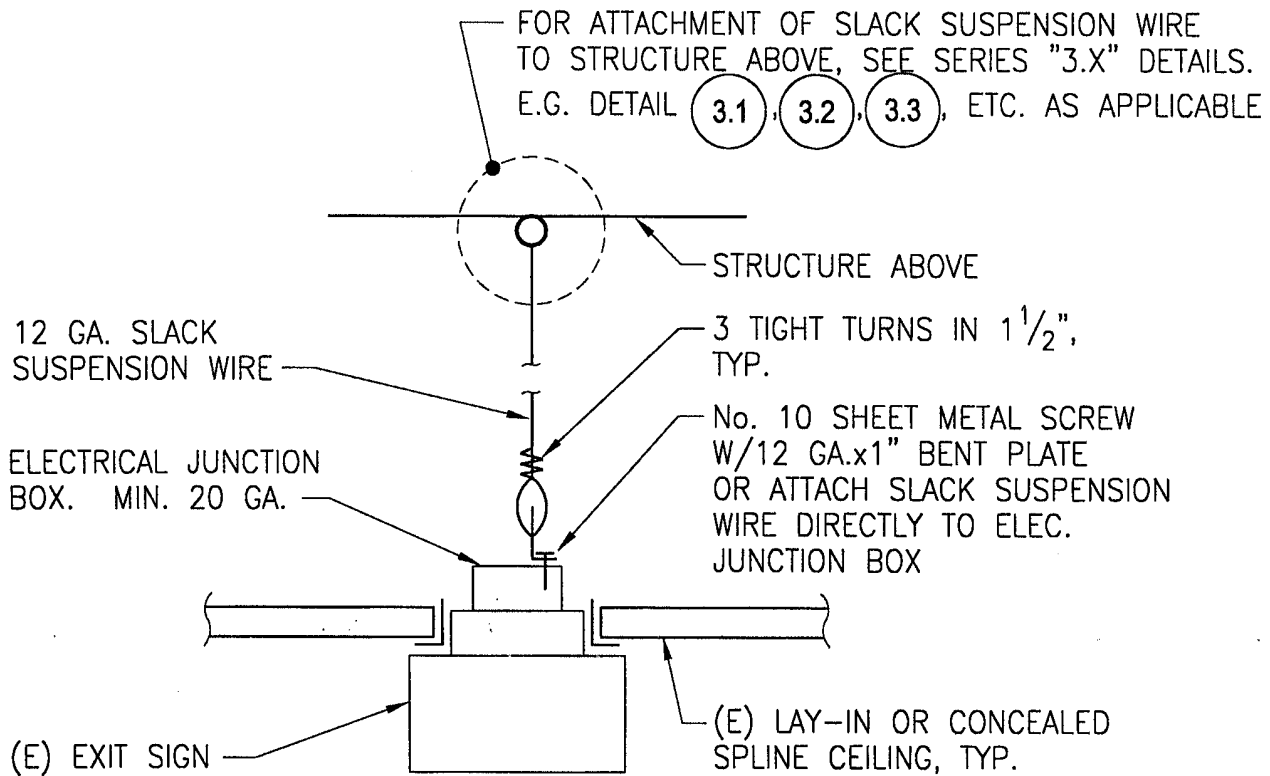

ELEVATION

1.6 SLACK SUSPENSION WIRE FOR EXIT SIGN AT LAY-IN OR CONCEALED SPLINE CEILING

**APPROVED**  
For NPC-2 Compliance only  
*[Signature]*  
May 7, 2001  
Office of Statewide Health  
Planning and Development  
Facilities Development Division



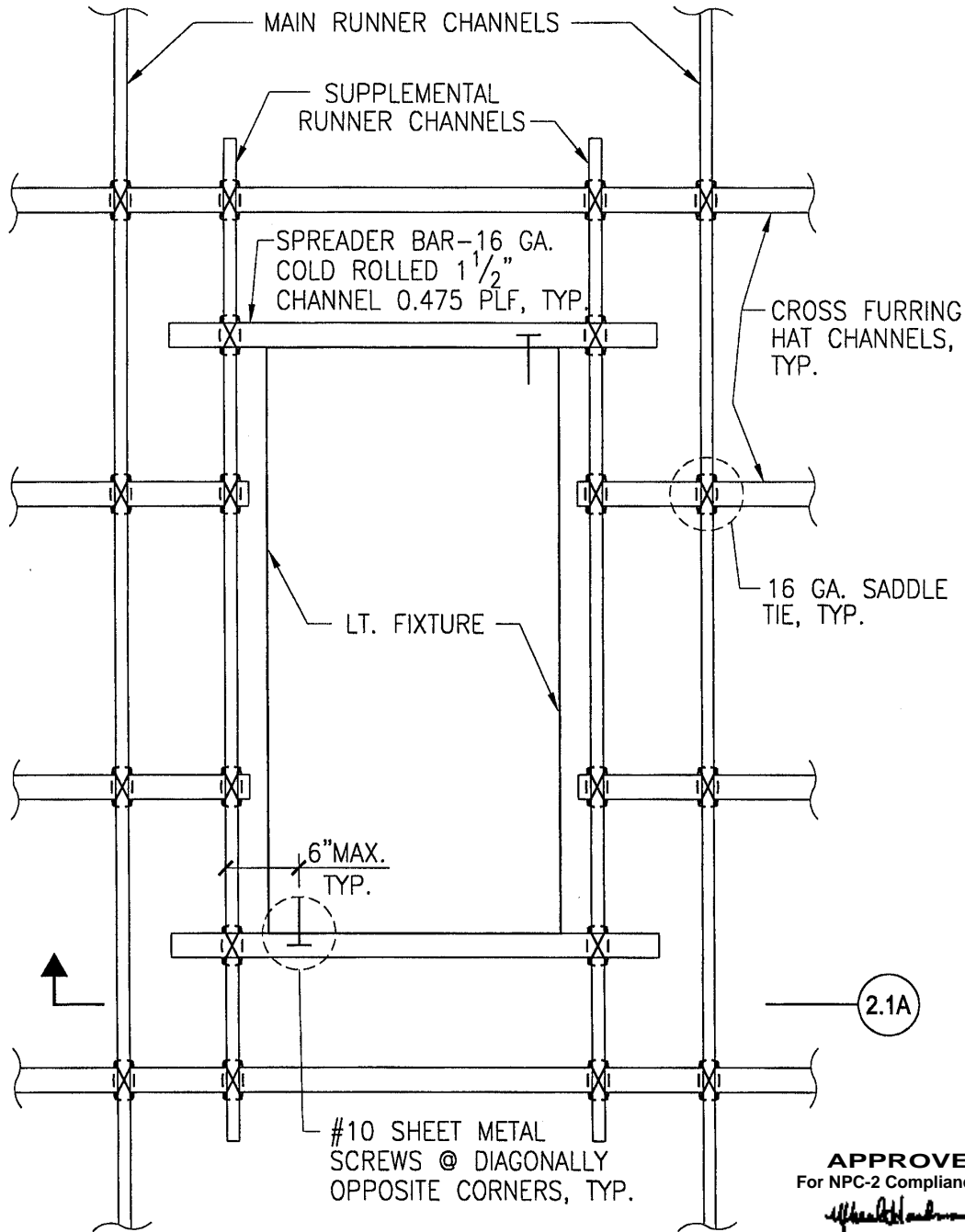

**PLAN**

- NOTES:**
1. VERT. HANGER WIRES NOT SHOWN.
  2. SLACK SUSPENSION WIRES NOT REQUIRED
  3. MIN. LT. FIXTURE = 20 GA.

**APPROVED**  
 For NPC-2 Compliance only  
*[Signature]*  
 May 7, 2001  
 Office of Statewide Health  
 Planning and Development  
 Facilities Development Division

2.1

**RECESSED LIGHT FIXTURES NOT LARGER THAN 2'x4' MODULE AT PLASTER OR GYPSUM BOARD CEILING**

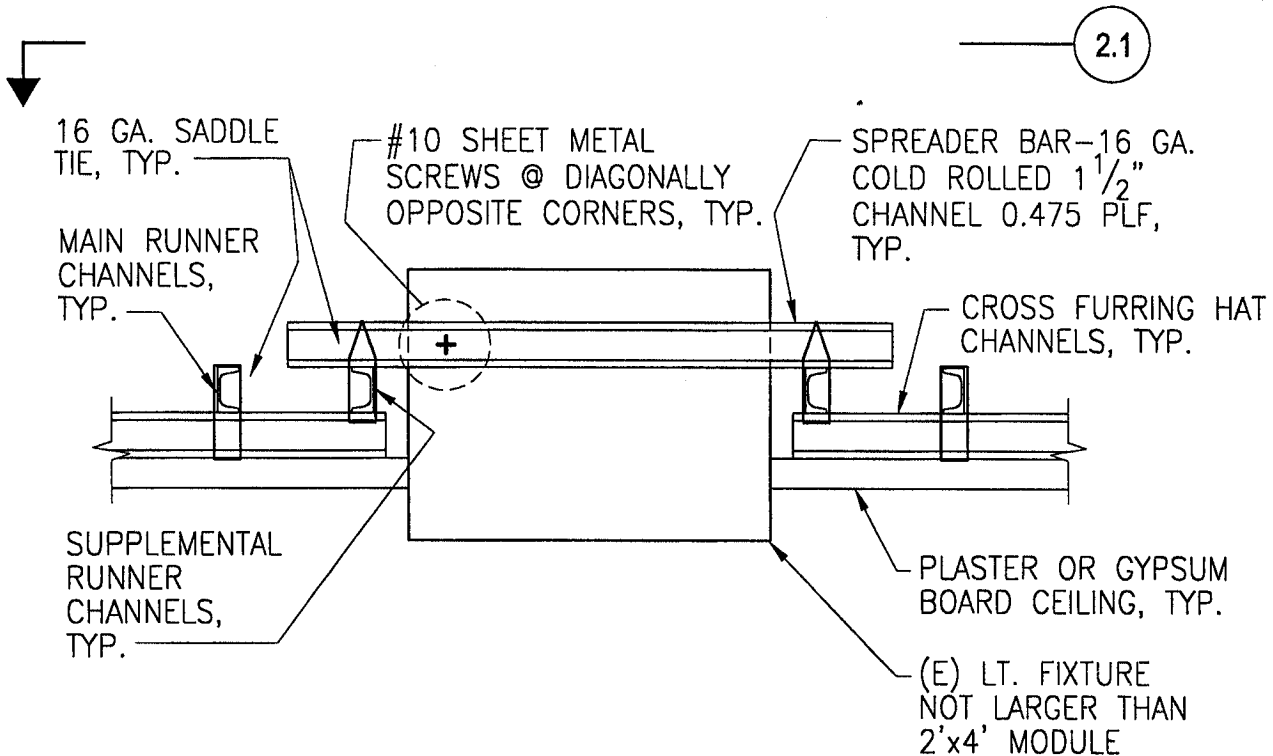

NOTES:

1. VERT. HANGER WIRES NOT SHOWN.
2. SLACK SUSPENSION WIRES NOT REQUIRED.
3. MIN. LT. FIXTURE = 20 GA.

**2.1A SECTION - RECESSED LIGHT FIXTURES NOT LARGER THAN 2'x4' MODULE AT PLASTER OR GYPSUM BOARD CEILING**

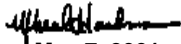
**APPROVED**  
 For NPC-2 Compliance only  
  
 May 7, 2001  
 Office of Statewide Health  
 Planning and Development  
 Facilities Development Division

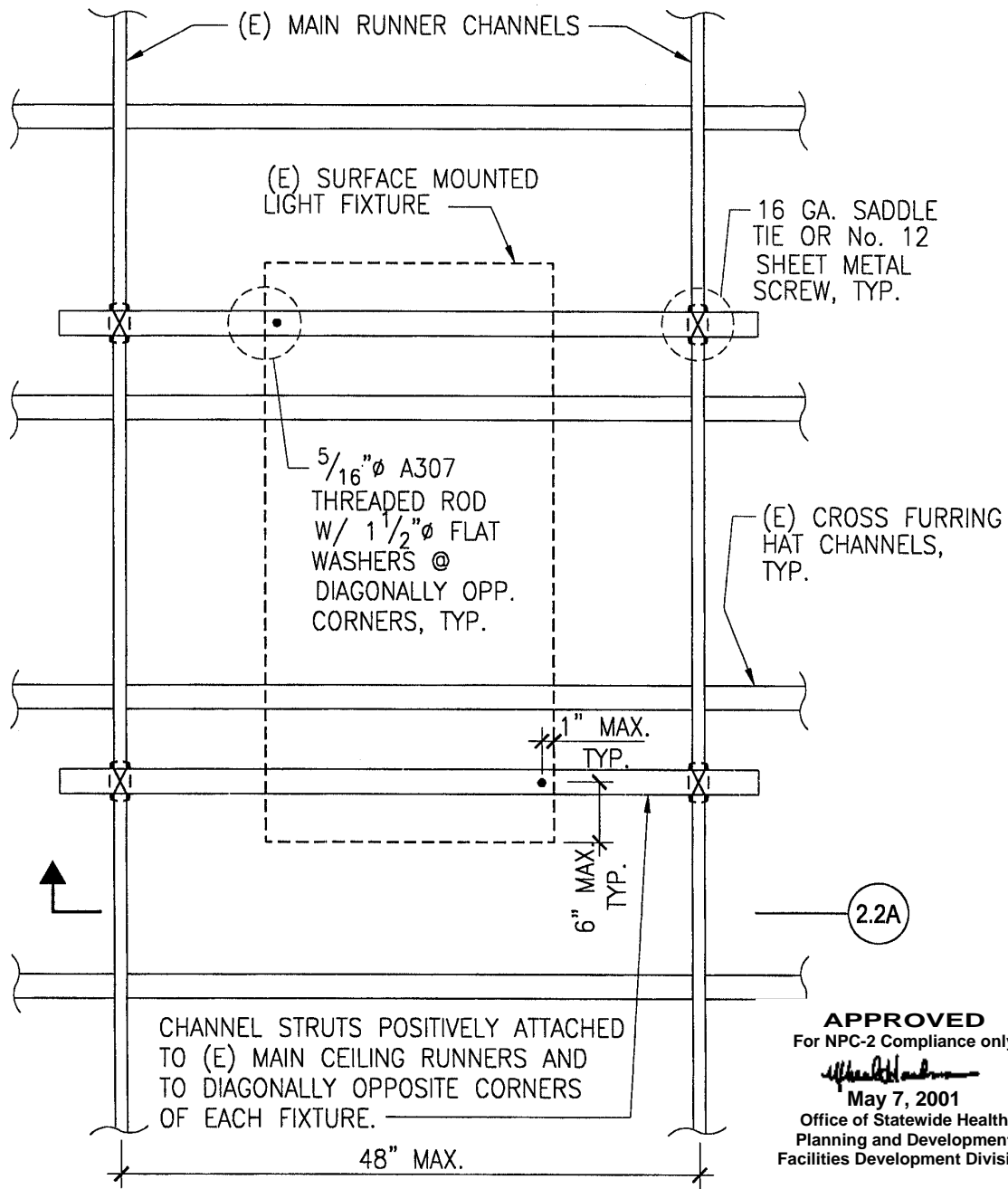

2.2A

**APPROVED**  
 For NPC-2 Compliance only  
*[Signature]*  
 May 7, 2001  
 Office of Statewide Health  
 Planning and Development  
 Facilities Development Division

**PLAN**

- NOTES:
1. VERT. HANGER WIRES NOT SHOWN.
  2. DETAIL (1.3) MAY BE USED AS AN ALTERNATE
  3. FOR PROPERTIES OF "CHANNEL STRUTS", SEE DETAIL (5.5)

**2.2 SURFACE MOUNTED FIXTURE NOT LARGER THAN 2'x4' MODULE AT PLASTER OR GYPSUM BOARD CEILING**

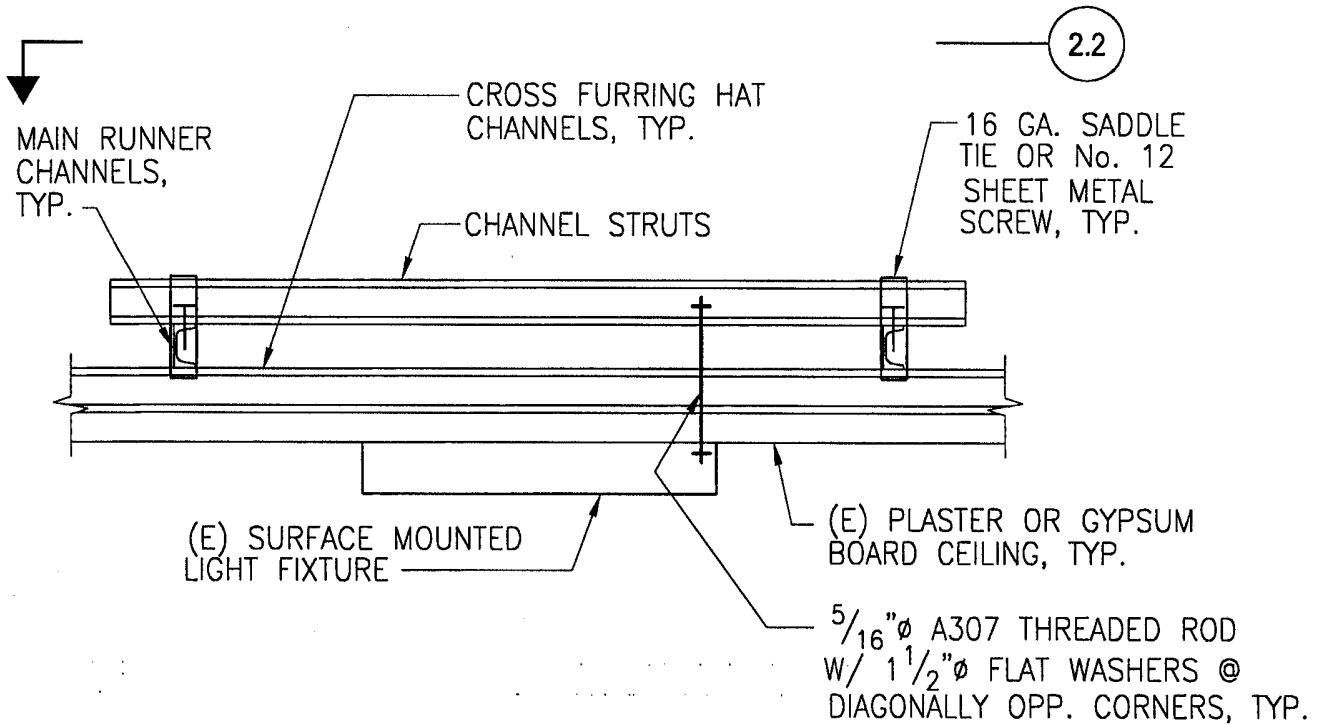

**APPROVED**  
 For NPC-2 Compliance only  
  
 May 7, 2001  
 Office of Statewide Health  
 Planning and Development  
 Facilities Development Division

**2.2A SECTION - SURFACE MOUNTED FIXTURE  
 NOT LARGER THAN 2'x4' MODULE AT  
 PLASTER OR GYPSUM BOARD CEILING**

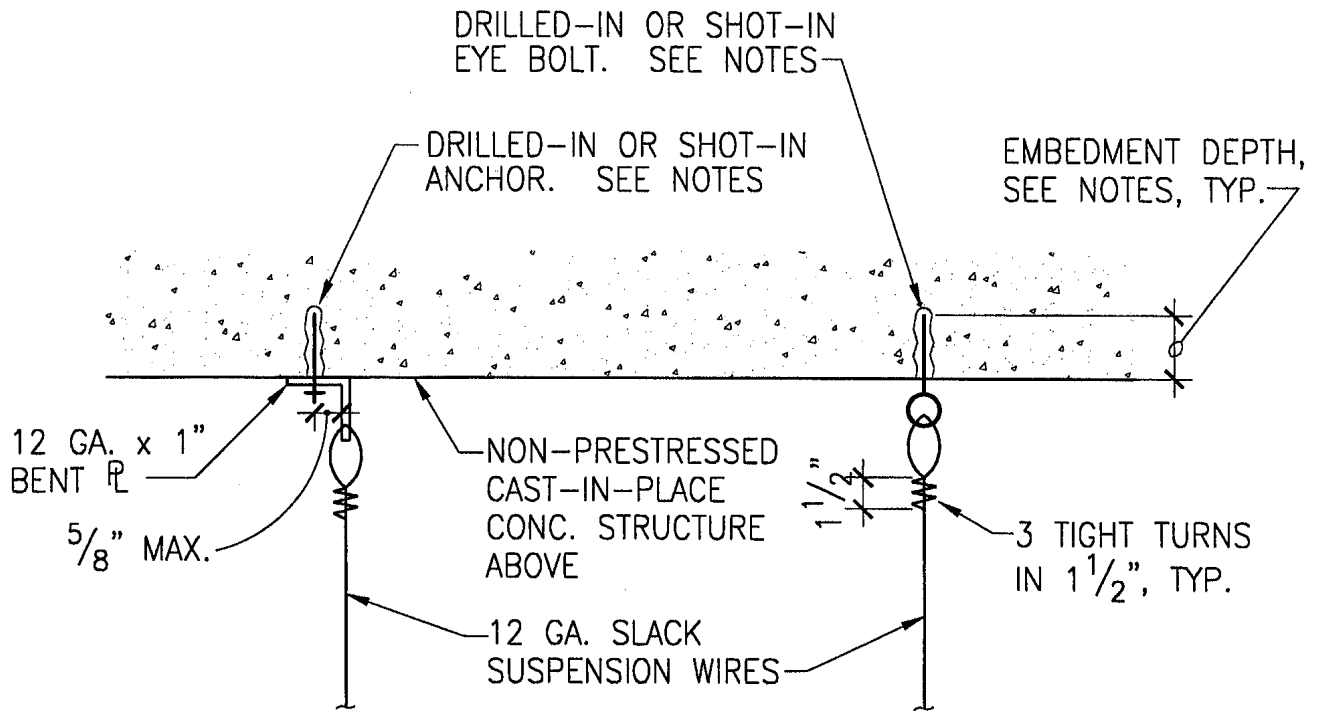

NOTES:

1. SLACK SUSPENSION WIRES MUST BE INSTALLED NOT MORE THAN 1 IN 6 OUT OF PLUMB. FOR EXCEPTIONS, SEE NOTES FOR "SLACK SUSPENSION WIRES".
2. DRILLED-IN ANCHORS SHALL BE MIN. 1/4"Ø WITH MIN. 2" EMBEDMENT INTO CONCRETE.
3. SHOT-IN ANCHORS SHALL BE MIN. 0.177"Ø WITH MIN. 1" EMBEDMENT INTO CONCRETE.
4. TEST 1 OUT OF 10 DRILLED-IN OR SHOT-IN ANCHORS OR EYE BOLTS FOR 200 POUNDS IN VERTICAL TENSION. IF ANY ANCHOR FAILS, SEE NOTES FOR "SLACK SUSPENSION WIRES".

**3.1 ATTACHMENT OF SLACK SUSPENSION WIRES TO NON-PRESTRESSED CAST-IN-PLACE CONCRETE**

4'x4') FASTEN DIRECTLY TO CEILING JOISTS @ PLASTER OR GYPSUM BOARD CEILING

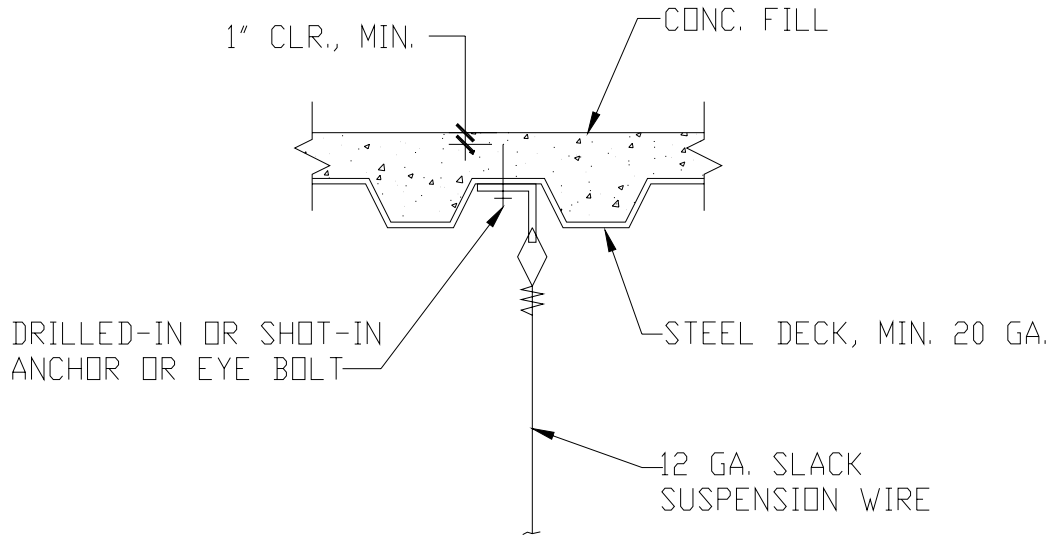

NOTE: FOR TYPICAL DETAILS NOT NOTED OR SHOWN, OR FOR ALTERNATE "EYE BOLT" ANCHOR, SEE DETAIL 3.1

3.2

## ATTACHMENT OF SLACK SUSPENSION WIRE TO STEEL DECK WITH CONCRETE FILL

**APPROVED**  
For NPC-2 Compliance only  
*[Signature]*  
May 7, 2001  
Office of Statewide Health  
Planning and Development  
Facilities Development Division

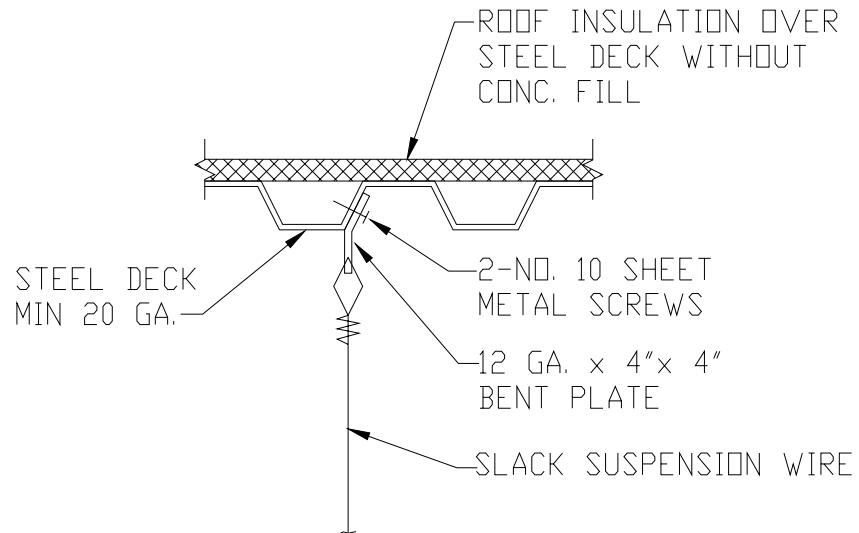

NOTE: FOR TYPICAL DETAILS NOT NOTED OR SHOWN, SEE DETAIL 3.1

3.3

## ATTACHMENT OF SLACK SUSPENSION WIRE TO STEEL DECK WITHOUT CONCRETE FILL

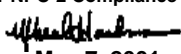
**APPROVED**  
For NPC-2 Compliance only  
  
May 7, 2001  
Office of Statewide Health  
Planning and Development  
Facilities Development Division

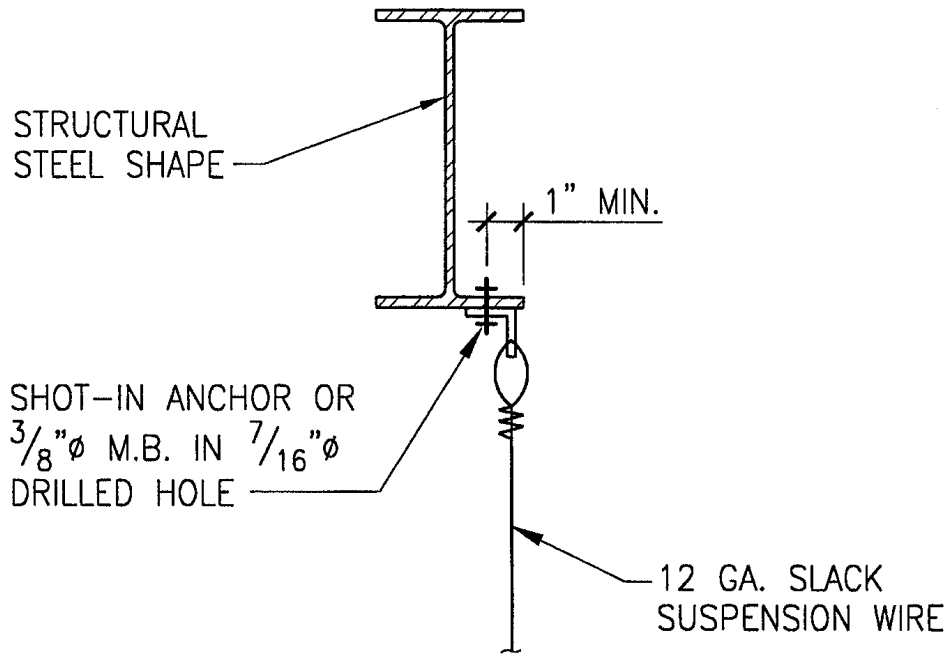

NOTE: FOR TYPICAL DETAILS NOT NOTED OR SHOWN, SEE DETAIL 3.1

3.4

## ATTACHMENT OF SLACK SUSPENSION WIRE TO STRUCTURAL STEEL SHAPES

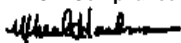
**APPROVED**  
For NPC-2 Compliance only  
  
May 7, 2001  
Office of Statewide Health  
Planning and Development  
Facilities Development Division



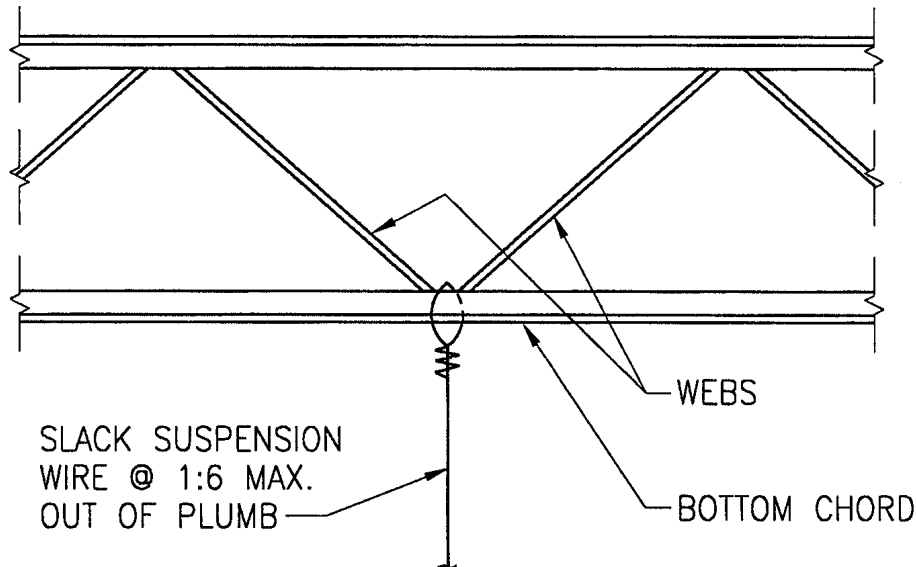

NOTES:

1. SLACK SUSPENSION WIRES MUST BE LOCATED AT INTERSECTION OF DIAGONAL WEBS AND BOTTOM CHORD AND MAY NOT BE MORE THAN 1 IN 6 OUT OF PLUMB.
2. FOR TYPICAL DETAILS NOT NOTED OR SHOWN, SEE DETAIL 3.1

3.5 **ATTACHMENT TO WOOD OR STEEL TRUSSES OR OPEN WEB JOISTS**

**APPROVED**  
 For NPC-2 Compliance only  
  
 May 7, 2001  
 Office of Statewide Health  
 Planning and Development  
 Facilities Development Division

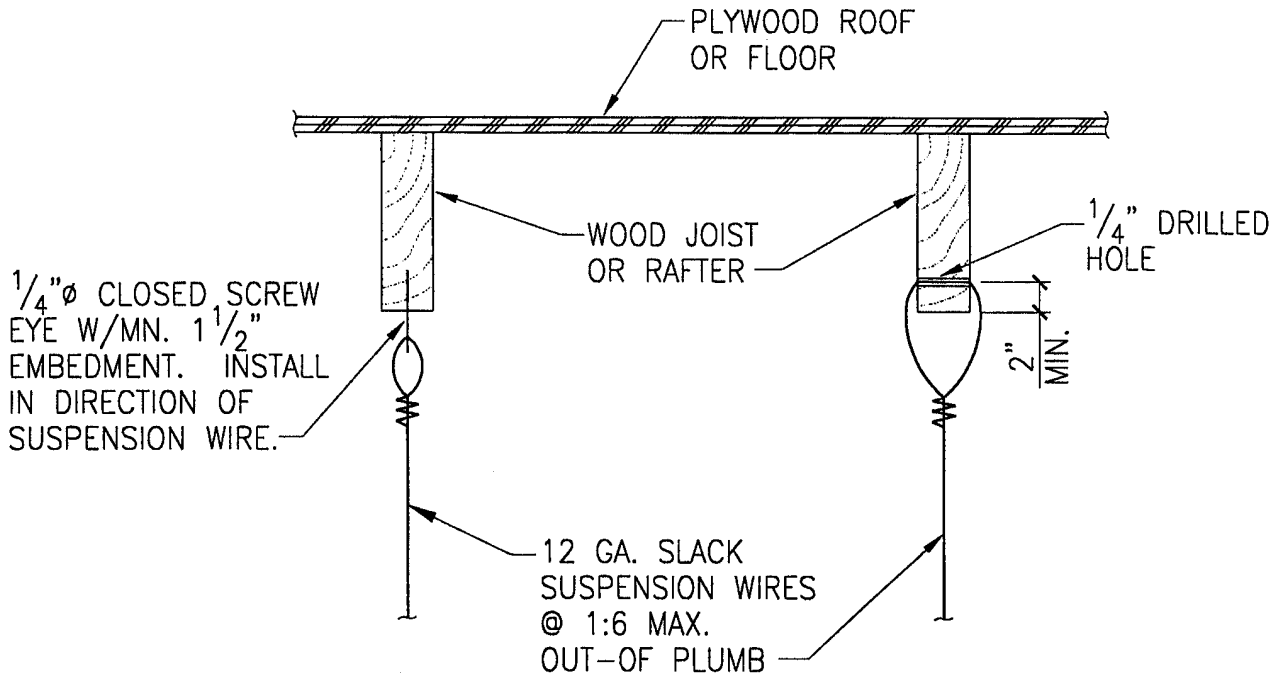

NOTE: FOR TYPICAL DETAILS NOT NOTED OR SHOWN, SEE DETAIL **3.1**

**3.6**

# ATTACHMENT OF SLACK SUSPENSION WIRES TO WOOD JOISTS OR RAFTERS

For NPC-2 Compliance only  
*[Signature]*  
May 7, 2001  
Office of Statewide Health  
Planning and Development  
Facilities Development Division

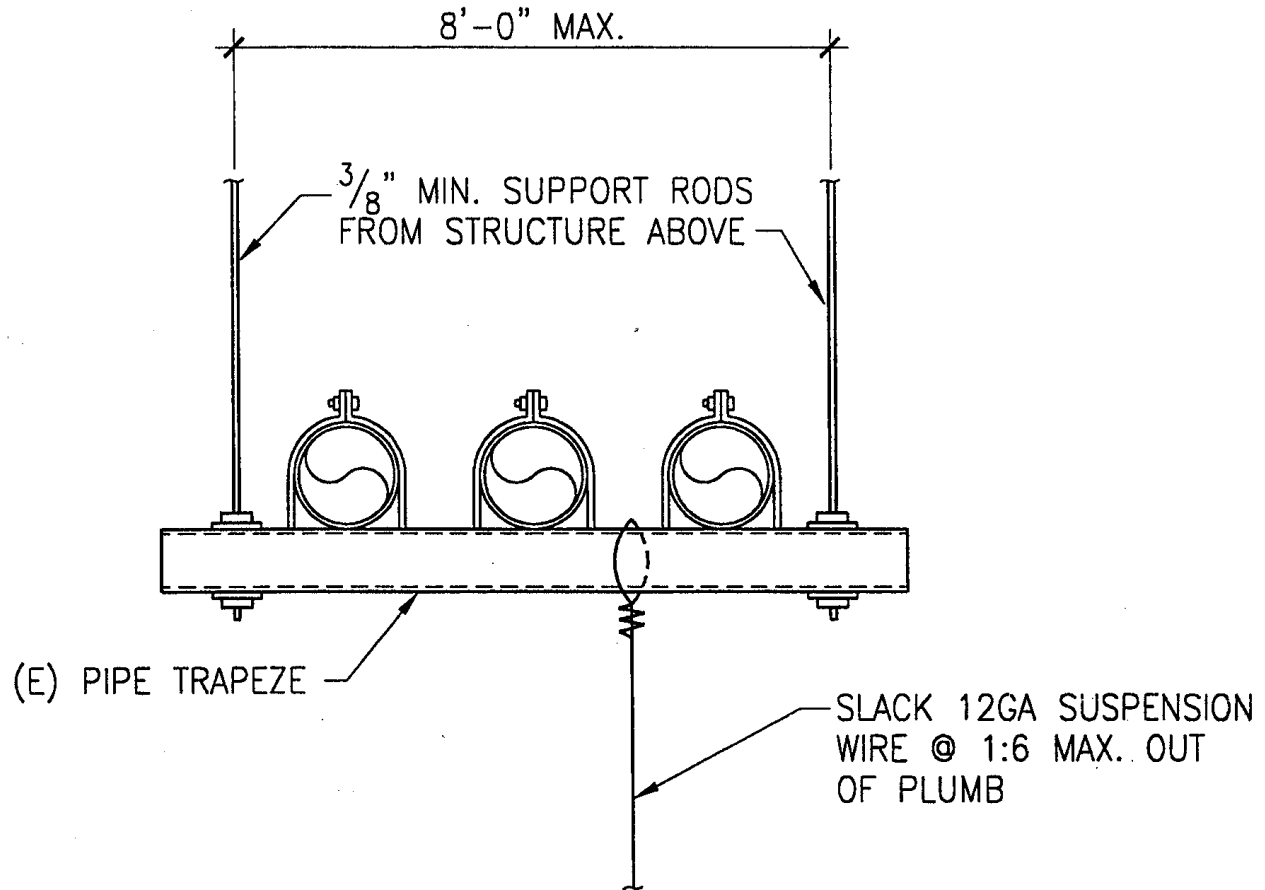

NOTE: FOR TYPICAL DETAILS NOT NOTED OR SHOWN, SEE DETAIL **3.1**

SLACK SUSPENSION WIRES SHALL NOT BE HUNG FROM FIRE SPRINKLER PIPE HANGERS OR TRAPEZE SUPPORTS

**3.7**

# ATTACHMENT OF SLACK SUSPENSION WIRES TO EXISTING PIPE TRAPEZE

APPROVED  
For NPC-2 Compliance only  
*[Signature]*  
May 7, 2001  
Office of Statewide Health  
Planning and Development  
Facilities Development Division

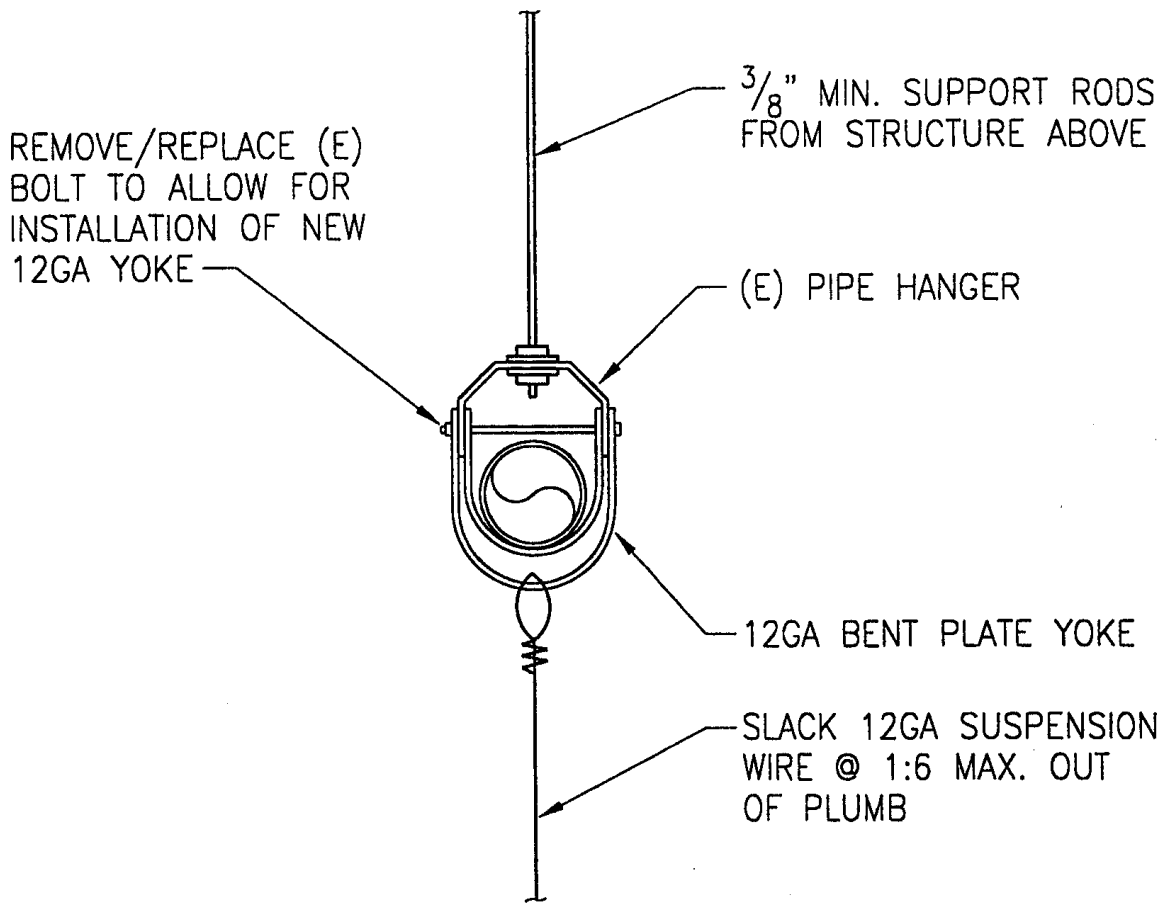

NOTE: FOR TYPICAL DETAILS NOT NOTED OR SHOWN, SEE DETAIL **3.1**

SLACK SUSPENSION WIRES SHALL NOT BE HUNG FROM FIRE SPRINKLER PIPE HANGERS OR TRAPEZE SUPPORTS

**3.8**

# ATTACHMENT OF SLACK SUSPENSION WIRES TO SINGLE PIPE HANGER

**APPROVED**  
For NPC-2 Compliance only  
*[Signature]*  
May 7, 2001  
Office of Statewide Health  
Planning and Development  
Facilities Development Division

FOR ATTACHMENT OF SLACK SUSPENSION WIRES TO STRUCTURE ABOVE, SEE SERIES "3.X" DETAILS. E.G. DETAIL **3.1**, **3.2**, **3.3**, ETC. AS APPLICABLE

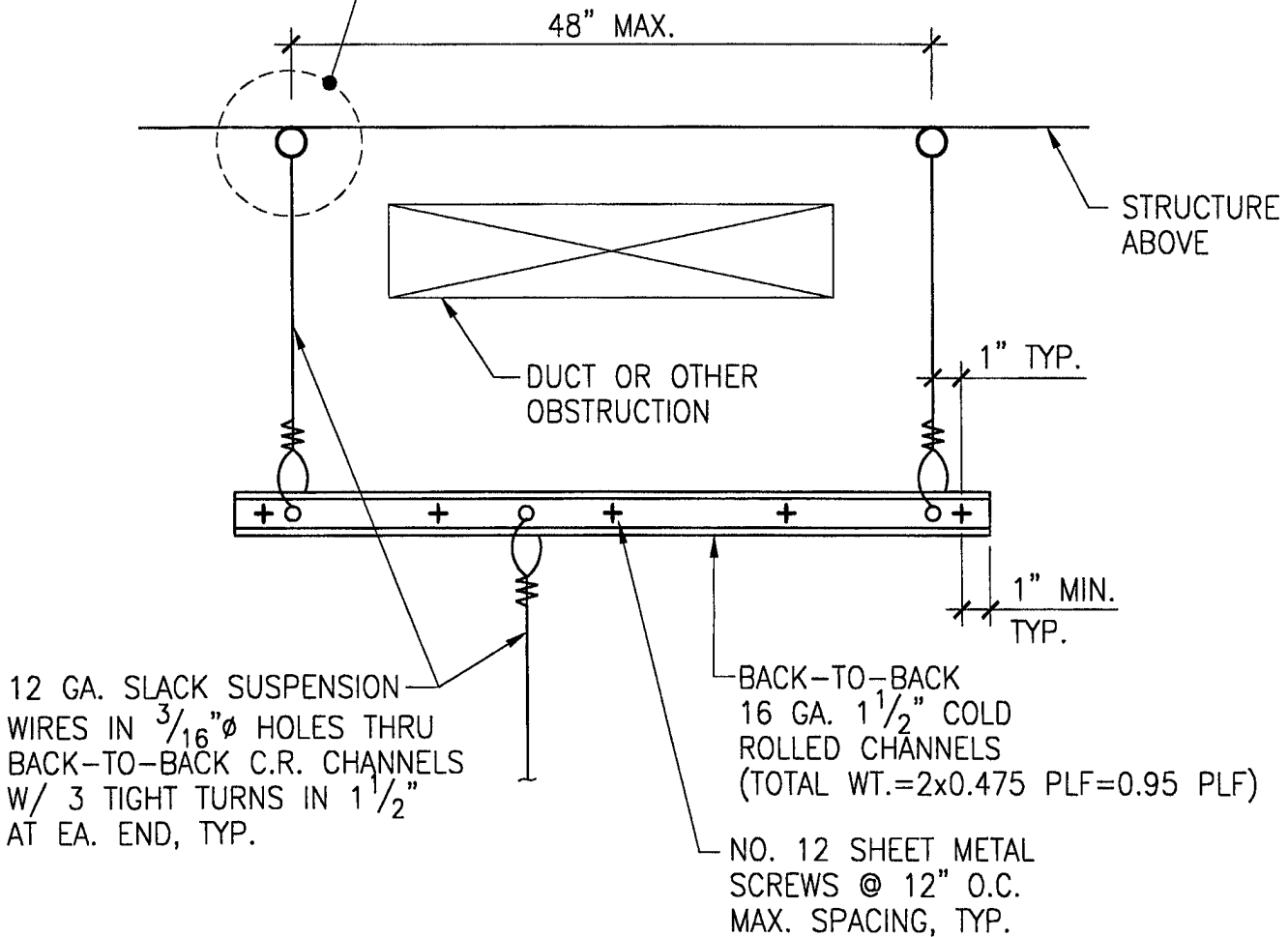

4.1

## ELEVATION - SPREADER BAR ASSEMBLY UP TO 4'-0" MAXIMUM SPAN

**APPROVED**  
For NPC-2 Compliance only  
*[Signature]*  
May 7, 2001  
Office of Statewide Health  
Planning and Development  
Facilities Development Division

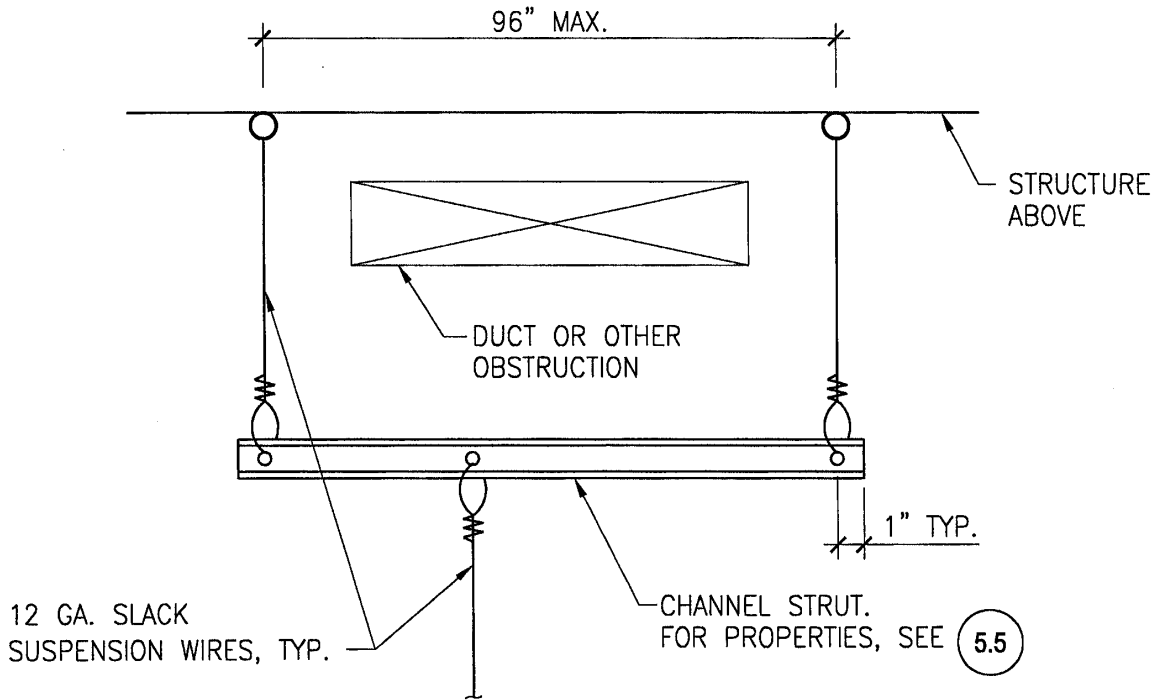

NOTE: FOR TYPICAL DETAILS NOT NOTED OR SHOWN, SEE DETAIL 4.1

4.2

## ELEVATION - CHANNEL STRUT SPREADER BAR UP TO 8'-0" MAXIMUM SPAN

**APPROVED**

For NPC-2 Compliance only

May 7, 2001

Office of Statewide Health  
Planning and Development  
Facilities Development Division

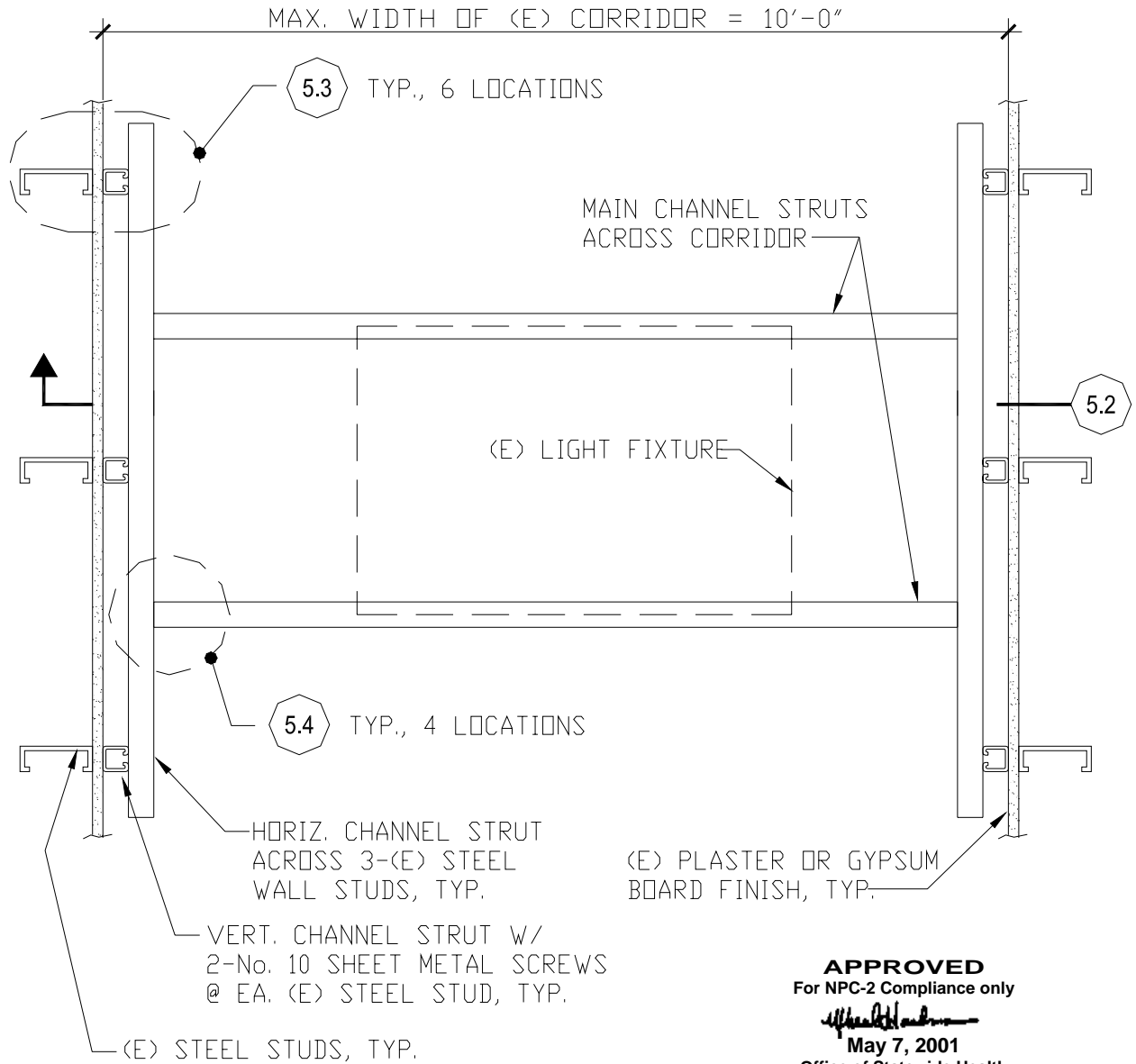

**APPROVED**  
For NPC-2 Compliance only  
*[Signature]*  
May 7, 2001  
Office of Statewide Health  
Planning and Development  
Facilities Development Division

NOTE: FOR PROPERTIES OF CHANNEL STRUTS, SEE 5.5

5.1 PLAN - CHANNEL STRUT BETWEEN  
(E) STEEL STUD CORRIDOR WALLS

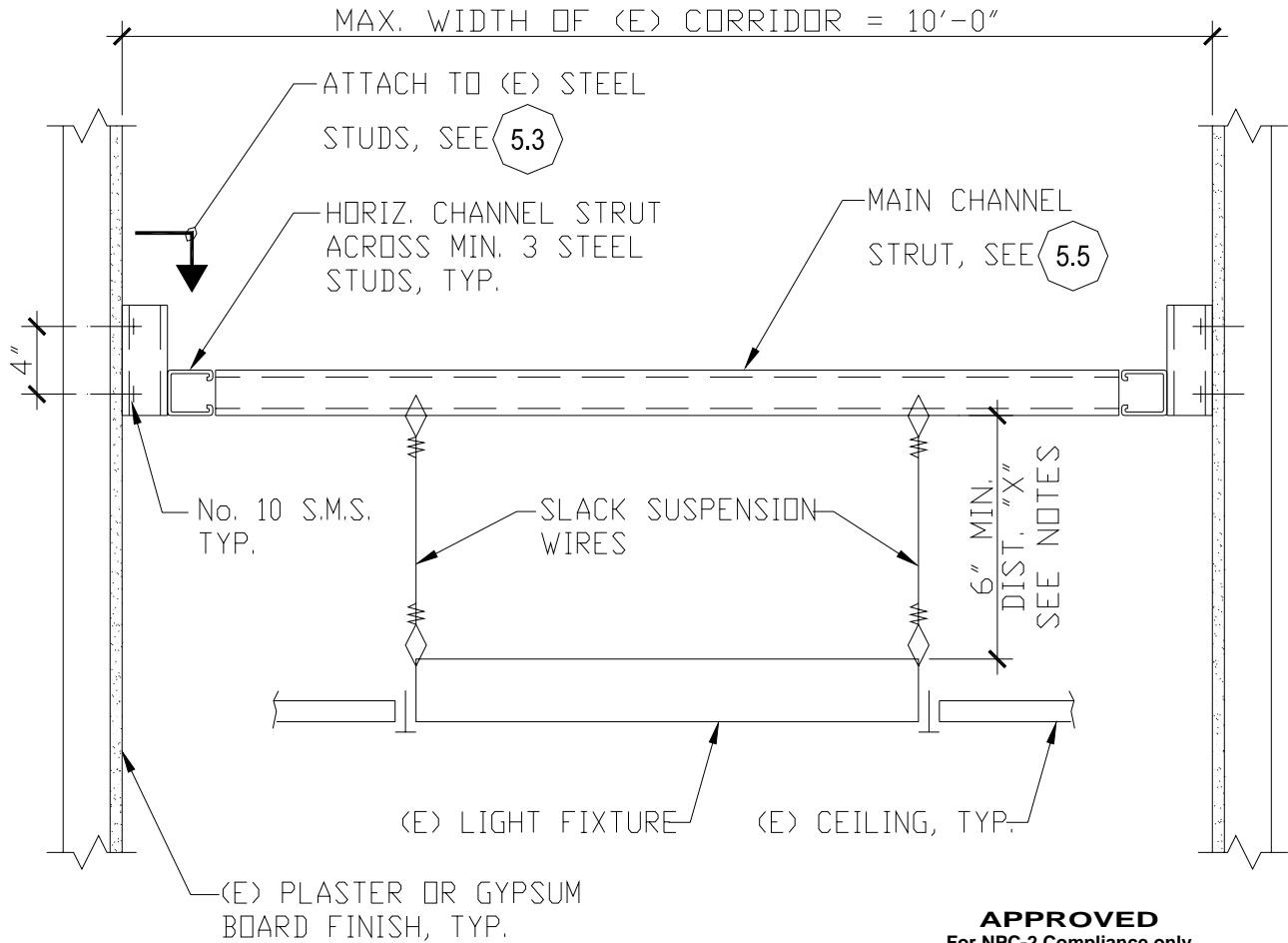

(E) STEEL STUDS.  
20 GA. MIN., TYP.

**APPROVED**  
For NPC-2 Compliance only

*[Signature]*  
May 7, 2001

Office of Statewide Health  
Planning and Development  
Facilities Development Division

**ELEVATION**

NOTES:

1. DISTANCE "X" MAY BE ZERO WHEN MAIN CHANNEL STRUT IS DIRECTLY MOUNTED TO (E) LIGHT FIXTURE WITH No. 10 SHEET METAL SCREWS AND WASHERS. WHEN CHANNEL STRUT IS DIRECTLY MOUNTED TO (E) LIGHT FIXTURE, SLACK SUSPENSION WIRES ARE NOT REQUIRED.
2. FOR 2'x4' OR SMALLER LIGHT FIXTURES, USE 2-SLACK SUSPENSION WIRES @ DIAGONALLY OPPOSITE CORNERS. FOR 4'x4' FIXTURES, USE 1-SLACK SUSPENSION WIRE @ EACH CORNER (TOTAL 4).

**5.2 CHANNEL STRUT BETWEEN (E) STEEL STUD CORRIDOR WALLS**



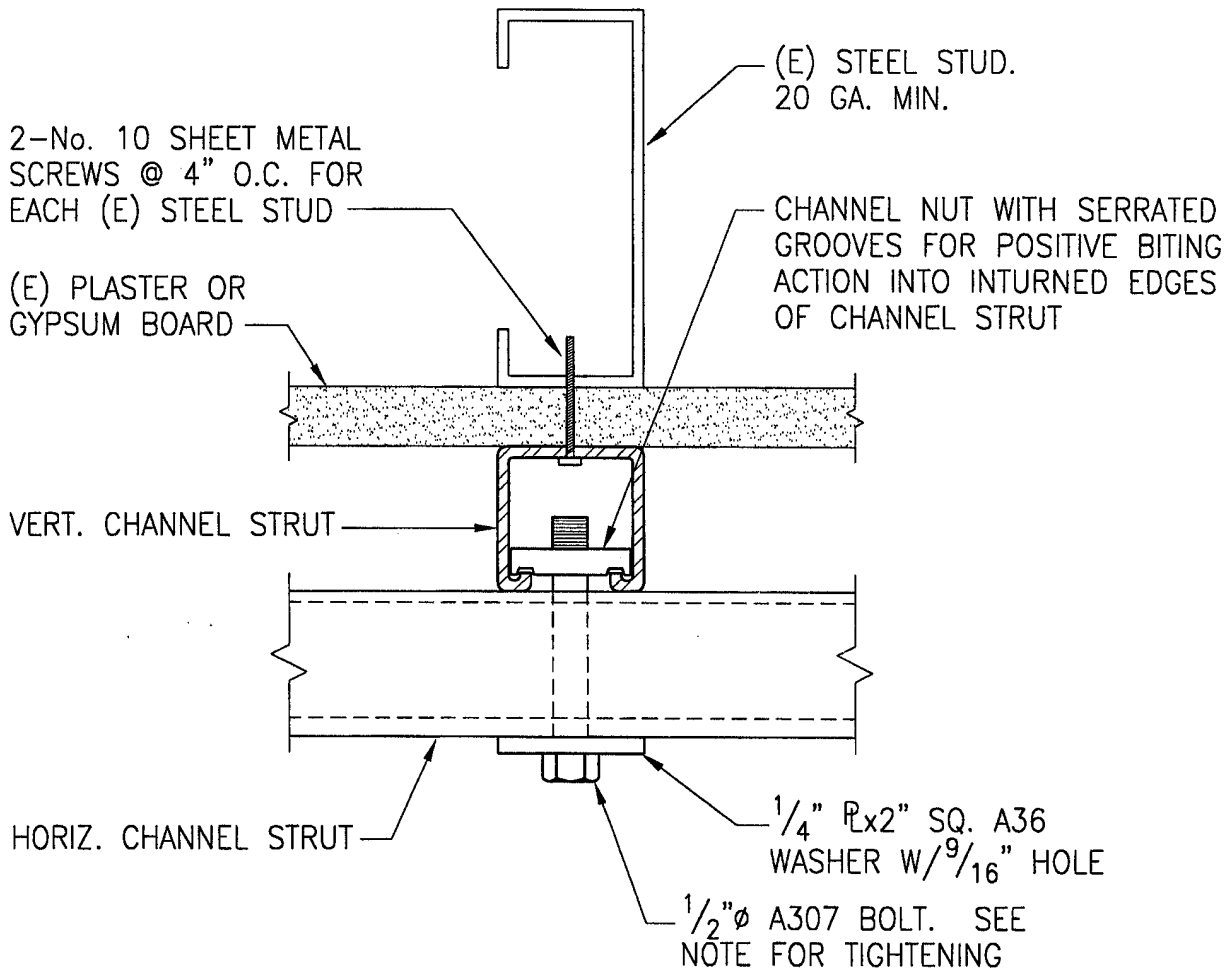

NOTE: TIGHTEN  $\frac{1}{2}$ " $\phi$  BOLT TO MIN. 50 FT-LBS TORQUE.

5.3

## PLAN DETAIL - CONNECTION TO (E) STEEL STUDS

**APPROVED**  
 For NPC-2 Compliance only  
  
 May 7, 2001  
 Office of Statewide Health  
 Planning and Development  
 Facilities Development Division

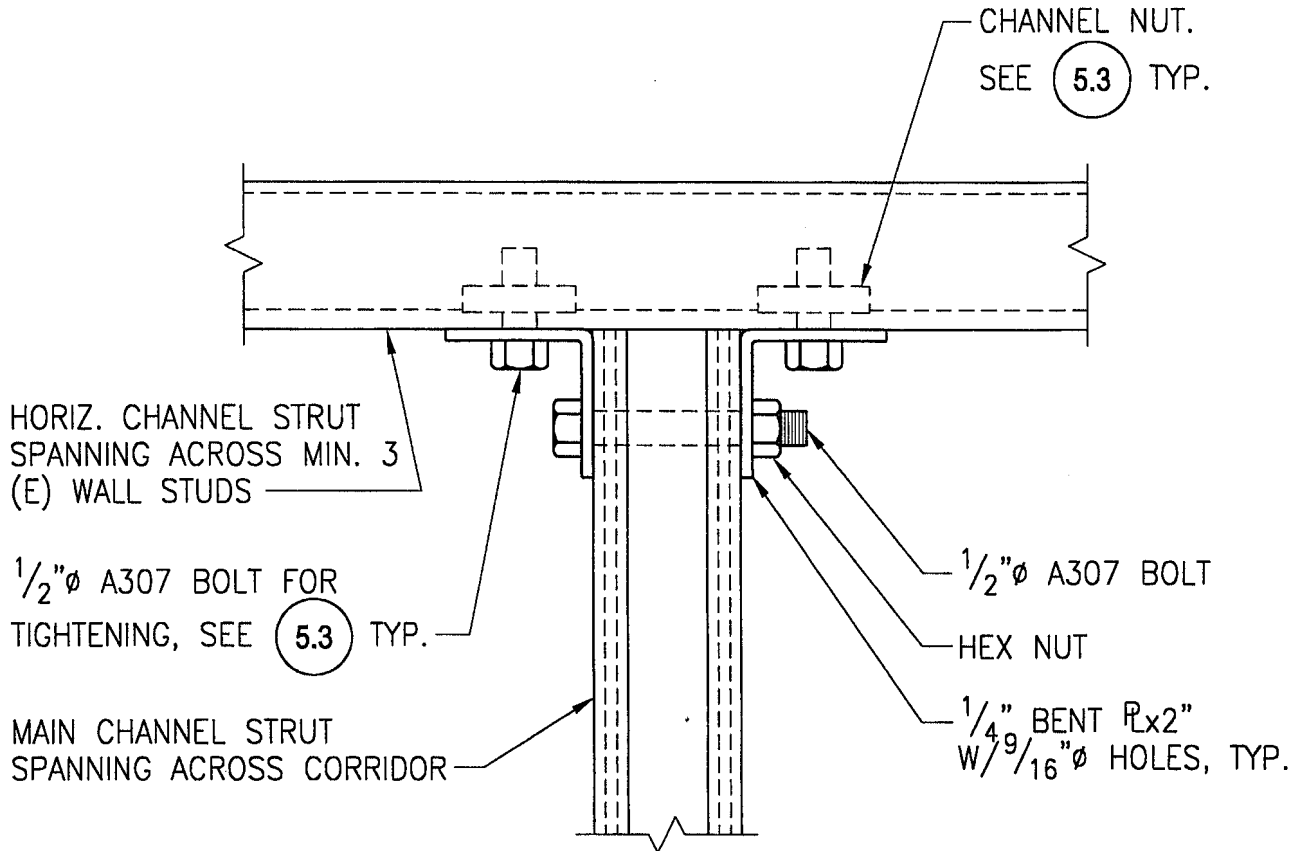

5.4

## PLAN DETAIL - 90° CONNECTION BETWEEN CHANNEL STRUTS

**APPROVED**  
For NPC-2 Compliance only  
*[Signature]*  
May 7, 2001  
Office of Statewide Health  
Planning and Development  
Facilities Development Division

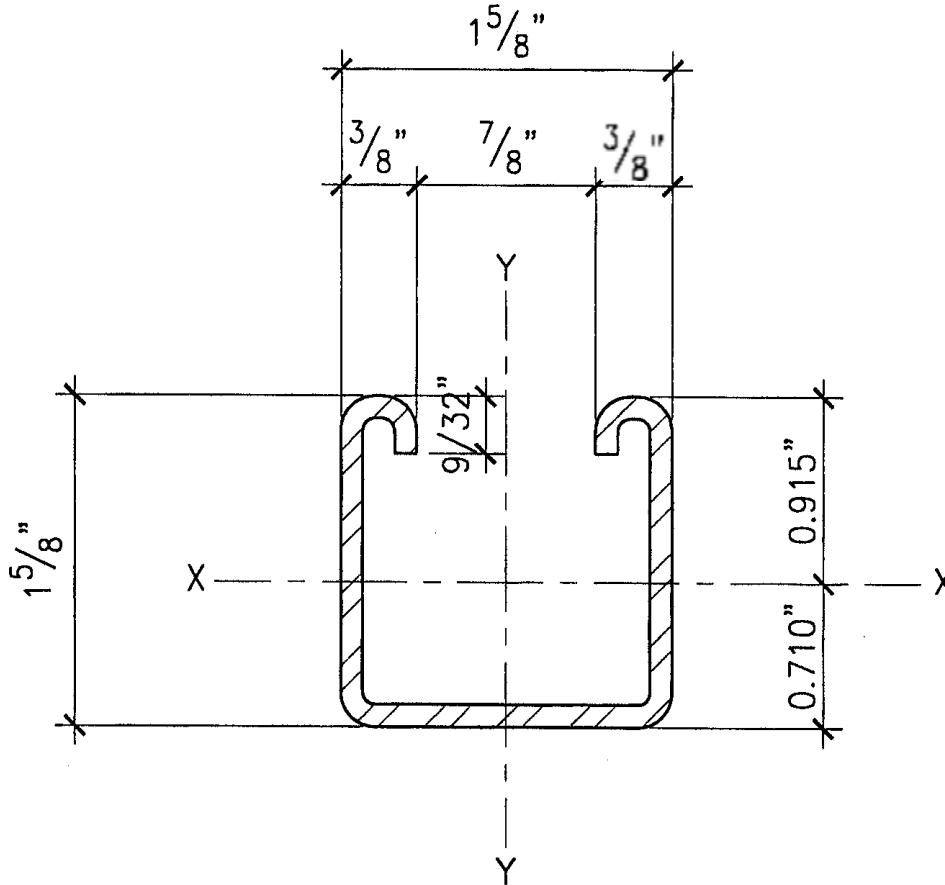

MATERIAL: 12 GA. COLD ROLLED STEEL PER ASTM A653 GR33

$$A = 0.556 \text{ IN}^2$$

$$I_x = 0.185 \text{ IN}^4 \quad I_y = 0.236 \text{ IN}^4$$

$$S_x = 0.202 \text{ IN}^3 \quad S_y = 0.290 \text{ IN}^3$$

PRE-GALVANIZED PER ASTM A653 G90

5.5

## TYPICAL CHANNEL STRUTS

**APPROVED**  
 For NPC-2 Compliance only  
  
 May 7, 2001  
 Office of Statewide Health  
 Planning and Development  
 Facilities Development Division