



OFFICE OF STATEWIDE HEALTH PLANNING AND DEVELOPMENT
FACILITIES DEVELOPMENT DIVISION

APPLICATION FOR OSHPD PREAPPROVAL
OF MANUFACTURER'S CERTIFICATION (OPM)

OFFICE USE ONLY

APPLICATION #: OPM-0275-13

OSHPD Preapproval of Manufacturer's Certification (OPM)

Type: New Renewal Update to Pre-CBC 2013 OPA Number: OPA-0275-13

Manufacturer Information

Manufacturer: Haworth® Inc

Manufacturer's Technical Representative: Jamison Burchfield

Mailing Address: One Haworth Center, Holland, MI 49423-9576

Telephone: 616-393-4227 Email: Jamison.Burchfield@Haworth.com

Product Information

Product Name: Wall Mount® Adaptable Overhead Storage

Product Type: Wall mounted storage cabinet

Product Model Number: Configurations for 14" deep by 16" high by 24" through 72" long

General Description: Overhead Wall Mounted Storage Cabinets

Applicant Information

Applicant Company Name: Haworth® Inc

Contact Person: Jamison Burchfield

Mailing Address: One Haworth Center, Holland, MI 49423-9576

Telephone: 616-393-4227 Email: Jamison.Burchfield@Haworth.com

I hereby agree to reimburse the Office of Statewide Health Planning and Development review fees in accordance with the California Administrative Code, 2016.

Signature of Applicant: *Jamison Burchfield* Date: 08.08.18

Title: Senior Sales Engineer Company Name: Haworth Inc.

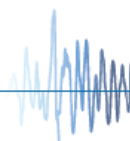



**OFFICE OF STATEWIDE HEALTH PLANNING AND DEVELOPMENT
FACILITIES DEVELOPMENT DIVISION**

Registered Design Professional Preparing Engineering Recommendations

Company Name: CYS Structural Engineers, Inc.

Name: Dieter T. Siebald California License Number: S4346

Mailing Address: 2495 Natomas Park Drive, Sacramento, CA 95833

Telephone: 916-920-2020 Email: dieters@cyseng.com

OSHPD Special Seismic Certification Preapproval (OSP)

- Special Seismic Certification is preapproved under OSP-
(Separate application for OSP is required)
- Special Seismic Certification is not preapproved

Certification Method(s)

- Testing in accordance with: ICC-ES AC156 FM 1950-16
- Other* (Please Specify): _____

*Use of criteria other than those adopted by the California Building Standards Code, 2016 (CBSC 2016) for component supports and attachments are not permitted. For distribution system, interior partition wall, and suspended ceiling seismic bracings, test criteria other than those adopted in the CBSC 2016 may be used when approved by OSHPD prior to testing.

- Analysis
- Experience Data
- Combination of Testing, Analysis, and/or Experience Data (Please Specify): _____

List of Attachments Supporting the Manufacturer's Certification

- Test Report Drawings Calculations Manufacturer's Catalog
- Other(s) (Please Specify): _____

OFFICE USE ONLY – OSHPD APPROVAL VALID FOR CBC 2016 & ALL PRE-2016 CODE BASED PROJECTS

Signature:  Date: November 15, 2018

Print Name: Jeffrey Kikumoto

Title: SSE

Condition of Approval (if applicable): _____

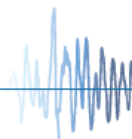
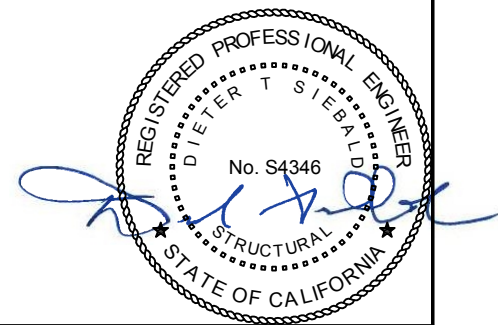

TABLE OF CONTENTS
OPM-0275-13

	PAGE
GENERAL NOTES	2
ABBREVIATIONS	3
SYSTEM OVERVIEW & DESIGN CRITERIA	3
OVERHEAD CABINET ATTACHMENT SCHEDULE	4
LOAD BAR DETAIL	5-6
OVERHEAD CABINET ATTACHMENT TO STEEL STUD WALL	7

- NOTES:**
1. THESE DRAWINGS ARE PREPARED FOR HAWORTH, INC.
 2. THE CONTRACTOR AND INSPECTOR OF RECORD SHALL OBTAIN A COPY OF THIS PRE-APPROVAL FROM THE OFFICE OF STATEWIDE HEALTH PLANNING & DEVELOPMENT (OSHPD) PRE-APPROVAL PROGRAMS WEBSITE.
 3. THIS PRE-APPROVAL COVERS THE SUPPORTS AND ATTACHMENTS OF THE WALL MOUNT ADAPTABLE OVERHEAD STORAGE TO THE SUPPORTING STRUCTURE. THE OVERHEAD STORAGE CABINETS, WALL MOUNTING LOAD BARS & FASTENER KITS ARE SUPPLIED BY HAWORTH.



SHEET TITLE: TABLE OF CONTENTS



CYS STRUCTURAL ENGINEERS, INC.

2495 NATOMAS PARK DRIVE, SUITE 650
SACRAMENTO, CA 95833

TEL (916) 920-2020
www.cyseng.com

Job No:	17146
Date:	08/08/2018
Page:	1 of 7

GENERAL NOTES:

1. THIS OSHPD PRE-APPROVAL OF MANUFACTURER'S CERTIFICATION (OPM) IS BASED ON THE CBC 2016. THE DEMAND (DESIGN FORCES) FOR USE W/ THIS OPM SHALL BE BASED ON THE CBC 2016.
2. IT IS THE RESPONSIBILITY OF THE STRUCTURAL ENGINEER OF RECORD (SEOR) FOR A SITE SPECIFIC PROJECT TO VERIFY:
 - A. THE ADEQUACY OF THE NEW OR EXISTING STRUCTURE (METAL STUDS, ETC.) TO RESIST THE FORCES & WEIGHT SPECIFIED FOR EA COMPONENT IN ADDITION TO ALL OTHER LOADS. PROVIDE & DESIGN SUPPLEMENTARY MEMBERS & THEIR ATTACHMENTS AS REQ.
 - B. THE WALL FASTENERS ARE LOCATED AT A STUD WALL OF MIN SPECIFIED MATERIAL & GAUGE AS NOTED ON PGS 6 & 7.
 - C. THE INSTALLATION IS IN CONFORMANCE W/ THE CBC 2016 & W/ THE DETAILS SHOWN IN THIS PRE-APPROVAL.
 - D. THE COMPONENT'S ACTUAL WT, CENTER OF GRAVITY (CG) LOCATION, ATTACHMENT LOCATIONS, & THE DETAILS, MATERIAL & GAUGE OF THE COMPONENT WHERE ATTACHMENTS ARE MADE AGREE W/ THE INFORMATION SHOWN IN THE PRE-APPROVAL.
 - E. THE SHEET METAL SCREWS (SMS) ARE IN COMPLIANCE W/ "SSMA" STANDARDS, HAVE MIN LOAD CAPACITIES PER OPD-0001-13, SATISFY ICC-ES-AC118 & COMPLY W/ ESR-1271. REISSUED JULY 2018, OR EQ.
3. ALL COLD-FORMED STEEL FOR WALL STUDS SHALL CONFORM TO THE FOLLOWING, UNO. ASTM A653 STRUCTURAL QUALITY, GRADE 33 (18 GA) OR GRADE 50 (16 GA & HEAVIER)
4. TWO (2) CASES OF ATTACHMENT ARE SPECIFIED & PRESENTED IN THIS PRE-APPROVAL:

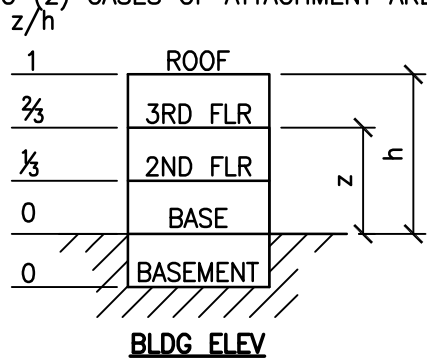

CASE 1: SUPPORT & ATTACHMENT LOCATED AT ANY LEVEL IN A BLDG ($z/h \leq 1.0$).

5. THIS PRE-APPROVAL MAY BE USED AT ANY GEOGRAPHICAL LOCATION IN THE STATE OF CALIFORNIA WHERE S_{DS} IS LESS THAN OR EQ TO 2.50.

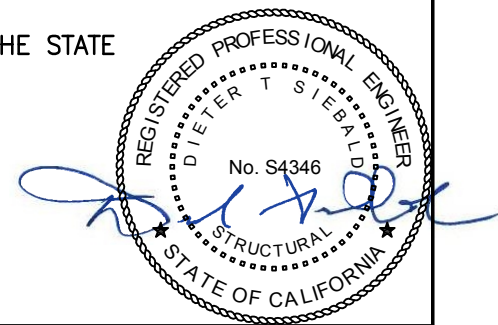

SHEET TITLE: GENERAL NOTES



CYS STRUCTURAL ENGINEERS, INC.

2495 NATOMAS PARK DRIVE, SUITE 650
SACRAMENTO, CA 95833

TEL (916) 920-2020
www.cyseng.com

Job No:	17146
Date:	08/08/2018
Page:	2 of 7

ABBREVIATIONS:

ADDNL	ADDITIONAL	F_p	HORIZONTAL SEISMIC FORCE PER ASCE 7-10 SEISMIC FORCE REQUIREMENTS	PG(S)	PAGE(S)
ASD	ALLOWABLE STRESS DESIGN			R_L	PLATE
ASTM	AMERICAN SOCIETY FOR TESTING & MATERIALS	F_y	SPECIFIED MINIMUM YIELD STRESS OF STEEL	REQ	REQUIRED
BLDG	BUILDING			SEOR	STRUCTURAL ENGINEER OF RECORD
BLW	BELOW	GA	GAUGE	SMS	SHEET METAL SCREW
CBC	CALIFORNIA BUILDING CODE	GWB	GYPSON WALLBOARD	STL	STEEL
CG	CENTER OF GRAVITY	ICC	INTERNATIONAL CODE COUNCIL	T_{max}	MAXIMUM TENSION REACTION
\bar{C}	CENTERLINE	IN (")	INCH	TYP	TYPICAL
DIA (ϕ)	DIAMETER	KSI	KIPS PER SQUARE INCH	T&B	TOP & BOTTOM
(E)	EXISTING CONDITION	LBS	POUNDS	UNO	UNLESS NOTED OTHERWISE
EA	EACH	LGTH	LENGTH	V_{max}	MAXIMUM SHEAR REACTION
EE	EACH END	LRFD	LOAD AND RESISTANCE FACTOR DESIGN	W/	WITH
ELEV	ELEVATION	MAX	MAXIMUM	W_p	OPERATING WEIGHT
ES	EA SIDE	MFR	MANUFACTURER	WT	WEIGHT
EQ	EQUAL	MIN	MINIMUM		
FLG	FLANGE	NO. (#)	NUMBER OR POUNDS		
FLR	FLOOR				

SYSTEM OVERVIEW & DESIGN CRITERIA

- THE WALL MOUNT ADAPTABLE OVERHEAD STORAGE IS AN OVERHEAD CABINET 14" DEEP, 16" HIGH & 24" TO 72" WIDE (AVAILABLE IN 6" INCREMENTS). THE OPERATING WT FOR THE CABINET IS BASED ON COMPONENT WT (5 PCF) PLUS WT OF MEDIA AS FOLLOWS:
PAPER MEDIA: 33 PCF PER TOTAL USEABLE STORAGE VOLUME OF THE CABINET (12" DEEP x 12" HIGH)
- ATTACHMENT DESIGN IS PER 2016 CBC AT ASD LEVEL FORCES.

CABINETS & OTHER RIGID COMPONENTS W/ LIMITED DEFORMABILITY ELEMENTS & ATTACHMENTS PER TABLE 13.5-1 OF ASCE 7-10 SUPPLEMENT #1:

$$\alpha_p = 1.0 \quad R_p = 2.5 \quad I_p = 1.5$$

W_p AS NOTED ON DRAWINGS SHOWN ON PG 4.

ANY LOCATION IN THE BLDG WHERE $z/h \leq 1$
CASE 1: $S_{DS} = 2.50 \quad F_p = 1.80 W_p$

ASD GOVERNING LOAD COMBINATION
(1.0 + 0.7*0.2 S_{DS}) D + 0.7 F_p

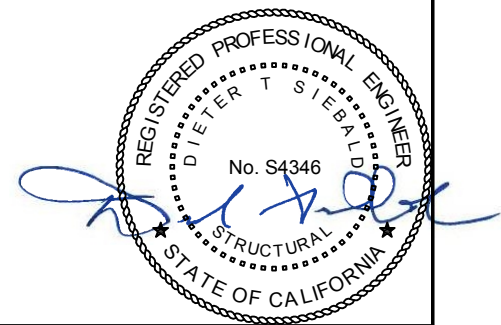

SHEET TITLE: ABBREVIATIONS
SYSTEM OVERVIEW & DESIGN CRITERIA



CYS STRUCTURAL ENGINEERS, INC.

2495 NATOMAS PARK DRIVE, SUITE 650
SACRAMENTO, CA 95833

TEL (916) 920-2020
www.cyseng.com

Job No:	17146
Date:	08/08/2018
Page:	3 of 7

OVERHEAD CABINET ATTACHMENT SCHEDULE

CABINET WIDTH (IN)	24	30	36	42	48	54	60	66	72	
MAX CG WT, W_p (LBS) ⁽¹⁾	89	111	133	156	178	200	222	244	266	
NO. OF SMS PER STUD AT LOAD BAR	2- #12			3- #12						
STUDS SPACED 12" OC										
MIN NO. OF STUDS FOR ATTACHMENT	2	2	3	3	4	4	4	5	6	
MAX ASD FORCES PER SCREW (LBS)	T_{max}	47	59	42	40	32	36	40	34	30
	V_{max}	39	47	74	68	62	81	88	57	77
STUDS SPACED 16" OC										
MIN NO. OF STUDS FOR ATTACHMENT	2	2	2	3	3	3	4	4	4	
MAX ASD FORCES PER SCREW (LBS)	T_{max}	42	52	63	35	40	45	37	40	44
	V_{max}	30	48	46	46	52	76	68	84	90
STUDS SPACED 24" OC										
MIN NO. OF STUDS FOR ATTACHMENT	N/A	2	2	2	2	3	3	3	3	
MAX ASD FORCES PER SCREW (LBS)	T_{max}	-	50	60	52	59	43	47	52	57
	V_{max}	-	32	47	36	44	43	60	74	83

(1) INCLUDES CABINET WT + CONTENT

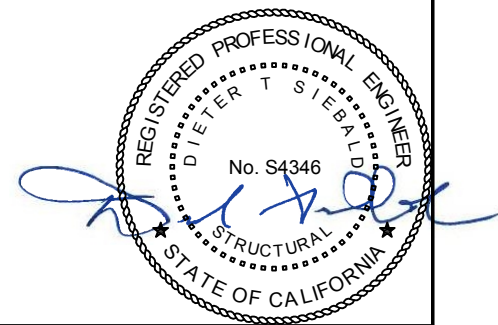

SHEET TITLE: OVERHEAD CABINET ATTACHMENT SCHEDULE



CYS STRUCTURAL ENGINEERS, INC.

2495 NATOMAS PARK DRIVE, SUITE 650
SACRAMENTO, CA 95833

TEL (916) 920-2020
www.cyseng.com

Job No:	17146
Date:	08/08/2018
Page:	4 of 7

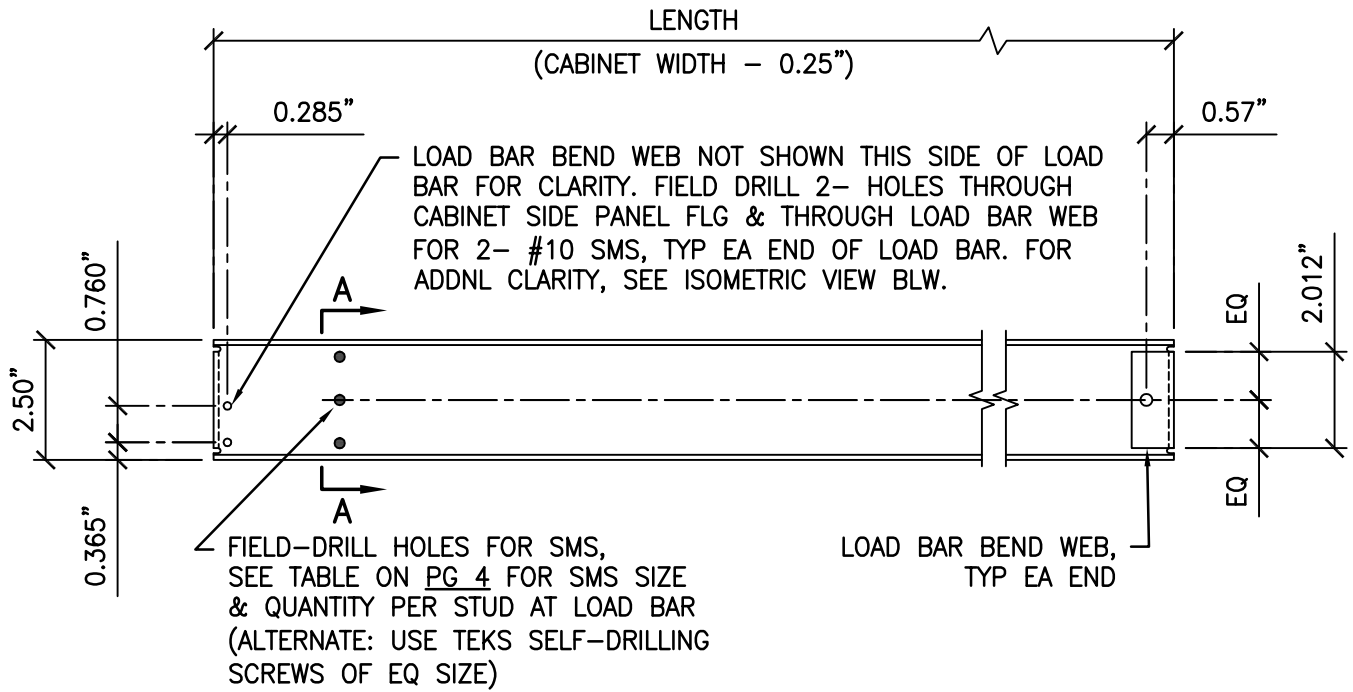

LOAD BAR ELEV

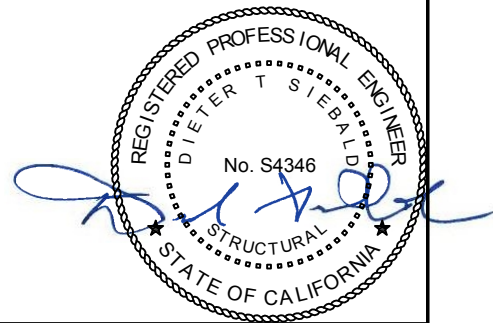
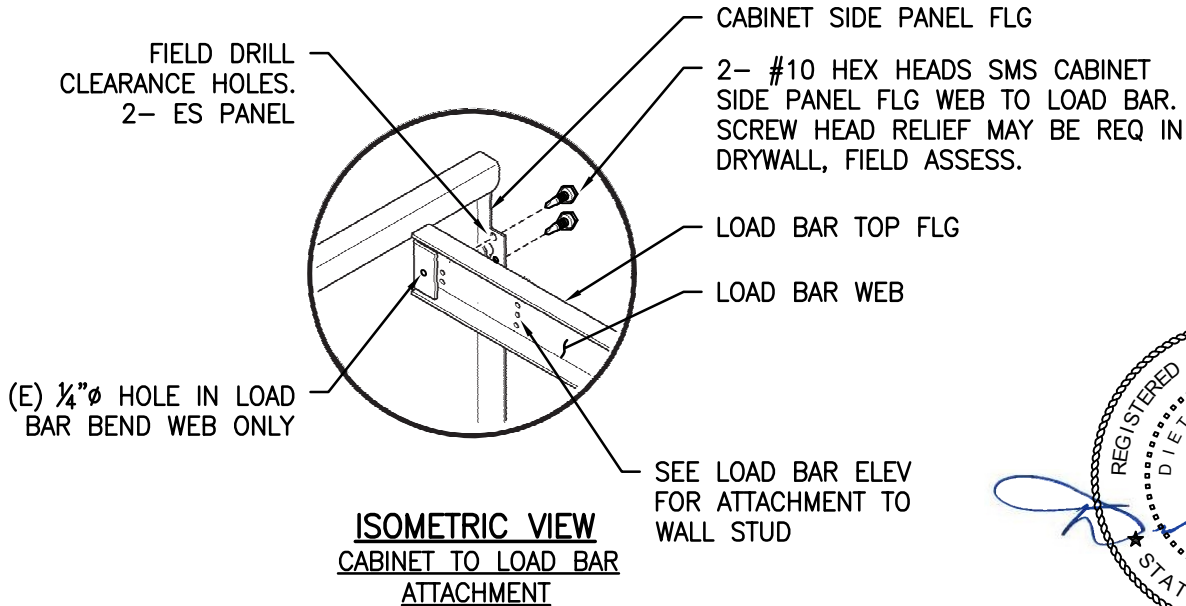

SHEET TITLE: LOAD BAR DETAIL



CYS STRUCTURAL ENGINEERS, INC.

2495 NATOMAS PARK DRIVE, SUITE 650
SACRAMENTO, CA 95833

TEL (916) 920-2020
www.cyseng.com

Job No:	17146
Date:	08/08/2018
Page:	5 of 7

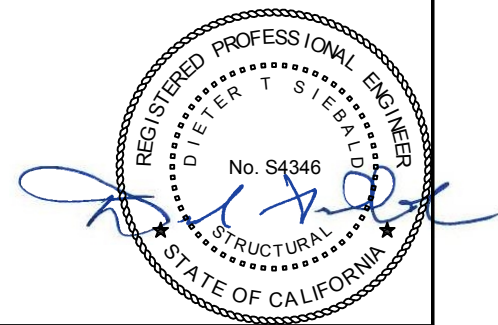
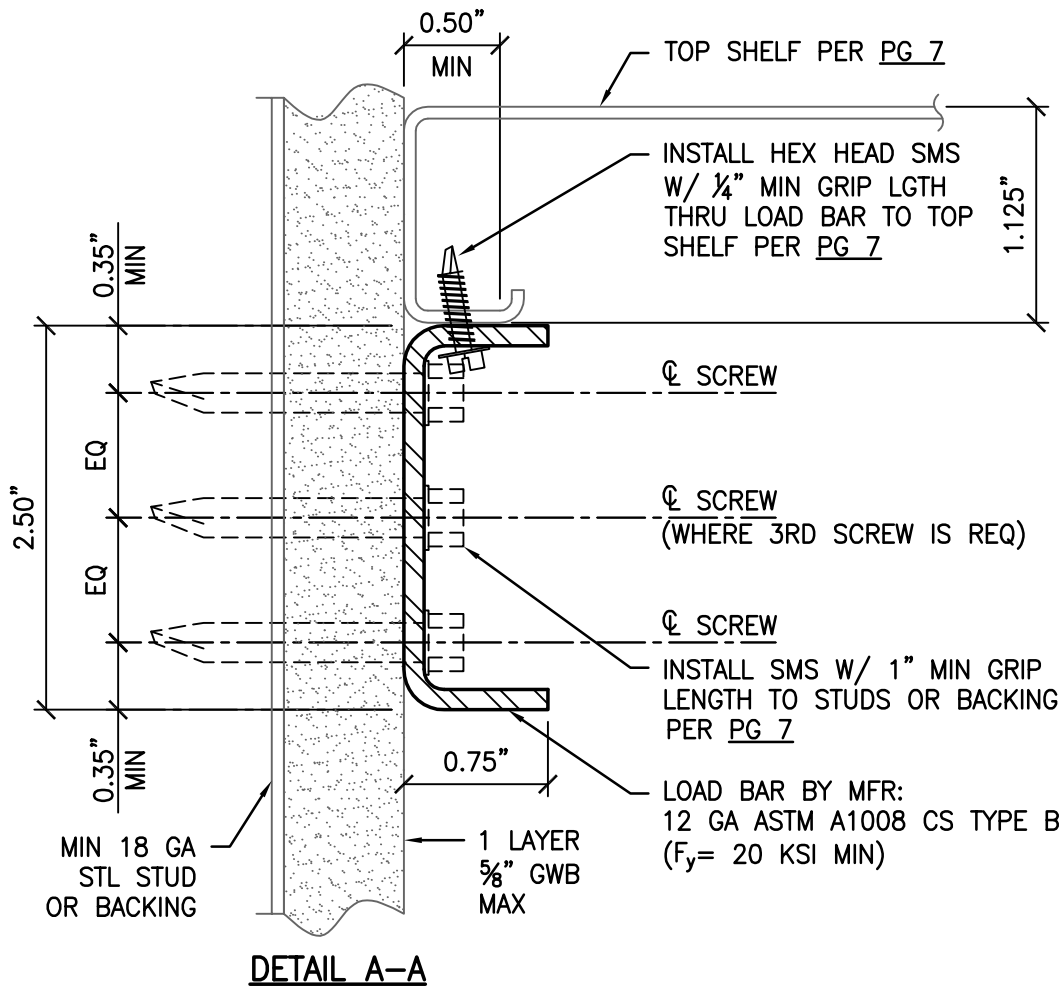

SHEET TITLE: LOAD BAR DETAIL



CYS STRUCTURAL ENGINEERS, INC.

2495 NATOMAS PARK DRIVE, SUITE 650
SACRAMENTO, CA 95833

TEL (916) 920-2020
www.cyseng.com

Job No:	17146
Date:	08/08/2018
Page:	6 of 7

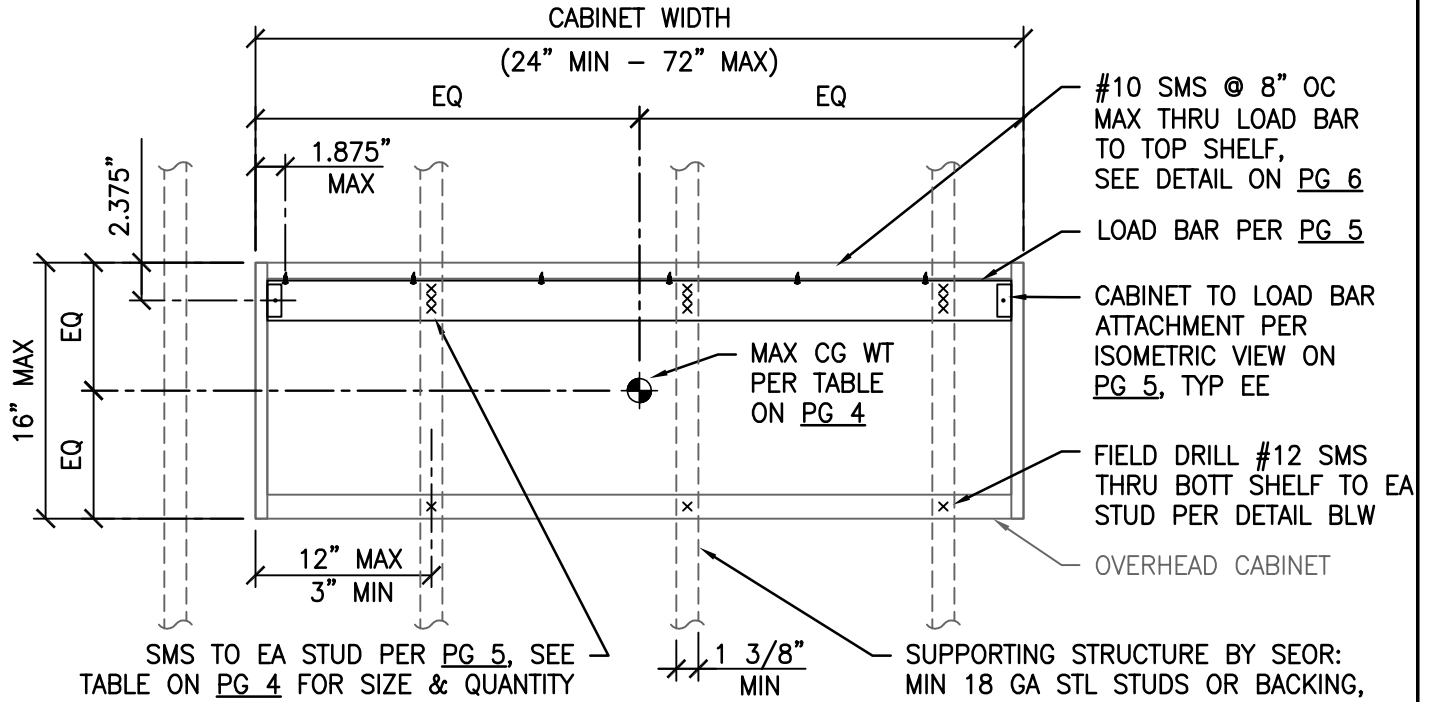

FRONT ELEV

14" MAX
SEE NOTE 1. PAGE 3

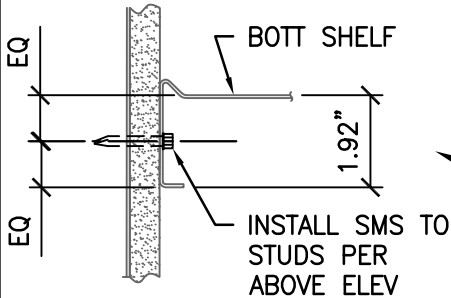

DETAIL

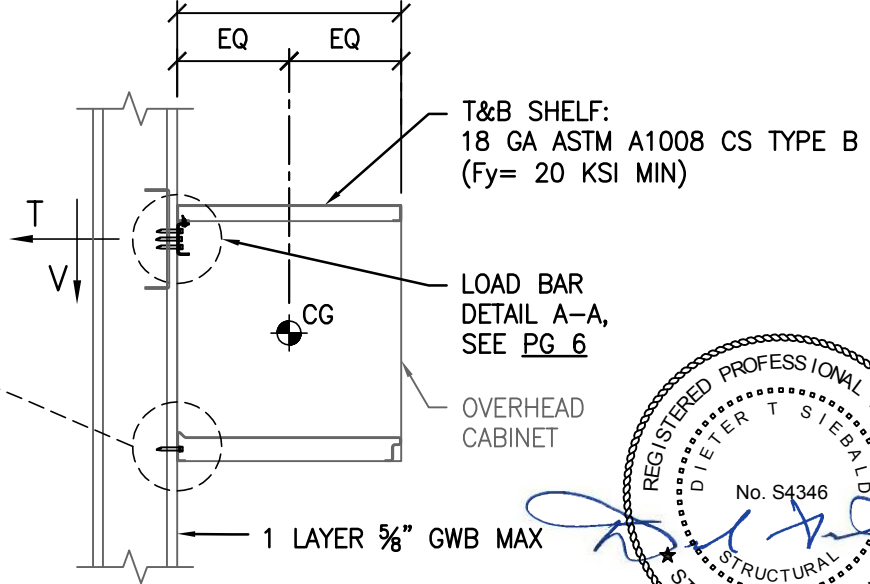

SECTION

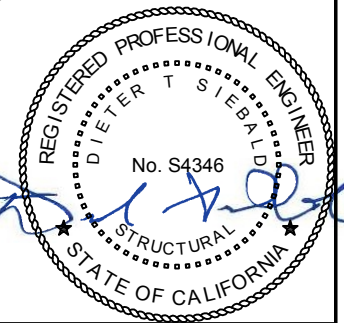

SHEET TITLE: OVERHEAD CABINET ATTACHMENT TO STEEL STUD WALL



CYS STRUCTURAL ENGINEERS, INC.

2495 NATOMAS PARK DRIVE, SUITE 650
SACRAMENTO, CA 95833

TEL (916) 920-2020
www.cyseng.com

Job No:	17146
Date:	08/08/2018
Page:	7 of 7