



**OFFICE OF STATEWIDE HEALTH PLANNING AND DEVELOPMENT  
FACILITIES DEVELOPMENT DIVISION**

**APPLICATION FOR OSHPD PREAPPROVAL OF  
MANUFACTURER'S CERTIFICATION (OPM)**

OFFICE USE ONLY

APPLICATION #: OPM-0488-13

**OSHPD Preapproval of Manufacturer's Certification (OPM)**

Type:  New  Renewal  Update to Pre-CBC 2013 OPA Number: \_\_\_\_\_

**Manufacturer Information**

Manufacturer: Olea Kiosks

Manufacturer's Technical Representative: Tim Ruwe

Mailing Address: 13845 Artesia Blvd, Cerritos, CA 90703

Telephone: (562) 924-2644 Email: tim@olea.com

**Product Information**

Product Name: Kaiser Gen3 Kiosk

Product Type: Other Electrical & Mechanical Components

Product Model Number: KAI03

General Description: Electronic Check-In Kiosk

**Applicant Information**

Applicant Company Name: KPFF Consulting Engineers

Contact Person: William Thorpe

Mailing Address: 18400 Von Karman Avenue, Suite 600, Irvine, CA 92612

Telephone: (949) 252-1022 Email: Bill.Thorpe@kpff.com

I hereby agree to reimburse the Office of Statewide Health Planning and Development review fees in accordance with the California Administrative Code, 2016.

Signature of Applicant:  Date: 4/27/2018

Title: Principal Engineer Company Name: KPFF Consulting Engineers

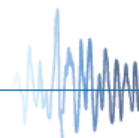



**OFFICE OF STATEWIDE HEALTH PLANNING AND DEVELOPMENT  
FACILITIES DEVELOPMENT DIVISION**

**Registered Design Professional Preparing Engineering Recommendations**

Company Name: KPFF Consulting Engineers

Name: William Thorpe California License Number: S3866

Mailing Address: 18400 Von Karman Avenue, Suite 600, Irvine, CA 92612

Telephone: (949) 252-1022 Email: Bill.Thorpe@kpff.com

**OSHPD Special Seismic Certification Preapproval (OSP)**

- Special Seismic Certification is preapproved under OSP-  
(Separate application for OSP is required)
- Special Seismic Certification is not preapproved

**Certification Method(s)**

- Testing in accordance with:  ICC-ES AC156  FM 1950-16
- Other\* (Please Specify): \_\_\_\_\_

\*Use of criteria other than those adopted by the California Building Standards Code, 2016 (CBSC 2016) for component supports and attachments are not permitted. For distribution system, interior partition wall, and suspended ceiling seismic bracings, test criteria other than those adopted in the CBSC 2016 may be used when approved by OSHPD prior to testing.

- Analysis
- Experience Data
- Combination of Testing, Analysis, and/or Experience Data (Please Specify): \_\_\_\_\_

**List of Attachments Supporting the Manufacturer's Certification**

- Test Report  Drawings  Calculations  Manufacturer's Catalog
- Other(s) (Please Specify): \_\_\_\_\_

**OFFICE USE ONLY – OSHPD APPROVAL VALID FOR CBC 2016 & ALL PRE-2016 CODE BASED PROJECTS**

Signature: \_\_\_\_\_ Date: November 09, 2018

Print Name: Jeffrey Kikumoto

Title: SSE

Condition of Approval (if applicable): \_\_\_\_\_

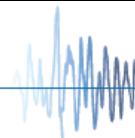



18400 Von Karman Ave.,  
Suite 600  
Irvine, CA 92612  
O: 949.252.1022  
F: 949.252.8082  
[www.kpff.com](http://www.kpff.com)

OLEA KIOSK OPM

BY: GN

SHEET NO.

-

DATE: 11-09-18

1

-

CHECKED: RG

JOB NO.

GENERAL NOTES

1800184

Office of Statewide Health Planning and Development  
PREAPPROVAL OF MANUFACTURER'S CERTIFICATION

# OPM - 0488-13

THE PREAPPROVAL CONFORMS TO THE 2016 CALIFORNIA BUILDING CODE

MANUFACTURER: **OLEA KIOSKS**  
EQUIPMENT NAME: **KAISER GEN3 KIOSK, MODEL No. KA103**

## GENERAL NOTES

1. THIS OSHPD PREAPPROVAL OF MANUFACTURER'S CERTIFICATION (OPM) IS BASED ON THE 2016 CBC (CALIFORNIA BUILDING CODE). THE DEMANDS (DESIGN FORCES) FOR USE WITH THIS OPM SHALL BE BASED ON THE 2016 CBC.
2. THIS DOCUMENT MAY ONLY BE USED WITH THE EXPRESS WRITTEN CONSENT OF THE MANUFACTURER LISTED ABOVE FOR THE SPECIFIC PROJECT SITE AND INSTALLATION LOCATION. THIS DOCUMENT IS INVALID WITHOUT SUCH CONSENT.
3. THIS PREAPPROVAL CONFORMS TO THE 2016 CBC WHERE  $S_{DS}$  IS NOT GREATER THAN 1.93 AND 1.37. SEE DETAIL FOR APPLICABILITY.
4. FORCES PER ASCE 7-10 SECTION 13.3.1, EQUATIONS 13.3-1, 13.3-2 & 13.3-3,  
WHERE  $S_{DS} = 1.93$ ,  $a_p = 1.0$ ,  $I_p = 1.5$ ,  $R_p = 1.5$ ,  $z/h \leq 1$ ,  $\Omega_o = 1.5$  AT CONCRETE SLAB.  
WHERE  $S_{DS} = 1.93$ ,  $a_p = 1.0$ ,  $I_p = 1.5$ ,  $R_p = 1.5$ ,  $z/h \leq 1$ ,  $\Omega_o = 1.5$  AT CONCRETE SLAB ON METAL DECK.  
WHERE  $S_{DS} = 1.37$ ,  $a_p = 1.0$ ,  $I_p = 1.5$ ,  $R_p = 1.5$ ,  $z/h \leq 1$ ,  $\Omega_o = 1.5$  AT CONCRETE SLAB ON METAL DECK.
5. THIS PREAPPROVAL COVERS ONLY THE SUPPORTS AND ATTACHMENTS OF THE EQUIPMENT TO THE STRUCTURE.
6. ALL DESIGN FORCES SHOWN ON THE DRAWINGS ARE FACTORED LOADS THAT SHALL BE USED FOR STRENGTH DESIGN.

## RESPONSIBILITIES OF THE STRUCTURAL ENGINEER OF RECORD OF THE BUILDING

1. PROVIDE SUPPORTING STRUCTURE TO SUPPORT WEIGHTS AND FORCES SHOWN IN ADDITION TO ALL OTHER LOADS.
2. VERIFY THAT THE INSTALLATION IS IN CONFORMANCE WITH THE 2016 CBC AND WITH THE DETAILS. MATERIAL AND GAGE OF THE UNIT WHERE ATTACHMENTS ARE MADE AGREE WITH INFORMATION SHOWN ON THE PREAPPROVAL DOCUMENTS.
3. VERIFY THAT PROJECT SPECIFIC VALUES  $S_{DS}$  &  $z/h$  RESULT IN SEISMIC FORCES ( $E_h$ ,  $E_v$ ) THAT DO NOT EXCEED THE VALUES OF THE DETAILS.
4. VERIFY THAT THE CONCRETE SLAB TO WHICH THE EQUIPMENT IS ANCHORED MEETS THE REQUIREMENTS OF THE APPLICABLE ICC ESR.
5. VERIFY THAT THE ANCHORS ARE AN ADEQUATE DISTANCE FROM ANY SLAB EDGES OR OPENINGS (SEE TYPICAL DETAIL ON SHEET 2).
6. VERIFY THAT ALL NEW OR EXISTING ANCHORS ARE AN ADEQUATE DISTANCE FROM THE UNIT ATTACHEMNTS AND CHECK FOR INTERACTION WHERE OTHER ANCHORS ARE WITHIN 18" OR  $6h_{ef}$  FROM THIS UNIT'S ANCHORS.





18400 Von Karman Ave.,  
Suite 600  
Irvine, CA 92612  
O: 949.252.1022  
F: 949.252.8082  
[www.kpff.com](http://www.kpff.com)

OLEA KIOSK OPM

BY: GN

SHEET NO.

-

DATE: 11-09-18

2

-

CHECKED: RG

JOB NO.

GENERAL NOTES

1800184

EXPANSION ANCHORS:

- ATTACHMENT IS TO BE MADE WITH THE ANCHORS LISTED BELOW AND INSTALLED AS DESCRIBED IN THE CORRESPONDING ICC REPORT

ANCHOR DIAMETER	CONCRETE TYPE	MIN. f'c (psi)	ANCHOR TYPE	ICC REPORT #	MIN EMBED.	MIN SPACING	MIN EDGE DISTANCE	MIN CONC THICKNESS	TORQUE TEST
1/2"	SAND LIGHT WEIGHT	3000	HILTI KWIK BOLT TZ	ESR-1917	2"	7.94"	24"	3 1/4" OVER DECK	40 FT-LB
1/2"	NORMAL WEIGHT	3000	HILTI KWIK BOLT TZ	ESR-1917	2"	7.94"	24"	4"	40 FT-LB
3/8"	SAND LIGHT WEIGHT	3000	HILTI KWIK BOLT TZ	ESR-1917	2"	6.75"	12"	3 1/4" OVER DECK	25 FT-LB

- THIS PREAPPROVAL ALLOWS FOR UP TO A MAXIMUM OF 2 ADJACENT CONCRETE SLAB EDGES, 24" (SEE SCHEDULE) AWAY MINIMUM (i.e. - CORNER). SEE ADJACENT DETAIL FOR ADDITIONAL MINIMUM ALLOWABLE CONCRETE EDGE DISTANCES.
- TESTING OF EXPANSION ANCHORS PER 2016 CBC, 1910A.5: TESTING SHALL BE DONE IN THE PRESENCE OF THE SPECIAL INSPECTOR AND A REPORT OF THE TEST RESULTS SHALL BE SUBMITTED TO OSHPD.

(i) AFTER AT LEAST 24 HOURS HAVE ELAPSED SINCE INSTALLATION, TORQUE TEST AT LEAST 50% OF THE ANCHORS.

(ii) ACCEPTANCE CRITERIA:

- TORQUE TEST: THE APPLICABLE TORQUE MUST BE ACHIEVED WITHIN THE FOLLOWING LIMITS: WEDGE TYPE: 1/2 TURN OF THE NUT.

(iii) IF ANY ANCHORS FAILS, TEST ALL ANCHORS.

- AVOID DAMAGING EXISTING STEEL REINFORCING CONCRETE SLAB WHEN INSTALLING CONCRETE EXPANSION ANCHORS.
- PROVIDE FOR FULL THREAD ENGAGEMENT OF NUT & WASHER.

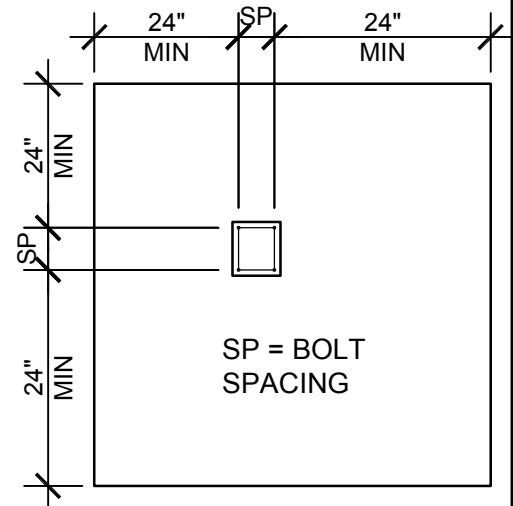

TYPICAL CONCRETE EDGE DETAIL

BOLTS THROUGH CONCRETE ON METAL DECK

- BOLTS SHALL BE TORQUED BY 3/4 TURN OF THE NUTS AFTER THE SNUG TIGHT (THE SNUG-TIGHT CONDITION IS DEFINED AS THE TIGHTNESS REQUIRED TO BRING THE CONNECTED PLIES INTO FIRM CONTACT) CONDITION IS ACHIEVED, UNLESS OTHERWISE NOTED.
- THROUGH BOLT HOLES SHALL BE 1/16" LARGER THAN BOLT SIZE (HOLE SIZE = BOLT SIZE + 1/16) FOR CONCRETE.
- THROUGH-BOLTS IN CONCRETE SHALL RECEIVE SPECIAL INSPECTION AND TESTING (THROUGH BOLTS WITH STEEL TO STEEL CONNECTION IN TENSION DO NOT REQUIRE TENSION TESTING) IN ACCORDANCE WITH REQUIREMENTS FOR POST-INSTALLED ANCHORS.





18400 Von Karman Ave.,  
Suite 600  
Irvine, CA 92612  
O: 949.252.1022  
F: 949.252.8082  
[www.kpff.com](http://www.kpff.com)

OLEA KIOSK OPM

BY: GN

SHEET NO.

-

DATE: 11-09-18

3

-

CHECKED: RG

JOB NO.

SEISMIC ANCHORAGE  
AT CONC SLAB ON MTL DECK ( $S_{DS} \leq 1.37$ )

1800184

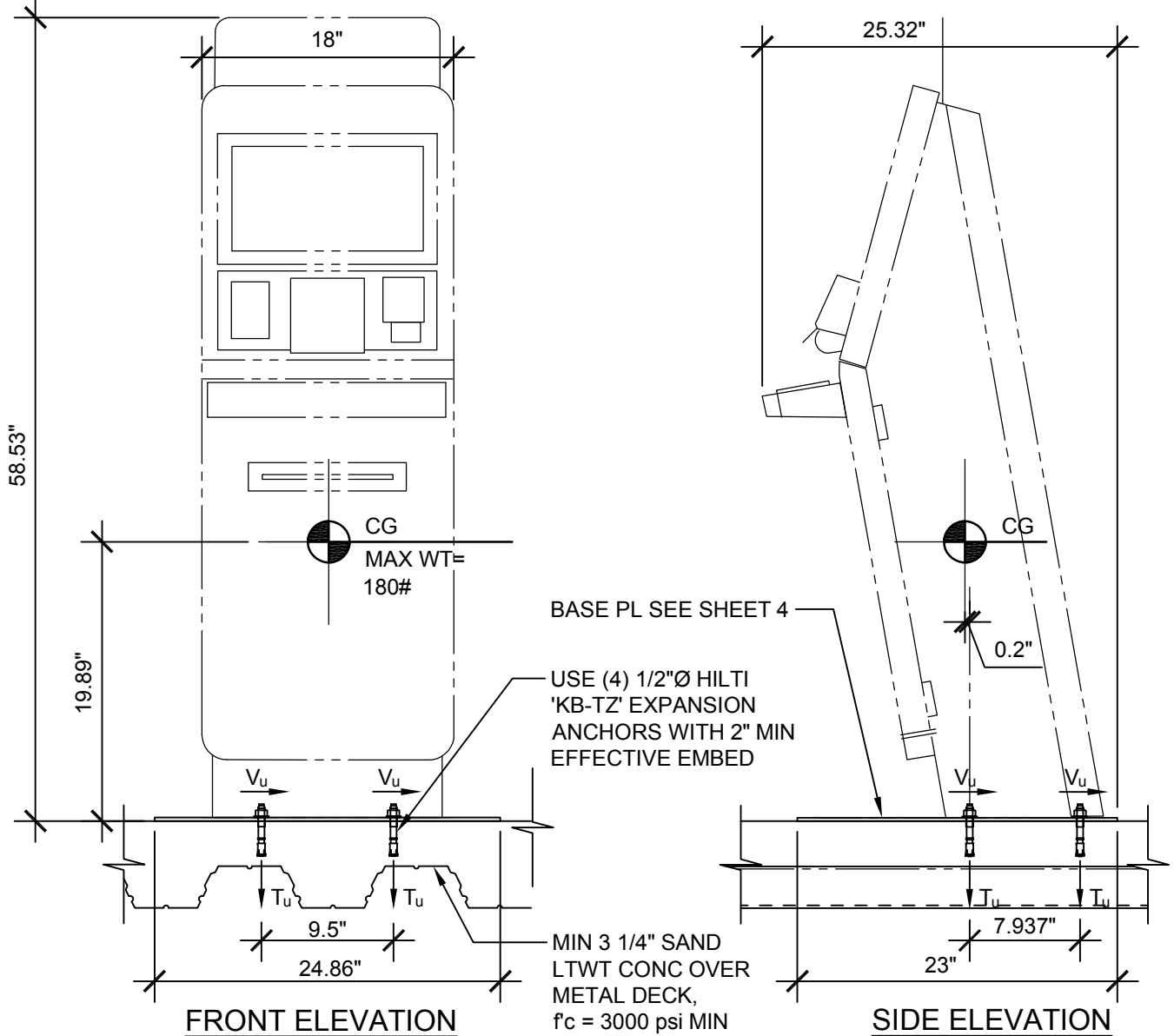

**NOTES:**

- FORCES ARE DETERMINED PER 2016 CALIFORNIA BUILDING CODE AND ASCE 7-10 STRENGTH DESIGN IS USED:  
-  $S_{DS}=1.37$ ,  $a_p=1.0$ ,  $I_p=1.5$ ,  $R_p=1.5$ ,  $\Omega_0=1.5$ ,  $z/h \leq 1.0$
- CENTER OF GRAVITY (CG) AND WEIGHT ARE THE GOVERNING PARAMETERS FOR DESIGN. THIS PREAPPROVAL ENCOMPASSES ALL WEIGHTS UP TO MAXIMUM WEIGHT SHOWN.
- STRUCTURAL ENGINEER OF RECORD FOR THE BUILDING SHALL PROVIDE SUPPORT STRUCTURE DESIGNED TO SUPPORT WEIGHTS AND FORCES SHOWN, IN COMBINATION WITH ALL OTHER LOADS THAT MAY BE PRESENT.
- FOR GENERAL NOTES SEE SHEETS 1 AND 2.





18400 Von Karman Ave.,  
Suite 600  
Irvine, CA 92612  
O: 949.252.1022  
F: 949.252.8082  
[www.kpff.com](http://www.kpff.com)

OLEA KIOSK OPM

BY: GN

SHEET NO.

-

DATE: 11-09-18

4

-

CHECKED: RG

JOB NO.

SEISMIC ANCHORAGE AT CONCRETE  
OVER METAL DECK

1800184

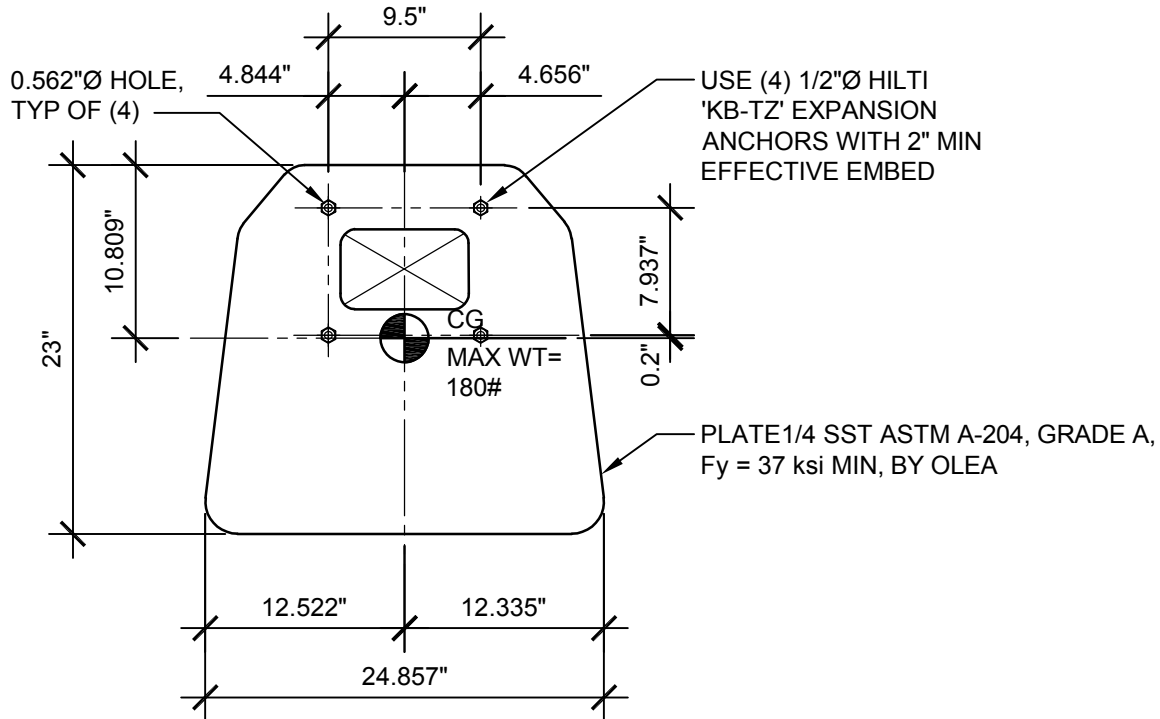

BASE PLATE

LOADS: PER 2016 CALIFORNIA BUILDING CODE AND ASCE 7-10

-  $S_{DS}=1.37$ ,  $a_p=1.0$ ,  $I_p=1.5$ ,  $R_p=1.5$ ,  $\Omega_0=1.5$ ,  $z/h \leq 1.0$

WEIGHT = 180#

HORIZONTAL FORCE ( $E_h$ ) =  $1.65 W_p = 297\#$

VERTICAL SEISMIC LOAD EFFECT ( $E_v$ ) =  $0.28 W_p = 50\#$

LOAD COMBINATION (STRENGTH) =  $0.9D + \Omega_0 E$

BOLT FORCES:

$\Omega_0 T_{MAX} = 730 \#/\text{BOLT}$ ,  $\Omega_0 V_{MAX} = 278 \#/\text{BOLT}$

BOLT CAPACITY: 1/2"Ø HILTI KB-TZ W/ 2" EFF EMBED

$\Phi T_n = 770\#$   $\Phi V_n = 1,106\#$

$$\left( \frac{\Omega_0 T_u}{\Phi T_n} \right) + \left( \frac{\Omega_0 V_u}{\Phi V_n} \right) = 1.20 \leq 1.2$$





18400 Von Karman Ave.,  
Suite 600  
Irvine, CA 92612  
O: 949.252.1022  
F: 949.252.8082  
[www.kpff.com](http://www.kpff.com)

OLEA KIOSK OPM

BY: GN

SHEET NO.

-

DATE: 11-09-18

5

-

CHECKED: RG

JOB NO.

1800184

SEISMIC ANCHORAGE AT  
CONC SLAB ON MTL DECK ( $1.37 < S_{DS} \leq 1.93$ )

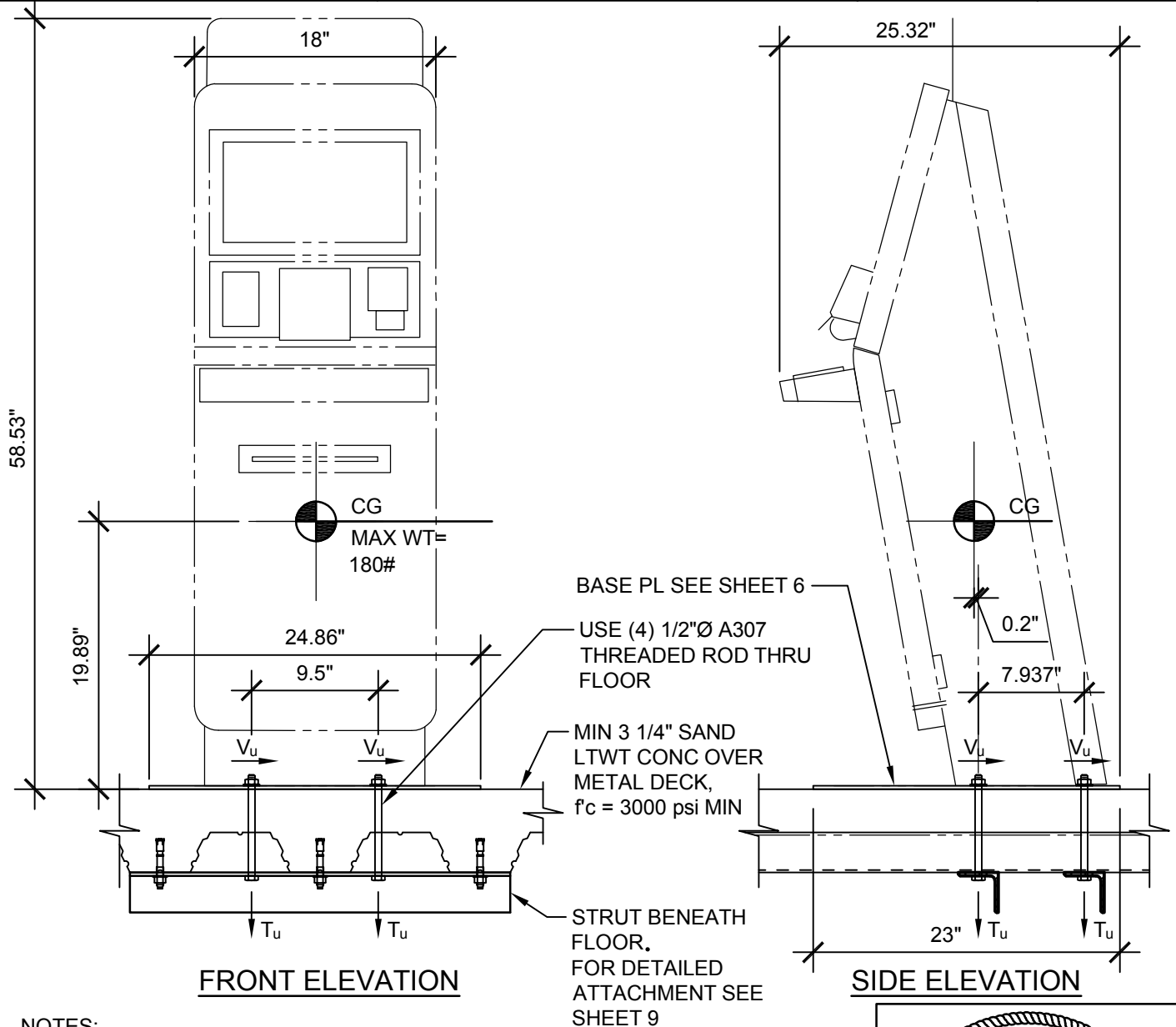

NOTES:

- FORCES ARE DETERMINED PER 2016 CALIFORNIA BUILDING CODE AND ASCE 7-10 STRENGTH DESIGN IS USED:  
-  $S_{DS}=1.93$ ,  $a_p=1.0$ ,  $I_p=1.5$ ,  $R_p=1.5$ ,  $z/h \leq 1.0$ ,  $\Omega_0=1.5$
- CENTER OF GRAVITY (CG) AND WEIGHT ARE THE GOVERNING PARAMETERS FOR DESIGN. THIS PREAPPROVAL ENCOMPASSES ALL WEIGHTS UP TO MAXIMUM WEIGHT SHOWN.
- STRUCTURAL ENGINEER OF RECORD FOR THE BUILDING SHALL PROVIDE SUPPORT STRUCTURE DESIGNED TO SUPPORT WEIGHTS AND FORCES SHOWN, IN COMBINATION WITH ALL OTHER LOADS THAT MAY BE PRESENT.
- FOR GENERAL NOTES SEE SHEETS 1 AND 2.





18400 Von Karman Ave.,  
Suite 600  
Irvine, CA 92612  
O: 949.252.1022  
F: 949.252.8082  
[www.kpff.com](http://www.kpff.com)

OLEA KIOSK OPM

BY: GN

SHEET NO.

-

DATE: 11-09-18

6

-

CHECKED: RG

JOB NO.

SEISMIC ANCHORAGE AT CONCRETE  
OVER METAL DECK

1800184

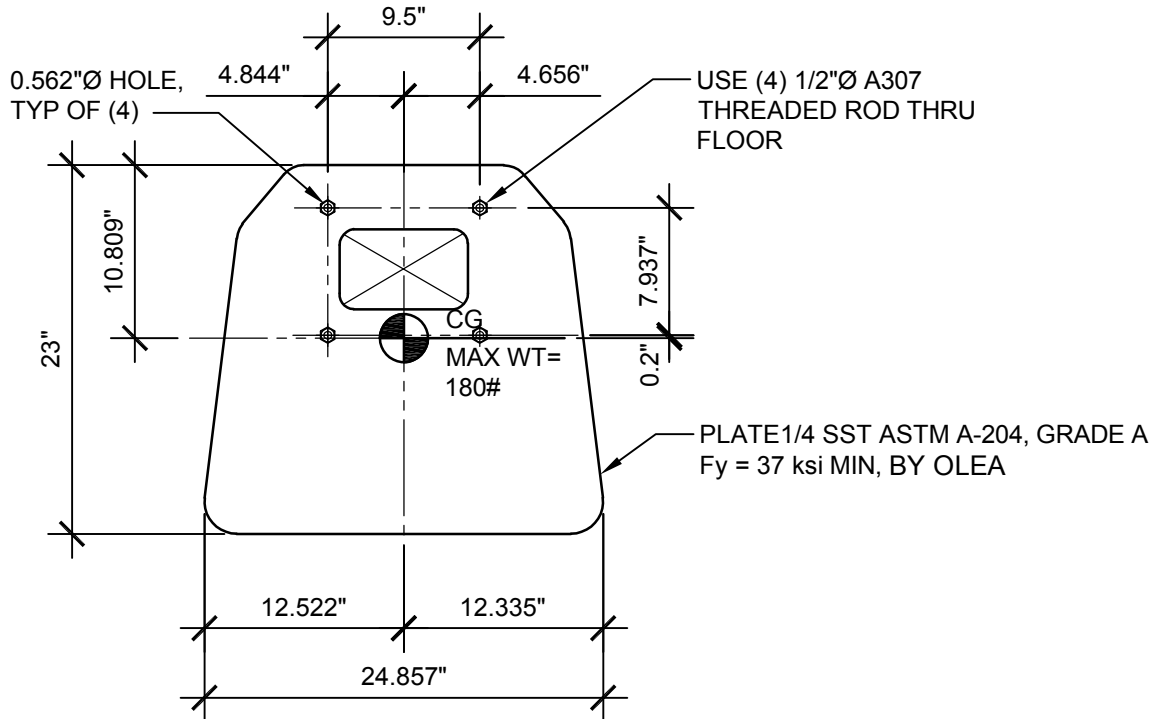

BASE PLATE

LOADS: PER 2016 CALIFORNIA BUILDING CODE AND ASCE 7-10

$S_{DS}=1.93$ ,  $a_p=1.0$ ,  $I_p=1.5$ ,  $R_p=1.5$ ,  $z/h \leq 1.0$ ,  $\Omega_0=1.5$

WEIGHT = 180#

HORIZONTAL FORCE ( $E_h$ ) =  $2.32 W_p = 418\#$

VERTICAL SEISMIC LOAD EFFECT ( $E_v$ ) =  $0.386 W_p = 69\#$

LOAD COMBINATION (STRENGTH) =  $0.9D + 1.0E$

BOLT FORCES:

$T_{MAX} = 686 \#/\text{BOLT}$ ,  $\Omega_0 V_{MAX} = 261 \#/\text{BOLT}$

BOLT CAPACITY: 1/2"Ø THREADED ROD, A307

$\Phi T_n = 5,751\#$

$\Phi V_n = 2,045\#$







18400 Von Karman Ave.,  
Suite 600  
Irvine, CA 92612  
O: 949.252.1022  
F: 949.252.8082  
[www.kpff.com](http://www.kpff.com)

OLEA KIOSK OPM

BY: GN

SHEET NO.

-

DATE: 11-09-18

7

-

CHECKED: RG

JOB NO.

SEISMIC ANCHORAGE AT CONCRETE SLAB

1800184

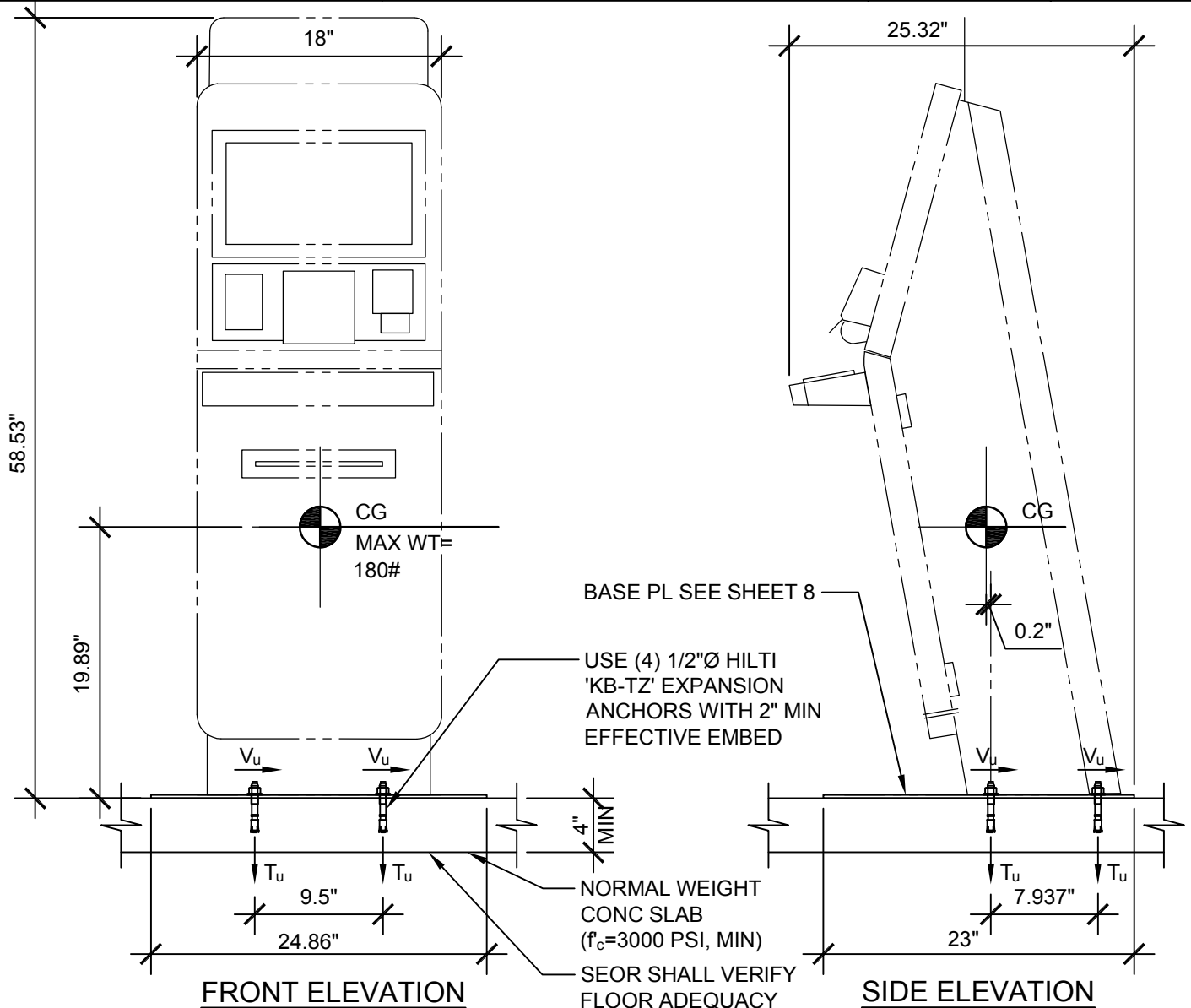

**NOTES:**

- FORCES ARE DETERMINED PER 2016 CALIFORNIA BUILDING CODE AND ASCE 7-10 STRENGTH DESIGN IS USED:  
-  $S_{DS}=1.93$ ,  $a_p=1.0$ ,  $I_p=1.5$ ,  $R_p=1.5$ ,  $\Omega_0=1.5$ ,  $z/h \leq 1.0$
- CENTER OF GRAVITY (CG) AND WEIGHT ARE THE GOVERNING PARAMETERS FOR DESIGN. THIS APPROVAL ENCOMPASSES ALL WEIGHTS UP TO MAXIMUM WEIGHT SHOWN.
- STRUCTURAL ENGINEER OF RECORD FOR THE BUILDING SHALL PROVIDE SUPPORT STRUCTURE DESIGNED TO SUPPORT WEIGHTS AND FORCES SHOWN, IN COMBINATION WITH ALL OTHER LOADS THAT MAY BE PRESENT.
- FOR GENERAL NOTES SEE SHEETS 1 AND 2.





18400 Von Karman Ave.,  
Suite 600  
Irvine, CA 92612  
O: 949.252.1022  
F: 949.252.8082  
[www.kpff.com](http://www.kpff.com)

OLEA KIOSK OPM

BY: GN

SHEET NO.

-

DATE: 11-09-18

8

-

CHECKED: RG

JOB NO.

SEISMIC ANCHORAGE AT CONCRETE  
SLAB

1800184

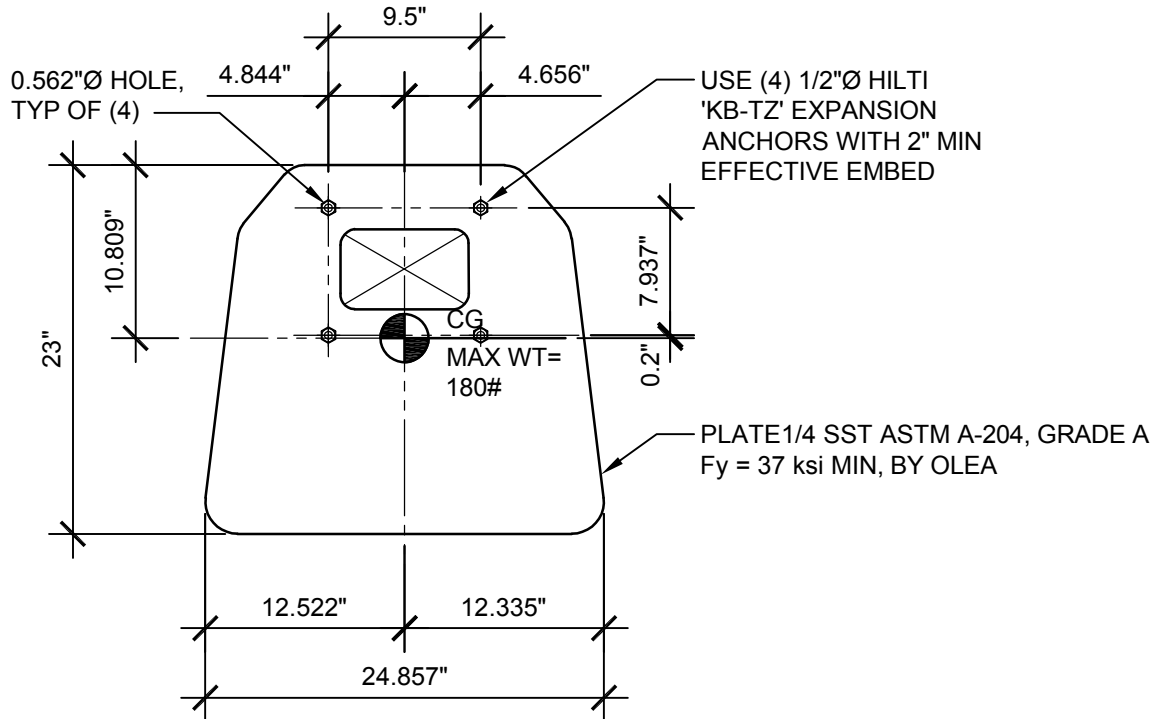

### BASE PLATE

LOADS: PER 2016 CALIFORNIA BUILDING CODE AND ASCE 7-10

$S_{DS}=1.93$ ,  $a_p=1.0$ ,  $I_p=1.5$ ,  $R_p=1.5$ ,  $\Omega_o=1.5$ ,  $z/h \leq 1.0$

WEIGHT = 180#

HORIZONTAL FORCE ( $E_h$ ) =  $2.32 W_p = 418\#$

VERTICAL SEISMIC LOAD EFFECT ( $E_v$ ) =  $0.386 W_p = 69\#$

LOAD COMBINATION (STRENGTH) =  $0.9D + \Omega_o E$

BOLT FORCES:

$\Omega_o T_{MAX} = 1028 \#/\text{BOLT}$ ,  $\Omega_o V_{MAX} = 391 \#/\text{BOLT}$

BOLT CAPACITY: 1/2"Ø HILTI KB-TZ W/ 2" EFF EMBED IN 4" NWC ( $f'_c=3000$  psi)

$\Phi T_n = 1,284\#$

$\Phi V_n = 1,844\#$

$$\left( \frac{\Omega_o T_u}{\Phi T_n} \right) + \left( \frac{\Omega_o V_u}{\Phi V_n} \right) = 1.01 \leq 1.2$$





18400 Von Karman Ave.,  
Suite 600  
Irvine, CA 92612  
O: 949.252.1022  
F: 949.252.8082  
[www.kpff.com](http://www.kpff.com)

OLEA KIOSK OPM

BY: GN

SHEET NO.

-

DATE: 11-09-18

9

-

CHECKED: RG

JOB NO.

SEISMIC ANCHORAGE - STRUT DETAIL

1800184

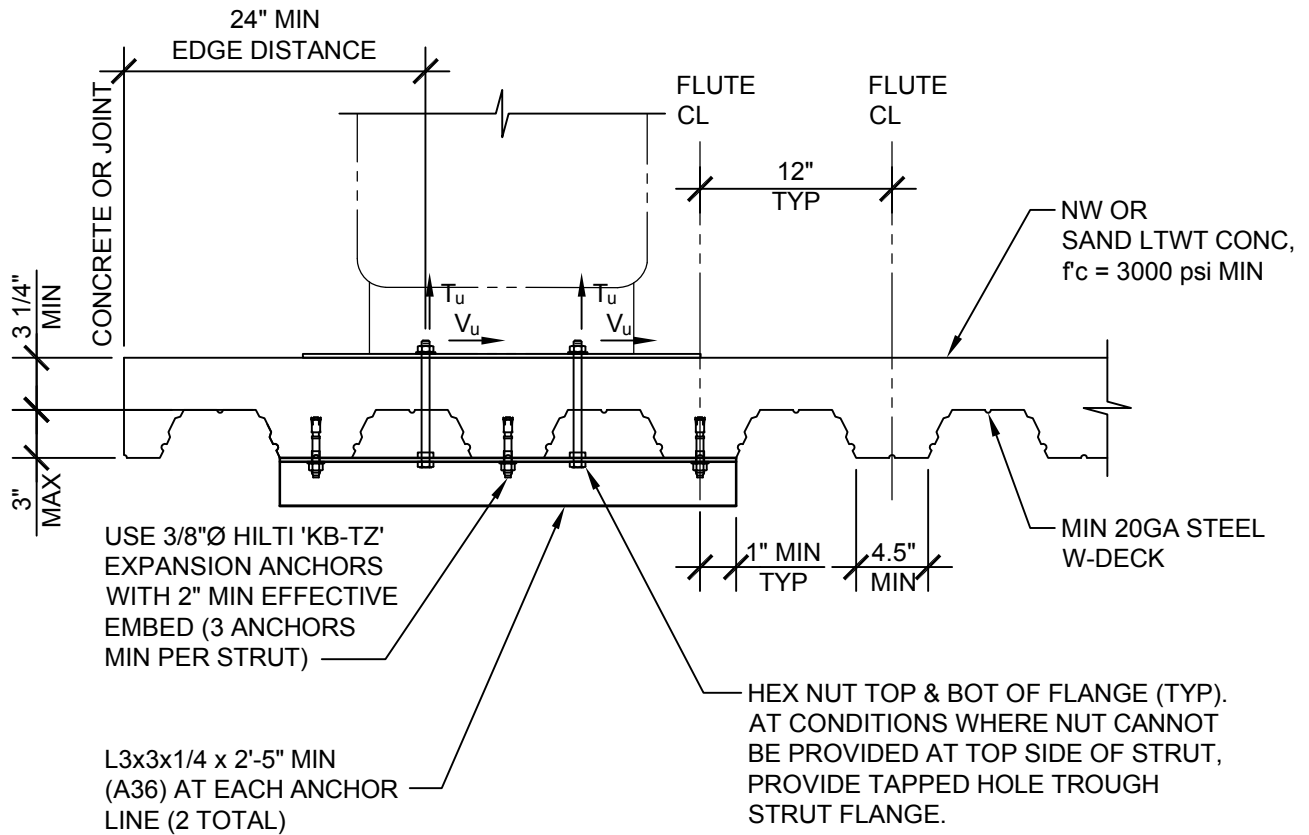

**MINIMUM STEEL DECK REQUIREMENTS & STRUT DETAIL**

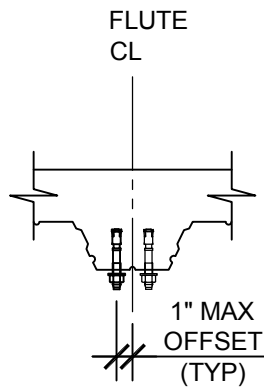

**FLUTE DETAIL**

