



OFFICE OF STATEWIDE HEALTH PLANNING AND DEVELOPMENT
FACILITIES DEVELOPMENT DIVISION

APPLICATION FOR OSHPD PREAPPROVAL OF
MANUFACTURER'S CERTIFICATION (OPM)

OFFICE USE ONLY

APPLICATION #: OPM-0484

OSHPD Preapproval of Manufacturer's Certification (OPM)

Type: [ ] New [X] Renewal/Update

Manufacturer Information

Manufacturer: Steris Corporation

Manufacturer's Technical Representative: Zachary Miday

Mailing Address: 5900 Heisley Road, Mentor, OH 44060

Telephone: (440) 392-7688

Email: Zachary\_Miday@steris.com

Product Information

Product Name: 26 X 37.5 STEAM STERILIZER

Product Type: Steam Sterilizer (Process Type)

Product Model Number: AMSCO 400, Century, Evolution, Evolution L, & 630 LS

General Description: Steam sterilizers are designed for fast, efficient sterilization of heat and moisture material Stable material in life science and healthcare applications, floor Mounted Sterilizer.

Applicant Information

Applicant Company Name: Engineering ONE Group, Inc.

Contact Person: James Yan

Mailing Address: 16551 4S Ranch Pkwy, San Diego, CA 92127

Telephone: (858) 876-8695

Email: jyan@engineeringonegroup.com

Title: Structural Engineer

\*Access to Safe, Quality Healthcare Environments that Meet California's Diverse and Dynamic Needs\*

STATE OF CALIFORNIA- HEALTH AND HUMAN SERVICES AGENCY





# OFFICE OF STATEWIDE HEALTH PLANNING AND DEVELOPMENT FACILITIES DEVELOPMENT DIVISION

## Registered Design Professional Preparing Engineering Recommendations

Company Name: JAMES YAN (SOLE PROPRIETORSHIP)

Name: James Yan

California License Number: S5914

Mailing Address: 17130 Glen Aspen Dr., San Diego, CA 92127

Telephone: (626) 226-8695

Email: james.linjun.yan@gmail.com

## OSHPD Special Seismic Certification Preapproval (OSP)

Special Seismic Certification is preapproved under OSP

OSP Number: \_\_\_\_\_

## Certification Method

Testing in accordance with:  ICC-ES AC156  FM 1950-16

Other(s) (Please Specify): \_\_\_\_\_

\*Use of criteria other than those adopted by the California Building Standards Code, 2019 (CBSC 2019) for component supports and attachments are not permitted. For distribution system, interior partition wall, and suspended ceiling seismic bracings, test criteria other than those adopted in the CBSC 2019 may be used when approved by OSHPD prior to testing.

Analysis

Experience Data

Combination of Testing, Analysis, and/or Experience Data (Please Specify): \_\_\_\_\_

## OSHPD Approval

Date: 6/24/2020

Name: Jeffrey Kikumoto

Title: Senior Structural Engineer

Condition of Approval (if applicable): \_\_\_\_\_

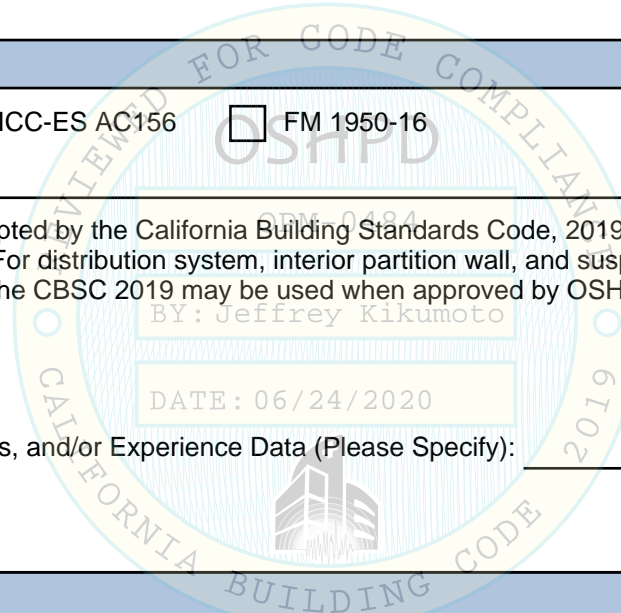



ENGINEERING ONE GROUP, INC.  
 Phone: 858.876.8695  
 info@engineeringonegroup.com  
 www.engineeringonegroup.com

# STERIS CORPORATION

STEAM STERILIZERS 26" X 37.5"

SHEET 1  
 OF 16 SHEETS

Job No. 200001  
 Date 04/26/2020  
 Drawn by JY

Office of Statewide Health Planning and Development  
 OSHPD Preapproval of Manufacturer's Certification

## OPM-0484-19

THIS PRE-APPROVAL CONFORMS TO THE 2019 CALIFORNIA BUILDING CODE

EQUIPMENT MANUFACTURER: STERIS CORPORATION  
 EQUIPMENT TYPE: EVOLUTION, EVOLUTION L, 630 LS, AMSCO 400 & CENTURY

### GENERAL NOTES

1. THIS OSHPD PREAPPROVAL OF MANUFACTURER'S CERTIFICATION (OPM) IS BASED ON THE CBC 2019. THE DEMAND (DESIGN FORCES) FOR USE WITH THIS OPM SHALL BE BASED ON THE CBC 2019.
2. THIS PRE-APPROVAL COVERS ONLY THE SUPPORTS & ATTACHMENTS OF THE EQUIPMENT TO THE STRUCTURE.
3. POST-INSTALLED ANCHORS:
  - a. ATTACHMENT IS TO BE MADE WITH THE ANCHORS LISTED BELOW AND INSTALLED AS DESCRIBED IN THE CORRESPONDING ICC REPORT.
  - b. THIS PRE-APPROVAL REQUIRES CONCRETE SLAB EDGE DISTANCE TO BE 18" MIN.
  - c. AVOID DAMAGING (E) STEEL REINF'G IN CONCRETE SLAB WHEN INSTALLING CONCRETE EXPANSIVE ANCHORS.
  - d. PROVIDE FULL THREAD ENGAGEMENT OF NUT & WASHER.

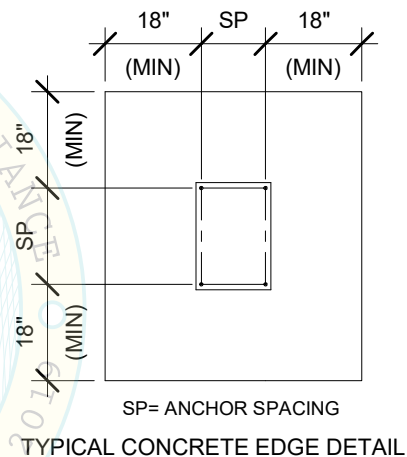

Anchor Diameter	Concrete Type	Min. fc (psi)	Anchor Type	ICC Report No.	Min. Embed. (hef)	Min. Spacing	Min. Edge Dist.	Min. Conc. Thickness	Installation. Torque	Test Loads
3/4"	N.W.	4000	HIT-RE 500 V3 + HAS-R 316 SS	ESR-3814	6"	12"	18"	8"	100 Ft-Lb	Hydraulic Ram Method 11555 Lb
1/2"	N.W. OR SAND L.W. FOR CONC. OVER METAL DECK	3000	KB-TZ SS304	ESR-1917	2"	12"	18"	6"	40 Ft-Lb	Torque Wrench Method 40 Ft-Lb

3. TESTING OF POST-INSTALLED ANCHORS PER 2019 CBC, 1910A.5 : TENSION TESTING SHALL BE DONE IN THE PRESENCE OF THE SPECIAL INSPECTOR AND A REPORT OF THE TEST RESULTS SHALL BE SUBMITTED.
  - a. 50 PERCENT OR ALTERNATE BOLTS IN A GROUP SHALL BE TESTED.
  - b. TESTING SHALL OCCUR A MINIMUM OF 24 HOURS AFTER INSTALLATION OF THE SUBJECT ANCHORS.
  - c. ACCEPTANCE CRITERIA:
    - HYDRAULIC RAM METHOD: THE ANCHOR SHOULD HAVE NO OBSERVABLE MOVEMENT AT THE TEST LOAD. A PRACTICAL WAY TO DETERMINE OBSERVABLE MOVEMENT IS THAT THE WASHER BECOMES LOOSE.
    - TORQUE WRENCH METHOD: ANCHORS TESTED WITH A CALIBRATED TORQUE WRENCH MUST ATTAIN THE SPECIFIED TORQUE WITHIN 1/2 TURN OF THE NUT.
  - d. IF ANY ANCHOR FAILS, TEST ALL ANCHORS.



4/26/2020 4:51:51 PM



ENGINEERING ONE GROUP, INC.  
 Phone: 858.876.8695  
 info@engineeringonegroup.com  
 www.engineeringonegroup.com

# STERIS CORPORATION

## STEAM STERILIZERS 26" X 37.5"

SHEET 2  
 OF 16 SHEETS

Job No. 200001

Date 04/26/2020

Drawn by JY

### STEAM STERILIZER SCHEDULE

LINE NO.	MODLE ID	OVERALL			ANCHOR SPACING		C.G. HEIGHT (in)	WEIGHT (lbs)
		WIDTH (in)	LENGTH (in)	HEIGHT (in)	F/B (in)	S/S (in)		
1	EVOLUTION, EVOLUTION L, 630LS 42 SD	65	91.25	77.25	51.38	35	42	3800
2	EVOLUTION, EVOLUTION L, 630LS 54 SD	77	91.25	77.25	63.38	35	42	4200
3	EVOLUTION, EVOLUTION L, 630LS 66 SD	89	91.25	77.25	75.38	35	42	4700
4	EVOLUTION, EVOLUTION L, 630LS 42 DD	62.25	91.25	77.25	51.88	35	42	3800
5	EVOLUTION, EVOLUTION L, 630LS 54 DD	65.25	91.25	77.25	63.88	35	42	4200
6	EVOLUTION, EVOLUTION L, 630LS 66 DD	77.25	91.25	77.25	75.88	35	42	4700
7	AMSCO 400 36 SD	63.50	70	75.25	23	47	36	3800
8	AMSCO 400 48 SD	75.50	70	75.25	35	47	36	4200
9	AMSCO 400 60 SD	87.50	70	75.25	47	47	36	4700
10	AMSCO 400 36 DD	62.25	70	75.25	23.50	47	36	3800
11	AMSCO 400 48 DD	74.25	70	75.25	35.50	47	36	4200
12	AMSCO 400 60 DD	86.25	70	75.25	47.50	47	36	4700
13	CENTURY 36 SD	59	70	75.25	23	47	36	3800
14	CENTURY 48 SD	71	70	75.25	35	47	36	4200
15	CENTURY 60 SD	83	70	75.25	47	47	36	4700
16	CENTURY 36 DD	58.25	70	75.25	23.50	47	36	3800
17	CENTURY 48 DD	70.25	70	75.25	35.50	47	36	4200
18	CENTURY 60 DD	82.25	70	75.25	47.50	47	36	4700

NOTE:

F/S: FRONT TO BACK  
 S/S: SIDE TO SIDE  
 SD: SINGLE DOOR  
 DD: DOUBLE DOOR



4/26/2020 4:51:51 PM



ENGINEERING ONE GROUP, INC.  
 Phone: 858.876.8695  
 info@engineeringonegroup.com  
 www.engineeringonegroup.com

# STERIS CORPORATION

## STEAM STERILIZERS 26" X 37.5"

SHEET 3  
 OF 16 SHEETS

Job No.	200001
Date	04/26/2020
Drawn by	JY

### GENERAL NOTES (CONTINUED)

- FORCES PER ASCE 7-16 SECTION 13.3.1, EQUATIONS 13.3-1, 13.3-2 & 13.3-3, WHERE  
 $S_{DS} = 2.12$   
 $a_p = 1.0$   
 $I_p = 1.5$   
 $R_p = 2.5$   
 $\Omega_0 = 2.0$   
 $z/h = 0$ (CASE 1) & 1(CASE 2)
- ALL ANCHOR FORCES SHOWN ON THE DRAWINGS ARE FACTORED LOADS THAT SHALL BE USED FOR STRENGTH DESIGN.

### RESPONSIBILITIES OF THE STRUCTURAL ENGINEER OF RECORD OF THE BUILDING

- VERIFY THAT PROJECT SPECIFIC VALUES OF  $S_{DS}$  &  $z/h$  RESULT IN SEISMIC FORCES ( $E_h$ ,  $E_v$ ) THAT DO NOT EXCEED THE VALUES ON THE DETAILS.
- VERIFY THAT THE CONCRETE SLAB TO WHICH THE EQUIPMENT IS ANCHORED MEETS THE REQUIREMENTS OF THE APPLICABLE ICC ESR.
- VERIFY THAT THE ANCHORS ARE AN ADEQUATE DISTANCE FROM ANY SLAB EDGES OR OPENINGS (SEE TYPICAL DETAIL ON SHEET 1).
- VERIFY THAT ALL NEW OR EXISTING ANCHORS ARE AN ADEQUATE DISTANCE FROM THE ANCHORS SHOWN IN THIS PRE-APPROVAL. SEOR SHALL VERIFY THAT THERE IS NO ADVERSE INTERACTION WHERE OTHER ANCHORS ARE WITHIN 18" OR  $6h_{ef}$  FROM THIS UNIT'S ANCHORS.
- PROVIDE SUPPORTING STRUCTURE TO SUPPORT WEIGHTS AND FORCES SHOWN, IN ADDITION TO ALL OTHER LOADS. VERIFY THE ADEQUACY OF THE STRUCTURES (SUCH AS WALLS AND FLOORS) WHICH SUPPORT THE EQUIPMENT FOR THE LOADS IMPOSED ON THEM BY THE EQUIPMENT IN ADDITION TO ALL OTHER LOADS.
- VERIFY THAT THE INSTALLATION IS IN CONFORMANCE WITH THE 2016 CBC AND WITH THE DETAILS SHOWN IN THIS PRE-APPROVAL. VERIFY THAT THE ACTUAL EQUIPMENT'S WEIGHT, CG LOCATION, ANCHOR LOCATIONS, ANCHOR DETAILS, AND THE MATERIAL AND GAGE OF THE UNIT WHERE ATTACHMENTS ARE MADE AGREE WITH THE INFORMATION SHOWN ON THE PRE-APPROVAL DOCUMENTS.



4/26/2020 4:51:51 PM



ENGINEERING ONE GROUP, INC.  
 Phone: 858.876.8695  
 info@engineeringonegroup.com  
 www.engineeringonegroup.com

# STERIS CORPORATION

STEAM STERILIZERS 26" X 37.5"

SHEET 4  
 OF 13 SHEETS

Job No. 200001  
 Date 04/26/2020  
 Drawn by JY

SEISMIC SUPPORTS & ATTACHMENTS

SLAB ON GRADE  
 (CASE 1)  
 $S_{DS}=2.12, z/h=0$

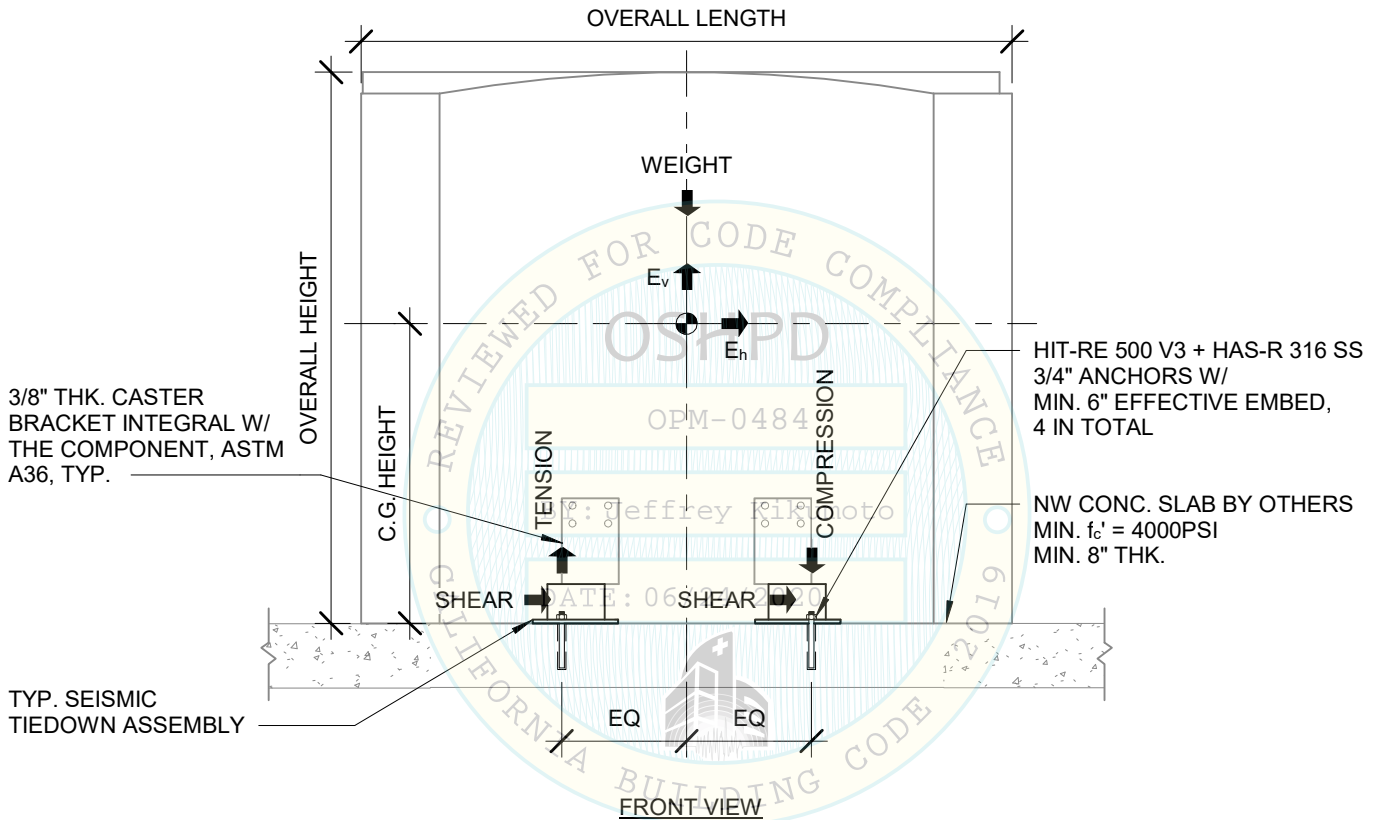

NOTE:

- FORCES ARE DETERMINED PER 2019 CALIFORNIA BUILDING CODE AND ASCE 7-16. STRENGTH DESIGN IS USED.  
 HORIZONTAL SEISMIC FORCE ( $E_h$ ) =  $0.954 W_p$   
 VERTICAL SEISMIC FORCE ( $E_v$ ) =  $0.424 W_p$
- CENTER OF GRAVITY (C.G.) WEIGHT IS A MAXIMUM. THIS PRE-APPROVAL ENCOMPASSES ALL WEIGHTS UP TO THE MAXIMUM WEIGHT SHOWN.
- STRUCTURAL ENGINEER OF RECORD SHALL VERIFY ADEQUACY OF SLAB ON GRADE AND OTHER SUPPORTING STRUCTURE TO SUPPORT WEIGHTS AND FORCES SHOWN.
- SEE SHEET 2 FOR THE OVERALL DIMENSIONS.



4/26/2020 4:51:51 PM



ENGINEERING ONE GROUP, INC.  
 Phone: 858.876.8695  
 info@engineeringonegroup.com  
 www.engineeringonegroup.com

# STERIS CORPORATION

## STEAM STERILIZERS 26" X 37.5"

SHEET 5  
 OF 13 SHEETS

Job No. 200001  
 Date 04/26/2020  
 Drawn by JY

### SEISMIC SUPPORTS & ATTACHMENTS

SLAB ON GRADE  
 (CASE 1)  
 $S_{DS}=2.12, z/h=0$

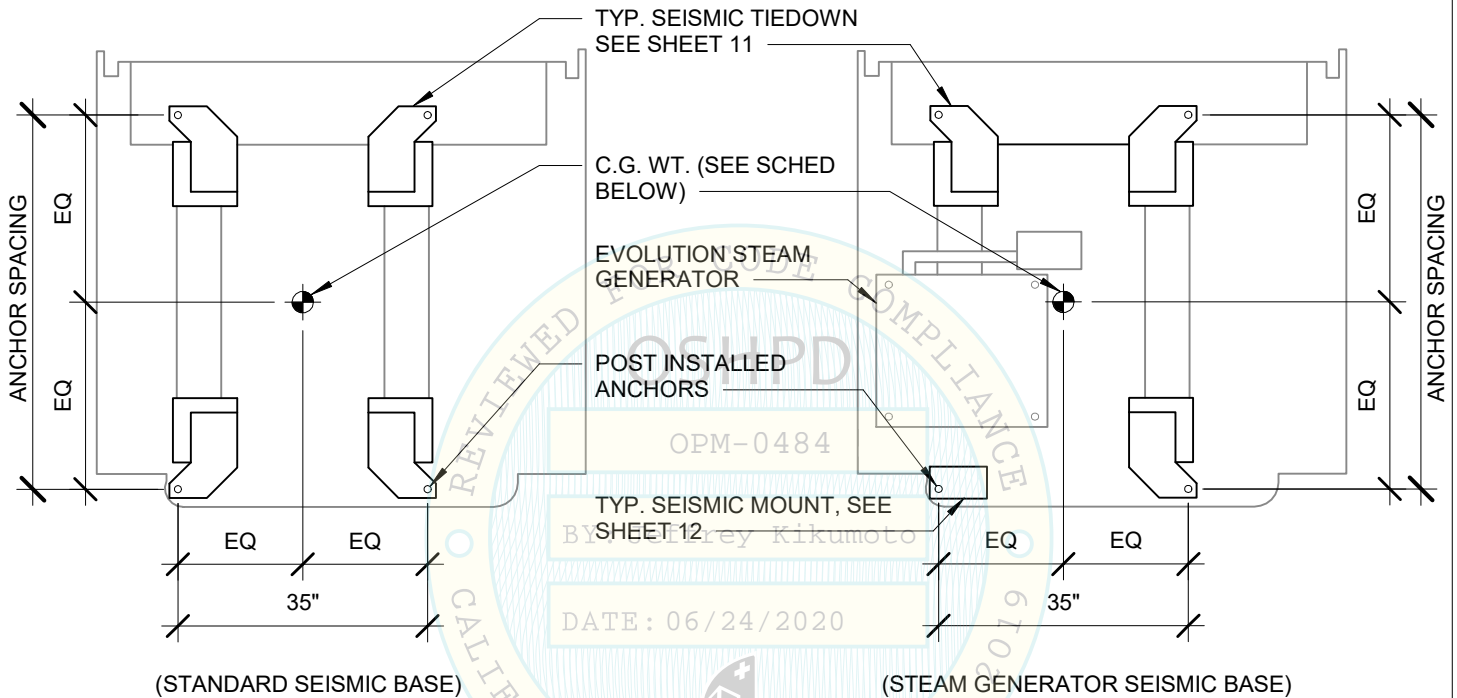

PLAN VIEW AT BASE OF LINE NO. 1-6

LINE NO.	MODEL ID	WEIGHT (lbs)	$V_u$ /bolt (lbs)	$T_u$ /bolt (lbs)
1	EVOLUTION, EVOLUTION L, 630LS 42SD	3800	2356	4787
2	EVOLUTION, EVOLUTION L, 630LS 54SD	4200	2604	5105
3	EVOLUTION, EVOLUTION L, 630LS 66SD	4700	2914	5571
4	EVOLUTION, EVOLUTION L, 630LS 42DD	3800	2356	4787
5	EVOLUTION, EVOLUTION L, 630LS 54DD	4200	2604	5105
6	EVOLUTION, EVOLUTION L, 630LS 66DD	4700	2914	5571

**NOTE:**

- THE SHOWN ANCHOR FORCE CALCULATION INCLUDES OVERSTRENGTH FACTOR  $\Omega_0 = 2.0$
- SEE SHEET 2 FOR ANCHOR SPACING.





ENGINEERING ONE GROUP, INC.  
 Phone: 858.876.8695  
 info@engineeringonegroup.com  
 www.engineeringonegroup.com

# STERIS CORPORATION

## STEAM STERILIZERS 26" X 37.5"

SHEET 6  
 OF 13 SHEETS

Job No. 200001

Date 04/26/2020

Drawn by JY

**SEISMIC SUPPORTS & ATTACHMENTS**

**SLAB ON GRADE**  
 (CASE 1)  
 $S_{ds}=2.12, z/h=0$

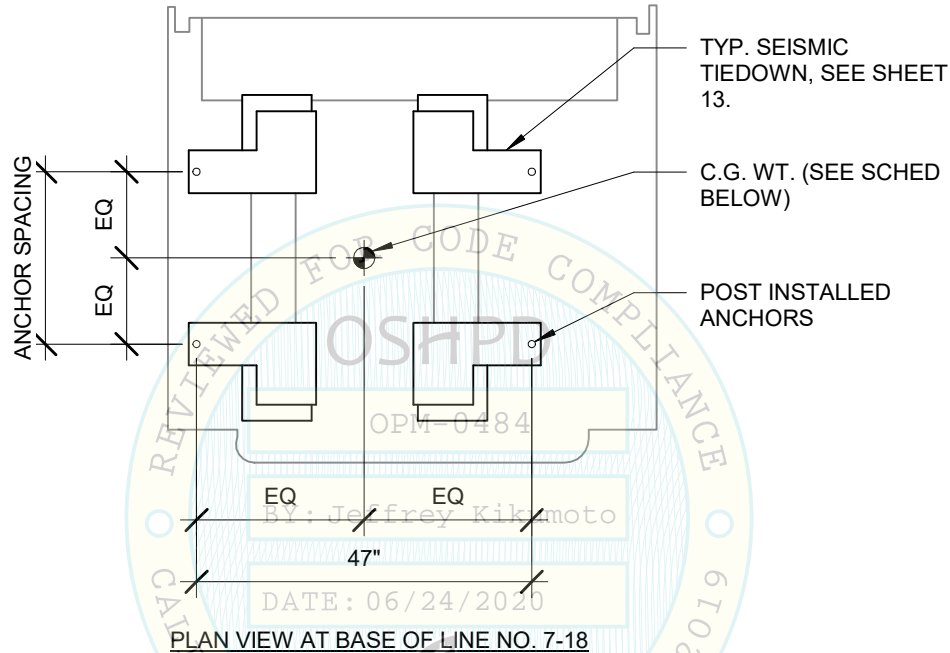

PLAN VIEW AT BASE OF LINE NO. 7-18

LINE NO.	MODEL ID	WEIGHT (lbs)	$V_u$ /bolt (lbs)	$T_u$ /bolt (lbs)
7	AMSCO 400 36 SD	3800	2356	6055
8	AMSCO 400 48 SD	4200	2604	4542
9	AMSCO 400 60 SD	4700	2914	3905
10	AMSCO 400 36 DD	3800	2356	5934
11	AMSCO 400 48 DD	4200	2604	4484
12	AMSCO 400 60 DD	4700	2914	3869
13	CENTURY 36 SD	3800	2356	6055
14	CENTURY 48 SD	4200	2604	4542
15	CENTURY 60 SD	4700	2914	3905
16	CENTURY 36 DD	3800	2356	5934
17	CENTURY 48 DD	4200	2604	4484
18	CENTURY 60 DD	4700	2914	3869

**NOTE:**

- THE SHOWN ANCHOR FORCE CALCULATION INCLUDES OVERSTRENGTH FACTOR  $\Omega_0 = 2.0$
- SEE SHEET 2 FOR ANCHOR SPACING.







ENGINEERING ONE GROUP, INC.  
 Phone: 858.876.8695  
 info@engineeringonegroup.com  
 www.engineeringonegroup.com

# STERIS CORPORATION

STEAM STERILIZERS 26" X 37.5"

SHEET 7  
 OF 13 SHEETS

Job No. 200001  
 Date 04/26/2020  
 Drawn by JY

SEISMIC SUPPORTS & ATTACHMENTS

UPPER FLOOR  
 (CASE 2)  
 $S_{DS}=2.12, z/h \leq 1$

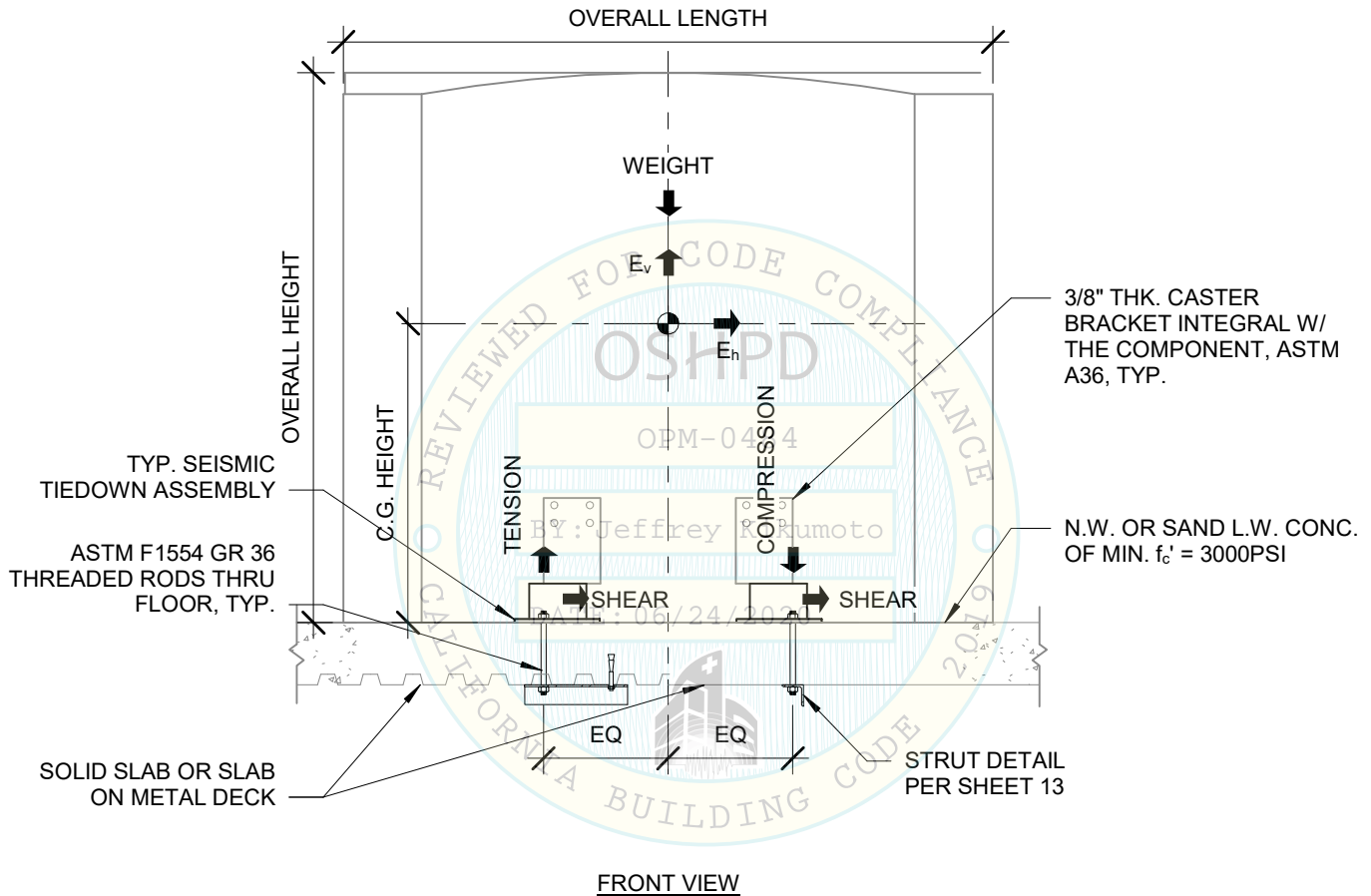

NOTE:

- FORCES ARE DETERMINED PER 2019 CALIFORNIA BUILDING CODE AND ASCE 7-16. STRENGTH DESIGN IS USED.  
 HORIZONTAL SEISMIC FORCE ( $E_h$ ) =  $1.526 W_p$   
 VERTICAL SEISMIC FORCE ( $E_v$ ) =  $0.424 W_p$
- CENTER OF GRAVITY (C.G.) WEIGHT IS A MAXIMUM. THIS PRE-APPROVAL ENCOMPASSES ALL WEIGHTS UP TO THE MAXIMUM WEIGHT SHOWN.
- STRUCTURAL ENGINEER OF RECORD SHALL VERIFY ADEQUACY OF CONC. METAL DECK AND OTHER SUPPORTING STRUCTURE TO SUPPORT WEIGHTS AND FORCES SHOWN.
- SEE SHEET 2 FOR THE OVERALL DIMENSIONS.

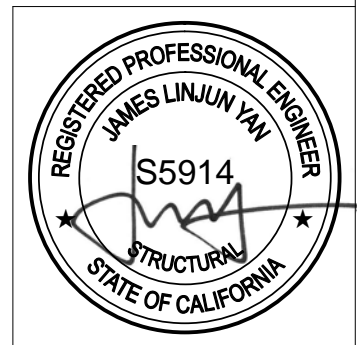

4/26/2020 4:51:51 PM



ENGINEERING ONE GROUP, INC.  
 Phone: 858.876.8695  
 info@engineeringonegroup.com  
 www.engineeringonegroup.com

# STERIS CORPORATION

## STEAM STERILIZERS 26" X 37.5"

SHEET 8  
 OF 13 SHEETS

Job No. 200001

Date 04/26/2020

Drawn by JY

### SEISMIC SUPPORTS & ATTACHMENTS

UPPER FLOOR  
 (CASE 2)  
 $S_{DS}=2.12, z/h \leq 1$

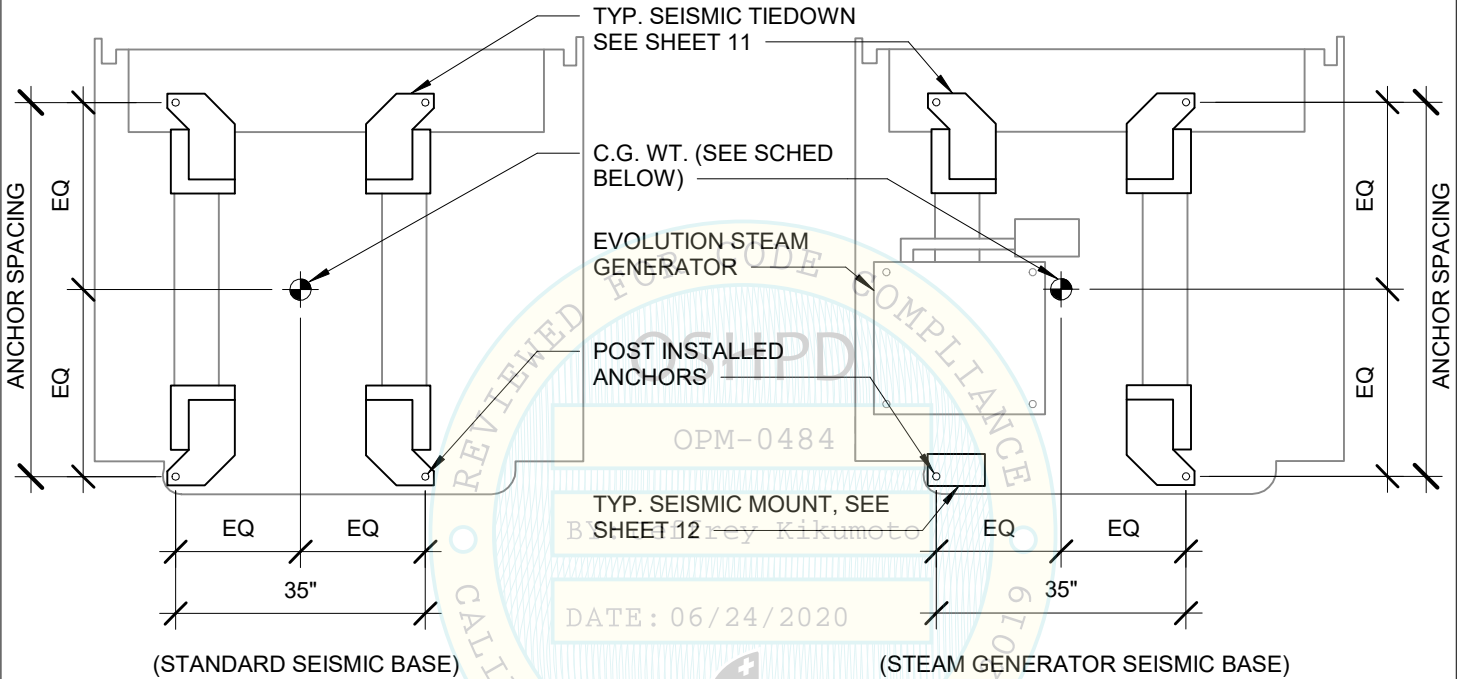

PLAN VIEW AT BASE OF LINE NO. 1-6

LINE NO.	MODEL ID	WEIGHT (lbs)	$V_u$ /bolt (lbs)	$T_u$ /bolt (lbs)
1	EVOLUTION, EVOLUTION L, 630LS 42SD	3800	1885	3739
2	EVOLUTION, EVOLUTION L, 630LS 54SD	4200	2084	3984
3	EVOLUTION, EVOLUTION L, 630LS 66SD	4700	2332	4345
4	EVOLUTION, EVOLUTION L, 630LS 42DD	3800	1885	3739
5	EVOLUTION, EVOLUTION L, 630LS 54DD	4200	2084	3984
6	EVOLUTION, EVOLUTION L, 630LS 66DD	4700	2332	4345

**NOTE:**

- THE SHOWN ANCHOR FORCE CALCULATION DOES NOT INCLUDE OVERSTRENGTH FACTOR  $\Omega_0 = 2.0$ .
- SEE SHEET 2 FOR ANCHOR SPACING.

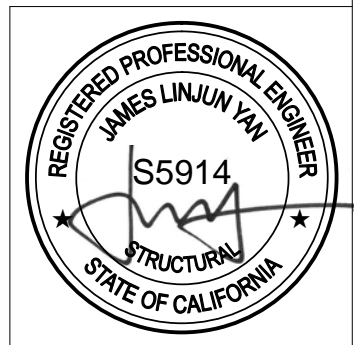

4/26/2020 4:51:51 PM



ENGINEERING ONE GROUP, INC.  
 Phone: 858.876.8695  
 info@engineeringonegroup.com  
 www.engineeringonegroup.com

# STERIS CORPORATION

## STEAM STERILIZERS 26" X 37.5"

SHEET 9  
 OF 13 SHEETS

Job No. 200001  
 Date 04/26/2020  
 Drawn by JY

### SEISMIC SUPPORTS & ATTACHMENTS

UPPER FLOOR  
 (CASE 2)  
 $S_{DS}=2.12, z/h \leq 1$

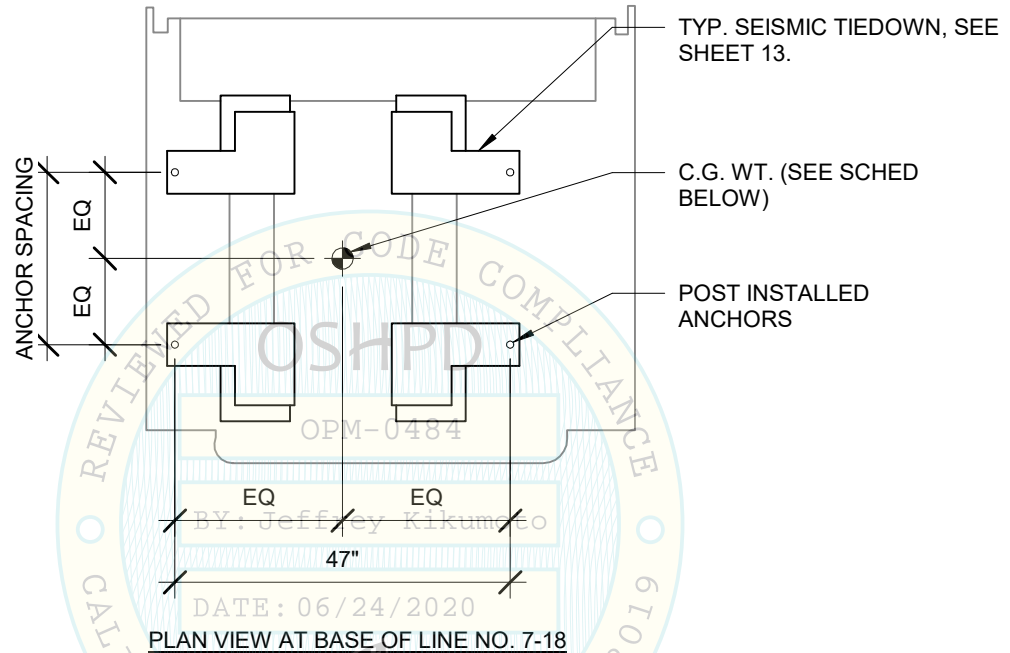

PLAN VIEW AT BASE OF LINE NO. 7-18

LINE NO.	MODEL ID	WEIGHT (lbs)	$V_u$ /bolt (lbs)	$T_u$ /bolt (lbs)
7	AMSCO 400 36 SD	3800	1885	4754
8	AMSCO 400 48 SD	4200	2084	3534
9	AMSCO 400 60 SD	4700	2332	3012
10	AMSCO 400 36 DD	3800	1885	4657
11	AMSCO 400 48 DD	4200	2084	3487
12	AMSCO 400 60 DD	4700	2332	3004
13	CENTURY 36 SD	3800	1885	4754
14	CENTURY 48 SD	4200	2084	3534
15	CENTURY 60 SD	4700	2332	3012
16	CENTURY 36 DD	3800	1885	4657
17	CENTURY 48 DD	4200	2084	3487
18	CENTURY 60 DD	4700	2332	3004

**NOTE:**

- THE SHOWN ANCHOR FORCE CALCULATION DOES NOT INCLUDE OVERSTRENGTH FACTOR  $\Omega_0 = 2.0$ .
- SEE SHEET 2 FOR ANCHOR SPACING.



4/26/2020 4:51:51 PM



**ENGINEERING ONE GROUP, INC.**  
 Phone: 858.876.8695  
 info@engineeringonegroup.com  
 www.engineeringonegroup.com

# STERIS CORPORATION

**SHEET 10**  
**OF 13 SHEETS**

## STEAM STERILIZERS 26" X 37.5"

Job No. 200001

Date 04/26/2020

Drawn by JY

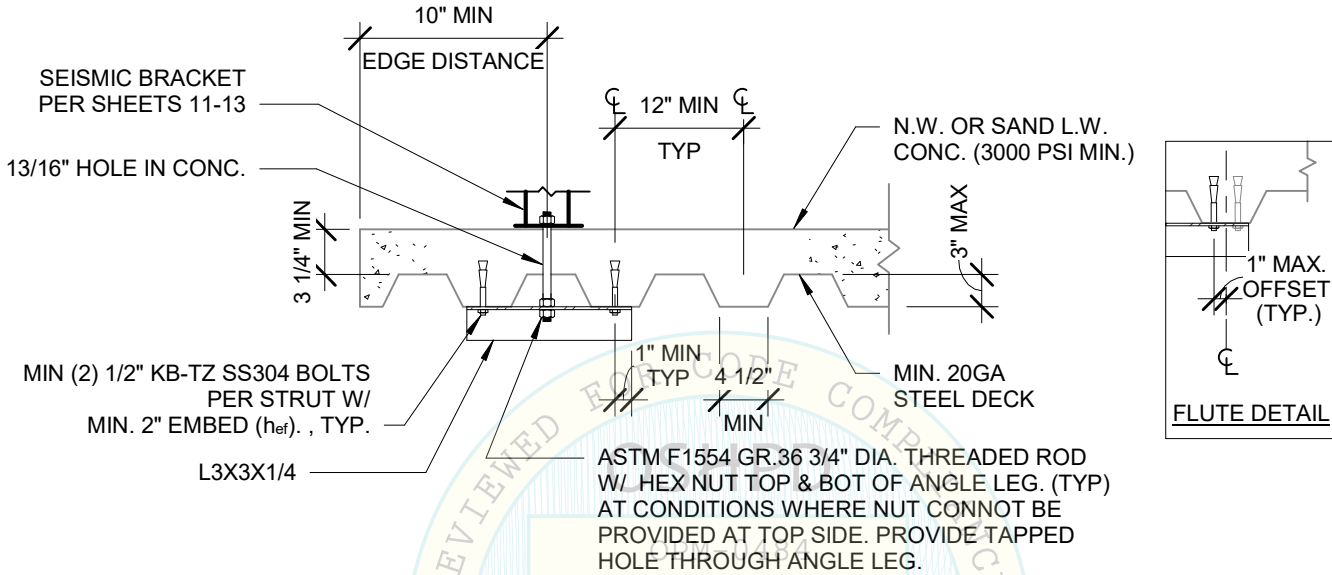

### MIN STEEL DECK REQUIREMENTS AND STRUT DETAIL

DATE: 06/24/2020

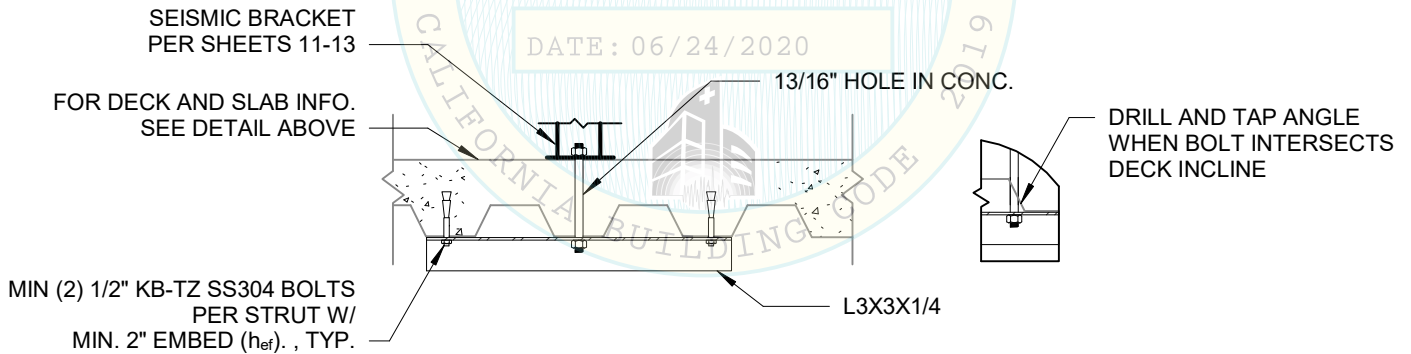

### DETAIL FOR ATTACHMENT BOLT AT THE SIDE OF THE FLUTE OR AT THE BOTTOM FLUTE

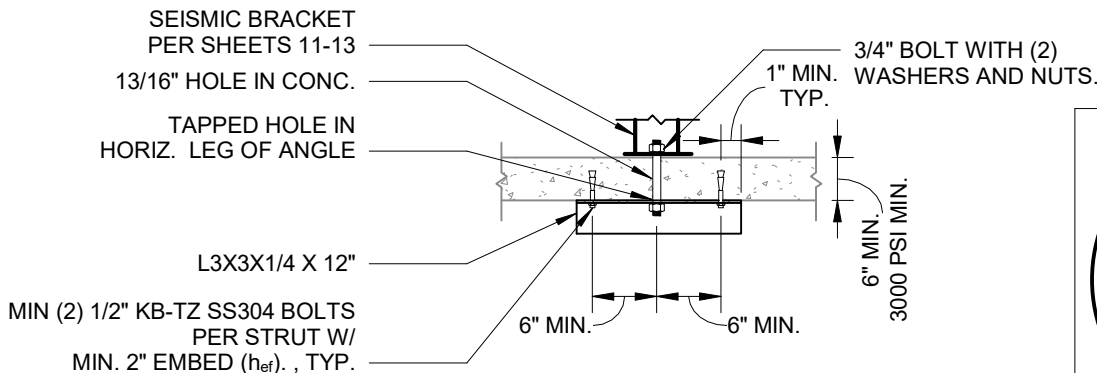

### DETAIL FOR ATTACHMENT BOLT AT SOLID CONCRETE SLABS





ENGINEERING ONE GROUP, INC.  
 Phone: 858.876.8695  
 info@engineeringonegroup.com  
 www.engineeringonegroup.com

# STERIS CORPORATION

## STEAM STERILIZERS 26" X 37.5"

SHEET 11  
 OF 16 SHEETS

Job No. 200001

Date 04/26/2020

Drawn by JY

### SEISMIC TIE DOWN TYPE A

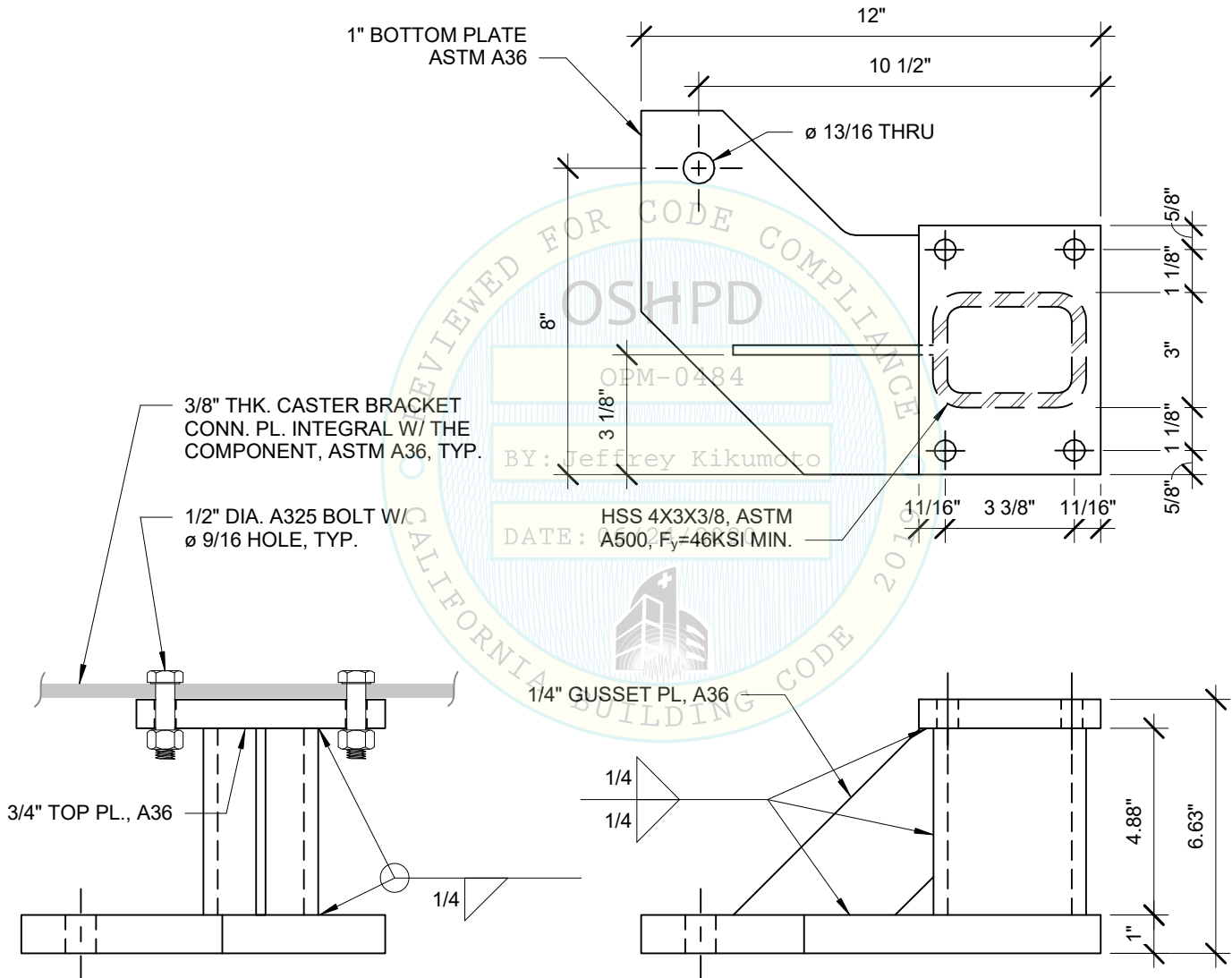

NOTE: ALL SUPPORTS LISTED ON THIS SHEET ARE SUPPLIED BY STERIS.





ENGINEERING ONE GROUP, INC.  
 Phone: 858.876.8695  
 info@engineeringonegroup.com  
 www.engineeringonegroup.com

# STERIS CORPORATION

## STEAM STERILIZERS 26" X 37.5"

SHEET 12  
 OF 16 SHEETS

Job No. 200001

Date 04/26/2020

Drawn by JY

### SEISMIC TIE DOWN TYPE B

TAPPED HOLE PER  
 MFR W/  
 THREADS FOR  
 3/4" DIA. A325 BOLT

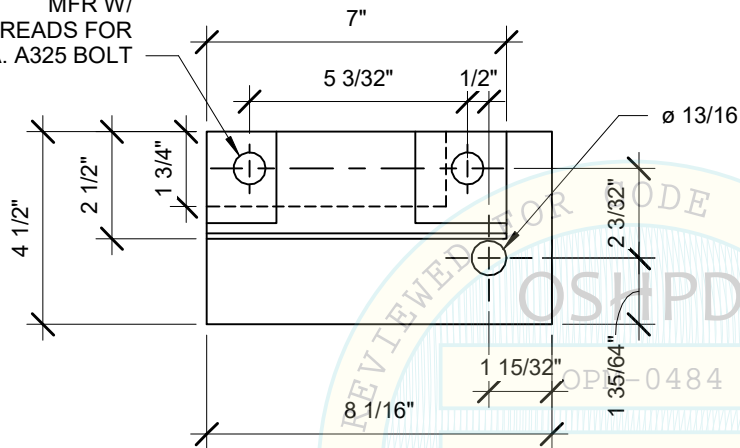

3/4" THK. SHAPED  
 TOP PLATE PER  
 MFR, ASTM A36

3/8" THK. CASTER BRACKET  
 CONN. PL. INTEGRAL W/ THE  
 COMPONENT, ASTM A36, TYP.

3/4" DIA. A325  
 BOLT, TYP.

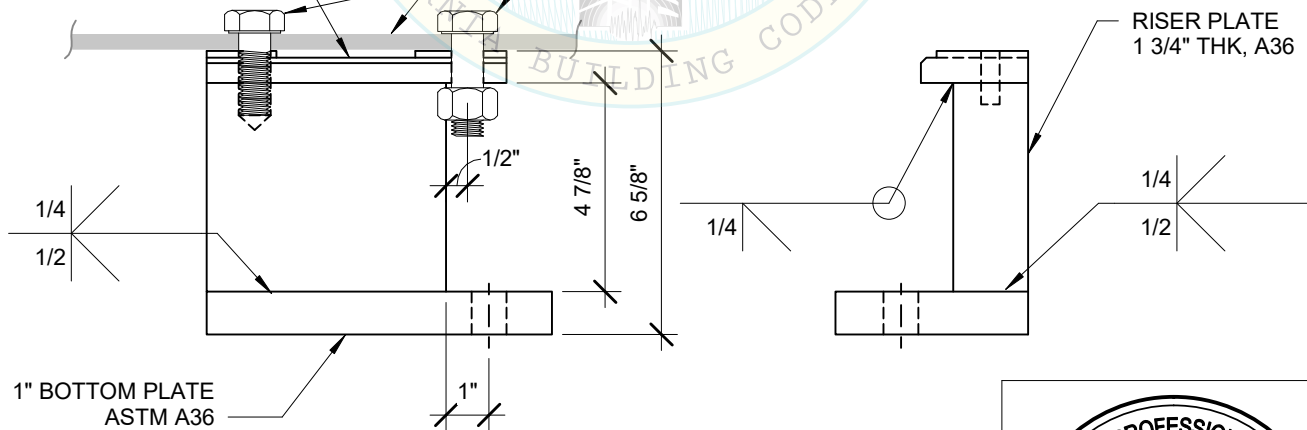

1" BOTTOM PLATE  
 ASTM A36

NOTE: ALL SUPPORTS LISTED ON THIS SHEET IS SUPPLIED BY STERIS.

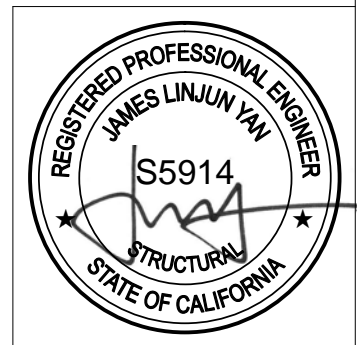

4/26/2020 4:51:52 PM



ENGINEERING ONE GROUP, INC.  
 Phone: 858.876.8695  
 info@engineeringonegroup.com  
 www.engineeringonegroup.com

# STERIS CORPORATION

## STEAM STERILIZERS 26" X 37.5"

SHEET 13  
 OF 16 SHEETS

Job No. 200001

Date 04/26/2020

Drawn by JY

### SEISMIC TIE DOWN TYPE C

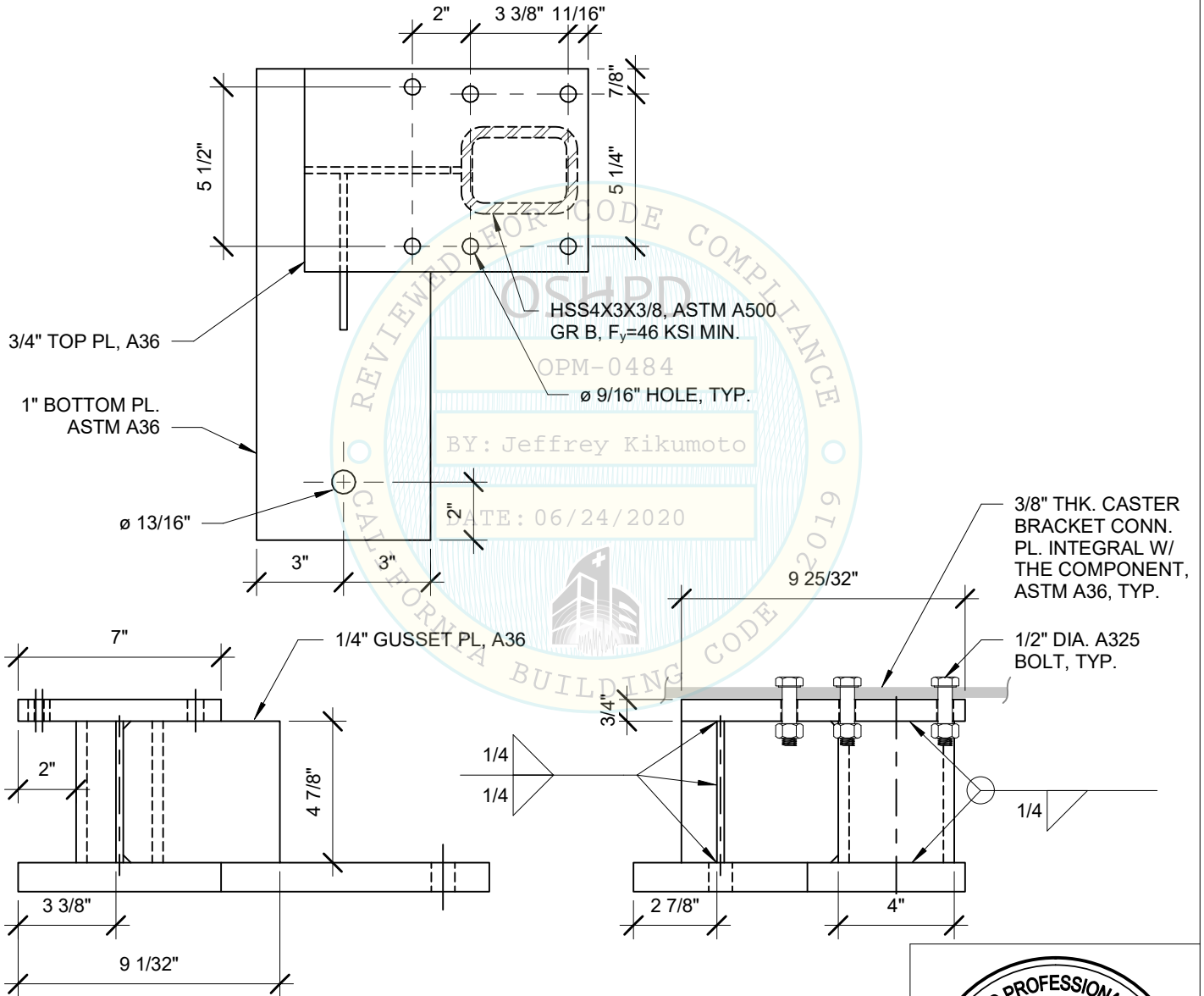

NOTE: ALL SUPPORTS LISTED ON THIS SHEET ARE SUPPLIED BY STERIS.

