



1/1/2024 Seismic Compliance Deadline

Ali Sumer

Supervisor, Seismic Compliance Unit

November 16, 2023

1

SUMMARY

Seismic compliance documents/applications required to be submitted to HCAI/OSHPD by 1/1/2024:

NPC Related

- NPC 3 compliance construction final document *[If GAC building is NPC 2 and located in SDC F site]*
- NPC 4D Evaluation report including Operational Plan *[If GAC building NPC target is not NPC 4]*
- NPC 4 Evaluation report *[If GAC building NPC target is not NPC 4D]*
- NPC 5 Evaluation report including 72hr fuel evaluation and Water Rationing Plan *[All GAC Buildings]*
- Letter of Intent stating GAC services in the building will be removed by 1/1/2030 *[For GAC buildings planned to be removed from GAC services by 1/1/2030]*

AB 1882 related

- Licensed GAC Services Reporting Application *[All buildings under HCAI jurisdiction]*
- Signage Application *[All GAC Buildings]*

2

Definitions, Resources



3

Check out the recent webinars on the website

- NPC and AB 1882 Webinar (3hr long webinar)
- AB 1882 Webinar (detailed step by step application instructions)
- NPC 5 Webinar (detailed user guide instructions, examples)

All slides and video recordings are available on our website:

<https://hcai.ca.gov/construction-finance/resources/building-safety-construction-webinars/>

4

Hospital Functionality

STRUCTURAL

Beams, Columns, Shear Walls, Slabs, Foundations



Structural Performance Category (SPC)

NONSTRUCTURAL

Cladding, Partitions, Ceilings, Equipment, Pipes, Furnishings, Contents, Elevators, Stairs, etc

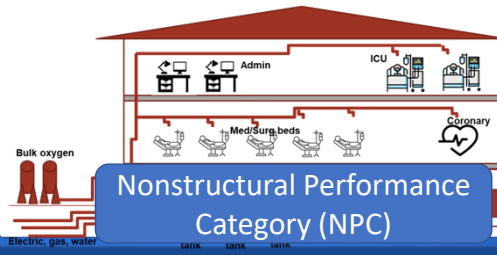

Nonstructural Performance Category (NPC)

STAFF



5

Structural Performance Categories

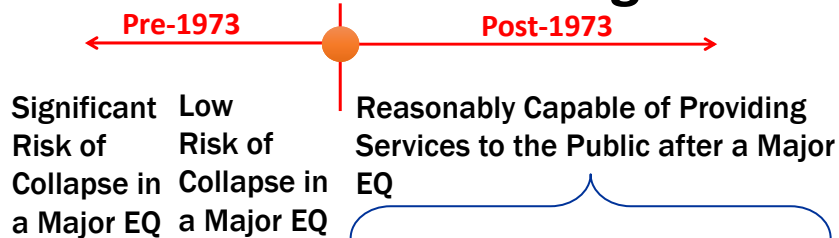

SPC1	SPC2	SPC3	SPC4	SPC5
			SPC4D	

6

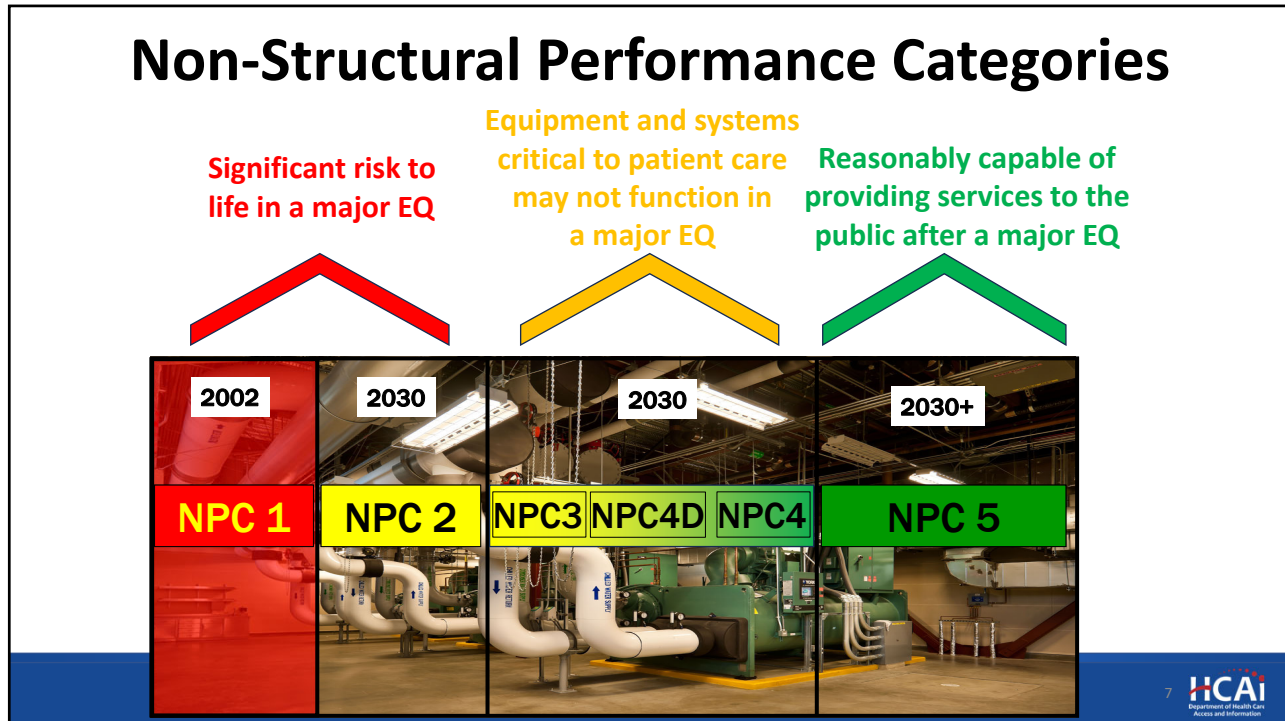

7

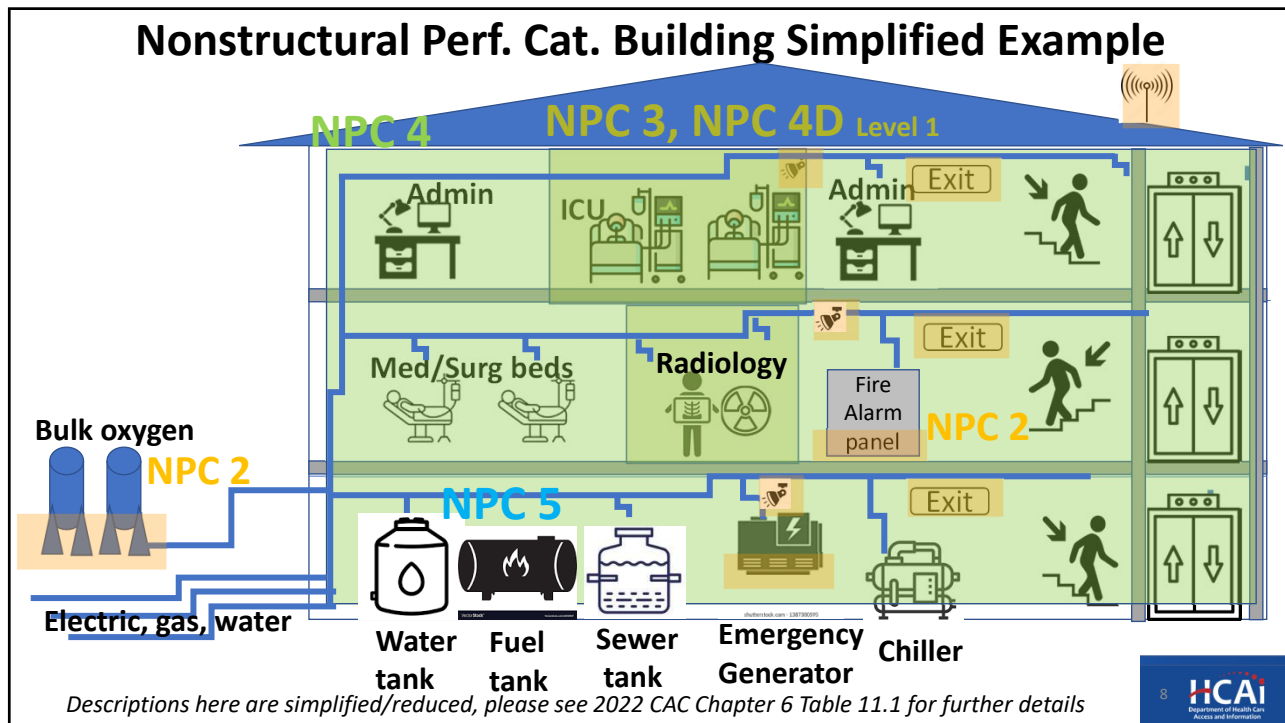

8

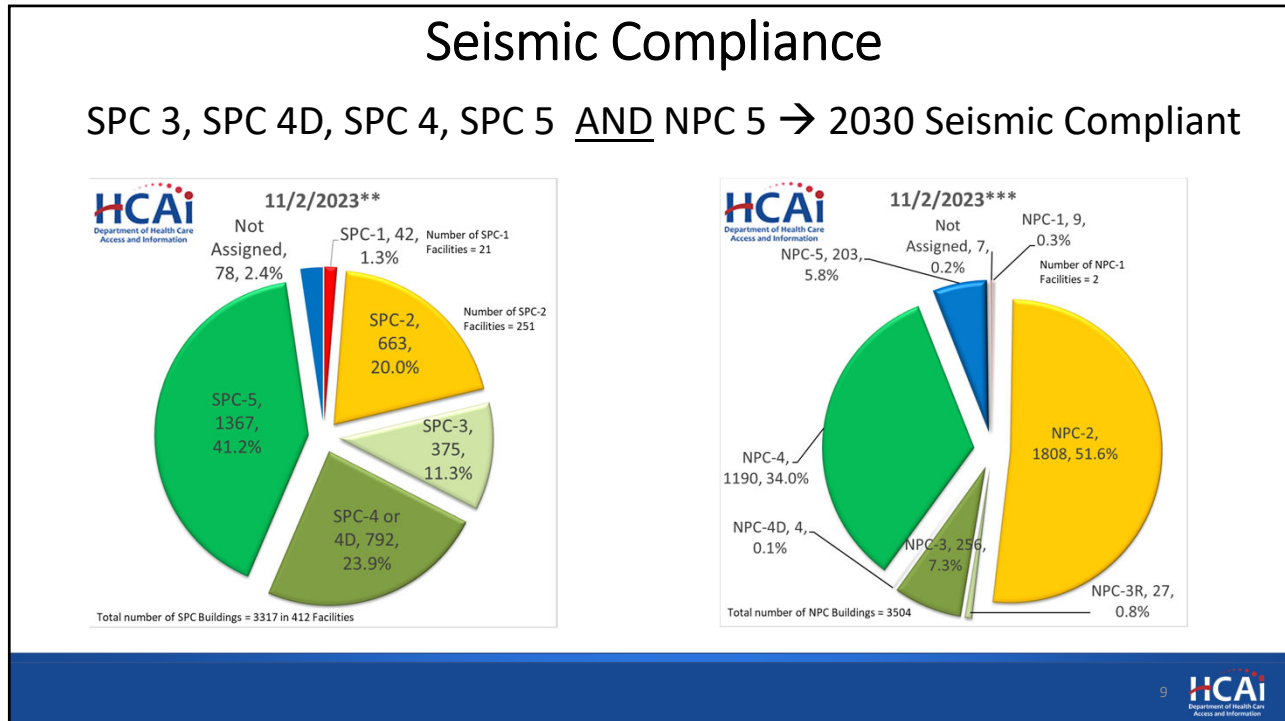

9

Website - Finding Seismic Compliance Info

- Building Safety & Finance
- Loan Repay
- Building Safety & Finance
 - Building & Construction Projects
 - eServices Portal (eSP)
 - Forms, Training, and Resources
 - **Facility Detail**
 - Preapproval Programs
 - Codes and Regulations
 - Seismic Compliance and Safety
 - Hospital Inspection Services
 - Construction Financing

Facility Info | **Building List/Seismic Info** | Building Services | Instrumented Buildings | AB2190 Report | Unauthorized Construction | Building Operational Plan

Show facilities: Facility List Drop-down

(All)
 Do not have AB 2190 Extensions
 Have AB 2190 Extensions

<p>12476 UCSF Medical Center (OSHPD ID: 106381154) 505 Parnassus Avenue San Francisco, CA-94143 County: San Francisco License Type: General Acute Care HCAI Geographic Region: Central Region</p>	
<p>Supervisor: Bhatia (916) 440-8388 Bhatia@hcai.ca.gov</p>	
<p>Regional Compliance Officer: Richard George (916) 628-3996 Richard.George@hcai.ca.gov</p>	
<p>Compliance Officer: Patrick Carroll (916) 995-2073 Patrick.Carroll@hcai.ca.gov</p>	
<p>District Structural Engineer Name: Shane Gross (510) 967-2305 Shane.Gross@hcai.ca.gov</p>	

[Site Plan](#)

Overview → **1-Website** → 2-Project Doc → 3-Outlet Plans → 4-Services → 5-Signage

10

10

Facility Key Plan (site plan)

Facility Detail

Click on the Facility List Drop-down below and scroll to find and select a facility. Or click the drop-down and begin typing a facility name or number to filter the list. Data is updated every 2 weeks.
Note: All 2020 Quarterly Reports are now available.

For available copies of facility site plans, click [Facility Site Plan Download](#).

Facility List Drop-down

10052 Sutter Delta Medical Center
 County: Colusa
 License Type: General Acute Care
 Facility: Sutter Delta Medical Center
 Facility Address: 1515 44C-0423
 Regional Construction Officer: Joe Jensen (916) 222-2047
 Compliance Officer: Bart Tye (916) 228-8742
 District Structural Engineer Name: Bruce Starman (916) 228-8889
 Fire Life Safety Officer Name: John Kelly (916) 228-8742

**Sutter Delta Medical Center
Facility No. 10052** 03/18/16

11

Building List/Seismic Info													Back to Main	
Bldg Num	Bldg Name	Classification & Status	RACs Date	NPC Date	Building Code	Year Built	Stories	Height in Feet	Instrumented	Construction Type	Sprinklered	AB1882 Signage		
BLD-01351	Original Building	OSHPD 1, In Service	1/1/2030	1/1/2030 *	1955 Uniform Building Code (UBC)	1958	1	13	No			Compliant	SPC: 2 NPC: 2 This building does not significantly jeopardize life, but may not be repairable or functional following an earthquake	
BLD-01353	1976 Addition	OSHPD 1, In Service		1/1/2030 *	1973 California Building Code (CBC)	1977	1	Unknown	No			Compliant	SPC: 4 NPC: 2	
BLD-01354	South Addition	OSHPD 1, In Service		1/1/2030 *	1982 California Building Code (CBC)	1994	1	Unknown	No			Compliant	SPC: 4 NPC: 2	
BLD-06957	Skilled Nursing Facility	OSHPD 2, In Service			2019 California Building Code (CBC)			Unknown					SPC: N/A NPC: N/A	

Facility Seismic Design Parameters for New Buildings

Facility Seismic Design Parameters for Existing Buildings

ASCE 7-16 Tsunami Design not required

AB 2190 Quarterly Report

SPC = Structural Performance Category
 NPC = Nonstructural Performance Category
 SPC and NPC are applicable to Hospital Buildings only
 Its 4s and 5s indicate SPC/NPC rating self-reported by the hospital and not verified by CSE/NPC
 Risk Bld = Risk Based SB 90 extension
 Fin Bldg = Financial Hardship based SB 90 extension
 Com Acc = Community Access based SB 90 extension
 GAC = General Acute Care
 RAC = Removal Acute Care Services
 Retrofits = Building will be retrofitted
 Relocate = GAC services will be moved to new buildings
 Replace = GAC services will be moved to existing SPC 2 or higher buildings
 Remove = GAC services will be removed from building
 COOP = Certificate of Occupancy/Certificate of Substantial Compliance
 Construction Final indicates terms of extension have been met.

12

For accessible copies of facility site plans email [Seismic Compliance Unit](#).

Facility Info | Building List/Seismic Info | **Building Services** | Instrumented Buildings | AB2190 Report | Unauthorized Construction | Building Operational Plan

[Back to Main](#)

Applicable Year: 2023

12295 Sharp Coronado Hospital and Healthcare Center

Bldg Num	Bldg Name	Applicable Year	Nursing Med Surg	Surgical	Outpatient PACU	Clinical Lab	Imaging Radiological Diagnostic Imaging	Pharmacy	Diabetic	Administrative	Sterile Processing	General Storage	Morgue	Employee Dressing	Housekeeping/EVS	Laundry Linen	Special Procedures	CU/CCU/ICU	Burn Unit	Neonatal Intensive Care Unit	Pediatric Adolescent Nursing Unit	Psychiatric Nursing	Obstetrics Perinatal Unit	Emergency	Nuclear Medicine	Rehabilitation Therapy	Physical Rehabilitation Nursing Unit	Renal Dialysis	Respiratory	Intermediate Care	Outpatient Services	Skilled Nursing Unit	Central Plant Utility Bldg	Complex Corridor Buildings/Tunnels	Non-GAC Users	
BLD-02091	Main Tower	2023	X	X	X	X	X	X	X	X	X	X	X	X												X		X	X	X						SPC: 2 NPC: 2 This building does not significantly jeopardize life, but may not be repairable or functional following an earthquake.
BLD-02092	ICU Building (Emergency Department Building)	2023	X														X						X						X							SPC: 2 NPC: 2 This building does not significantly jeopardize life, but may not be repairable or functional following an earthquake.
BLD-02093	Ancillary Building	2023				X		X		X	X																				X					SPC: 2 NPC: 2 This building does not significantly jeopardize life, but may not be repairable or functional following an earthquake.
BLD-02627	Prospect Place Canopy	2023																													X					SPC: 5 NPC: 4

13 

13

Facility Info | Building List/Seismic Info | Building Services | Instrumented Buildings | AB2190 Report | Unauthorized Construction | **Building Operational Plan**

12364 Sharp Memorial Hospital Operational Plans

Click to see Operational Plan

Bldg Num	Bldg Name	Classification & Status	
BLD-03755	Corridor 2 - North	OSHDP 1, In Service	SPC: 4 NPC: 4D-L1 Click to see Operational Plan
BLD-03756	Corridor 2 - Middle	OSHDP 1, In Service	SPC: 4 NPC: 4D-L1 Click to see Operational Plan
BLD-03757	Corridor 2 - South	OSHDP 1, In Service	SPC: 4 NPC: 4D-L1 Click to see Operational Plan
BLD-03758	Corridor 2 - Long Term Care	OSHDP 1, In Service	SPC: 4 NPC: 4D-L1 Click to see Operational Plan

14 

14

The screenshot shows the HCAI website interface. On the left is a dark blue navigation menu with the following items: Building Safety & Finance, Loan Repayments, Building Safety & Finance (sub-menu), Building & Construction Projects, eServices Portal (eSP), Forms, Training, and Resources, Facility Detail, Preapproval Programs, Codes and Regulations, **Seismic Compliance and Safety** (highlighted), Hospital Inspection Services, Construction Financing, Distressed Hospital Loan Program, and Hospital Building Safety Board (HBSB). The main content area is titled 'Seismic Compliance and Safety' and features a 'Program Overview' section with a 'Learn More' button. Below this is a grid of nine topic cards: 'Apply for Seismic Compliance Projects' (highlighted with a red arrow), 'Apply for Seismic Compliance Extensions', 'FAQ's', 'Changes to Seismic Safety Law', 'Structural Performance Categories (SPC)', 'Non-Structural Performance Categories (NPC)', 'Emergency Response Operations', 'Contact Us', and 'Additional Resources'. The HCAI logo and page number '15' are in the bottom right corner.

15

This is a detailed view of the 'Apply for Seismic Compliance Projects' card. The card has a red dashed border and contains the following text: 'Apply for Seismic Compliance Projects', 'Learn about the Seismic Compliance Unit (SCU) application process.', a 'LEARN MORE' button, and a link to 'SEISMIC COMPLIANCE FAQ'S'. The card is part of a grid of nine similar cards on the page.

16

Pre OSA, OSA*, OSHPD buildings

- Before 1973 Constructed under local jurisdiction, pre-OSA buildings
[Non-conforming building]
- 1973 – ~1982 OSA permitted buildings (Hxxxx permit)
- ~1982 – 1996 OSHPD permitted (Fire sprinkler limited evaluation required)
(April 30, 1996 project submittal date)
- 1996 – Today OSHPD permitted (SPC 5, NPC 4/5)

* Reviewed and approved by the Department of General Services, Office of Architecture and Construction, Structural Safety Section.

See 2022 California Administrative Code Chapter 6 Section 11.2

17

NPC Deadlines



18

NPC Compliance Timeframe



- For any general acute care hospital be use as a GAC hospital building after January 1, 2030:
 - **By January 1, 2024**, submit to the Office a complete nonstructural evaluation for each building up to NPC-4 / NPC-4D and NPC 5.
 - **By January 1, 2026**, submit to the Office construction documents ready for review by the Office.



19

NPC Compliance Timeframe

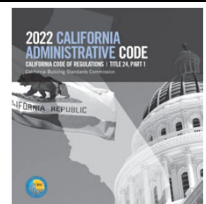

- For any general acute care hospital be use as a GAC hospital building after January 1, 2030:
 - **By January 1, 2028**, obtain a building permit to begin construction. Hospitals not meeting this deadline shall not be issued a building permit except for:
 - Seismic compliance
 - Maintenance
 - Emergency repairs
 See exceptions in 2022 CAC Chapter 6 Section 1.5.2.
 - **By January 1, 2030**, the GAC building shall achieve NPC-5 rating

20

NPC 3 Compliance Deadlines

Seismic Design Category D – January 1, 2030 (high seismic area)

Seismic Design Category F – January 1, 2024 (very high seismic area)

Out of 1808 NPC 2 buildings, there are 52 NPC 2 buildings with Seismic Design Category F deadline (as of 11/16/2023)

(See 2022 CAC Chapter 6 Table 11.1)

What about buildings
that will no longer
provide acute care
services beyond
2030?



Removing GAC Post-2030

NPC permitted to remain at NPC-2 till 1/1/2030 if:

- By **January 1, 2024**, the hospital owner shall submit to the Office an updated [seismic compliance plan](#) for each building to be removed from acute care service beyond January 1, 2030

Submit an application to Seismic Compliance Unit with a Letter of Intent stating GAC services in the building will be removed by 1/1/2030.

By January 1, 2026, a RACS construction project submittal is expected.

- By **January 1, 2028**: Buildings have been removed from general acute care service, or have projects to remove the building from acute care services by 2030.

23

NPC 4D



24

NPC 4D

- See 2022 California Administrative Code Chapter 6, Section 11.2.3
- The building meets the criteria for NPC “3” and for systems listed in Levels 1 to 3, meets the bracing and anchorage requirements of Part 2, Title 24
- There are three levels:
 - NPC 4D Level 1
 - NPC 4D Level 2
 - NPC 4D Level 3
- For Level 1, 2 or 3 : **Operational Plan is required by 1/1/2024.**

25

NPC 4D – Level 1

- Level 1 is the minimum requirement.
(Level 2 and 3 are optional)
- Level 1 is essentially NPC 3 + Operational Plan
- Equipment as listed in the 1995 CBC Table 16A-0, including equipment in the physical plant that service these areas.

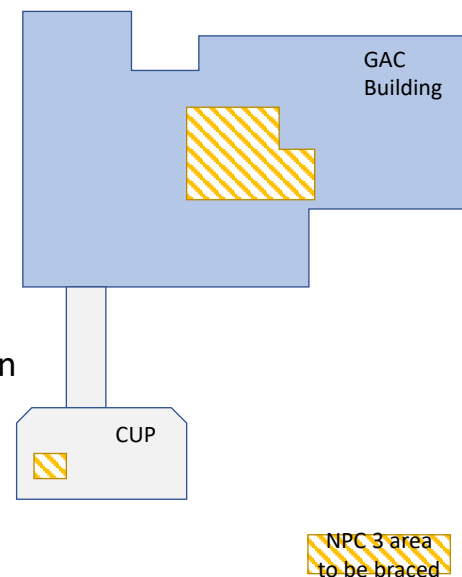

26

NPC 4D – Level 2

- Includes Level 1 and all services and utilities **from the source to Level 1 areas** necessary to accommodate continuation of operations after an event.
- Elevator(s) selected to provide service to patient, surgical, obstetrical, and ground floors during interruption of normal power needed, to meet the structural requirements of Part 2, Title 24.
- Operational Plan

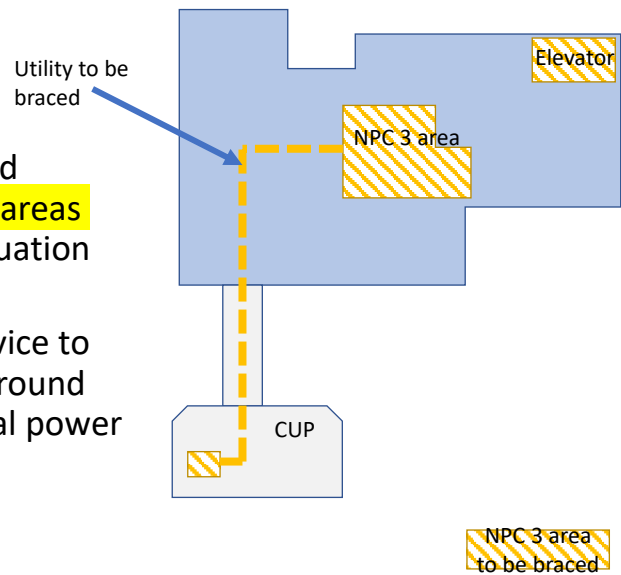

27

NPC 4D – Level 3

- Level 3 includes Level 2, and all systems and equipment are anchored and braced so that additional services, as determined by the hospital in its Operational Plan, are functional and available to the public after a seismic event.

28

NPC 4D Operational Plan

- The facility must prepare an **owner-approved** Operational Plan specifying how it will repair nonstructural damage and bring systems and services back online, or provide them in an **alternative manner** to accommodate continuation of critical care operations.
- This plan may include any other units or departments that hospitals may wish to keep operational for a minimum of 72 hours after a seismic event or other natural or human-made disaster.
- The Operational Plan shall be filed with the Office and shall include an executive summary, a detailed narrative of management of utilities, provisions, sustainability, and alternate means.
- Operational Plan document will be published on HCAI website

NPC 4D Operational Plan

Question: Does the NPC 4D evaluation have to include the operational plan by 1/1/2024? Can we submit it later?

Answer: Operational plan is critical part of NPC 4D evaluation, required by 2022 CAC Chapter 6 Section 11.2.3 item (f) by **1/1/2024**



31

NPC 4

- Submit NPC 4 application to Seismic Compliance Unit by 1/1/2024
- Brace/evaluate all architectural, equipment etc. per CAC Chapter 6 Table 11.1]
- NPC 3 areas - exceptions don't apply.
- If project already has OSHPD project # (closed in compliance), no re-evaluation of the OSHPD project scope components required.
- **No operational plan required**

32

FAQ

Question: We submitted NPC 4 evaluation already. After the 1/1/2024 deadline, can we change it NPC 4D?

Answer: Yes. Please submit an NPC 4D evaluation. The scope of construction project will need to be revised once NPC 4D evaluation is approved (by 1/1/2026 construction document submittal).

Similarly, NPC 4D evaluation can be changed to NPC 4 after the deadline.

33

NPC 5



34

NPC 5 Compliance by 2030

- **An NPC-5-compliant Hospital Facility is capable to support 72 hours of emergency operations during widespread damage caused by a Major EQ.**
- What does being reasonably capable of providing services to the public after a disaster mean?
 - Water storage/water conservation plan
 - Waste water storage
 - Fuel storage for emergency generator(s)
 - Utilities and systems anchored and braced



35

NPC-5 Water Rationing Plan Guide - Update

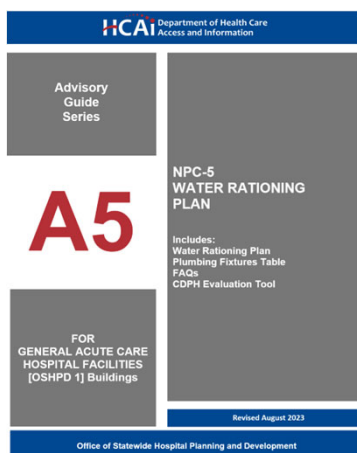

- *Latest update: August 2023.*
 - *NO NEW REQUIREMENTS*
 - *FAQ is added*
 - *CDPH internal checklist is added*
 - *Industrial water for temperature control*
 - *Summary tables improved*
 - *Minor editorial*

36

FAQ

Question: We submitted NPC 5 evaluation already. After the 1/1/2024 deadline, can we reduce the water tank size with further analysis? For example reducing the water tank size from 20,000 gallon to 10,000 gallon?

Answer: Yes. Submit a revised NPC 5 evaluation. The scope of construction project needs to be revised to approved NPC 5 evaluation (by 1/1/2026 construction document submittal).

FAQ

Question: Is NPC 5 submittal facility wide? Or is it building by building?

Answer: NPC 5 is building by building rating, not facility wide. One NPC 5 application for each building is required. We recommend the following process to expedite document submittal and review:

- 1) Submit one facility wide NPC 5 report, clearly listing all GAC building numbers (including non-water buildings such as canopies etc.)
- 2) In the application email, please request to open a NPC 5 project number for each building (if there are 20 buildings, 20 applications will be created for you).
- 3) Same NPC 5 report will be copied under each building application.

The reason for one application for each building: Later in the review, few buildings may get comments, few other may get approved, few may have to wait construction etc.

AB1882



39

What is AB 1882?

AB 1882 seeks to raise the awareness of a general acute care hospital's compliance with the seismic safety regulations or standards outlined in the Alfred E. Alquist Hospital Facilities Seismic Safety Act of 1983 (HFSSA) through:

- 1) Seismic information on HCAI website (Effective 1/1/23)
- 2) Seismic information on project documentation (Effective 1/1/23)
- 3) Updating Emergency Training, Response, and Recovery Plans, Capital Outlay Plans (Effective 7/1/23)
- 4) Annual status updates, reporting services in each building (Deadline 1/1/24, then annual)
- 5) Facility wide signage/notice showing seismic rating (Deadline 1/1/24)

until seismic compliance is achieved

40

AB 1882 Implementation

PIN 75 Hospital Seismic Safety Public Notices and Annual Status Update Reporting:

- Provides the policy for the implementation of AB1882
- Published on HCAI website: [Codes and Regulations – HCAI](#)
- Published 12/12/2022
- Revised 5/30/2023

PIN 75 requirements are in 2022 California Administrative Code [intervening code cycle] (publication date 1/1/2024)

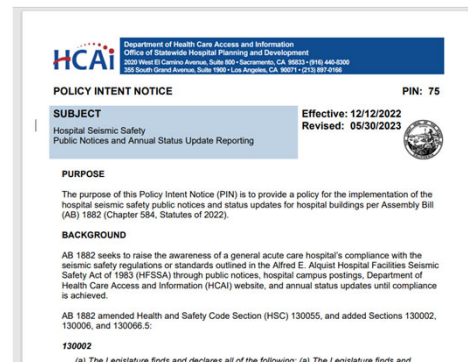

41

AB1882: Annual Status Reporting (Deadline 1/1/2024, then annual)

What is to be reported?

On or before January 1, 2024, and annually thereafter, the owner of an acute care inpatient hospital that includes a general acute care building that is not SPC-3/NPC-5, SPC-4D/NPC-5, SPC-4/NPC-5, or SPC-5/NPC-5 shall provide an annual status update on the **Structural Performance Category ratings** of the buildings and **the services** provided in each hospital building on the hospital campus

42

AB1882: Application Process

AB1882 Service Reporting – Follow the user guide

- One application per facility (no \$250 fee)
- Please follow eSP user guide 25 on the HCAI website
- [Hospital Services Reporting](#)
- Multiple buildings listed on the same application

Project number examples:

GACSERV-2023-00030

GACSERV-2023-00035

GACSERV-2023-00121

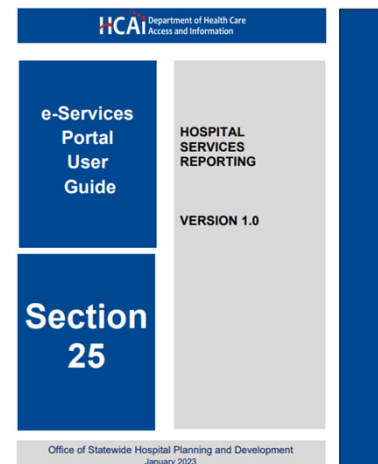

43

AB1882: Annual Status Reporting (By 1/1/2024)

Where else is it required to be reported?

Reporting to be submitted to all of the following entities (submitted by the facility):

- 1) The county board of supervisors in whose jurisdiction the hospital building is located.
- 2) The city council in whose jurisdiction the hospital building is located, if applicable.
- 3) Any labor union representing workers who work in a general acute care building that is not SPC-3/NPC-5, SPC-4D/NPC-5, SPC-4/NPC-5, or SPC-5/NPC-5.
- 4) The board of directors of the special district or joint powers agency that provides fire and emergency medical services in the jurisdiction in which the hospital building is located, if applicable.
- 5) The department. **[This is HCAI]**
- 6) The board of directors of the hospital.
- 7) The local office of emergency services or the equivalent agency.
- 8) The Office of Emergency Services.
- 9) The medical health operational area coordinator.

44

AB1882: Signage (Deadline 1/1/2024)

- Buildings compliant with HSC §130065 means buildings with SPC-3/NPC-5, SPC-4D/NPC-5, SPC-4/NPC-5, or SPC-5/NPC-5 ratings.
- Before January 1, 2024, the owner of an acute care inpatient hospital that includes a general acute care (GAC) building that is not SPC-3/NPC-5, SPC-4D/NPC-5, SPC-4/NPC-5, or SPC-5/NPC-5 shall post a notice in a public space, designated as **any lobby or waiting area**.

AB1882: Signage (Deadline 1/1/24)

- The proposed location and the content of the notice are required to be accepted by the department through an application.
- If there is no lobby/waiting area, an appropriate posting location will be chosen.

This Building's Seismic Performance Rating

Structural Integrity

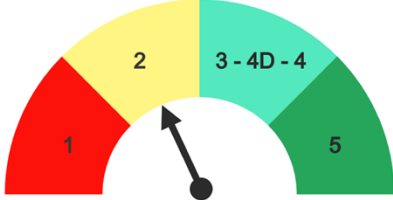

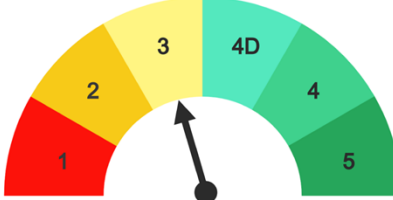

Equipment and Systems
Critical to Patient Care



The State of California has determined that this building does not significantly jeopardize life, but may not be repairable or functional following an earthquake.

More info:





Facility Number:

Building Number: BLD-



47

AB1882: Signage Application Process - STEPS

AB1882 Signage

- One application per building is required (no \$250 fee)
- Please follow eSP user guide 26 on the HCAI website:
[Hospital Signage Reporting User Guide](#)
- Once the documents are reviewed and accepted by HCAI, HCAI field staff will verify the signage on-site
- No permit is generated

Project number examples:
GACSIGN-2023-00019
GACSIGN-2023-00020
GACSIGN-2023-00021

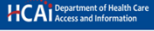

e-Services
Portal
User
Guide

HOSPITAL
SIGNAGE
REPORTING

VERSION 1.0

Section
26

Office of Statewide Hospital Planning and Development
January 2023



48

AB1882: Signage Application Process - STEPS

Floor plan indicating signage locations

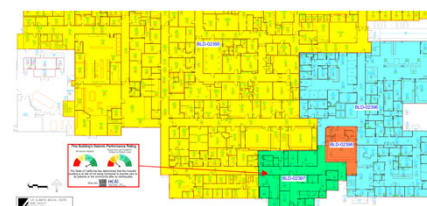
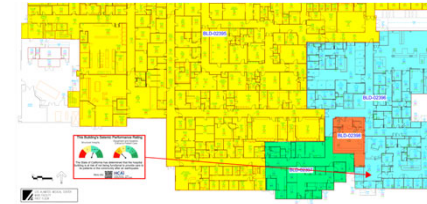
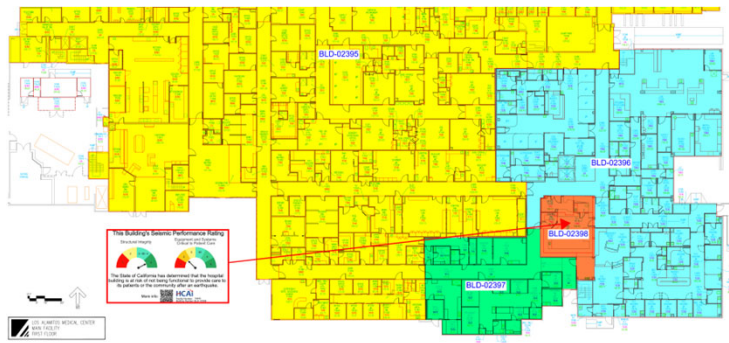

49

49

FAQs - AB1882 Signage

Is only one notice needed for each non-compliant structure?

The law requires posting in any lobby or waiting area generally accessible to patients. The department may agree with a fewer number of posting locations depending on the floor(s) layout and use of space. Please submit an application with proposed posting locations for the department's review and approval.

Can this be done as part of another ongoing project on the site?

No. Please submit a new AB 1882 signage application using eSP.

There are general acute care buildings without lobby or waiting areas, would posting still be required?

If there is no lobby or waiting area, the department will review the location of the posting on a case-by-case basis. AB 1882 posting **is not required for equipment yards, tunnels, canopies, cooling towers, or emergency generator enclosures.**

50

50

FAQs - AB1882 Signage

Are these signs expected to be printed pieces of paper? What about signage to wall connection detail?

There is no required material type for the signage. The signage should be protected from damage and securely adhered or hung on the wall.

Is it sufficient to provide a general location, such as pointing to the approximate area on a floor plan, or does the exact location need to be specified?

Pointing to the approximate area on a floor plan is acceptable. The installed signage is required to be verified and accepted by HCAI field staff.

Will the HCAI regions be reviewing these AB 1882 projects, or will they go through the Seismic Compliance Unit?

Review and approval will be done by the corresponding region or field staff.

SUMMARY

Seismic compliance documents/applications required to be submitted to HCAI/OSHPD by 1/1/2024:

NPC Related

- NPC 3 compliance construction final document *[If GAC building is NPC 2 and located in SDC F site]*
- NPC 4D Evaluation report including Operational Plan *[If GAC building NPC target is not NPC 4]*
- NPC 4 Evaluation report *[If GAC building NPC target is not NPC 4D]*
- NPC 5 Evaluation report including 72hr fuel evaluation and Water Rationing Plan *[All GAC Buildings]*
- Letter of Intent stating GAC services in the building will be removed by 1/1/2030 *[For GAC buildings planned to be removed from GAC services by 1/1/2030]*

AB 1882 related

- Licensed GAC Services Reporting Application *[All buildings under HCAI jurisdiction]*
- Signage Application *[All GAC Buildings]*



Thank You!

Questions?
Please email

SeismicComplianceUnit@hcai.ca.gov